



Document Title
1Gbit (128Mx8bit / 64Mx16bit) NAND Flash Memory

Revision History

Revision No.	History	Draft Date	Remark																											
0.0	1) Initial Draft.	Aug. 2004	Preliminary																											
0.1	1) Correct Fig.10 Sequential out cycle after read 2) Add the text to Fig.1, Table.1, Table.2 - text : IO15 - IO8 (x16 only) 3) Delete '3.2 Page program NOTE 1. - Note : if possible it is better to remove this constrain 4) Change the text (page 10,13, 45) - 2.2 Address Input : 28 Addresses -> 27 Addresses - 3.7 Reset : Fig.29 -> Fig.30 - 5.1 Automatic page read after power up : Fig.30 -> Fig.29 5) Add 5.3 Addressing for program operation & Fig.34	Sep. 2004	Preliminary																											
0.2	1) Change TSOP, WSOP, FBGA package dimension & figures. - Change TSOP, WSOP, FBGA package mechanical data - Change FBGA thickness (1.2 -> 1.0 mm) 2) Correct TSOP, WSOP Pin configurations. - 38th NC pin has been changed Lockpre(figure 3,4) 3) Edit figure 15,19 & table 4 4) Add Bad Block Management 5) Change Device Identifier 3rd Byte - 3rd Byte ID is changed. (reserved -> don't care) - 3rd Byte ID table is deleted.	Oct. 2004	Preliminary																											
0.3	1) Add Errata <table border="1" data-bbox="327 1317 1098 1444"> <thead> <tr> <th></th> <th>tCLS</th> <th>tCLH</th> <th>tWP</th> <th>tALS</th> <th>tALH</th> <th>tDS</th> <th>tWC</th> <th>tR</th> </tr> </thead> <tbody> <tr> <td>Specification</td> <td>0</td> <td>10</td> <td>25</td> <td>0</td> <td>10</td> <td>20</td> <td>50</td> <td>25</td> </tr> <tr> <td>Relaxed value</td> <td>5</td> <td>15</td> <td>40</td> <td>5</td> <td>15</td> <td>25</td> <td>60</td> <td>27</td> </tr> </tbody> </table> 2) LOCKPRE is changed to PRE. - Texts, Table, Figures are changed. 3) Add Note.4 (table.14) 4) Block Lock Mechanism is deleted. - Texts, Table, figures are deleted. 5) Add Application Note(Power-On/Off Sequence & Auto Sleep mode.) - Texts & Figures are added. 6) Edit the figures. (#10~25)		tCLS	tCLH	tWP	tALS	tALH	tDS	tWC	tR	Specification	0	10	25	0	10	20	50	25	Relaxed value	5	15	40	5	15	25	60	27	Nov.29 2004	Preliminary
	tCLS	tCLH	tWP	tALS	tALH	tDS	tWC	tR																						
Specification	0	10	25	0	10	20	50	25																						
Relaxed value	5	15	40	5	15	25	60	27																						
0.4	1) Change AC characteristics(tREH) before: 20ns -> after: 30ns 2) Edit Note.1 (page. 21) 3) Edit the Application note 1,2 4) Edit The Address cycle map (x8, x16)	Jan.19 2005	Preliminary																											



Revision History

- Continued -

Revision No.	History	Draft Date	Remark																								
0.5	1) Correct AC characteristics(tREH) before: 30ns-> after: 20ns 2) Add Errata <table border="1" style="margin-left: 20px;"> <thead> <tr> <th></th> <th>Case</th> <th>tRC</th> <th>tRP</th> <th>tREH</th> <th>tREA</th> </tr> </thead> <tbody> <tr> <td>Specification</td> <td>Read(all)</td> <td>50</td> <td>20</td> <td>20</td> <td>30</td> </tr> <tr> <td>Relaxed value</td> <td>Except for ID Read</td> <td>50</td> <td>20</td> <td>20</td> <td>30</td> </tr> <tr> <td></td> <td>ID Read</td> <td>60</td> <td>25</td> <td>30</td> <td>30</td> </tr> </tbody> </table>		Case	tRC	tRP	tREH	tREA	Specification	Read(all)	50	20	20	30	Relaxed value	Except for ID Read	50	20	20	30		ID Read	60	25	30	30	Jan. 25. 2005	Preliminary
	Case	tRC	tRP	tREH	tREA																						
Specification	Read(all)	50	20	20	30																						
Relaxed value	Except for ID Read	50	20	20	30																						
	ID Read	60	25	30	30																						
0.6	1) Change AC characteristics <table border="1" style="margin-left: 20px;"> <thead> <tr> <th></th> <th>tDH</th> </tr> </thead> <tbody> <tr> <td>Before</td> <td>10</td> </tr> <tr> <td>After</td> <td>15</td> </tr> </tbody> </table> 2) Add tADL parameter - tADL=100ns 3) Correct table.9		tDH	Before	10	After	15	Mar. 09. 2005	Preliminary																		
	tDH																										
Before	10																										
After	15																										
0.7	1) Correct AC Timing Characteristics Table - Errata value is edited. - tADL(max) is changed to tADL(min). 2) Change Errata - tREA is deleted from the errata <table border="1" style="margin-left: 20px;"> <thead> <tr> <th></th> <th>Case</th> <th>tRC</th> <th>tRP</th> <th>tREH</th> </tr> </thead> <tbody> <tr> <td rowspan="2">Before</td> <td>Except for ID Read</td> <td>50</td> <td>20</td> <td>20</td> </tr> <tr> <td>ID Read</td> <td>60</td> <td>25</td> <td>30</td> </tr> <tr> <td>After</td> <td>Read (all)</td> <td>60</td> <td>25</td> <td>30</td> </tr> </tbody> </table> 3) Edit pin Description table 4) Delete Multiple Die & Stacked Devices Access - Texts & tables are deleted. 5) Edit Data Protection texts 6) Add Read ID table 7) Add tOH parameter - tOH=15ns(min.) 8) Add Marking Information 9) Correct application note.2 - tCS(2us) is changed to 100ns.		Case	tRC	tRP	tREH	Before	Except for ID Read	50	20	20	ID Read	60	25	30	After	Read (all)	60	25	30	Apr. 06. 2005	Preliminary					
	Case	tRC	tRP	tREH																							
Before	Except for ID Read	50	20	20																							
	ID Read	60	25	30																							
After	Read (all)	60	25	30																							



Revision History

- Continued -

Revision No.	History	Draft Date	Remark																								
0.8	1) Correct the test Conditions (DC Characteristics table) <table border="1" style="margin-left: 20px;"> <thead> <tr> <th></th> <th>Test Conditions (ICC1)</th> <th>Test Conditions (ILI, ILo)</th> </tr> </thead> <tbody> <tr> <td>Before</td> <td>t_{RC}=50ns, CE#=V_{IL}, I_{OUT}=0mA</td> <td>V_{IN}=V_{OUT}=0 to 3.6V</td> </tr> <tr> <td>After</td> <td>t_{RC}(1.8V=60ns, 3.3V=50ns) CE#=V_{IL}, I_{OUT}=0mA</td> <td>V_{IN}=V_{OUT}=0 to V_{CC} (max)</td> </tr> </tbody> </table> 2) Change AC Conditions table 3) Add t _{WW} parameter (t _{WW} = 100ns, min) - Texts & Figures are added. - t _{WW} is added in AC timing characteristics table. 4) Edit System Interface Using \overline{CE} don't care Figures. 5) Correct Address Cycle Map.		Test Conditions (ICC1)	Test Conditions (ILI, ILo)	Before	t _{RC} =50ns, CE#=V _{IL} , I _{OUT} =0mA	V _{IN} =V _{OUT} =0 to 3.6V	After	t _{RC} (1.8V=60ns, 3.3V=50ns) CE#=V _{IL} , I _{OUT} =0mA	V _{IN} =V _{OUT} =0 to V _{CC} (max)	Aug. 03. 2005	Preliminary															
	Test Conditions (ICC1)	Test Conditions (ILI, ILo)																									
Before	t _{RC} =50ns, CE#=V _{IL} , I _{OUT} =0mA	V _{IN} =V _{OUT} =0 to 3.6V																									
After	t _{RC} (1.8V=60ns, 3.3V=50ns) CE#=V _{IL} , I _{OUT} =0mA	V _{IN} =V _{OUT} =0 to V _{CC} (max)																									
0.9	1) Change 1Gb Package Type. - FBGA package is deleted. - USOP package is added. - Figure & dimension are changed. 2) Correct PKG dimension (TSOP, USOP PKG) <table border="1" style="margin-left: 20px;"> <thead> <tr> <th></th> <th>CP</th> </tr> </thead> <tbody> <tr> <td>Before</td> <td>0.050</td> </tr> <tr> <td>After</td> <td>0.100</td> </tr> </tbody> </table> 3) Delete Errata 4) Change AC Characteristics <table border="1" style="margin-left: 20px;"> <thead> <tr> <th></th> <th>t_{RC}</th> <th>t_{RP}</th> <th>t_{REH}</th> </tr> </thead> <tbody> <tr> <td rowspan="2">Before</td> <td>60</td> <td>25</td> <td>30</td> </tr> <tr> <td>60</td> <td>40</td> <td>30</td> </tr> <tr> <td rowspan="2">After</td> <td>50</td> <td>25</td> <td>20</td> </tr> <tr> <td>50</td> <td>25</td> <td>20</td> </tr> </tbody> </table>		CP	Before	0.050	After	0.100		t _{RC}	t _{RP}	t _{REH}	Before	60	25	30	60	40	30	After	50	25	20	50	25	20	Oct. 11. 2005	Preliminary
	CP																										
Before	0.050																										
After	0.100																										
	t _{RC}	t _{RP}	t _{REH}																								
Before	60	25	30																								
	60	40	30																								
After	50	25	20																								
	50	25	20																								
1.0	1) Change AC Characteristics (ID Read) <table border="1" style="margin-left: 20px;"> <thead> <tr> <th></th> <th>t_{RP} (1.8v)</th> <th>t_{RP} (3.3v)</th> </tr> </thead> <tbody> <tr> <td>Before</td> <td>40</td> <td>25</td> </tr> <tr> <td>After</td> <td>25</td> <td>25</td> </tr> </tbody> </table>		t _{RP} (1.8v)	t _{RP} (3.3v)	Before	40	25	After	25	25	Oct. 12. 2005																
	t _{RP} (1.8v)	t _{RP} (3.3v)																									
Before	40	25																									
After	25	25																									
1.1	1) Correct USOP figure.	Nov. 07. 2005																									



FEATURES SUMMARY

HIGH DENSITY NAND FLASH MEMORIES

- Cost effective solutions for mass storage applications

NAND INTERFACE

- x8 or x16 bus width.
- Multiplexed Address/ Data
- Pinout compatibility for all densities

SUPPLY VOLTAGE

- 3.3V device: VCC = 2.7 to 3.6V : HY27UFXX1G2M
- 1.8V device: VCC = 1.7 to 1.95V : HY27SFXX1G2M

Memory Cell Array

- = (2K+ 64) Bytes x 64 Pages x 1,024 Blocks
- = (1K+32) Words x 64 pages x 1,024 Blocks

PAGE SIZE

- x8 device : (2K + 64 spare) Bytes
: HY27(U/S)F081G2M
- x16 device: (1K + 32 spare) Words
: HY27(U/S)F161G2M

BLOCK SIZE

- x8 device: (128K + 4K spare) Bytes
- x16 device: (64K + 2K spare) Words

PAGE READ / PROGRAM

- Random access: 27us⁽¹⁾ (max.)
- Sequential access: 60ns⁽¹⁾ (min.)
- Page program time: 300us (typ.)

COPY BACK PROGRAM MODE

- Fast page copy without external buffering

CACHE PROGRAM MODE

- Internal Cache Register to improve the program throughput

FAST BLOCK ERASE

- Block erase time: 2ms (Typ.)

STATUS REGISTER

ELECTRONIC SIGNATURE

- Manufacturer Code
- Device Code

CHIP ENABLE DON'T CARE OPTION

- Simple interface with microcontroller

AUTOMATIC PAGE 0 READ AT POWER-UP OPTION

- Boot from NAND support
- Automatic Memory Download

SERIAL NUMBER OPTION

HARDWARE DATA PROTECTION

- Program/Erase locked during Power transitions

DATA INTEGRITY

- 100,000 Program/Erase cycles
- 10 years Data Retention

PACKAGE

- HY27(U/S)F(08/16)1G2M-T(P)
: 48-Pin TSOP1 (12 x 20 x 1.2 mm)
- HY27(U/S)F(08/16)1G2M-T (Lead)
- HY27(U/S)F(08/16)1G2M-TP (Lead Free)
- HY27(U/S)F(08/16)1G1M-S(P)
: 48-Pin USOP1 (12 x 17 x 0.65 mm)
- HY27(U/S)F(08/16)1G1M-S (Lead)
- HY27(U/S)F(08/16)1G1M-SP (Lead Free)



HY27UF(08/16)1G2M Series
HY27SF(08/16)1G2M Series
1Gbit (128Mx8bit / 64Mx16bit) NAND Flash

1. SUMMARY DESCRIPTION

The HYNIX HY27(U/S)F(08/16)1G2M series is a 128Mx8bit with spare 4Mx8 bit capacity. The device is offered in 1.8V Vcc Power Supply and in 3.3V Vcc Power Supply.

Its NAND cell provides the most cost-effective solution for the solid state mass storage market.

The memory is divided into blocks that can be erased independently so it is possible to preserve valid data while old data is erased.

The device contains 1024 blocks, composed by 64 pages consisting in two NAND structures of 32 series connected Flash cells.

A program operation allows to write the 2112-byte page in typical 300us and an erase operation can be performed in typical 2ms on a 128K-byte(X8 device) block.

Data in the page mode can be read out at 50ns cycle time per word. The I/O pins serve as the ports for address and data input/output as well as command input. This interface allows a reduced pin count and easy migration towards different densities, without any rearrangement of footprint.

Commands, Data and Addresses are synchronously introduced using CE#, WE#, ALE and CLE input pin.

The on-chip Program/Erase Controller automates all program and erase functions including pulse repetition, where required, and internal verification and margining of data.

The modifying can be locked using the WP# input pin.

The output pin RB# (open drain buffer) signals the status of the device during each operation. In a system with multiple memories the RB# pins can be connected all together to provide a global status signal.

Even the write-intensive systems can take advantage of the HY27(U/S)F(08/16)1G2M extended reliability of 100K program/erase cycles by providing ECC (Error Correcting Code) with real time mapping-out algorithm.

Optionally the chip could be offered with the CE# don't care function. This option allows the direct download of the code from the NAND Flash memory device by a microcontroller, since the CE# transitions do not stop the read operation.

The copy back function allows the optimization of defective blocks management: when a page program operation fails the data can be directly programmed in another page inside the same array section without the time consuming serial data insertion phase.

The cache program feature allows the data insertion in the cache register while the data register is copied into the flash array. This pipelined program operation improves the program throughput when long files are written inside the memory.

A cache read feature is also implemented. This feature allows to dramatically improve the read throughput when consecutive pages have to be streamed out.

This device includes also extra features like OTP/Unique ID area, Automatic Read at Power Up, Read ID2 extension.

The HYNIX HY27(U/S)F(08/16)1G2M series is available in 48 - TSOP1 12 x 20 mm , 48 - USOP1 12 x 17 mm.

1.1 Product List

PART NUMBER	ORIZATION	VCC RANGE	PACKAGE
HY27SF081G2M	x8	1.70 - 1.95 Volt	48TSOP1 / 48USOP1
HY27SF161G2M	x16		
HY27UF081G2M	x8	2.7V - 3.6 Volt	
HY27UF161G2M	x16		

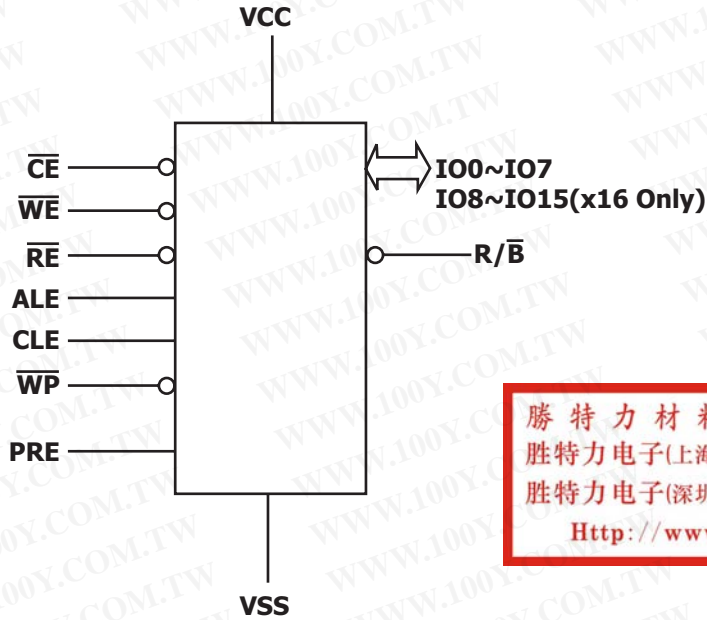

勝特力材料 886-3-5753170
 勝特力电子(上海) 86-21-54151736
 勝特力电子(深圳) 86-755-83298787
[Http://www.100y.com.tw](http://www.100y.com.tw)

Figure1: Logic Diagram

IO15 - IO8	Data Input / Outputs (x16 only)
IO7 - IO0	Data Input / Outputs
CLE	Command latch enable
ALE	Address latch enable
CE#	Chip Enable
RE#	Read Enable
WE#	Write Enable
WP#	Write Protect
RB#	Ready / Busy
Vcc	Power Supply
Vss	Ground
NC	No Connection
PRE	Power-On Read Enable

Table 1: Signal Names

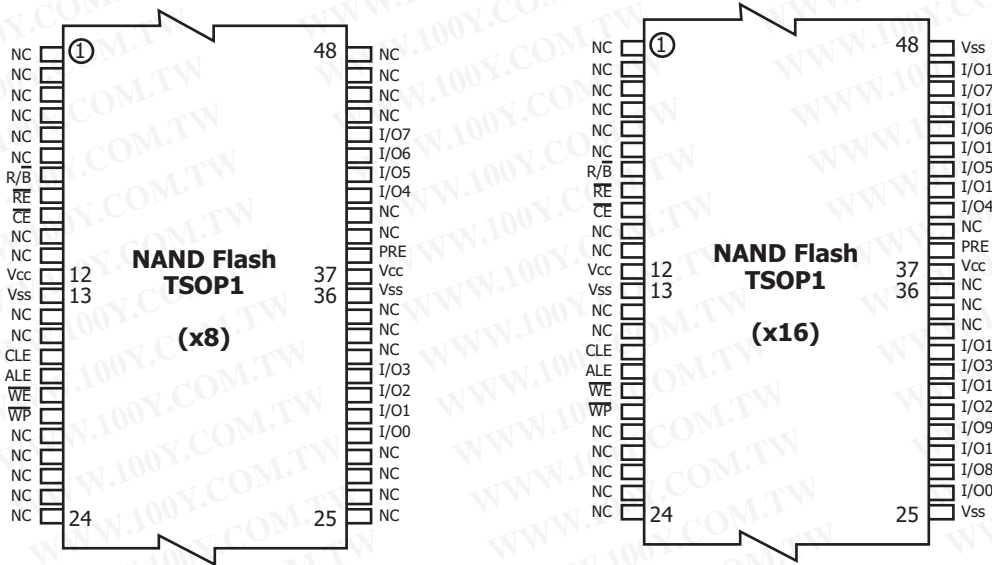

Figure 2. 48TSOP1 Contactions, x8 and x16 Device

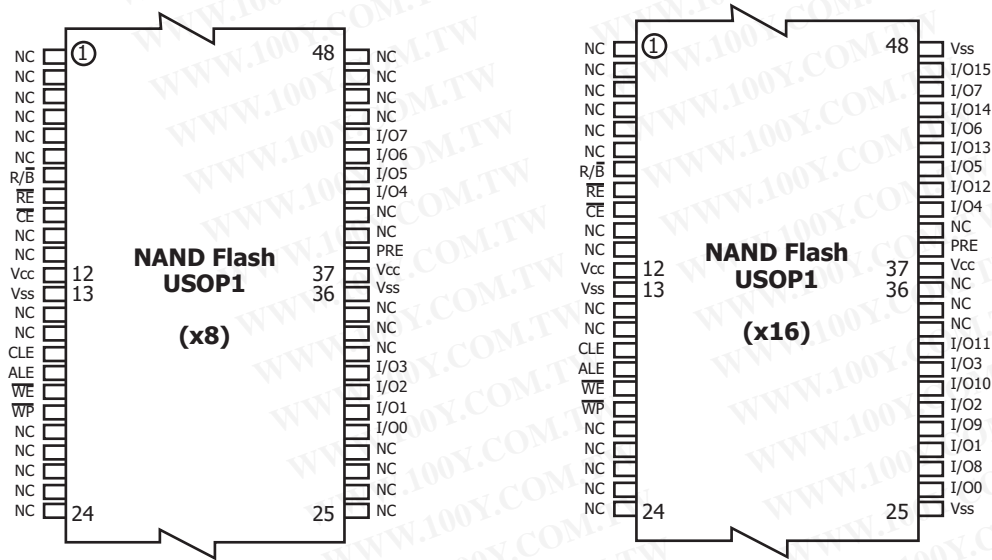

Figure 3. 48USOP1 Contactions, x8 and x16 Device

1.2 PIN DESCRIPTION

Pin Name	Description
I00-I07 I08-I015(1)	DATA INPUTS/OUTPUTS The IO pins allow to input command, address and data and to output data during read / program operations. The inputs are latched on the rising edge of Write Enable (WE#). The I/O buffer float to High-Z when the device is deselected or the outputs are disabled.
CLE	COMMAND LATCH ENABLE This input activates the latching of the IO inputs inside the Command Register on the Rising edge of Write Enable (WE#).
ALE	ADDRESS LATCH ENABLE This input activates the latching of the IO inputs inside the Address Register on the Rising edge of Write Enable (WE#).
CE#	CHIP ENABLE This input controls the selection of the device. When the device is busy CE# low does not deselect the memory.
WE#	WRITE ENABLE This input acts as clock to latch Command, Address and Data. The IO inputs are latched on the rise edge of WE#.
RE#	READ ENABLE The RE# input is the serial data-out control, and when active drives the data onto the I/O bus. Data is valid tREA after the falling edge of RE# which also increments the internal column address counter by one.
WP#	WRITE PROTECT The WP# pin, when Low, provides an Hardware protection against undesired modify (program / erase) operations.
RB#	READY BUSY The Ready/Busy output is an Open Drain pin that signals the state of the memory.
VCC	SUPPLY VOLTAGE The VCC supplies the power for all the operations (Read, Write, Erase).
VSS	GROUND
NC	NO CONNECTION
PRE	To Enable Power On Auto Read. When PRE is a logic high, Power on Auto Read mode is enabled, and when PRE is a logic low, Power Auto Read mode is disabled. Power On Auto Read mode is available only on 3.3V device. Not using POWER-ON AUTO-READ, connect it Vss or leave it N.C.

Table 2: Pin Description

NOTE:

1. For x16 version only
2. A 0.1uF capacitor should be connected between the VCC Supply Voltage pin and the VSS Ground pin to decouple the current surges from the power supply. The PCB track widths must be sufficient to carry the currents required during program and erase operations.



HY27UF(08/16)1G2M Series
HY27SF(08/16)1G2M Series
1Gbit (128Mx8bit / 64Mx16bit) NAND Flash

	IO0	IO1	IO2	IO3	IO4	IO5	IO6	IO7
1st Cycle	A0	A1	A2	A3	A4	A5	A6	A7
2nd Cycle	A8	A9	A10	A11	L ⁽¹⁾	L ⁽¹⁾	L ⁽¹⁾	L ⁽¹⁾
3rd Cycle	A12	A13	A14	A15	A16	A17	A18	A19
4th Cycle	A20	A21	A22	A23	A24	A25	A26	A27

Table 3: Address Cycle Map(x8)

NOTE:

1. L must be set to Low.

	IO0	IO1	IO2	IO3	IO4	IO5	IO6	IO7	IO8-IO15
1st Cycle	A0	A1	A2	A3	A4	A5	A6	A7	L ⁽¹⁾
2nd Cycle	A8	A9	A10	L ⁽¹⁾	L ⁽¹⁾	L ⁽¹⁾	L ⁽¹⁾	L ⁽¹⁾	L ⁽¹⁾
3rd Cycle	A11	A12	A13	A14	A15	A16	A17	A18	L ⁽¹⁾
4th Cycle	A19	A20	A21	A22	A23	A24	A25	A26	L ⁽¹⁾

Table 4: Address Cycle Map(x16)

NOTE:

1. L must be set to Low.

FUNCTION	1st CYCLE	2nd CYCLE	3rd CYCLE	Acceptable command during busy
READ 1	00h	30h	-	
READ FOR COPY-BACK	00h	35h	-	
READ ID	90h	-	-	
RESET	FFh	-	-	Yes
PAGE PROGRAM (start)	80h	10h	-	
COPY BACK PGM (start)	85h	10h	-	
CACHE PROGRAM	80h	15h	-	
BLOCK ERASE	60h	D0h	-	
READ STATUS REGISTER	70h	-	-	Yes
RANDOM DATA INPUT	85h	-	-	
RANDOM DATA OUTPUT	05h	E0h	-	
CACHE READ START	00h	31h	-	
CACHE READ EXIT	34h	-	-	

Table 5: Command Set



CLE	ALE	CE#	WE#	RE#	WP#	MODE	
H	L	L	Rising	H	X	Read Mode	Command Input
L	H	L	Rising	H	X		Address Input(4 cycles)
H	L	L	Rising	H	H	Write Mode	Command Input
L	H	L	Rising	H	H		Address Input(4 cycles)
L	L	L	Rising	H	H	Data Input	
L	L	L ⁽¹⁾	H	Falling	X	Sequential Read and Data Output	
L	L	L	H	H	X	During Read (Busy)	
X	X	X	X	X	H	During Program (Busy)	
X	X	X	X	X	H	During Erase (Busy)	
X	X	X	X	X	L	Write Protect	
X	X	H	X	X	0V/Vcc	Stand By	

Table 6: Mode Selection

NOTE:

1. With the CE# don't care option CE# high during latency time does not stop the read operation

2. BUS OPERATION

There are six standard bus operations that control the device. These are Command Input, Address Input, Data Input, Data Output, Write Protect, and Standby.

Typically glitches less than 5 ns on Chip Enable, Write Enable and Read Enable are ignored by the memory and do not affect bus operations.

2.1 Command Input.

Command Input bus operation is used to give a command to the memory device. Command are accepted with Chip Enable low, Command Latch Enable High, Address Latch Enable low and Read Enable High and latched on the rising edge of Write Enable. Moreover for commands that starts a modifying operation (write/erase) the Write Protect pin must be high. See figure 5 and table 13 for details of the timings requirements. Command codes are always applied on IO7:0, disregarding the bus configuration (X8/X16).

2.2 Address Input.

Address Input bus operation allows the insertion of the memory address. To insert the 27 addresses(x8 device) needed to access the 1Gbit 4 clock cycles are needed. Addresses are accepted with Chip Enable low, Address Latch Enable High, Command Latch Enable low and Read Enable high and latched on the rising edge of Write Enable. Moreover for commands that starts a modify operation (write/erase) the Write Protect pin must be high. See figure 6 and table 13 for details of the timings requirements. Addresses are always applied on IO7:0, disregarding the bus configuration (X8/X16).

2.3 Data Input.

Data Input bus operation allows to feed to the device the data to be programmed. The data insertion is serially and timed by the Write Enable cycles. Data are accepted only with Chip Enable low, Address Latch Enable low, Command Latch Enable low, Read Enable High, and Write Protect High and latched on the rising edge of Write Enable. See figure 7 and table 13 for details of the timings requirements.

2.4 Data Output.

Data Output bus operation allows to read data from the memory array and to check the status register content, the lock status and the ID data. Data can be serially shifted out toggling the Read Enable pin with Chip Enable low, Write Enable High, Address Latch Enable low, and Command Latch Enable low. See figures 8,10,11 and table 13 for details of the timings requirements.

2.5 Write Protect.

Hardware Write Protection is activated when the Write Protect pin is low. In this condition modify operation do not start and the content of the memory is not altered. Write Protect pin is not latched by Write Enable to ensure the protection even during the power up.

2.6 Standby.

In Standby mode the device is deselected, outputs are disabled and Power Consumption is reduced.



勝特力材料 886-3-5753170
勝特力电子(上海) 86-21-54151736
勝特力电子(深圳) 86-755-83298787
Http://www.100y.com.tw

HY27UF(08/16)1G2M Series
HY27SF(08/16)1G2M Series
1Gbit (128Mx8bit / 64Mx16bit) NAND Flash

3. DEVICE OPERATION

3.1 Page Read.

Upon initial device power up, the device defaults to Read mode. This operation is also initiated by writing 00h and 30h to the command register along with four address cycles. In two consecutive read operations, the second one doesn't need 00h command, which four address cycles and 30h command initiates that operation. Two types of operations are available : random read, serial page read. The random read mode is enabled when the page address is changed. The 2112 bytes (X8 device) or 1056 words (X16 device) of data within the selected page are transferred to the data registers in less than 27us(tR). The system controller may detect the completion of this data transfer (tR) by analyzing the output of R/B pin. Once the data in a page is loaded into the data registers, they may be read out in 60ns cycle time by sequentially pulsing RE#. The repetitive high to low transitions of the RE# clock make the device output the data starting from the selected column address up to the last column address.

The device may output random data in a page instead of the consecutive sequential data by writing random data output command.

The column address of next data, which is going to be out, may be changed to the address which follows random data output command.

Random data output can be operated multiple times regardless of how many times it is done in a page.

3.2 Page Program.

The device is programmed basically by page, but it does allow multiple partial page programming of a word or consecutive bytes up to 2112 (X8 device) or words up to 1056 (X16 device), in a single page program cycle. The number of consecutive partial page programming operation within the same page without an intervening erase operation must not exceed 4 times for main array (X8 device:1time/512byte, X16 device:1time/256word) and 4 times for spare array (X8 device:1time/16byte, X16 device:1time/8word).

The addressing should be done in sequential order in a block¹. A page program cycle consists of a serial data loading period in which up to 2112bytes (X8 device) or 1056words (X16 device) of data may be loaded into the data register, followed by a non-volatile programming period where the loaded data is programmed into the appropriate cell.

The serial data loading period begins by inputting the Serial Data Input command (80h), followed by the four cycle address inputs and then serial data. The words other than those to be programmed do not need to be loaded. The device supports random data input in a page. The column address of next data, which will be entered, may be changed to the address which follows random data input command (85h). Random data input may be operated multiple times regardless of how many times it is done in a page.

The Page Program confirm command (10h) initiates the programming process. Writing 10h alone without previously entering the serial data will not initiate the programming process. The internal write state controller automatically executes the algorithms and timings necessary for program and verify, thereby freeing the system controller for other tasks. Once the program process starts, the Read Status Register command may be entered to read the status register. The system controller can detect the completion of a program cycle by monitoring the RB# output, or the Status bit (I/O 6) of the Status Register. Only the Read Status command and Reset command are valid while programming is in progress. When the Page Program is complete, the Write Status Bit (I/O 0) may be checked. The internal write verify detects only errors for "1"s that are not successfully programmed to "0"s. The command register remains in Read Status command mode until another valid command is written to the command register. Figure 13 details the sequence.

3.3 Block Erase.

The Erase operation is done on a block basis. Block address loading is accomplished in two cycles initiated by an Erase Setup command (60h). Only address A18 to A27 (X8) or A17 to A26 (X16) is valid while A12 to A17 (X8) or A11 to A16 (X16) is ignored. The Erase Confirm command (D0h) following the block address loading initiates the internal erasing process. This two-step sequence of setup followed by execution command ensures that memory contents are not accidentally erased due to external noise conditions.

At the rising edge of WE# after the erase confirm command input, the internal write controller handles erase and erase-verify.

Once the erase process starts, the Read Status Register command may be entered to read the status register. The system controller can detect the completion of an erase by monitoring the RB# output, or the Status bit (I/O 6) of the Status Register. Only the Read Status command and Reset command are valid while erasing is in progress. When the erase operation is completed, the Write Status Bit (I/O 0) may be checked.

Figure 17 details the sequence.

3.4 Copy-Back Program.

The copy-back program is configured to quickly and efficiently rewrite data stored in one page without utilizing an external memory. Since the time-consuming cycles of serial access and re-loading cycles are removed, the system performance is improved. The benefit is especially obvious when a portion of a block is updated and the rest of the block also need to be copied to the newly assigned free block. The operation for performing a copy-back program is a sequential execution of page-read without serial access and copying-program with the address of destination page. A read operation with "35h" command and the address of the source page moves the whole 2112byte (X8 device) or 1056word (X16 device) data into the internal data buffer. As soon as the device returns to Ready state, Copy Back command (85h) with the address cycles of destination page may be written. The Program Confirm command (10h) is required to actually begin the programming operation. Data input cycle for modifying a portion or multiple distant portions of the source page is allowed as shown in Figure 15.

"When there is a program-failure at Copy-Back operation, error is reported by pass/fail status. But, if Copy-Back operations are accumulated over time, bit error due to charge loss is not checked by external error detection/correction scheme. For this reason, two bit error correction is recommended for the use of Copy-Back operation."

Figure 15 shows the command sequence for the copy-back operation.

3.5 Read Status Register.

The device contains a Status Register which may be read to find out whether read, program or erase operation is completed, and whether the program or erase operation is completed successfully. After writing 70h command to the command register, a read cycle outputs the content of the Status Register to the I/O pins on the falling edge of CE# or RE#, whichever occurs last. This two line control allows the system to poll the progress of each device in multiple memory connections even when RB# pins are common-wired. RE# or CE# does not need to be toggled for updated status. Refer to table 14 for specific Status Register definitions. The command register remains in Status Read mode until further commands are issued to it. Therefore, if the status register is read during a random read cycle, the read command (00h) should be given before starting read cycles. See figure 9 for details of the Read Status operation.

3.6 Read ID.

The device contains a product identification mode, initiated by writing 90h to the command register, followed by an address input of 00h. Four read cycles sequentially output the manufacturer code (ADh), and the device code and 00h, 4th cycle ID, respectively. The command register remains in Read ID mode until further commands are issued to it. Figure 18 shows the operation sequence, while tables 16, 17 explain the byte meaning.

3.7 Reset.

The device offers a reset feature, executed by writing FFh to the command register. When the device is in Busy state during random read, program or erase mode, the reset operation will abort these operations. The contents of memory cells being altered are no longer valid, as the data will be partially programmed or erased. The command register is cleared to wait for the next command, and the Status Register is cleared to value E0h when WP# is high. If the device is already in reset state a new reset command will not be accepted by the command register. The RB# pin transitions to low for tRST after the Reset command is written. Refer to figure 23.

3.8 Cache Program.

Cache Program is an extension of Page Program, which is executed with 2112byte (X8 device) or 1056word (X16 device) data registers, and is available only within a block. Since the device has 1 page of cache memory, serial data input may be executed while data stored in data register are programmed into memory cell. After writing the first set of data up to 2112byte (X8 device) or 1056word (X16 device) into the selected cache registers, Cache Program command (15h) instead of actual Page Program (10h) is input to make cache registers free and to start internal program operation. To transfer data from cache registers to data registers, the device remains in Busy state for a short period of time (tCBSY) and has its cache registers ready for the next data-input while the internal programming gets started with the data loaded into data registers. Read Status command (70h) may be issued to find out when cache registers become ready by polling the Cache-Busy status bit (I/O 6). Pass/fail status of only the previous page is available upon the return to Ready state. When the next set of data is input with the Cache Program command, tCBSY is affected by the progress of pending internal programming. The programming of the cache registers is initiated only when the pending program cycle is finished and the data registers are available for the transfer of data from cache registers. The status bit (I/O5) for internal Ready/Busy may be polled to identify the completion of internal programming. If the system monitors the progress of programming only with RB#, the last page of the target programming sequence must be programmed with actual Page Program command (10h). If the Cache Program command (15h) is used instead, status bit (I/O5) must be polled to find out when the last programming is actually finished before starting other operations such as read. Pass/fail status is available in two steps. I/O 1 returns with the status of the previous page upon Ready or I/O6 status bit changing to "1", and later I/O 0 with the status of current page upon true Ready (returning from internal programming) or I/O 5 status bit changing to "1". I/O 1 may be read together when I/O 0 is checked. See figure 16 for more details.

NOTE : Since programming the last page does not employ caching, the program time has to be that of Page Program.

However, if the previous program cycle with the cache data has not finished, the actual program cycle of the last page is initiated only after completion of the previous cycle, which can be expressed as the following formula.

tPROG= Program time for the last page+ Program time for the (last -1)th page -
(Program command cycle time + Last page data loading time)

3.9 Cache Read

Cache read operation allows automatic download of consecutive pages, up to the whole device. Immediately after 1st latency end, while user can start reading out data, device internally starts reading following page.

Start address of 1st page is at page start (A<10:0>=00h), after 1st latency time (tr), automatic data download will be uninterrupted. In fact latency time is 25us, while download of a page require at least 100us for x8 device (50us for x16 device).

Cache read operation command is like standard read, except for confirm code (30h for standard read, 31h for cache read) user can check operation status using :

- RB# ('0' means latency ongoing, download not possible, '1' means download of n page possible, even if device internally is active on n+1 page
- Status register (SR<6> behave like RB#, SR<5> is '0' when device is internally reading and '1' when device is idle)

To exit cache read operation a cache read exit command (34h) must be issued. this command can be given any time (both device idle and reading).

If device is active (SR<5>=0) it will go idle within 5us, while if it is not active, device itself will go busy for a time shorter then tRBSY before becoming again idle and ready to accept any further commands.

If user arrives reading last byte/word of the memory array, then has to stop by giving a cache read exit command.

Random data output is not available in cache read.

Cache read operation must be done only block by block if system needs to avoid reading also from invalid blocks.

4. OTHER FEATURES

4.1 Data Protection.

The device is designed to offer protection from any involuntary program/erase during power-transitions. An internal voltage detector disables all functions whenever Vcc is below about 1.1V(1.8V device), 2V(3.3V device). WP# pin provides hardware protection and is recommended to be kept at VIL during power-up and power-down. A recovery time of minimum 10us is required before internal circuit gets ready for any command sequences as shown in Figure 24. The two-step command sequence for program/erase provides additional software protection.

4.2 Ready/Busy.

The device has a Ready/Busy output that provides method of indicating the completion of a page program, erase, copy-back, cache program and random read completion. The RB# pin is normally high and goes to low when the device is busy (after a reset, read, program, erase operation). It returns to high when the internal controller has finished the operation. The pin is an open-drain driver thereby allowing two or more RB# outputs to be Or-tied. Because pull-up resistor value is related to tr(RB#) and current drain during busy (Ibusy), an appropriate value can be obtained with the following reference chart (Fig.25). Its value can be determined by the following guidance.

4.3 Power-On Auto-Read

The device is designed to offer automatic reading of the first page without command and address input sequence during power-on.

An internal voltage detector enables auto-page read functions when Vcc reaches about 1.8V. PRE pin controls activation of auto- page read function. Auto-page read function is enabled only when PRE pin is logic high state. Serial access may be done after power-on without latency. Power-On Auto Read mode is available only on 3.3V device (HY27UF(08/16)1G2M).

Parameter	Symbol	Min	Typ	Max	Unit
Valid Block Number	NvB	1004		1024	Blocks

Table 7: Valid Blocks Number

Symbol	Parameter	Value		Unit
		1.8V	3.3V	
TA	Ambient Operating Temperature (Commercial Temperature Range)	0 to 70	0 to 70	℃
	Ambient Operating Temperature (Extended Temperature Range)	-25 to 85	-25 to 85	℃
	Ambient Operating Temperature (Industrial Temperature Range)	-40 to 85	-40 to 85	℃
TBIAS	Temperature Under Bias	-50 to 125	-50 to 125	℃
TSTG	Storage Temperature	-65 to 150	-65 to 150	℃
V _{IO} (2)	Input or Output Voltage	-0.6 to 2.7	-0.6 to 4.6	V
V _{CC}	Supply Voltage	-0.6 to 2.7	-0.6 to 4.6	V

Table 8: Absolute maximum ratings

NOTE:

1. Except for the rating "Operating Temperature Range", stresses above those listed in the Table "Absolute Maximum Ratings" may cause permanent damage to the device. These are stress ratings only and operation of the device at these or any other conditions above those indicated in the Operating sections of this specification is not implied. Exposure to Absolute Maximum Rating conditions for extended periods may affect device reliability.
2. Minimum Voltage may undershoot to -2V during transition and for less than 20ns during transitions.

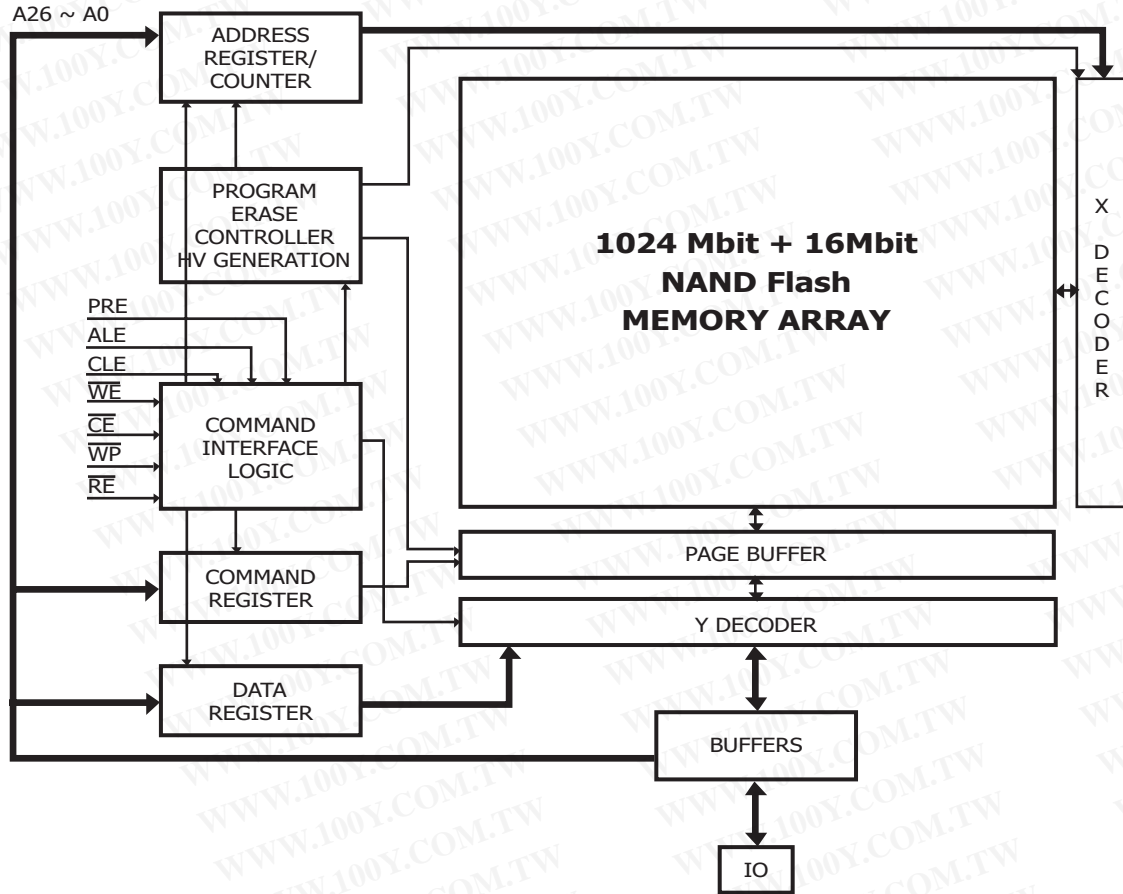

Figure 4: Block Diagram



HY27UF(08/16)1G2M Series
HY27SF(08/16)1G2M Series
1Gbit (128Mx8bit / 64Mx16bit) NAND Flash

Parameter	Symbol	Test Conditions	1.8Volt			3.3Volt			Unit			
			Min	Typ	Max	Min	Typ	Max				
Operating Current	Sequential Read	I _{CC1}	trc(1.8V=60ns, 3.3V=50ns) CE#=V _{IL} , I _{OUT} =0mA			-	8	15	-	10	20	mA
	Program	I _{CC2}	-			-	8	15	-	10	20	mA
	Erase	I _{CC3}	-			-	8	15	-	10	20	mA
Stand-by Current (TTL)	I _{CC4}	CE#=V _{IH} , PRE=WP#=0V/V _{CC}			-	-	1	-	-	1	mA	
Stand-by Current (CMOS)	I _{CC5}	CE#=V _{CC} -0.2, PRE=WP#=0V/V _{CC}			-	10	50	-	10	50	uA	
Input Leakage Current	I _{LI}	V _{IN} =0 to V _{CC} (max)			-	-	± 10	-	-	± 10	uA	
Output Leakage Current	I _{LO}	V _{OUT} =0 to V _{CC} (max)			-	-	± 10	-	-	± 10	uA	
Input High Voltage	V _{IH}	-			V _{CC} -0.4	-	V _{CC} +0.3	2	-	V _{CC} +0.3	V	
Input Low Voltage	V _{IL}	-			-0.3	-	0.4	-0.3	-	0.8	V	
Output High Voltage Level	V _{OH}	I _{OH} =-100uA			V _{CC} -0.1	-	-	-	-	-	V	
		I _{OH} =-400uA			-	-	-	2.4	-	-	V	
Output Low Voltage Level	V _{OL}	I _{OL} =100uA			-	-	0.1	-	-	-	V	
		I _{OL} =2.1mA			-	-	-	-	-	0.4	V	
Output Low Current (RB#)	I _{OL} (RB#)	V _{OL} =0.1V			3	4	-	-	-	-	mA	
		V _{OL} =0.4V			-	-	-	8	10	-	mA	

Table 9: DC and Operating Characteristics

Parameter	Value	
	1.8Volt	3.3Volt
Input Pulse Levels	0V to V _{CC}	0.4V to 2.4V
Input Rise and Fall Times	5ns	5ns
Input and Output Timing Levels	V _{CC} / 2	1.5V
Output Load (1.7V - 1.95V & 2.7V - 3.3V)	1 TTL GATE and CL=30pF	1 TTL GATE and CL=50pF
Output Load (3.0V - 3.6V)		1 TTL GATE and CL=100pF

Table 10: AC Conditions



HY27UF(08/16)1G2M Series
HY27SF(08/16)1G2M Series
1Gbit (128Mx8bit / 64Mx16bit) NAND Flash

Item	Symbol	Test Condition	Min	Max	Unit
Input / Output Capacitance	C _{I/O}	V _{IL} =0V	-	10	pF
Input Capacitance	C _{IN}	V _{IN} =0V	-	10	pF

Table 11: Pin Capacitance (TA=25C, F=1.0MHz)

Parameter	Symbol	Min	Typ	Max	Unit
Program Time	t _{PROG}	-	300	700	us
Dummy Busy Time for Cache Program	t _{CBSY}	-	3	700	us
Number of partial Program Cycles in the same page	Main Array	NOP	-	4	Cycles
	Spare Array	NOP	-	4	Cycles
Block Erase Time	t _{BERS}	-	2	3	ms

Table 12: Program / Erase Characteristics



HY27UF(08/16)1G2M Series
HY27SF(08/16)1G2M Series
1Gbit (128Mx8bit / 64Mx16bit) NAND Flash

Parameter	Symbol	1.8Volt		3.3Volt		Unit
		Min	Max	Min	Max	
CLE Setup time	tCLS	5		5		ns
CLE Hold time	tCLH	15		15		ns
CE# setup time	tCS	0		0		ns
CE# hold time	tCH	10		10		ns
WE# pulse width	tWP	40		40		ns
ALE setup time	tALS	5		5		ns
ALE hold time	tALH	15		15		ns
Data setup time	tDS	25		25		ns
Data hold time	tDH	15		15		ns
Write Cycle time	tWC	60		60		ns
WE# High hold time	tWH	20		20		ns
ALE to Data Loading time	tADL ⁽²⁾	100		100		ns
Data Transfer from Cell to register	tR		27		27	us
ALE to RE# Delay	tAR	10		10		ns
CLE to RE# Delay	tCLR	10		10		ns
Ready to RE# Low	tRR	20		20		ns
RE# Pulse Width (ID Read)	tRP	25		25		ns
RE# Pulse Width (Data Read)	tRP	25		25		ns
WE# High to Busy	tWB		100		100	ns
Read Cycle Time (ID Read)	tRC	60		60		ns
Read Cycle Time (Data Read)	tRC	50		50		ns
RE# Access Time	tREA		30		30	ns
RE# High to Output High Z	tRHZ		30		30	ns
CE# High to Output High Z	tCHZ		20		20	ns
RE or CE High to Output hold	tOH	15		15		ns
RE# High Hold Time (ID Read)	tREH	30		30		ns
RE# High Hold Time (Data Read)	tREH	20		20		ns
Output High Z to RE# low	tIR	0		0		ns
CE# Access Time	tCEA		45		45	ns
WE# High to RE# low	tWHR	60		60		ns
Device Resetting Time (Read / Program / Erase)	tRST		5/10/500 ⁽¹⁾		5/10/500 ⁽¹⁾	us
Write Protection time	tWW ⁽³⁾	100		100		ns

Table 13: AC Timing Characteristics

NOTE:

1. If Reset Command (FFh) is written at Ready state, the device goes into Busy for maximum 5us
2. tADL is the time from the WE# rising edge of final address cycle to the WE# rising edge of first data cycle.
3. Program / Erase Enable Operation : tWP# high to tWE# High.
 Program / Erase Disable Operation : tWP# Low to tWE# High.



IO	Page Program	Block Erase	Cache Program	Read	Cache Read	CODING
0	Pass / Fail	Pass / Fail	Pass / Fail (N)	NA		Pass: '0' Fail: '1'
1	NA	NA	Pass / Fail (N-1)	NA		Pass: '0' Fail: '1' (Only for Cache Program, else Don't care)
2	NA	NA	NA	NA		-
3	NA	NA	NA	NA		-
4	NA	NA	NA	NA		-
5	Ready/Busy	Ready/Busy	P/E/R Controller Bit	Ready/Busy	P/E/R Controller Bit	Active: '0' Idle: '1'
6	Ready/Busy	Ready/Busy	Cache Register Free	Ready/Busy	Ready/Busy	Busy: '0' Ready: '1'
7	Write Protect	Write Protect	Write Protect	Write Protect		Protected: '0' Not Protected: '1'

Table 14: Status Register Coding

DEVICE IDENTIFIER BYTE	DESCRIPTION
1st	Manufacturer Code
2nd	Device Identifier
3rd	Don't care
4th	Page Size, Block Size, Spare Size, Organization

Table 15: Device Identifier Coding

勝特力材料 886-3-5753170
 勝特力电子(上海) 86-21-54151736
 勝特力电子(深圳) 86-755-83298787
[Http://www.100y.com.tw](http://www.100y.com.tw)



HY27UF(08/16)1G2M Series
HY27SF(08/16)1G2M Series
1Gbit (128Mx8bit / 64Mx16bit) NAND Flash

	Description	IO7	IO6	IO5-4	IO3	IO2	IO1-0
Page Size (Without Spare Area)	1K 2K Reserved Reserved						0 0 0 1 1 0 1 1
Spare Area Size (Byte / 512Byte)	8 16					0 1	
Serial Access Time	Standard (50ns) Fast (30ns)				0 1		
Block Size (Without Spare Area)	64K 128K 256K Reserved			0 0 0 1 1 0 1 1			
Organization	X8 X16		0 1				
Not Used		Reserved					

Table 16: 4th Byte of Device Identifier Description

Part Number	Voltage	Bus Width	Manufacture Code	Device Code	3rd Code	4th Code
HY27UF081G2M	3.3V	x8	ADh	F1h	Don't care	15h
HY27UF161G2M	3.3V	x16	ADh	C1h	Don't care	55h
HY27SF081G2M	1.8V	x8	ADh	A1h	Don't care	15h
HY27SF161G2M	1.8V	x16	ADh	ADh	Don't care	55h

Table 17: Read ID Data Table

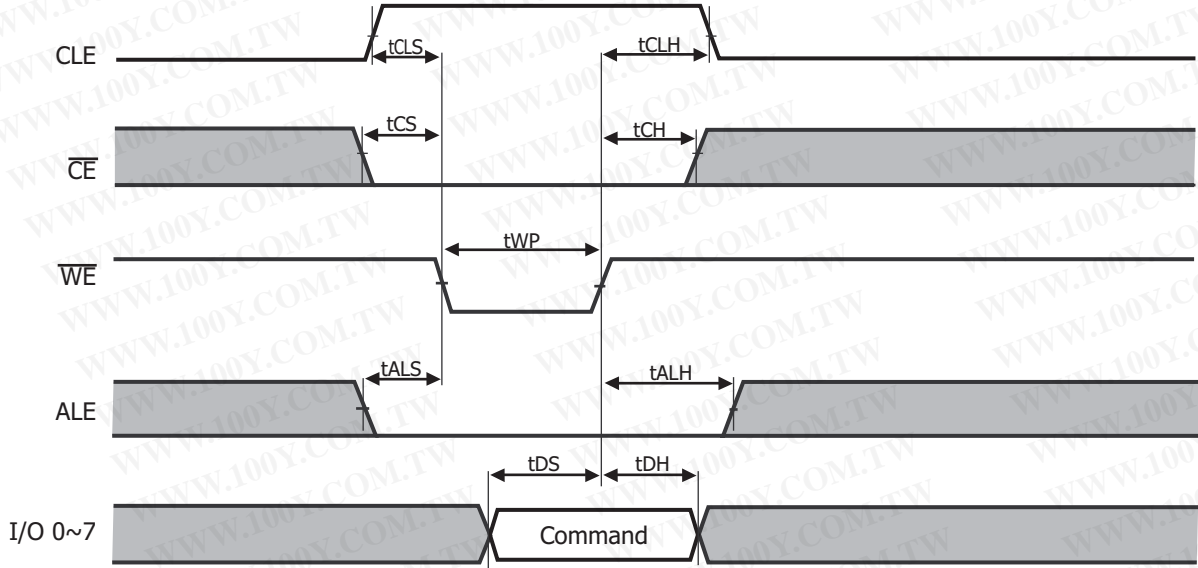

Figure 5: Command Latch Cycle

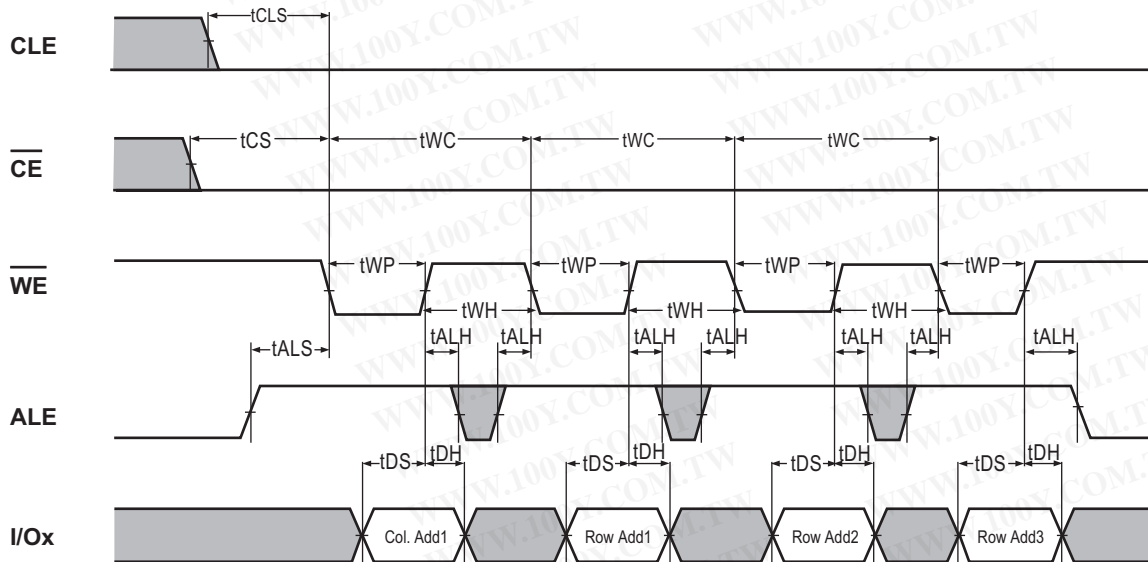

Figure 6: Address Latch Cycle

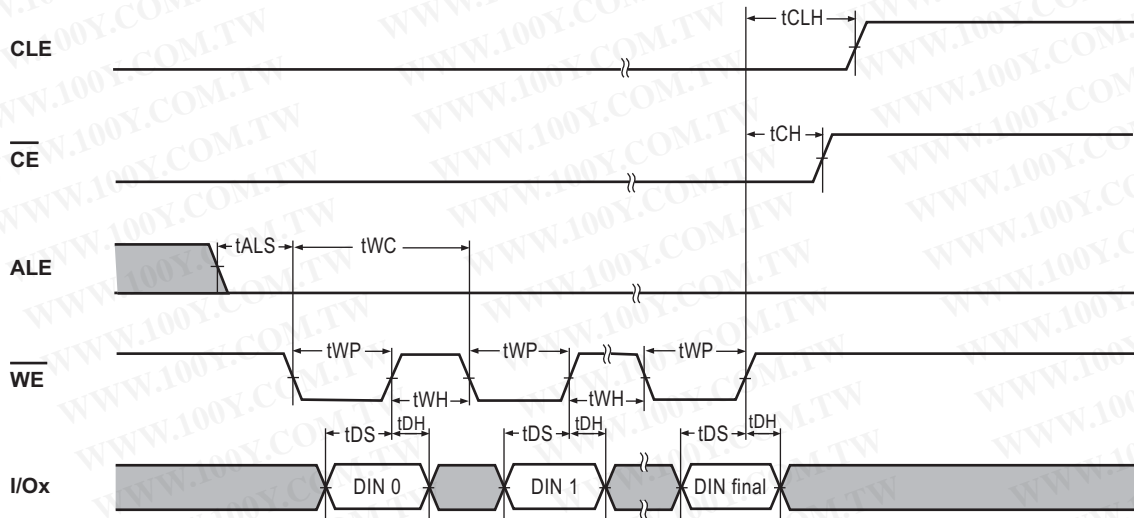
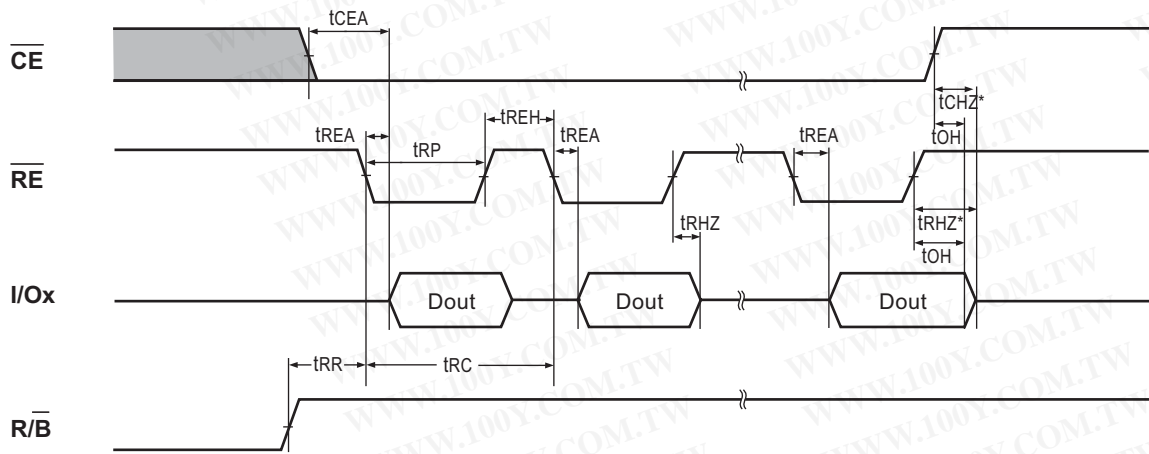

Figure 7. Input Data Latch Cycle



NOTES : Transition is measured $\pm 200\text{mV}$ from steady state voltage with load.
 This parameter is sampled and not 100% tested.

Figure 8: Sequential Out Cycle after Read (CLE=L, WE#=H, ALE=L)

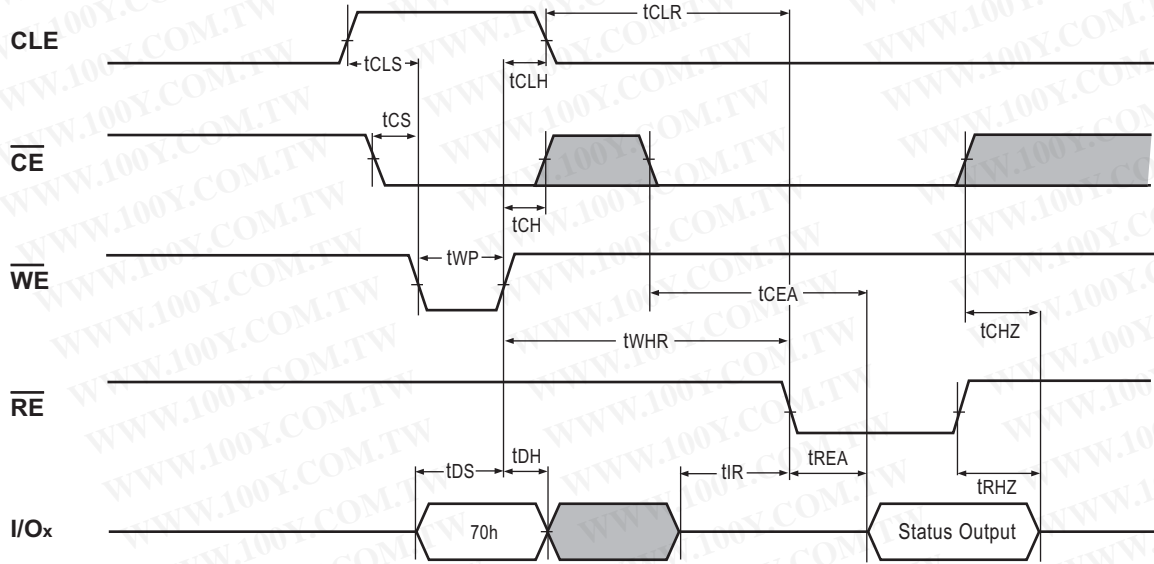

Figure 9: Status Read Cycle

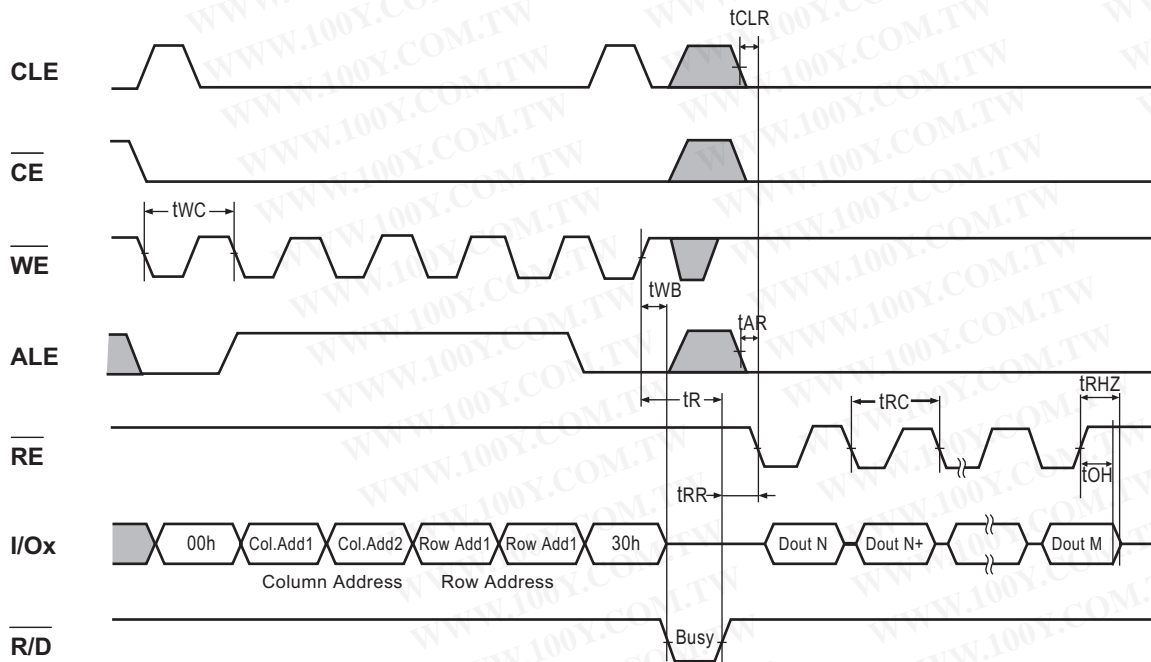

Figure 10: Read1 Operation (Read One Page)



HY27UF(08/16)1G2M Series
HY27SF(08/16)1G2M Series
1Gbit (128Mx8bit / 64Mx16bit) NAND Flash

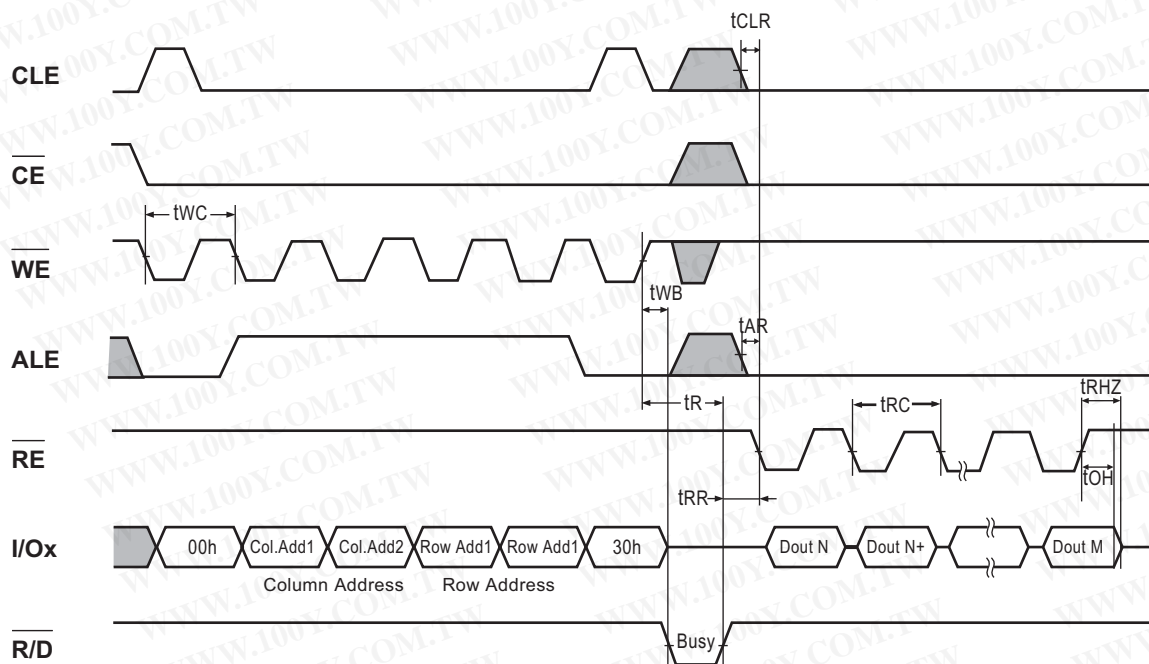

Figure 11: Read1 Operation intercepted by CE#

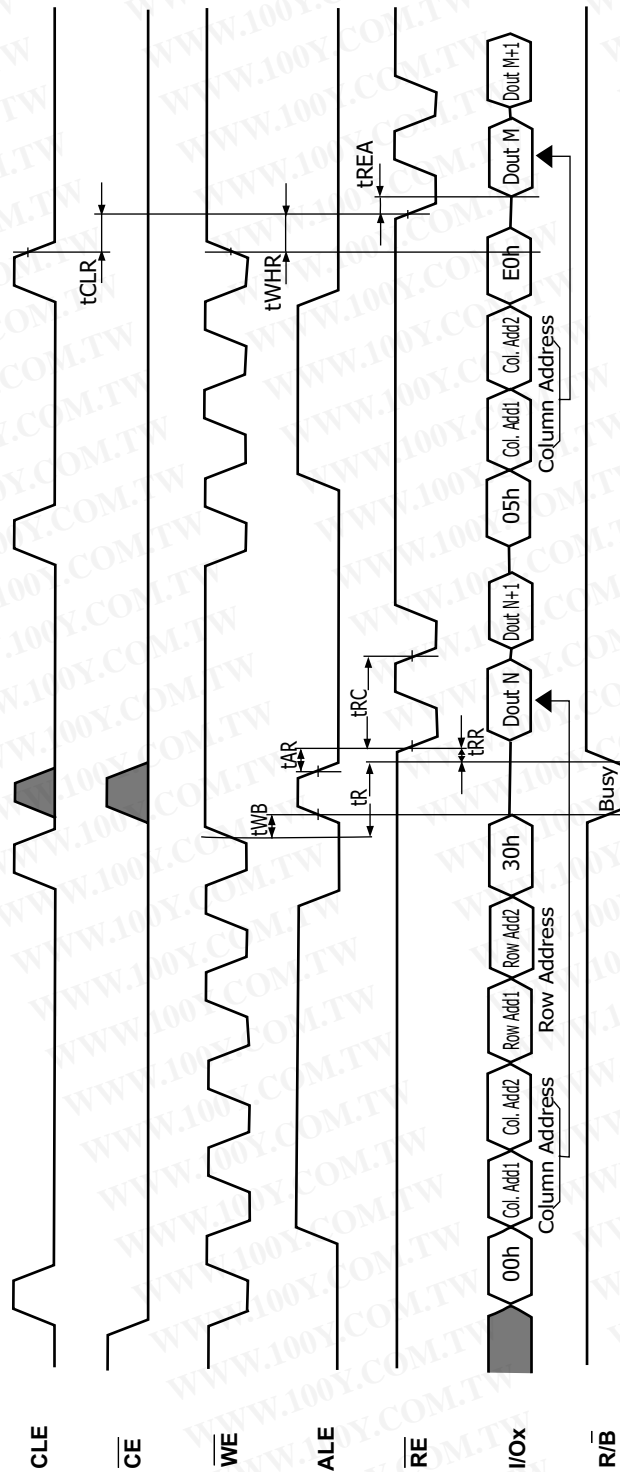
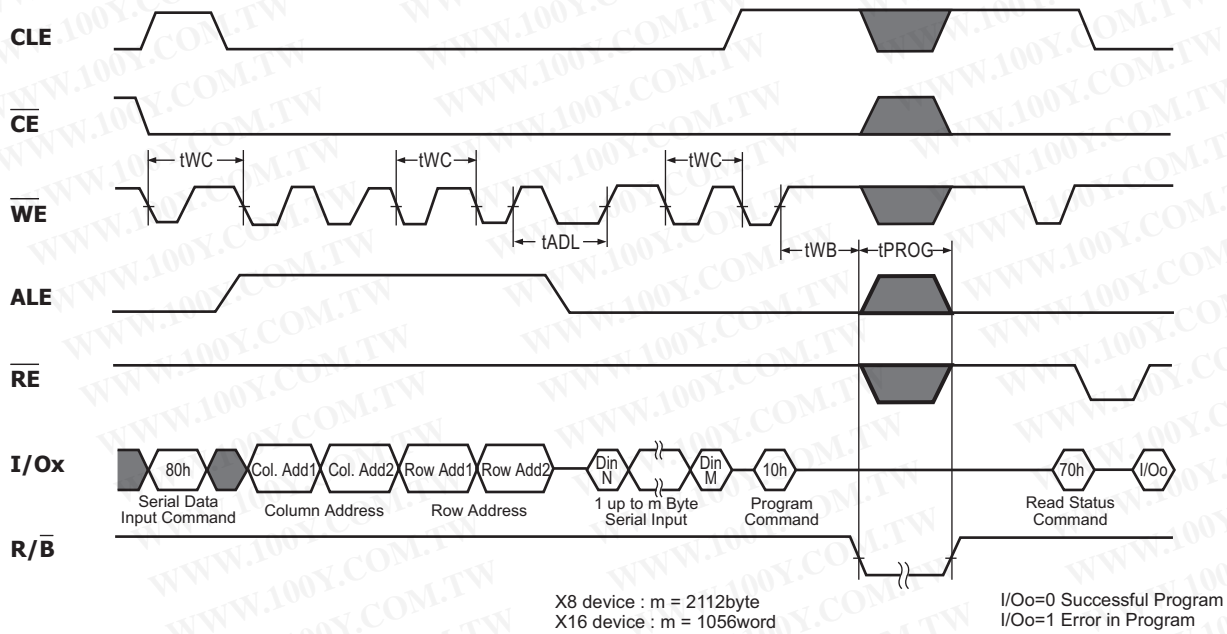

Figure 12 : Random Data output



Note : tADL is the time from the WE# rising edge of final address cycle to the WE# rising edge fo first data cycle.

Figure 13: Page Program Operation

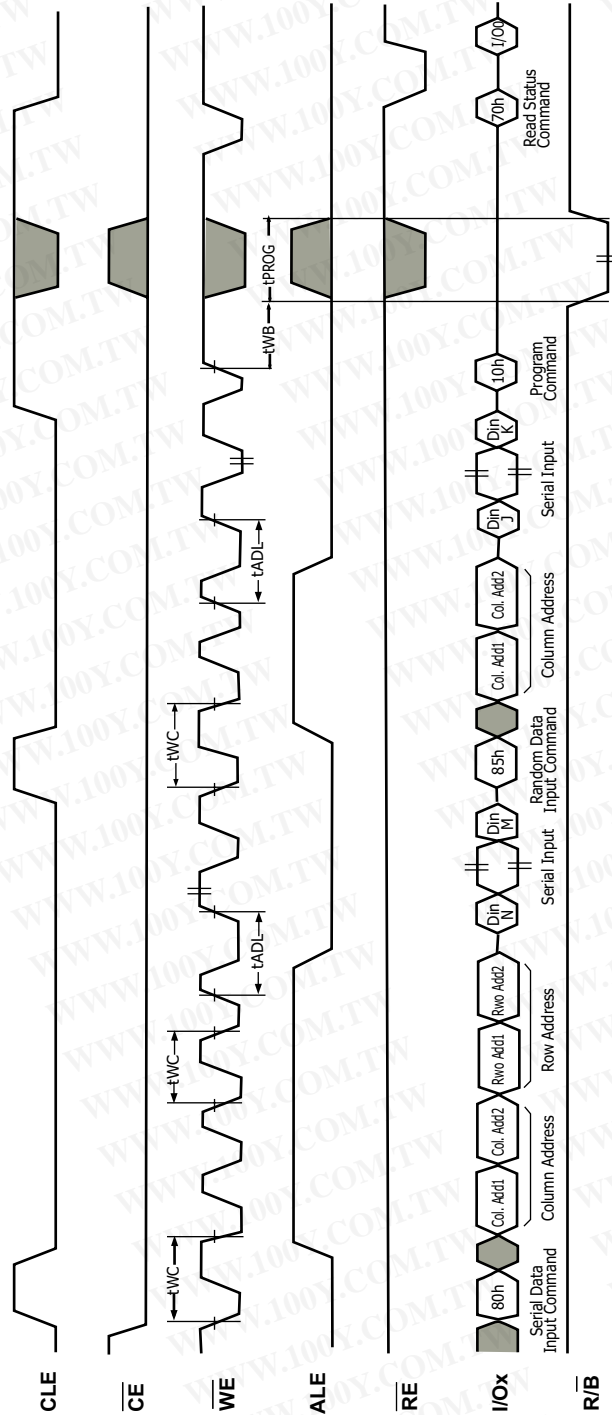
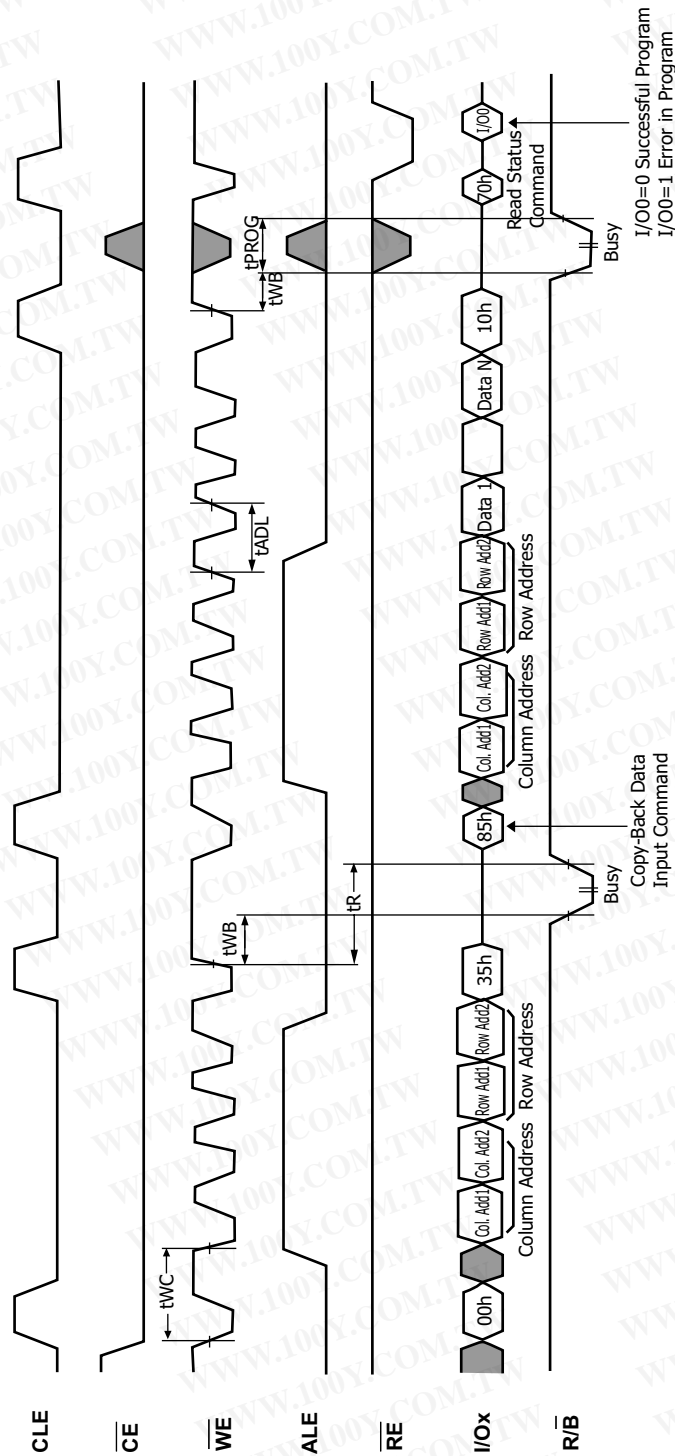

Figure 14 : Random Data In



Note : tADL is the time from the WE# rising edge of final address cycle to the WE# rising edge fo first data cycle.

Figure 15 : Copy Back Program

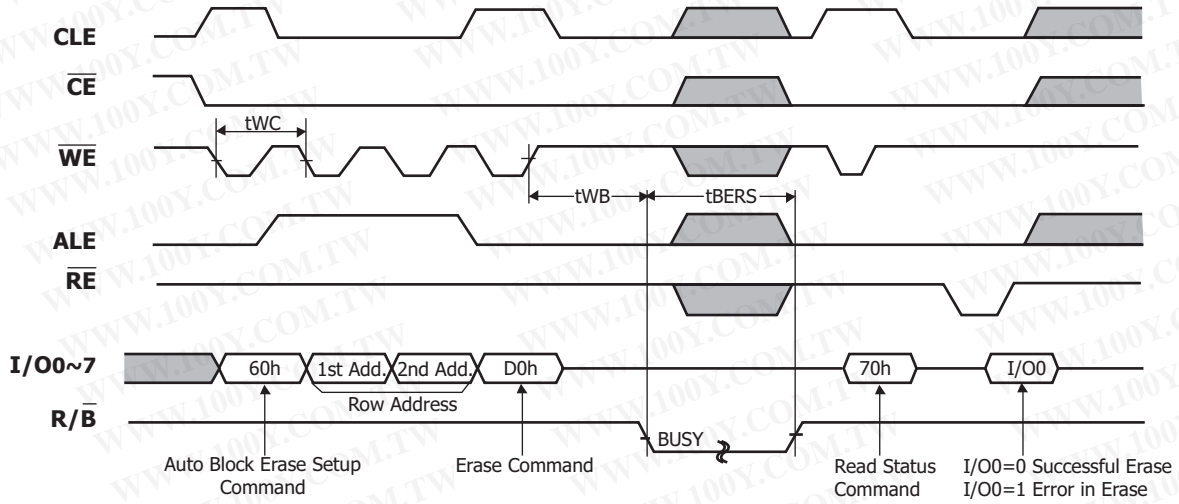

Figure 17: Block Erase Operation (Erase One Block)

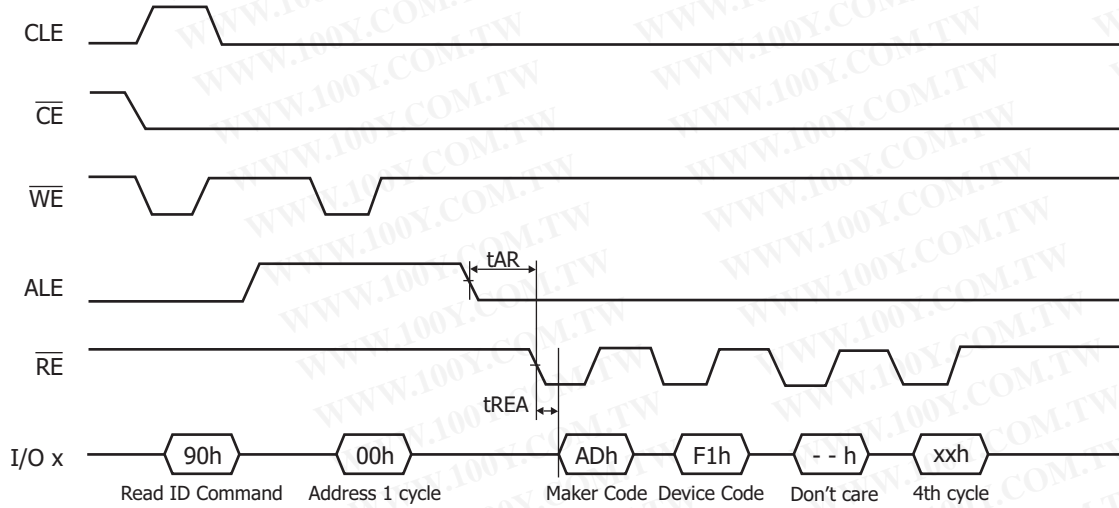

Figure 18: Read ID Operation



HY27UF(08/16)1G2M Series
HY27SF(08/16)1G2M Series

1Gbit (128Mx8bit / 64Mx16bit) NAND Flash

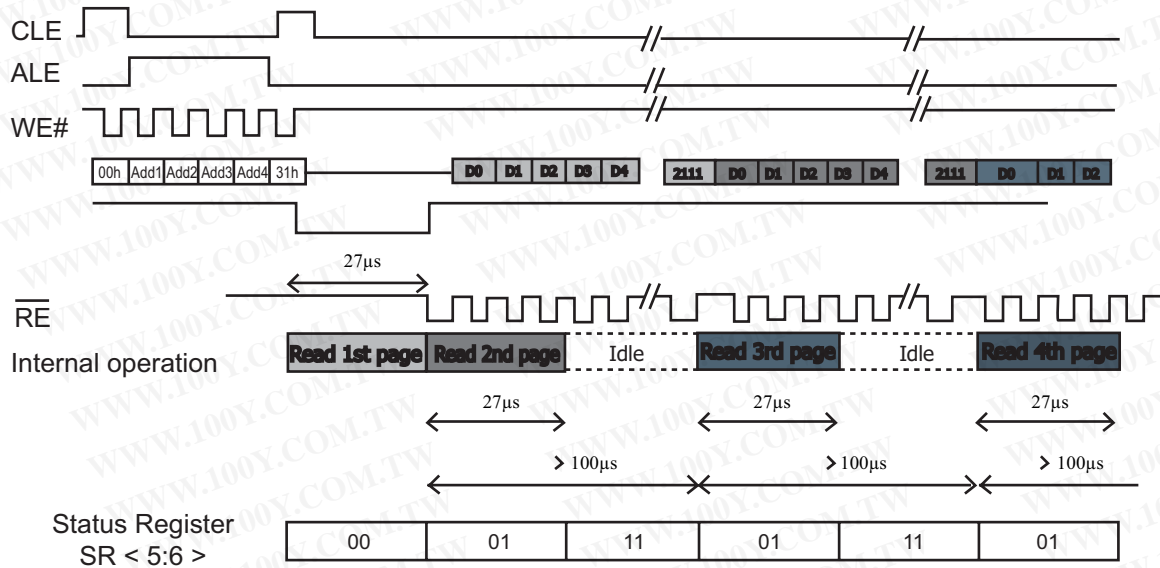

Figure 19: start address at page start :after 1st latency uninterrupted data flow

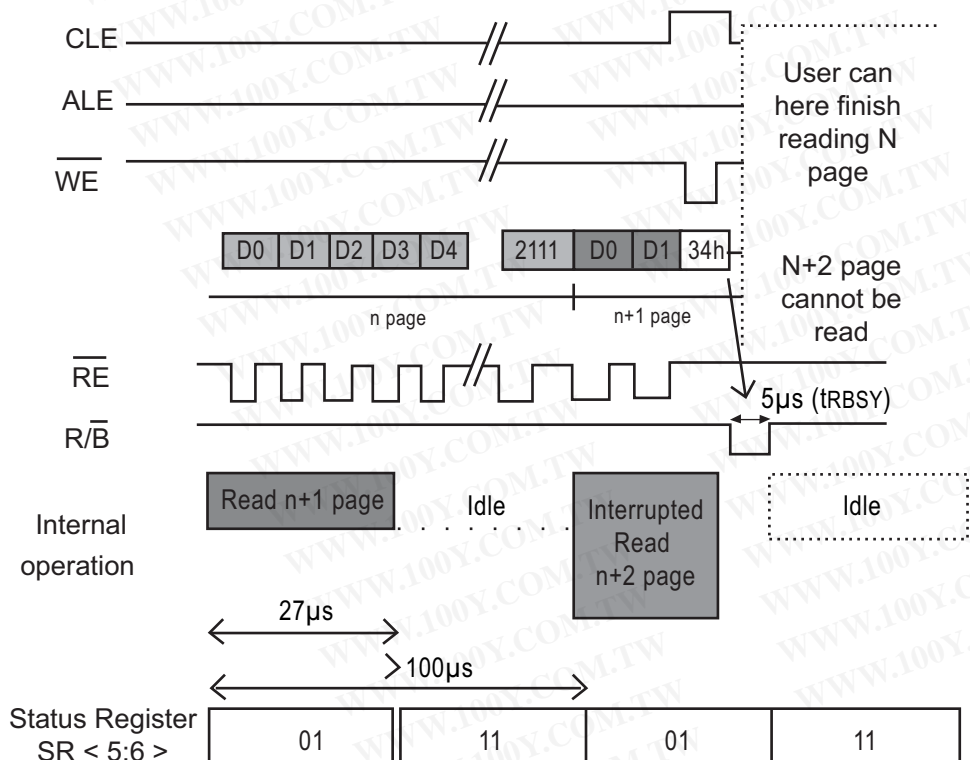

Figure 20: exit from cache read in 5us when device internally is reading

System Interface Using $\overline{\text{CE}}$ don't care

To simplify system interface, $\overline{\text{CE}}$ may be deasserted during data loading or sequential data-reading as shown below. So, it is possible to connect NAND Flash to a microprocessor. The only function that was removed from standard NAND Flash to make $\overline{\text{CE}}$ don't care read operation was disabling of the automatic sequential read function.

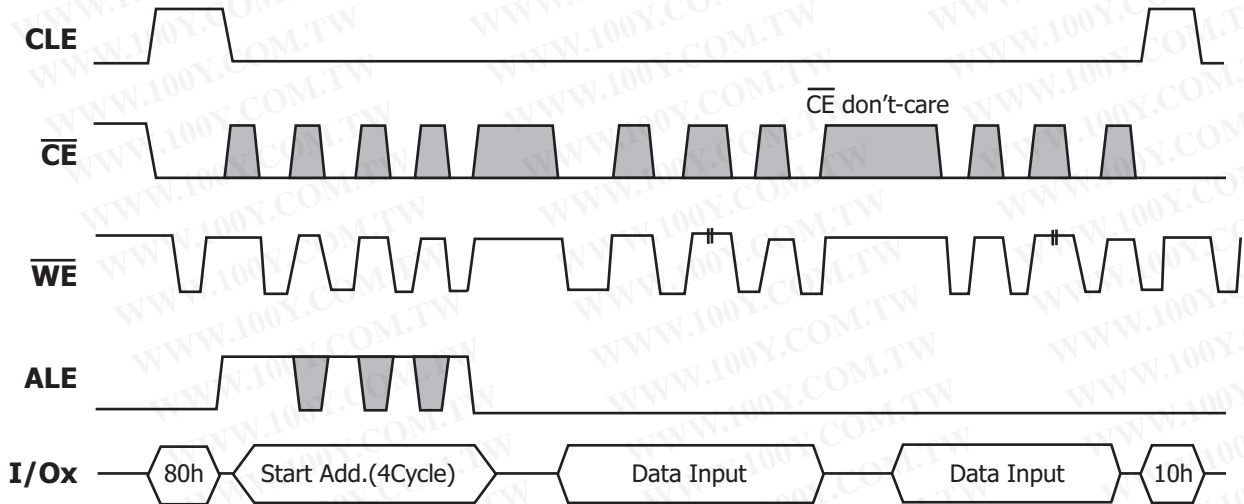

Figure 21: Program Operation with $\overline{\text{CE}}$ don't-care.

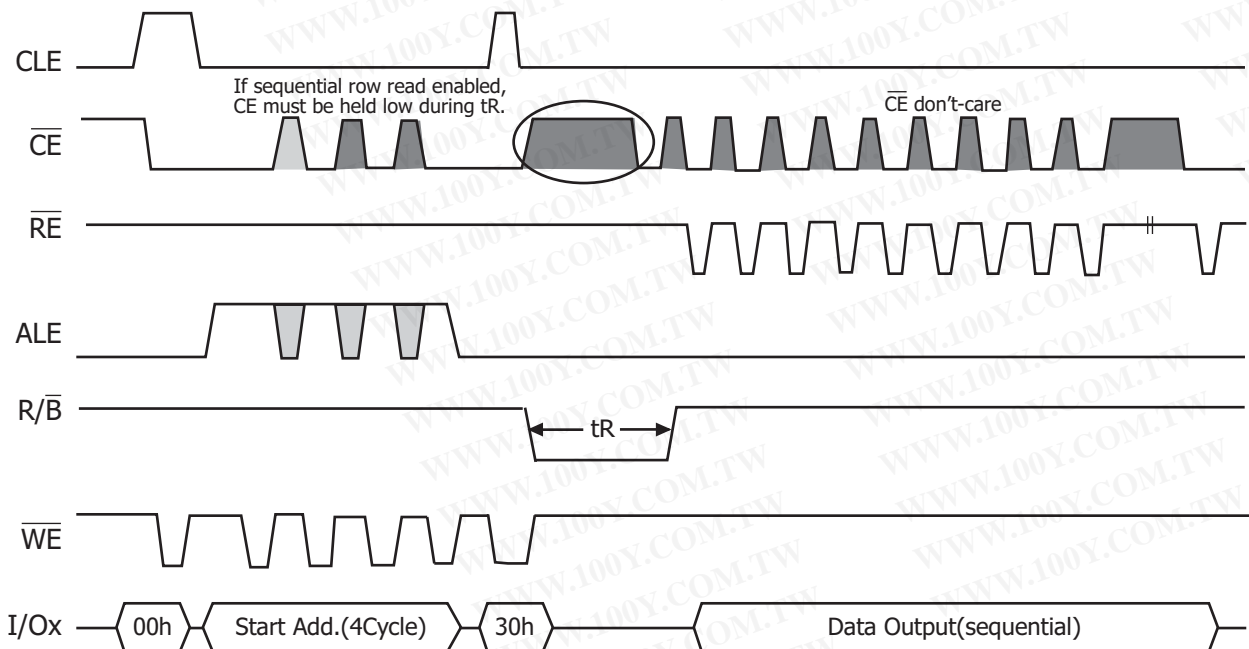

Figure 22: Read Operation with $\overline{\text{CE}}$ don't-care.



HY27UF(08/16)1G2M Series
HY27SF(08/16)1G2M Series
1Gbit (128Mx8bit / 64Mx16bit) NAND Flash

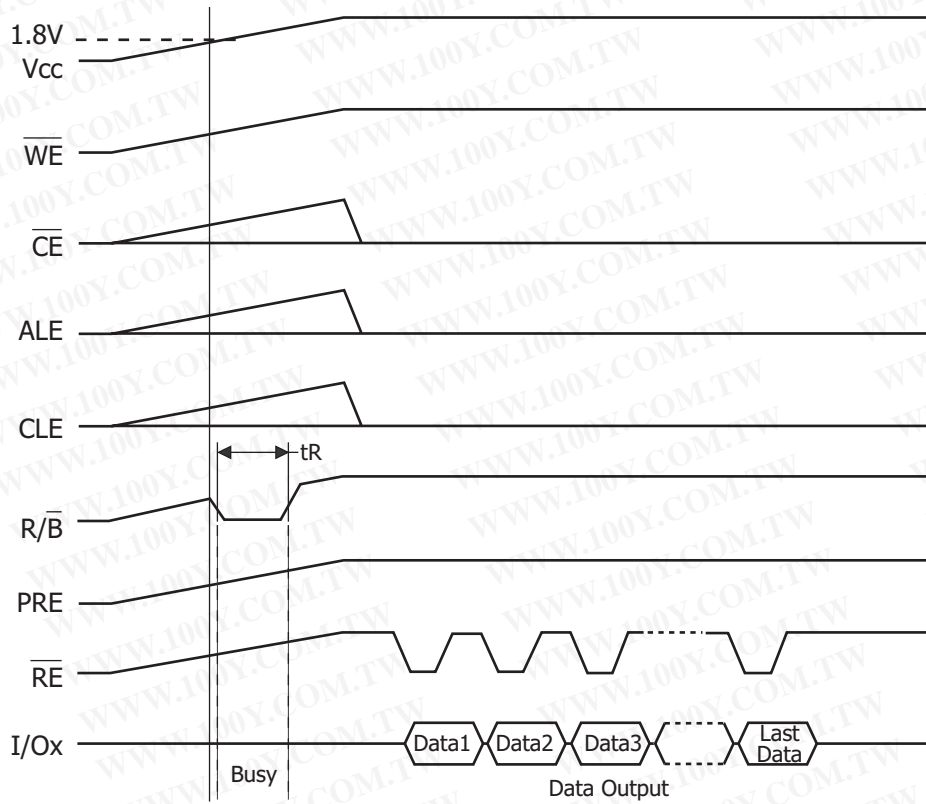

Figure 23: Automatic Read at Power On

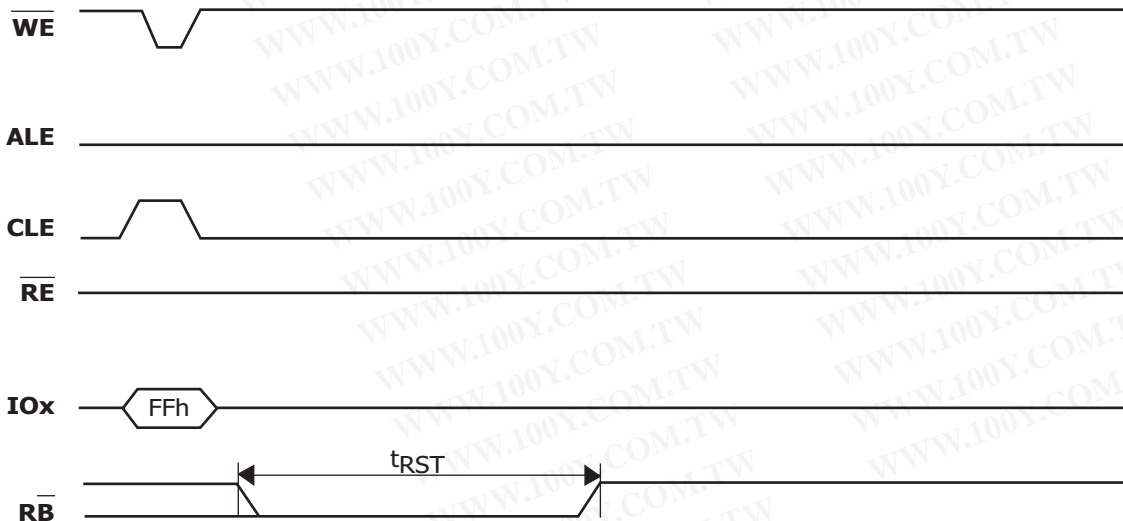

Figure 24: Reset Operation

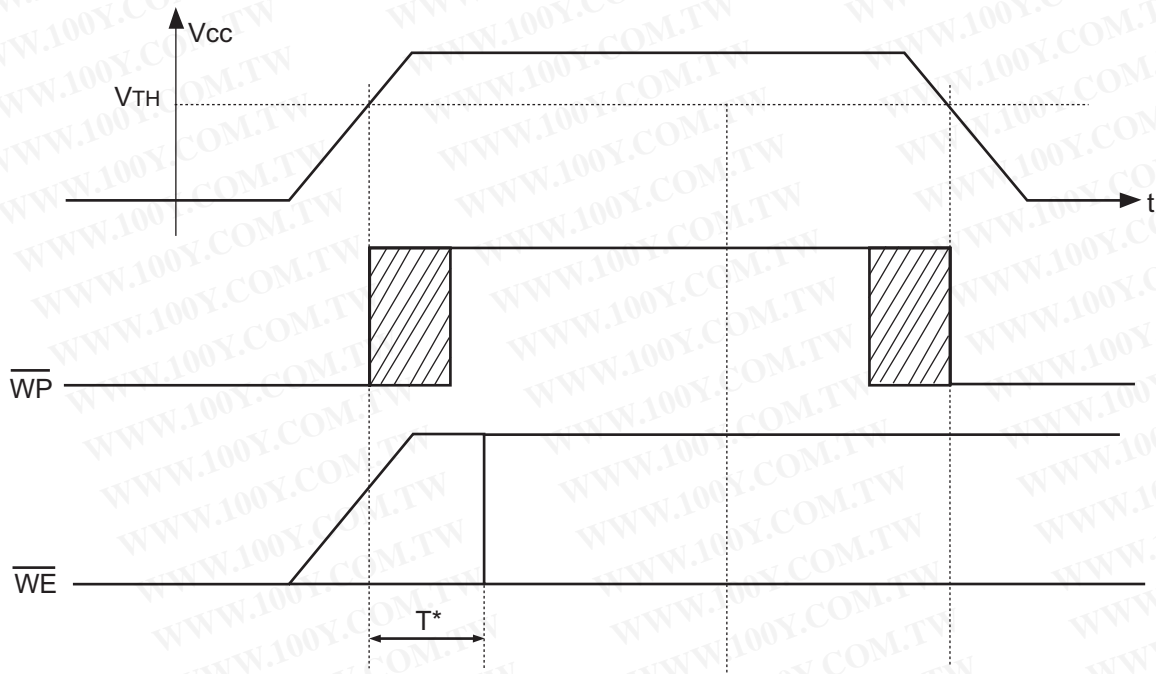

Figure 25: Power On and Data Protection Timing

* See the Application Note.1

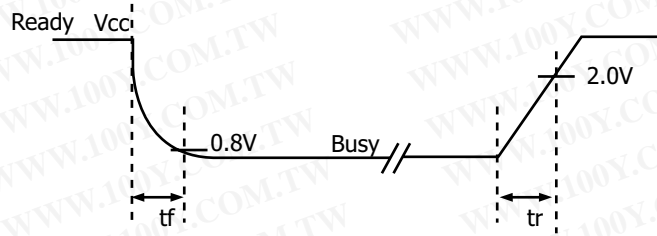
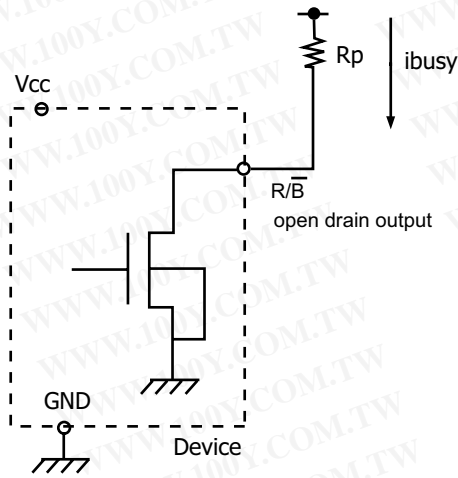
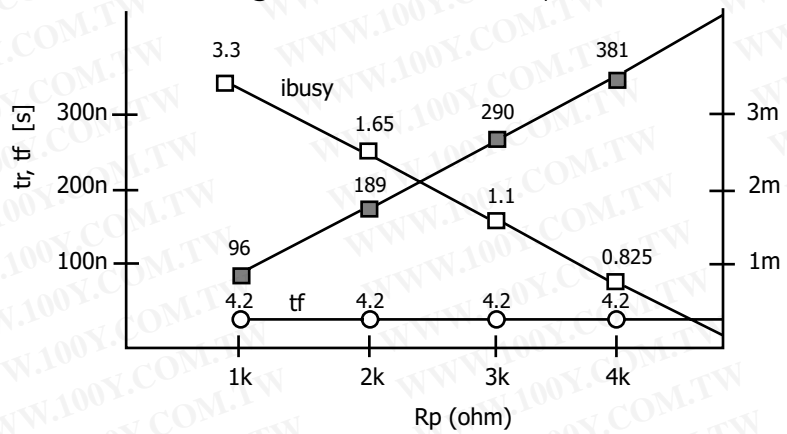

Fig. Rp vs tr, tf & Rp vs ibusy

@ Vcc = 3.3V, Ta = 25°C, Cl=100pF



Rp value guidance

$$R_p(\min) = \frac{V_{cc}(\text{Max.}) - V_{OL}(\text{Max.})}{I_{oL} + \sum I_L} = \frac{3.2V}{8mA + \sum I_L}$$

where IL is the sum of the input currents of all devices tied to the R/B pin.

Rp(max) is determined by maximum permissible limit of tr

Figure 26: Ready/Busy Pin electrical specifications



HY27UF(08/16)1G2M Series
HY27SF(08/16)1G2M Series
1Gbit (128Mx8bit / 64Mx16bit) NAND Flash

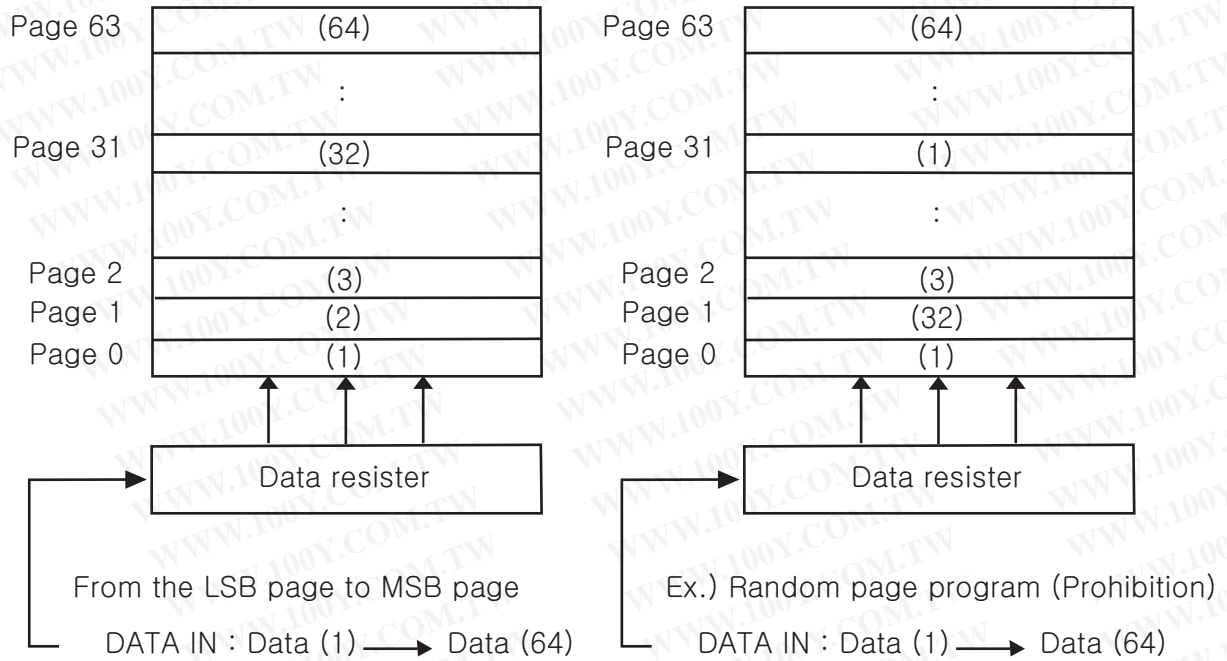

Figure 27: page programming within a block



Bad Block Management

Devices with Bad Blocks have the same quality level and the same AC and DC characteristics as devices where all the blocks are valid. A Bad Block does not affect the performance of valid blocks because it is isolated from the bit line and common source line by a select transistor. The devices are supplied with all the locations inside valid blocks erased(FFh). The Bad Block Information is written prior to shipping. Any block where the 1st Byte in the spare area of the 1st or 2nd page(if the 1st page is Bad) does not contain FFh is a Bad Block. The Bad Block Information must be read before any erase is attempted as the Bad Block Information may be erased. For the system to be able to recognize the Bad Blocks based on the original information it is recommended to create a Bad Block table following the flowchart shown in Figure 28. The 1st block, which is placed on 00h block address is guaranteed to be a valid block.

Block Replacement

Over the lifetime of the device additional Bad Blocks may develop. In this case the block has to be replaced by copying the data to a valid block. These additional Bad Blocks can be identified as attempts to program or erase them will give errors in the Status Register.

As the failure of a page program operation does not affect the data in other pages in the same block, the block can be replaced by re-programming the current data and copying the rest of the replaced block to an available valid block.

The Copy Back Program command can be used to copy the data to a valid block.

See the "Copy Back Program" section for more details.

Refer to Table 18 for the recommended procedure to follow if an error occurs during an operation.

Operation	Recommended Procedure
Erase	Block Replacement
Program	Block Replacement or ECC
Read	ECC

Table 18: Block Failure

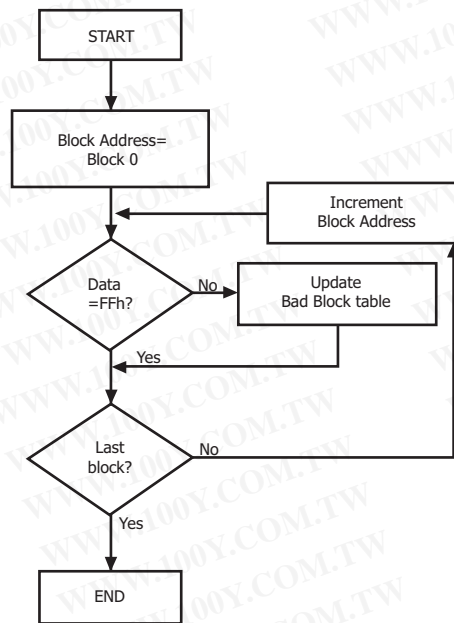

Figure 28: Bad Block Management Flowchart

Write Protect Operation

The Erase and Program Operations are automatically reset when \overline{WP} goes Low ($t_{WW} = 100\text{ns, min}$). The operations are enabled and disabled as follows (Figure 29~32)

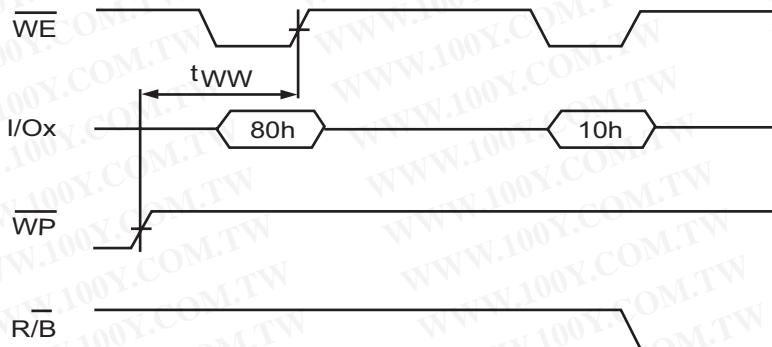

Figure 29: Enable Programming

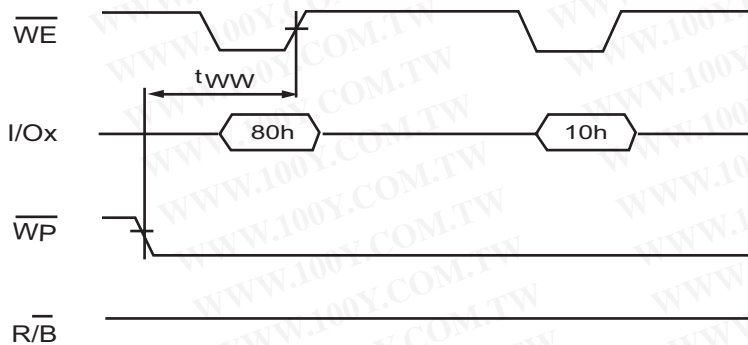

Figure 30: Disable Programming



HY27UF(08/16)1G2M Series
HY27SF(08/16)1G2M Series
1Gbit (128Mx8bit / 64Mx16bit) NAND Flash

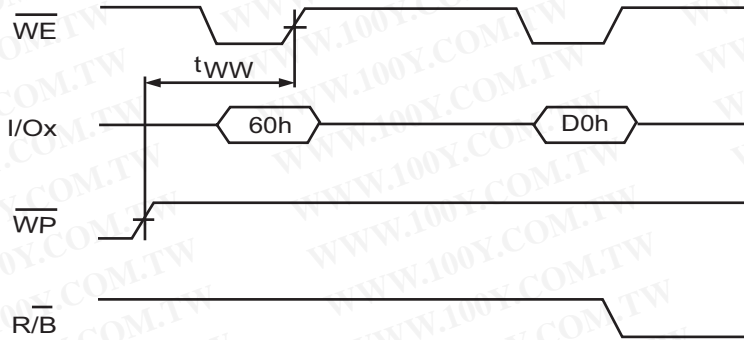

Figure 32: Enable Erasing

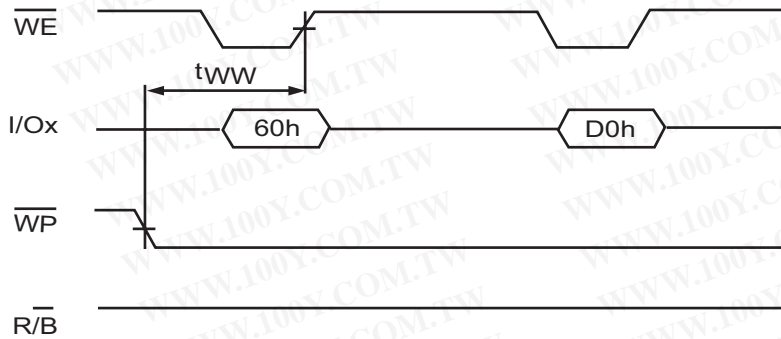

Figure 32: Disable Erasing

5. APPENDIX : Extra Features

5.1 Automatic Page0 Read after Power Up

The timing diagram related to this operation is shown in Fig. 22

Due to this functionality the CPU can directly download the boot loader from the first page of the NAND flash, storing it inside the internal cache and starting the execution after the download completed.

5.2 Addressing for program operation

Within a block, the pages must be programmed consecutively from LSB (least significant bit) page of the block to MSB (most significant bit) page of the block. Random address programming is prohibited. See Fig. 27.

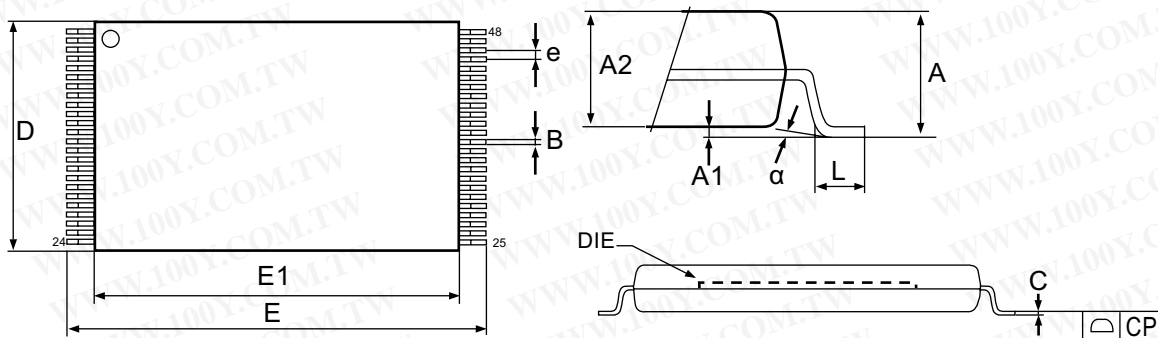

Figure 33. 48-pin TSOP1, 12 x 20mm, Package Outline

Symbol	millimeters		
	Min	Typ	Max
A			1.200
A1	0.050		0.150
A2	0.980		1.030
B	0.170		0.250
C	0.100		0.200
CP			0.100
D	11.910	12.000	12.120
E	19.900	20.000	20.100
E1	18.300	18.400	18.500
e		0.500	
L	0.500		0.680
alpha	0		5

Table 19: 48-TSOP1, 12 x 20mm, Package Mechanical Data

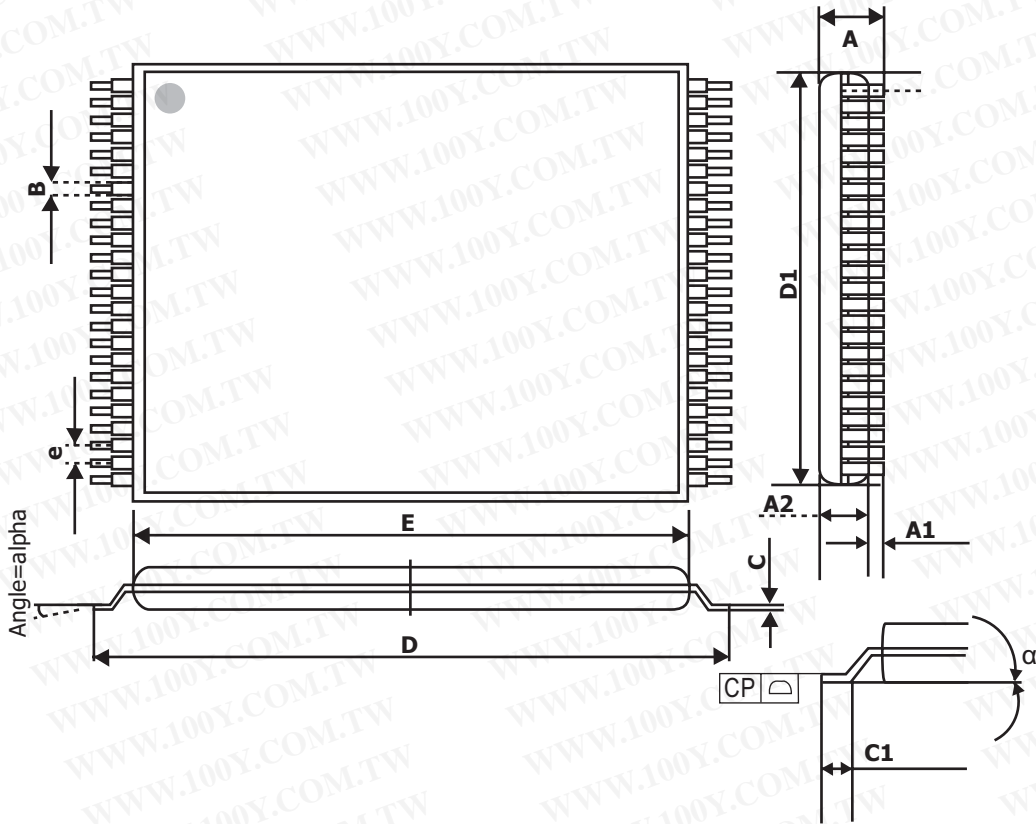

Figure 33. 48pin-USOP1, 12 x 17mm, Package Outline

Symbol	millimeters		
	Min	Typ	Max
A			0.650
A1	0	0.050	0.080
A2	0.470	0.520	0.570
B	0.130	0.160	0.230
C	0.065	0.100	0.175
C1	0.450	0.650	0.750
CP			0.100
D	16.900	17.000	17.100
D1	11.910	12.000	12.120
E	15.300	15.400	15.500
e		0.500	
alpha	0		8

Table 19: 48pin-USOP1, 12 x 17mm, Package Mechanical Data



MARKING INFORMATION- TSOP1 / USOP

Packag	Marking Example
<p>TSOP1 / USOP</p>	

- hynix	: Hynix Symbol
- KOR	: Origin Country
<hr/>	
- HY27xFxx1G2M xxxx	: Part Number
HY: HYNIX	
27: NAND Flash	
x: Power Supply	: U(2.7V ~ 3.6V), L(2.7V), S(1.8V)
F: Classification	: Single Level Cell+ Single Die+ Large Block
xx: Bit Organization	: 08(x8), 16(x16)
1G: Density	: 1Gbit
2: Mode	: 1nCE & 1R/nB; Sequential Row Read Disable
M: Version	: 1st Generation
<hr/>	
x: Package Type	: T(48-TSOP1), S(48-USOP)
x: Package Material	: Blank(Normal), P(Lead Free)
x: Operating Temperature	: C(0°C ~ 70°C), E(-25°C ~ 85°C) M(-30°C ~ 85°C), I(-40°C ~ 85°C)
x: Bad Block	: B(Included Bad Block), S(1~5 Bad Block), P(All Good Block)
- Y: Year (ex: 5=year 2005, 06= year 2006)	
- ww: Work Week (ex: 12= work week 12)	
- xx: Process Code	
<hr/>	
Note	
- Capital Letter	: Fixed Item
- Small Letter	: Non-fixed Item

Application Note

1. Power-on/off Sequence

After power is on, the device starts an internal circuit initialization when the power supply voltage reaches a specific level. The device shows its internal initialization status with the Ready/Busy signal if initialization is on progress. While the device is initializing, the device sets internal registries to default value and generates internal biases to operate circuits. Typically the initializing time of 20us is required.

Power-off or power failure before write/erase operation is complete will cause a loss of data. The WP# signal helps user to protect not only the data integrity but also device circuitry from being damaged at power-on/off by keeping WP# at VIL during power-on/off.

For the device to operate stably, it is highly recommended to operate the device as shown Fig.35.

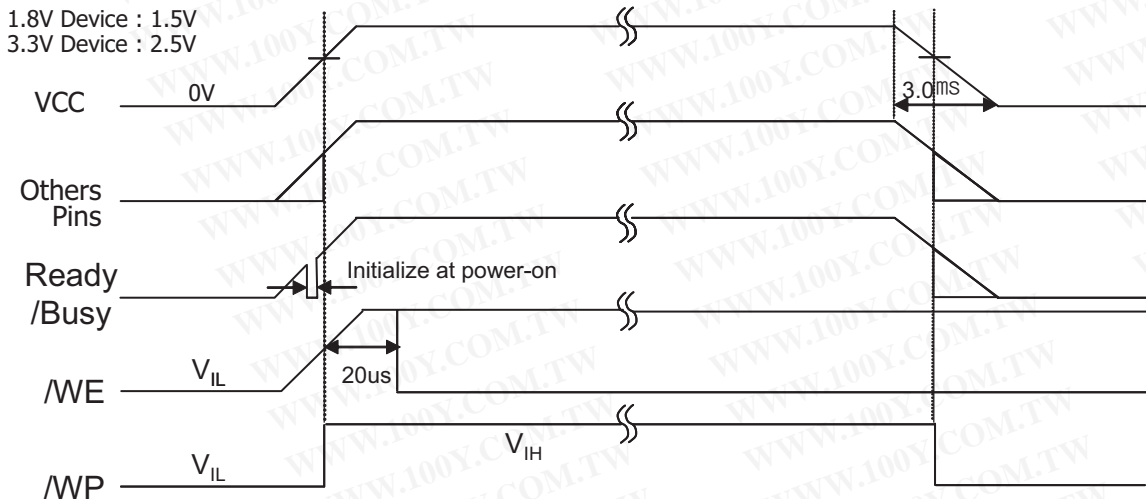

Figure 35: Power-on/off sequence

2. Automatic sleep mode for low power consumption

The device provides the automatic sleep function for low power consumption.

The device enters the automatic sleep mode by keeping CE# at VIH level for 10us without any additional command input, and exits simply by lowering CE# to VIL level.

Typically, consecutive operation is executable right after deactivating the automatic sleep mode, while tCS of 2us is required prior to following operation as shown in Fig.36.

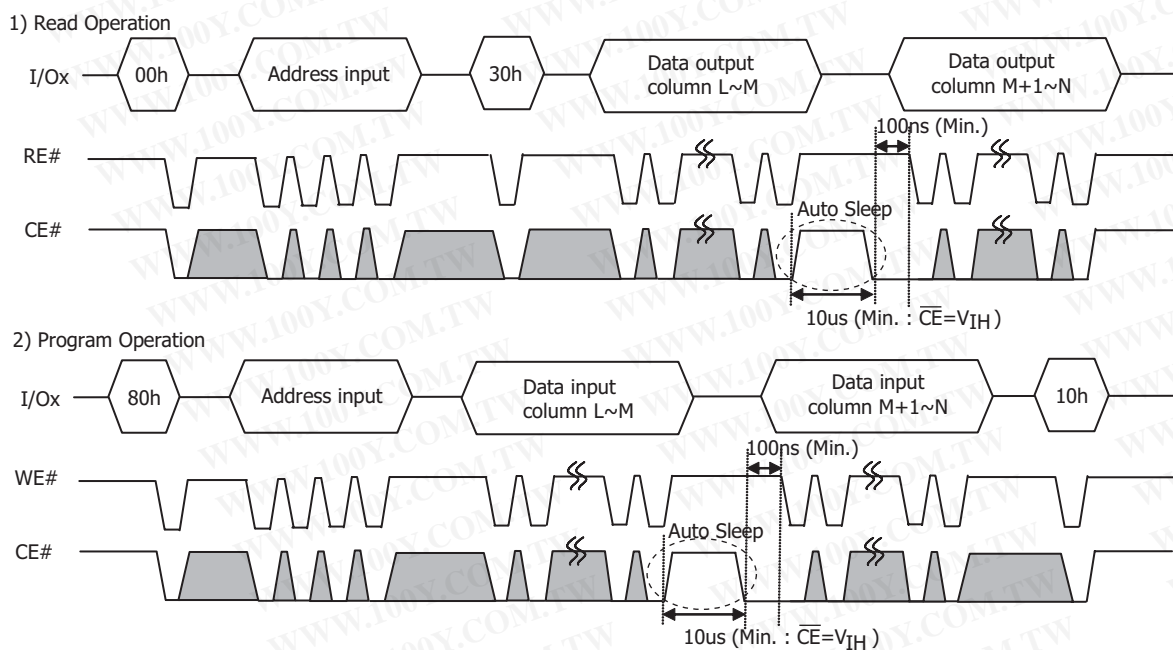

Figure 36: tCS setting when deactivating the auto sleep mode