

HD74HC164

8-bit Parallel-out Shift Register

HITACHI

勝特力材料 886-3-5753170
勝特力电子(上海) 86-21-54151736
勝特力电子(深圳) 86-755-83298787
[Http://www.100y.com.tw](http://www.100y.com.tw)





Description

This 8-bit shift register has gated serial inputs and clear. Each register bit is a D-type master/slave flip-flop. Inputs A & B permit complete control over the incoming data. A low at either or both inputs inhibits entry of new data and resets the first flip-flop to the low level at the next clock pulse. A high level on the input enables the other input which will then determine the state of the first flip-flop. Data at the serial inputs may be changed while the clock is high or low, but only information meeting the setup and hold time requirements will be entered. Data is serially shifted in and out of the 8-bit register during the positive going transition of the clock pulse. Clear is independent of the clock and accomplished by a low level at the clear input.

Features

- High Speed Operation: t_{pd} (Clock to Q) = 14.5 ns typ ($C_L = 50$ pF)
- High Output Current: Fanout of 10 LSTTL Loads
- Wide Operating Voltage: $V_{CC} = 2$ to 6 V
- Low Input Current: 1 μ A max
- Low Quiescent Supply Current: I_{CC} (static) = 4 μ A max

Function Table

Inputs				Outputs			
Clear	Clock	A	B	Q_A	Q_B	Q_H
L	X	X	X	L	L	L
H		X	X	Q_{Ao}	Q_{Bo}	Q_{Ho}
H		L	X	L	Q_{An}	Q_{Gn}
H		X	L	L	Q_{An}	Q_{Gn}
H		H	H	H	Q_{An}	Q_{Gn}

Q_{Ao} to Q_{Ho} = Outputs remain unchanged.

Q_{An} to Q_{Gn} = Data shifted from the previous stage on a positive edge at the clock input.

HD74HC164

Pin Arrangement

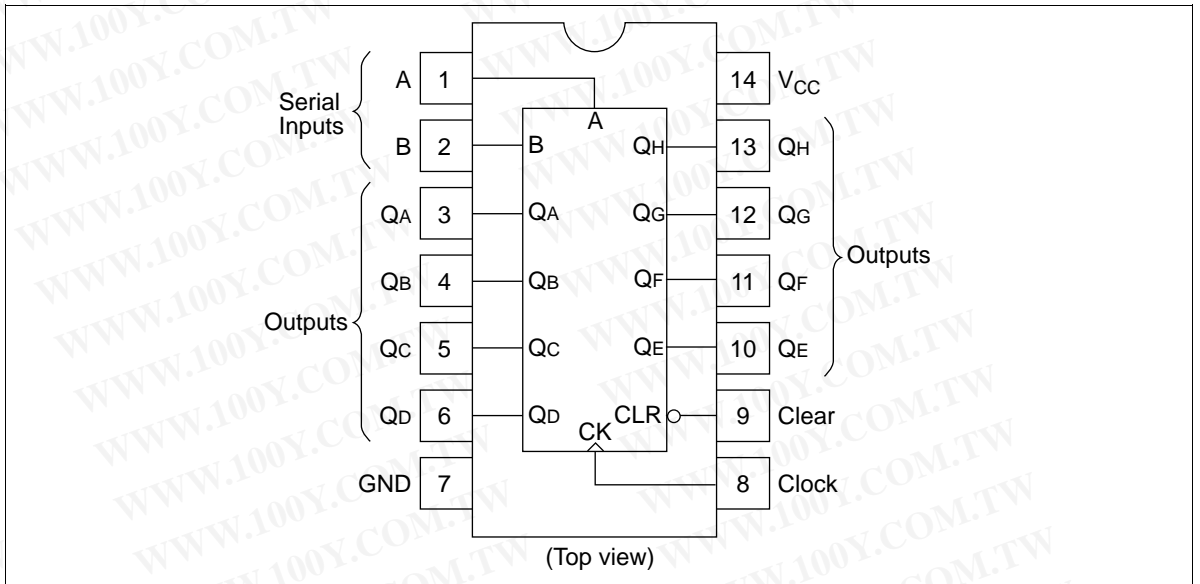

Timing Diagram

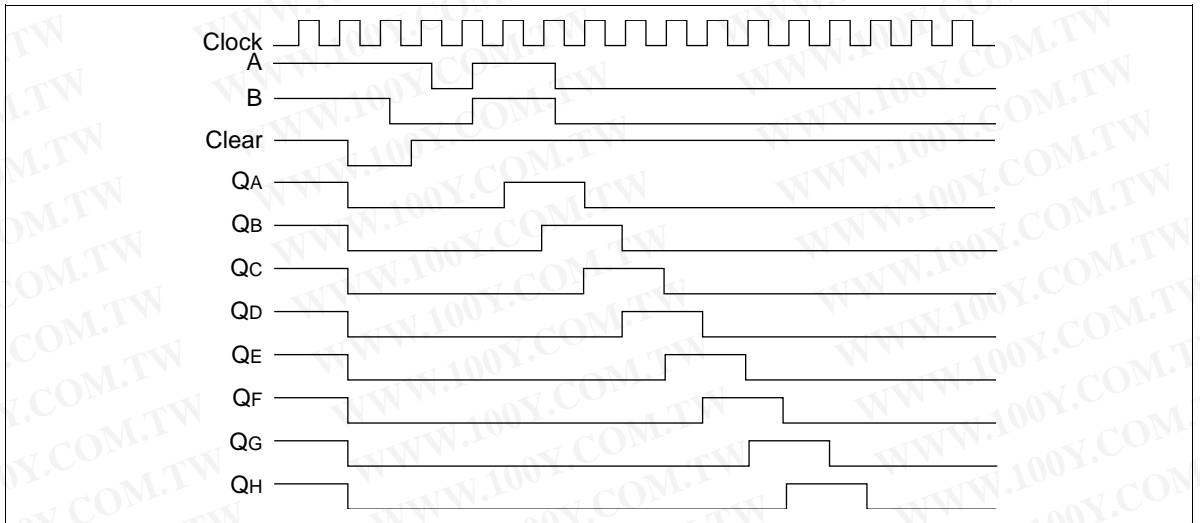

勝特力材料 886-3-5753170
勝特力电子(上海) 86-21-54151736
勝特力电子(深圳) 86-755-83298787
[Http://www.100y.com.tw](http://www.100y.com.tw)

HITACHI

Logic Diagram

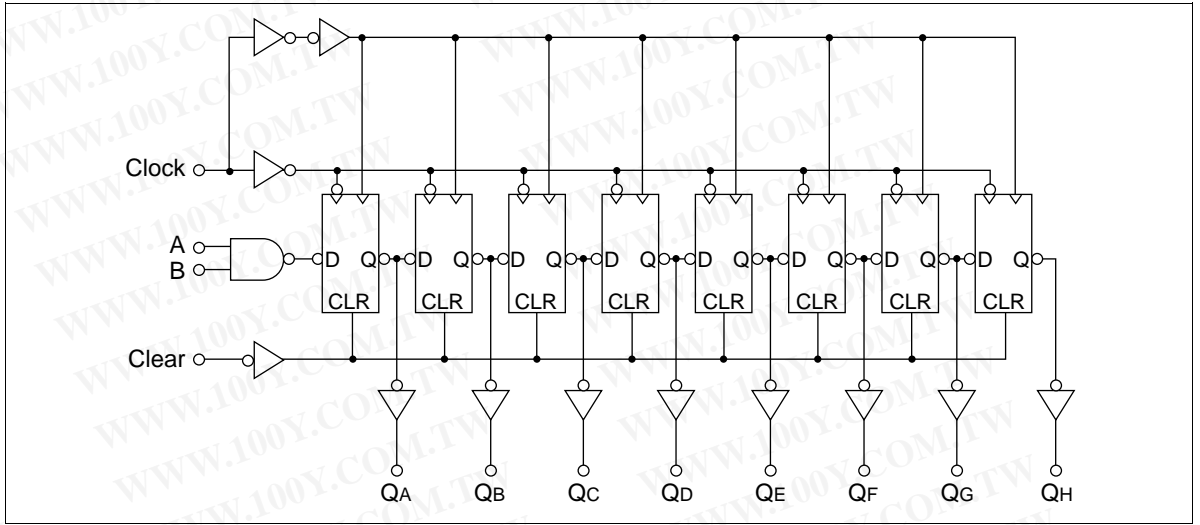

勝特力材料 886-3-5753170
 勝特力电子(上海) 86-21-54151736
 勝特力电子(深圳) 86-755-83298787
[Http://www.100y.com.tw](http://www.100y.com.tw)

HD74HC164

DC Characteristics

Item	Symbol	V _{CC} (V)	Ta = 25°C		Ta = -40 to +85°C		Unit	Test Conditions			
			Min	Typ	Max	Min			Max		
Input voltage	V _{IH}	2.0	1.5	—	—	1.5	—	V			
		4.5	3.15	—	—	3.15	—				
		6.0	4.2	—	—	4.2	—				
	V _{IL}	2.0	—	—	0.5	—	0.5		V		
		4.5	—	—	1.35	—	1.35				
		6.0	—	—	1.8	—	1.8				
Output voltage	V _{OH}	2.0	1.9	2.0	—	1.9	—	V		Vin = V _{IH} or V _{IL} I _{OH} = -20 μA	
		4.5	4.4	4.5	—	4.4	—				
		6.0	5.9	6.0	—	5.9	—				
		4.5	4.18	—	—	4.13	—		I _{OH} = -4 mA		
		6.0	5.68	—	—	5.63	—		I _{OH} = -5.2 mA		
		6.0	—	0.0	0.1	—	0.1		V		Vin = V _{IH} or V _{IL} I _{OL} = 20 μA
	V _{OL}	4.5	—	0.0	0.1	—	0.1				
		6.0	—	0.0	0.1	—	0.1				
		4.5	—	—	0.26	—	0.33	I _{OL} = 4 mA			
		6.0	—	—	0.26	—	0.33	I _{OL} = 5.2 mA			
		Input current	I _{in}	6.0	—	—	±0.1	—		±1.0	
		Quiescent supply current	I _{CC}	6.0	—	—	4.0	—	40	μA	Vin = V _{CC} or GND, I _{out} = 0 μA

勝特力材料 886-3-5753170
 勝特力电子(上海) 86-21-54151736
 勝特力电子(深圳) 86-755-83298787
[Http://www.100y.com.tw](http://www.100y.com.tw)

HITACHI

AC Characteristics ($C_L = 50 \text{ pF}$, Input $t_r = t_f = 6 \text{ ns}$)

Item	Symbol	V_{CC} (V)	$T_a = 25^\circ\text{C}$		$T_a = -40 \text{ to } +85^\circ\text{C}$		Unit	Test Conditions		
			Min	Typ	Max	Min			Max	
Maximum clock frequency	f_{max}	2.0	—	—	5	—	4	MHz		
		4.5	—	—	25	—	20			
		6.0	—	—	29	—	24			
Propagation delay time	t_{PHL}	2.0	—	—	160	—	200	ns	Clock to Q	
		4.5	—	14	32	—	40			
		6.0	—	—	27	—	34			
	t_{PLH}	2.0	—	—	160	—	200	ns		
		4.5	—	15	32	—	40			
		6.0	—	—	27	—	34			
	t_{PHL}	2.0	—	—	175	—	220	ns	Clear to Q	
		4.5	—	17	35	—	44			
		6.0	—	—	30	—	37			
Setup time	t_{su}	2.0	100	—	—	125	—	ns	A, B to Clock	
		4.5	20	1	—	25	—			
		6.0	17	—	—	21	—			
Hold time	t_h	2.0	5	—	—	5	—	ns	Clock to A, B	
		4.5	5	0	—	5	—			
		6.0	5	—	—	5	—			
Removal time	t_{rem}	2.0	5	—	—	5	—	ns	Clear to Clock	
		4.5	5	0	—	5	—			
		6.0	5	—	—	5	—			
Pulse width	t_w	2.0	80	—	—	100	—	ns	Clock	
		4.5	16	8	—	20	—			
		6.0	14	—	—	17	—			
			2.0	80	—	—	100	—	ns	Clear
			4.5	16	5	—	20	—		
			6.0	14	—	—	17	—		
Output rise/fall time	t_{TLH}	2.0	—	—	75	—	95	ns		
	t_{THL}	4.5	—	5	15	—	19			
	t_{THL}	6.0	—	—	13	—	16			
Input capacitance	C_{in}	—	—	5	10	—	10	pF		

勝特力材料 886-3-5753170
 勝特力电子(上海) 86-21-54151736
 勝特力电子(深圳) 86-755-83298787
[Http://www.100y.com.tw](http://www.100y.com.tw)

HITACHI

Unit: mm

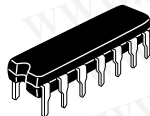
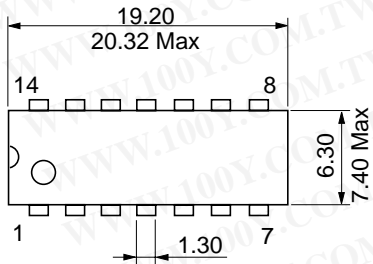

勝特力材料 886-3-5753170
 勝特力电子(上海) 86-21-54151736
 勝特力电子(深圳) 86-755-83298787
[Http://www.100y.com.tw](http://www.100y.com.tw)

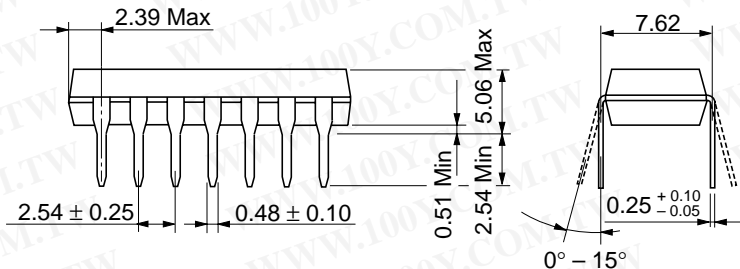

Hitachi Code	DP-14
JEDEC	Conforms
EIAJ	Conforms
Weight (reference value)	0.97 g

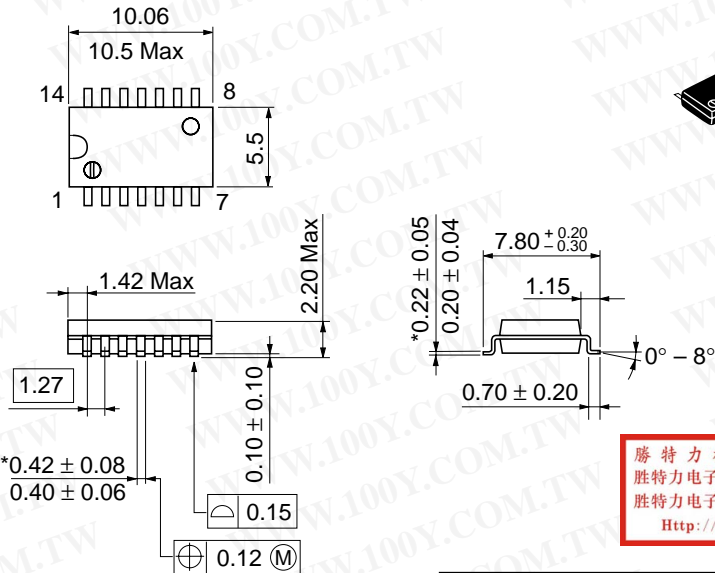

*Dimension including the plating thickness
 Base material dimension

Hitachi Code	FP-14DA
JEDEC	—
EIAJ	Conforms
Weight (reference value)	0.23 g

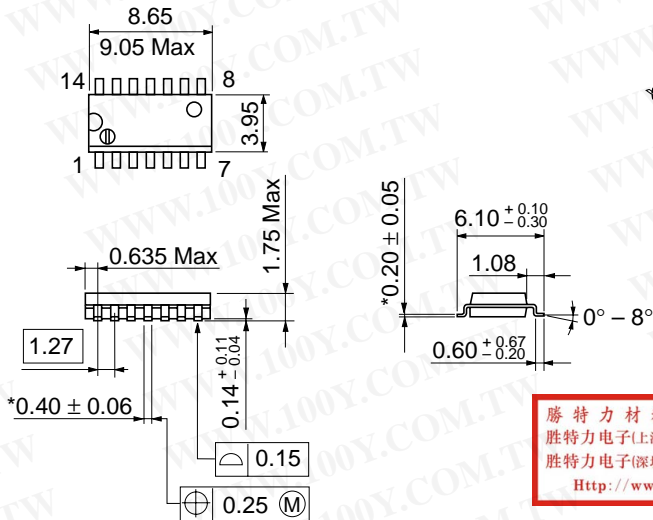

勝特力材料 886-3-5753170
 勝特力电子(上海) 86-21-54151736
 勝特力电子(深圳) 86-755-83298787
[Http://www.100y.com.tw](http://www.100y.com.tw)

Hitachi Code	FP-14DN
JEDEC	Conforms
EIAJ	Conforms
Weight (reference value)	0.13 g

Cautions

1. Hitachi neither warrants nor grants licenses of any rights of Hitachi's or any third party's patent, copyright, trademark, or other intellectual property rights for information contained in this document. Hitachi bears no responsibility for problems that may arise with third party's rights, including intellectual property rights, in connection with use of the information contained in this document.
2. Products and product specifications may be subject to change without notice. Confirm that you have received the latest product standards or specifications before final design, purchase or use.
3. Hitachi makes every attempt to ensure that its products are of high quality and reliability. However, contact Hitachi's sales office before using the product in an application that demands especially high quality and reliability or where its failure or malfunction may directly threaten human life or cause risk of bodily injury, such as aerospace, aeronautics, nuclear power, combustion control, transportation, traffic, safety equipment or medical equipment for life support.
4. Design your application so that the product is used within the ranges guaranteed by Hitachi particularly for maximum rating, operating supply voltage range, heat radiation characteristics, installation conditions and other characteristics. Hitachi bears no responsibility for failure or damage when used beyond the guaranteed ranges. Even within the guaranteed ranges, consider normally foreseeable failure rates or failure modes in semiconductor devices and employ systemic measures such as fail-safes, so that the equipment incorporating Hitachi product does not cause bodily injury, fire or other consequential damage due to operation of the Hitachi product.
5. This product is not designed to be radiation resistant.
6. No one is permitted to reproduce or duplicate, in any form, the whole or part of this document without written approval from Hitachi.
7. Contact Hitachi's sales office for any questions regarding this document or Hitachi semiconductor products.

HITACHI

Hitachi, Ltd.

Semiconductor & Integrated Circuits.
Nippon Bldg., 2-6-2, Ohte-machi, Chiyoda-ku, Tokyo 100-0004, Japan
Tel: Tokyo (03) 3270-2111 Fax: (03) 3270-5109

URL North America : <http://semiconductor.hitachi.com/>
Europe : <http://www.hitachi-eu.com/hel/ecg>
Asia (Singapore) : <http://www.has.hitachi.com.sg/grp3/sicd/index.htm>
Asia (Taiwan) : http://www.hitachi.com.tw/E/Product/SICD_Frame.htm
Asia (HongKong) : <http://www.hitachi.com.hk/eng/bo/grp3/index.htm>
Japan : <http://www.hitachi.co.jp/Sicd/indx.htm>

For further information write to:

Hitachi Semiconductor (America) Inc. 179 East Tasman Drive, San Jose, CA 95134 Tel: <1> (408) 433-1990 Fax: <1>(408) 433-0223	Hitachi Europe GmbH Electronic components Group Dornacher Straße 3 D-85622 Feldkirchen, Munich Germany Tel: <49> (89) 9 9180-0 Fax: <49> (89) 9 29 30 00
Hitachi Asia Pte. Ltd. 16 Collyer Quay #20-00 Hitachi Tower Singapore 049318 Tel: 535-2100 Fax: 535-1533	Hitachi Asia Ltd. Taipei Branch Office 3F, Hung Kuo Building, No.167, Tun-Hwa North Road, Taipei (105) Tel: <886> (2) 2718-3666 Fax: <886> (2) 2718-8180
Hitachi Asia (Hong Kong) Ltd. Group III (Electronic Components) 7/F., North Tower, World Finance Centre, Harbour City, Canton Road, Tsim Sha Tsui, Kowloon, Hong Kong Tel: <852> (2) 735 9218 Fax: <852> (2) 730 0281 Telex: 40815 HITEC HX	Hitachi Europe Ltd. Electronic Components Group. Whitebrook Park Lower Cookham Road Maidenhead Berkshire SL6 8YA, United Kingdom Tel: <44> (1628) 585000 Fax: <44> (1628) 778322

勝特力材料 886-3-5753170
勝特力电子(上海) 86-21-54151736
勝特力电子(深圳) 86-755-83298787
[Http://www.100y.com.tw](http://www.100y.com.tw)

Copyright ' Hitachi, Ltd., 1999. All rights reserved. Printed in Japan.

HITACHI