



勝特力材料 886-3-5753170
勝特力电子(上海) 86-21-54151736
勝特力电子(深圳) 86-755-83298787
[Http://www.100y.com.tw](http://www.100y.com.tw)

CATALOG

Quality Tools for the electronics Industry

HAKKO FX-951 ESD SAFE
SOLDERING STATION



- Soldering
- Rework
- Desoldering
- Smoke Absorber
- Static Control
- Heating Gun
- Glue Gun
- Other Tools

勝特力材料 886-3-5753170
勝特力电子(上海) 86-21-54151736
勝特力电子(深圳) 86-755-83298787
[Http://www.100y.com.tw](http://www.100y.com.tw)

**“To deliver excitement to our customers”
This statement reflects Hakko’s ideal.**

In creating products, we not only make products as a manufacturer, but also add hospitality, in order to express our ideal of delivering excitement to our customers. The ideal is also our basis for continuing to meet the challenges of creating new possibilities.

Hakko’s products offer the best soldering for any component, in any environment, from the latest electronics to hobbies and crafts. Each genre is expanding without limits as the 21st century technology continues to advance and the world becomes increasingly borderless.

We give form to ideas beyond the norm by facing the user’s true needs with a welcoming feeling. Hakko confidently introduces soldering irons and related equipment with world class quality, starting with the new products designed in Blue & Yellow.



The Blue which inherited from the HAKKO corporate blue, this expresses both the tradition that we continue and the beauty of the global environment.

The Yellow which is resonating with HAKKO corporate blue, this yellow express the imagination of every single employee and our team spirit.

HAKKO BLUE & YELLOW

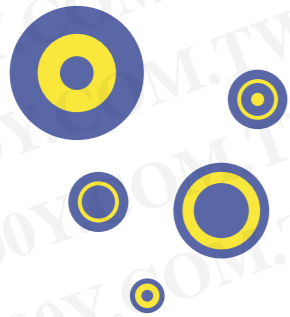

FRIENDLY innovation

Not only has Hakko been approved by ISO 9001 & 14000, but we are also conducting our own campaigns. We are involved in improving quality through 3 “friendlies.”

“Hakko is friendly to customers”

We always strive to take on the perspective of our customers and think outside the normal frameworks to deliver products that amaze and excite customers.

“Hakko is friendly to society”

We take the environment into careful consideration when creating the products so that people and nature co-exist. In addition, each individual carries out activities that are valuable to the society.

“Hakko employees are friendly to each other”

Teamwork is very important in order to deliver the products that excite the customers. Creative power stems from the relations among the employees as well as between the Hakko international groups.



Blue meets yellow GREEN PROJECT

Hakko, as a specialized manufacturer of soldering irons, has established the Green Project.

We promote the development of products that are friendly to the environment (e.g., conforming to the EU RoHS directives, etc.), starting with products compatible with lead-free soldering.

We rapidly respond to the latest needs of our customers. Our lineup of products, including new products designed in Blue & Yellow and products compatible with lead-free soldering (e.g., soldering irons for various purposes, desoldering stations, etc.), could only be offered by a specialized manufacturer like Hakko.

Furthermore, our Green Project not only eliminates the hazardous materials from the products, but also aims to expand our activities so that our business is friendly to the people and the society. Hakko is always moving forward with our eyes on the future to deliver products that excite customers throughout the world.

勝特力材料 886-3-5753170
勝特力电子(上海) 86-21-54151736
勝特力电子(深圳) 86-755-83298787
[Http://www.100y.com.tw](http://www.100y.com.tw)



Our company has been certified under ISO 9001 (JIS Z 9901), the international quality system standards. We are also certified under ISO 14001 (JIS Q 14001) and are actively involved in preserving the global environment.

Quality Tools for the electronics Industry

HAKKO 490

SMOKE CLEANER



- Compact and noise free, making it perfect for low-noise environments and desktop use.
- Use compressed air - no power supply is necessary.

Compatible Soldering Iron



HAKKO 936*
(Iron: 907/908)



HAKKO 937*
(Iron: 907/908)



HAKKO 928*
(Iron: 900M/L)



HAKKO 931



HAKKO 933/934



HAKKO DASH



HAKKO MACH-I



HAKKO 701*
(Iron: 907/908)



HAKKO 702B*
(Iron: 907/908)

*900S soldering iron and desoldering gun are not compatible with HAKKO 490.

Set Up

(900M/L, 907, 908, DASH)

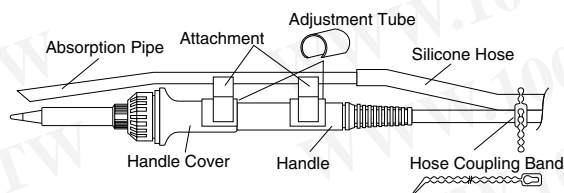

(902, 904, 933, 934, MACH-I)

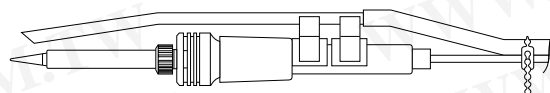

Specifications

Model No.	490
Height	200mm
Diameter	120mm
Weight	1.5kg
Noise Level	39db
Working Pressure	4~7kgf/cm ² (392~686kPa)
Air Consumption	40ℓ/min (5kgf/cm ²)
Suction Flow	2.3ℓ/min (5kgf/cm ²)

Packing List

Model Name	Contents
HAKKO 490	Unit 1
	Absorption pipe set (No.C1125) 1

*A second soldering iron can be attached to HAKKO 490 by purchasing an additional Absorption pipe set.

勝特力材料 886-3-5753170
 勝特力电子(上海) 86-21-54151736
 勝特力电子(深圳) 86-755-83298787
[Http://www.100y.com.tw](http://www.100y.com.tw)

HAKKO 494

SMOKE ABSORBER



- Compact, light weight design.
- Convenient operation-easy to install flexible ducts permit quick and simple system adaption to longer or relocated production lines.
- Highly efficient operation-fumes and flux are absorbed at their source and trapped by a double filter system.
- One HAKKO 494 system handles Max. 10 soldering irons.

Examples of Installation

Parallel piping joint (No.B1246) permits a variety of piping layouts to be used.

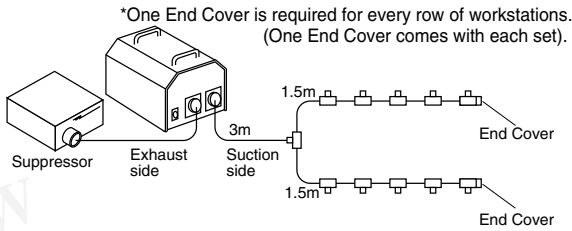

Specifications

Model No.	494	
Frequency	50Hz	60Hz
Power Consumption	150W	200W
Static Pressure	2.3KPa (240mm/Aq)	3.2KPa (325mm/Aq)
Absorption Capacity	1.56m ³ /min.	1.82m ³ /min.
Length of Duct (Inlet)	< 20m	
Length of Duct (Outlet)	< 5m	
Dimensions (w/o duct)	322(W) x 300(H) x 386(D)mm	
Weight (w/o cord & duct)	18kg	

*Above Measurement Value: Unit only

Optional Attachments

Part No.	Name/Description	Accessories
C1029	Absorption Pipe Set A for HAKKO DASH, 900M, 900L	
C1030	Absorption Pipe Set B for HAKKO MACH-II(920-922)	
C1031	Absorption Pipe Set C for HAKKO MACH-II(918)	Absorption pipe1
C1033	Absorption Pipe Set E for HAKKO MG(except 150W)	Silicone hose 1m1 Hose coupling band5
C1034	Absorption Pipe Set F for HAKKO 455	Metal fitting for absorption pipe1
C1035	Absorption Pipe Set G for HAKKO 456	
C1086	Absorption Pipe Set H for HAKKO 902, 904	
C1125	Absorption Pipe Set Q for HAKKO 907, 908, 933, 934	Absorption pipe1 Attachment2 Silicone hose 1.5m1 Adjustment tube3 Hose coupling band5

Packing List

Model Name	Contents
HAKKO 494	Unit1
	Absorption pipe set1
	Duct 3m1
	Filter case1
	Filter cap1
	End cover1
	Nylon strap2
	Main filter5
	Exhaust duct 5m1
	Pre-filter5
	Suppressor1
	Inlet socket for smoke absorber1

When ordering HAKKO 494, please specify the model number of soldering station/iron and q'ty to be used for additional parts arrangement.

Duct Set

Part No.	Part Name	Contents
C1028	Duct Set	Filter cap1
		Pre-filter5
		Filter case1
		Duct 1.5m1 Nylon strap2

勝特力材料 886-3-5753170
 勝特力电子(上海) 86-21-54151736
 勝特力电子(深圳) 86-755-83298787
[Http://www.100y.com.tw](http://www.100y.com.tw)

HAKKO 493 ESD SAFE



- Fully-adjustable, low-noise, high performance fan.
- Use the filter made by joining specific urethan foam with refined activated carbon having a high absorbing performance.
- The entire unit is processed with a non sloughing static dissipative, conductive material.



Specifications

Model No.	493	
Frequency	50Hz	60Hz
Power Consumption	16W	14W
Absorption Capacity (w/filter)	0.93m ³ /min.	1.07m ³ /min.
Accessories	Filter (3 pcs)	
Dimensions	220(W) x 270(H) x 168(D)mm	
Weight (w/o cord)	1.5kg	

Optional Attachments

Part No.	Name/Description
C1023	Arm stand/1.8kg

Replacement Parts

Part No.	Name/Description
A1001	Filter set (5 pcs)

Activated-Carbon Filter

Size	130(W) x 130(H) x 10(D)mm
Amount of Activated-Carbon per one filter	7g
Max.Absorbing weight of noxious components per one filter	2g

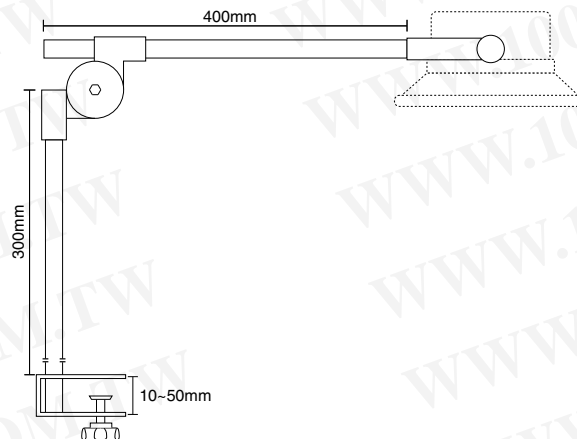

勝特力材料 886-3-5753170
 勝特力电子(上海) 86-21-54151736
 勝特力电子(深圳) 86-755-83298787
[Http://www.100y.com.tw](http://www.100y.com.tw)

HAKKO 443

STATIC ELIMINATOR



- The compact, light weight, and upright design is well suited for use on a desktop, in the production line, and various other applications.
- Utilization of AC corona discharge provides for a good balance of positively charged ion generation and faster neutralization time that changes little over time.
- The airflow direction can be raised and lowered.
- A function for adjusting the airflow rate is provided.

Neutralization time (in sec.) from 1,000V to 10V

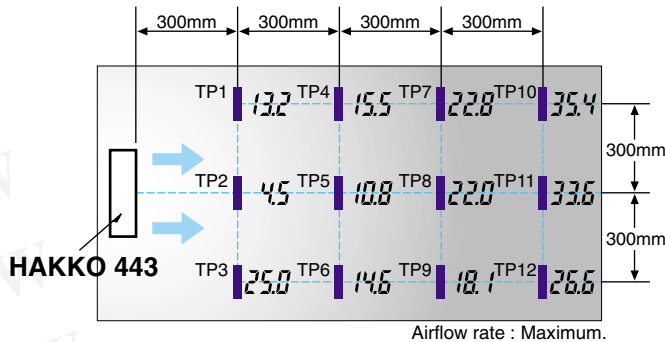

*Method of measurement is in accordance with ANSI-EOS/ESD-S3.1-1991.
*Above data are for reference.

Specifications

Model No.	443
Power Consumption	10W
Output Voltage	3.5 kV AC
Ion Balance	Factory adjusted to within $\pm 10V$ (at 600mm from the front panel)
Air Flow	1.2 to 2.4m ³ /min (variable)
Noize	40 db (A)
Ozone Production	0.01 ppm or less (at a point 150mm from the outlet and aligned with the center of the outlet)
Maximum Allowable Ambient Temperature	50°C
Filter	Pre-Filter level
Dimensions	140(W) x 190(H) x 83(D)mm
Weight (w/o cord)	1.4kg

Packing List

Model Name	Contents
HAKKO 443	Unit1
	Cotton swabs (cleaning for electrodes)1

Optional Attachment

Part No.	Name/Description
C1023	Arm stand/1.8kg



勝特力材料 886-3-5753170
 勝特力电子(上海) 86-21-54151736
 勝特力电子(深圳) 86-755-83298787
[Http://www.100y.com.tw](http://www.100y.com.tw)

HAKKO 430

STATIC LEVEL METER



- Three modes for measuring electric potential:
 - (1) Momentary value of static electric potential.
 - (2) Peak value of static electric potential.
 - (3) AC potential.
- Measurement of ion balance in 1-V intervals.
- High sensitivity and high precision.
- Simple adjustment of measurement distance.
- Pocket size: compact and light weight.

Specifications

Model No.	430	
Electric Potential Measurement	Range	0 to $\pm 19.99\text{kV}$
	Resolution	10V
	Distance	50mm (between detector and object being measured)
	Output	1V for 10kV display, output impedance 100
	Measurement Distance Adjustment	Red LED beam (find distance where light spot is in focus)
Ion Balance Measurement	Range	0 to $\pm 1,999\text{V}$
	Resolution	1V
	Distance	Any (when plate is attached)
	Output	1V for 1kV display, output impedance 100
Measurement Precision	$\pm 5\%$ of reading ± 2 digits (in range from - 10kV to +10kV)	
Display	Over Range	# □ □ □
	Battery Alarm	AC (DC) blinks
	Polarity	Indicates negative (-) polarity only
Power Supply	One 1.5V Alkaline Battery "AA" (provide approximately 10 hours of continuous use)	
Operating Environment	0 to 40°C, 20 to 90% RH, no dew formation	
Dimensions	106(W) x 23(H) x 66(D)mm	
Weight (w/battery)	120g	

Packing List

Model Name	Contents
HAKKO 430	Unit1
	Alkaline battery "AA"1
	Plate for measuring (Ion balance)1
	Grounding wire with screw and nut1
	Monitor cord1

勝特力材料 886-3-5753170
 勝特力电子(上海) 86-21-54151736
 勝特力电子(深圳) 86-755-83298787
[Http://www.100y.com.tw](http://www.100y.com.tw)

HAKKO 442B

WRIST STRAP



- Comfortable and light weight.
- Standard ground termination is alligator clip & w/banana plug.
- With adjustable wrist band.
- Available in blue color.

勝特力材料 886-3-5753170
 勝特力电子(上海) 86-21-54151736
 勝特力电子(深圳) 86-755-83298787
[Http://www.100y.com.tw](http://www.100y.com.tw)

Specifications

Part No.	442B-01	442B-02
Color	Blue	
Grounding Wire	1.5m	2.5m

Replacement Parts

Part No.	Name/Description
B2760	Strap
B2758	Grounding wire/1.5m
B2759	Grounding wire/2.5m

Packing List

Model Name	Contents
HAKKO 442B	Wrist band1
	Grounding wire1
	Cord helper1

How To Use The Cord Helper

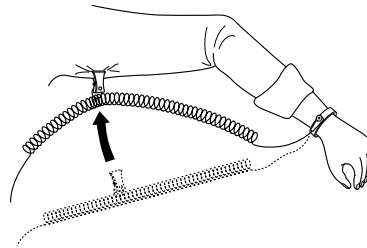

HAKKO 496

WRIST STRAP



- Comfortable and light weight.
- Available in blue, wine and green color.
- 'Velcro' & 'Snap' help quick and easy adjusting.
- Standard ground termination is alligator clip.

Specifications

Part No.	496B	496R	496G
Color	Blue	Wine	Green
Grounding Wire	2m		

Replacement Parts

Part Name	Name/Description
496-1B	Wrist band <Blue>
496-1R	Wrist band <Wine>
496-1G	Wrist band <Green>
496-2B	Grounding wire <Blue>
496-2R	Grounding wire <Wine>
496-2G	Grounding wire <Green>

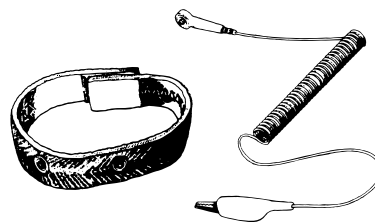
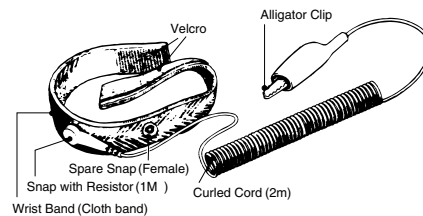

HAKO 498

SYSTEM TESTER



- Can be used anywhere to quickly and easily to check a variety of grounding systems.
- Ensures employee's safety.
- Eliminates product defects caused by static electricity.



Quickly and simply checks

Wrist straps and grounding wires.

The contact resistance between the wrist strap and the skin.

Operation

Simply connect the grounding wire and press the pad.

If the grounding system is safe, the green 'GOOD' lamp will light up and an audible signal will be heard.

Specifications

Model No.	498	
Power Supply	9V Battery	
Grounding Wire	2.5m	
Operating Environment	0 to 40°C, 20 to 90%RH, no dew formation	
LED Indication	Calibration Resistance	Buzzer
LOW (Red)	R<800K	OFF
GOOD (Green)	800K ≤R≤9M	ON
HIGH (Red)	R>9M	OFF

勝特力材料 886-3-5753170
 勝特力电子(上海) 86-21-54151736
 勝特力电子(深圳) 86-755-83298787
[Http://www.100y.com.tw](http://www.100y.com.tw)

HAKKO HEATING GUN



No. 880B/881



No. 882

- Ideal for use in a variety of heating operations including drying paint, processing shrink films and shrink tubing, drying resin putty for sheet metal, repairing automobile urethane bumpers and applying long-length floor materials or vinyl moldings.
- Powerful heating for a wide range of work.
- Light weight, ergonomic design for easier handling and simpler operation.

勝特力材料 886-3-5753170
 勝特力电子(上海) 86-21-54151736
 勝特力电子(深圳) 86-755-83298787
[Http://www.100y.com.tw](http://www.100y.com.tw)

Specifications

Model No.	880B	881	882
Power Consumption	800W	1000W	
Maximum Temperature*	400°C	450°C	
Temp. Control Function	---	---	Room Temp. ~450°C
Air Velocity	330m/min.	360m/min.	
Air Flow	0.18m³/min.	0.2m³/min.	
Dimensions	245(W) x 185(H) x 70(D)mm		285(W) x 185(H) x 70(D)mm
Weight (w/o cord)	550g		700g

*Max. Temp. is approximate one which measured at the point 10mm from the pipe.

Compatibility Chart

The optional attachments that can be used depend on the model. Use the chart below to check for compatibility.

Part No.	Model No.	880B	881	882
A1108				
A1109		○	○	○
A1110		○	○	○
A1111		○	○	○
*A1112			○	○
*A1113		○		
*A1114		○	○	○
B1419		○	○	
B1420				○

○ ... Usable

*Indicate optional attachments that require the A1111 for use.

Optional Parts & Operating Technique

(The temperature of No. 882 is at Temp. Control knob 6.)

No.A1109 Nozzle/Hook Type

Ideal for the circumference heating of shrink tubing, plastic shafting etc.



No.A1110 Nozzle/Spatula Type 62mm

Ideal for heating of large items like shrink film.

	880B	881.882
Temperature	350°C	400°C
Air Velocity	270m/min.	300m/min.

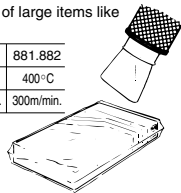

No.A1111 Nozzle Holder

Attach this nozzle according to drawing, and use for partial heating.

	880B	881.882
Temperature	450°C	500°C
Air Velocity	580m/min.	630m/min.

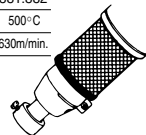

No.A1112 Nozzle

Insert this nozzle into No. A1111. Ideal for repairing carpet etc. where an adhesive agent is used.

	881.882
Temperature	550°C
Air Velocity	780m/min.

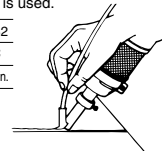

No.A1113 Nozzle/Single ø5

Insert this nozzle into No. A1111. Ideal for partial heating.

	880B
Temperature	550°C
Air Velocity	780m/min.



No.A1114 Nozzle/Spatula Type 20mm

Attach this nozzle on No. A1111. Ideal for adhesion of vinyl chloride sheet etc.

	880B	881.882
Temperature	450°C	500°C
Air Velocity	720m/min.	780m/min.

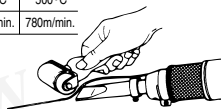

No.B1419 Stand No.B1420 Stand

For vertical operation. Remove original and attach.

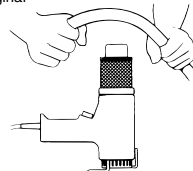

HAKKO MELTER



- Temperature control function enables use of polyamide adhesives that are ideal for use with electronic components.
- Superior thermal recovery makes the unit tough enough to handle several operations in succession.
- Anti-overheat mechanism
–Built-in thermal fuse near the heater, prevent the temperature from rising too high.

Major Applications

When using polyamide adhesives

- Reinforce and insulate soldered parts.
- Fasten capacitors, resistors, etc.
- Fasten jumper wires.
- Perform insulation potting for terminals.
- Fasten the ends of coils.
- Fasten deflecting yokes and variable coils.

When using EVA adhesives

- Glue paper products. (carboard boxes, gift boxes, etc.)
- Fasten wood products.
- Fasten plastics & metals.
- Fasten textiles and shock absorbent packing.
- Reseal products during packaging.

Adhesive Used

This model has been designed for stick adhesives (those hardened into the shape of a stick) only. Be sure to use adhesives recommended by Hakko. (No. 810: UL94V-0 Recognized)

Part No.	810	811	812
Name	Polyamide	EVA	
Packing	1kg		14 pcs
Color	Yellowish-Brown	Milky-White	
Size	ø11.5 x 220mm		
Viscosity	2,300 cps. (2,300mPa·s)	5,800 cps. (5,800mPa·s)	
Open Time*	10 seconds	40 seconds	
Temperature at which adhesive is heat-resistant	100°C	55°C	
Suitability	P.W.B.	○	
	Wood	○	○
	Paper	○	○
	Metal	○	○
	Plastic	○	○
Packing	in aluminum foil bag	in polyethylene bag	in blister pack

Adhesives marked with ○ are more suited for that material than ○.

*Application Period.

Specifications

Model No.	804
Power Consumption	100W
Standard Nozzle	A1083 (ø2.0mm)
Melting Temperature	100-200°C variable
Discharge Capacity	900g/hour
Fusing Temperature	187°C
Dimensions	215(W) x 170(H) x 45(D)mm
Weight (w/o cord)	350g

Replacement Nozzles

Unit : mm

Part No.	Name/Description	Diagram
A1088	Nozzle ø1.0mm	
A1086	Nozzle ø1.5mm	
A1083	Nozzle ø2.0mm	
A1089	Long nozzle ø1.0mm	
A1087	Long nozzle ø1.5mm	
A1084	Long nozzle ø2.0mm	

勝特力材料 886-3-5753170
 勝特力电子(上海) 86-21-54151736
 勝特力电子(深圳) 86-755-83298787
[Http://www.100y.com.tw](http://www.100y.com.tw)

HAKO CUTTING TOOL



- Designed for precision assembly of delicate, complex electronic work.
- Soft-touch grip ensures long and comfortable work.
- Recommend to cut copper & soft lead wires.

勝特力材料 886-3-5753170
 勝特力电子(上海) 86-21-54151736
 勝特力电子(深圳) 86-755-83298787
[Http://www.100y.com.tw](http://www.100y.com.tw)

Specifications

Model No.	Name	Maximum cutting capability for copper wire
106-01	Flush Cut with Safety Clip	1.3mm
106-02	Flush Cut with Angled Blade	1.3mm
106-03	Flush Cut with Small Blade	0.8mm
106-04	For a Front, Flush Cut	1.0mm
106-05	Flush Cut	1.3mm
106-06	Short Nose Pliers	-
106-07	Long Nose Pliers	-
106-08	Bent Nose Pliers	-

Unit : mm

Model No.	A	B	C	D	E
106-01	138	54	13.5	5	20
106-02	135	54	13.5	5	16
106-03	136	54	9.5	4	18
106-04	144	54	14	6	27
106-05	138	54	13.5	5	20
106-06	146	54	13	6	29
106-07	160	54	13	6	40
106-08	152	54	13	4	35

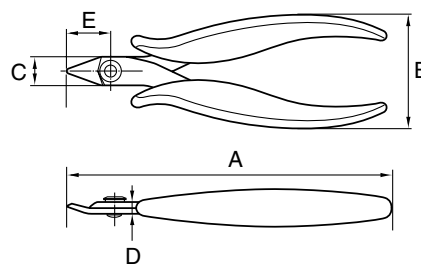

HAKO 392 ESD SAFE

VACUUM PICK-UP



- A built-in diaphragm pump eliminates the need for a separate air supply unit.
- Lifts objects weighting up to 120g.
- Pen, suction pads and air hoses are all made of anti-static materials for greater safety and reduced risk of damage to delicate parts.

勝特力材料 886-3-5753170
 勝特力电子(上海) 86-21-54151736
 勝特力电子(深圳) 86-755-83298787
[Http://www.100y.com.tw](http://www.100y.com.tw)

Easy To Set Up, Easy To Use



1. Place the nozzle or pad on the object to be picked up.
2. Place a finger over the hole in the pen.
 A vacuum is instantly created and the resulting suction at the tip of the pen "holds" the object to the pen.
3. Now raise the pen and the object is lifted along with the pen.

Specifications

Model No.	392
Power Consumption	5W
Pump	Diaphragm Type
Maximum Pressure	37.3KPa (280mmHg)
Accessories	Bent Nozzle x 2 (Inner Dia. 0.4mm & 1.1mm) Pad x 2 (Outer Dia. 3mm & 7mm)
Dimensions	Station : 132(W) x 83(H) x 170(D)mm Pen : 123(L) x 10 (outer dia.)mm Air Hose: 1100(L) x 6 (outer dia.)mm
Weight (w/o cord)	Station : 1.65kg Pen : 25g

Vacuum Pick-up Performance

Nozzle/Pad	Maximum Item Weight	Applications
Bent Nozzle <0.4mm>	0.6g	Chip resistors and tiny components
Bent Nozzle <1.1mm> + Pad <3mm>	2g	Small ICs (8~40 pins)
Bent Nozzle <1.1mm> + Pad <7mm>	20g	ICs (40 pins or greater)
Bent Nozzle <1.1mm> + Pad <7mm>	120g	Large electronic components, etc

HAKKO 394

VACUUM PICK-UP



- A built-in very small, but powerful pump eliminates the needs of power cord and air tube.
- Easy to handle for continuous pickup.
- Anti-static material are used.

勝特力材料 886-3-5753170
 勝特力电子(上海) 86-21-54151736
 勝特力电子(深圳) 86-755-83298787
[Http://www.100y.com.tw](http://www.100y.com.tw)

Service Life of Battery

Pickup repetition limit*1	Continuous pickup time*2
Approx. 30,000 pickup times (With alkaline batteries)	Approx. 15 hours

*1. 26mm x 26mm QFP is pickup for 2 seconds using a 10 mm dia. pad and then released for 1 second. This cycle is repeated continuously until the QFP is no longer picked up.

*2. This is the time period from the moment 26mm x 26mm QFP starts being pickup using a 10 mm dia. pad to the moment the QFP drops.



Applicable for Chip Components
(With A1164 Bent Nozzle)

Specifications

Model No.	394
Power Supply	Alkaline Battery "AAA" x 2
Dimensions	130(L) x 22(W) x 29(H)mm
Weight (w/o batteries)	43g

Replacement Parts

Part No.	Name/Description
A1164	Bent nozzle 0.4mm
A1165	Bent nozzle 1.1mm with stopper
A1198	Bent nozzle 0.26mm
A1486	Straight Nozzle 1.1mm with stopper
A1166	Pad 3mm
A1312	Pad 5mm
A1167	Pad 7mm
A1311	Pad 10mm

Packing List

Model Name	Contents
HAKKO 394	Unit1
	Bent nozzle 1.1mm with stopper (No.A1165)1
	Pad 5mm (No.A1312)1
	Pad 10mm (No.A1311)1
	Alkaline battery "AAA"2

Pickup Power

Part No.	Name/Description	Pickup Performance
A1166	Pad 3mm	6 gf
A1312	Pad 5mm	40 gf
A1167	Pad 7mm	80 gf
A1311	Pad 10mm	120 gf

*The max. pickup performance shown above slightly differs depending on the surface of the object.

HAKKO 153·154

LEAD FORMER



Specifications

Part No.	153-1	154-1
Forming Size	5.6mm Pitch	5mm Pitch
Max. Diameter of Lead*	ø0.8mm	ø0.5mm
Compatible Taping Dimension	Outer Width of Tape	Max. 85mm
	Pitch	5mm
Dimensions	125(W) x 130(H) x 110(D)mm	
Weight	2kg	

CAUTION *For annealed copper lead only.

Cutting and forming for tape-type axial components

- Easy to use—simply set the taped components in place and turn the handle. Ideal for processing tape-type components.
- Improved, longer-life cutting blade for a clean, smooth cut.
- Sealed bearings for longer service life and greater durability and efficiency.
- Can be used for forming and cutting, forming only, or cutting only.

HAKKO 153

· Cutting & Forming

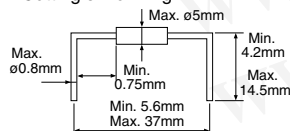

· Forming only

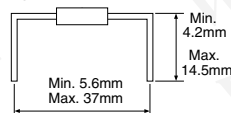

· Cutting only



HAKKO 154

· Cutting & Forming

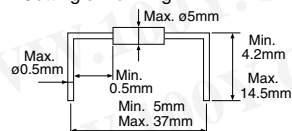

· Forming only

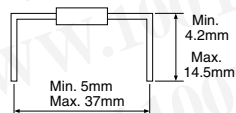

· Cutting only

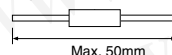

HAKKO 155

LEAD CUTTER



Specifications

Part No.	155-1	155-2
① Max. Diameter of Lead Wire	ø0.8mm	
② Max. Processing Part Size	ø12.5mm~25mm	ø15mm~25mm
③ Feed Hole Pitch	12.7mm	15mm
④ Lead Pitch	*2.5mm, 5.0mm	5.0mm
⑤ Min. Processing Size	1.5mm from taping end	2.0mm from part end
Dimensions	125(W) x 110(H) x 140(D)mm	
Weight	1.7kg	

*When processing a part with a lead pitch of 2.5mm, be sure to adjust the cutting wheel. Parts with a pitch of 2.5mm can be processed only on the No.155-1.

Cutting for tape-type radial components

- Easy to use—simply set the taped components in place and turn the handle. The super-sharp, high quality cutting blade allows you to cut all types of tape-type radial parts, including resistors, capacitors, transistors, etc. cleanly and smoothly. Continuous operation ensures faster, more efficient processing.
- Sealed bearings make it long-lasting, durable and efficient.
- The compact design allows you to place it virtually anywhere.

· Cutting only

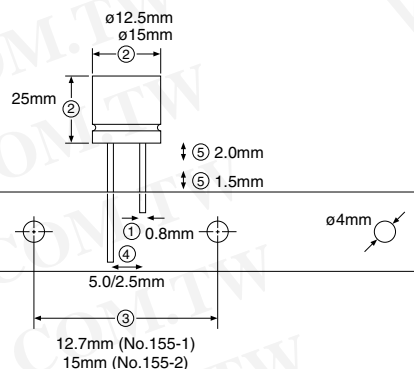

HAKKO 152B

MOTOR DRIVE



*Combination with HAKKO 153.
*The HAKKO 153 is not included with the HAKKO 152B.

Automatic cutting and forming

- Constant-torque drive ensures uniform processing quality.
- Processes up to 36,000 pieces per hour when used with the HAKKO 153.154, up to 18,000 pieces per hour with the HAKKO 155.
- Speed control knob permits adjustment of the processing speed.

Specifications

Model No.	152B	
Rotary	28rpm (50Hz), 34rpm (60Hz)	
Max. Processing Capacity	36,000 pcs/hr (w/HAKKO 153. 154)	18,000 pcs/hr (w/HAKKO 155)
Dimensions	430(W) x 150(H) x 140(D)mm	
Weight (w/o cord)	5.6kg	

勝特力材料 886-3-5753170
 勝特力电子(上海) 86-21-54151736
 勝特力电子(深圳) 86-755-83298787
[Http://www.100y.com.tw](http://www.100y.com.tw)

HAKKO DIPLINER

LEAD STRAIGHTENER



- Low-cost, high-performance tool for reforming IC and LSI leads.
- Speeds IC and LSI insertion.
- No more broken leads during IC and LSI insertion or transportation.
- Simply insert the IC case into the Dipliner chute, and the leads are protected right through circuit board insertion.
- Adjustable lead former fits all types, sizes and makes of ICs and LSIs.
- Simple mechanism for maintenance-free operation.

Specifications

Model No.	Width of IC	Number of IC Leads
FT100	7.5mm	8,14,16,18,20
FT150	10mm	22
FT200	15mm	24,28,40,42
FT300	19mm	64



Hakko Global Network



Global and Niche: The Hakko brand is much loved in more than 50 countries worldwide.

We have grown into a global brand. Currently, Hakko soldering irons and related equipment are desired in more than 50 countries in overseas markets. We have local corporations and sales representatives in various regions worldwide, and continue to expand our global network. Again, we believe that creative power stems from connections between the Hakko international groups. Hakko promises to fulfill our customers' needs with our global network of friendly relationships.

勝特力材料 886-3-5753170
勝特力电子(上海) 86-21-54151736
勝特力电子(深圳) 86-755-83298787
[Http://www.100y.com.tw](http://www.100y.com.tw)



<http://www.hakko.com>

Please access to the following address for the other Sales affiliates.



CATALOG

Quality Tools for the electronics Industry

勝特力材料 886-3-5753170
勝特力电子(上海) 86-21-54151736
勝特力电子(深圳) 86-755-83298787
[Http://www.100y.com.tw](http://www.100y.com.tw)

**HAKKO CORPORATION**
OVERSEAS AFFILIATES

U.S.A.
AMERICAN HAKKO PRODUCTS, INC.
28920 N. AVE. WILLIAMS VALENCIA, CA 91355, U.S.A.
TEL: (661) 294-0090 FAX: (661) 294-0096
Toll Free (800)88-HAKKO
<http://www.hakkousa.com>

HEAD OFFICE
4-5, SHIOKUSA 2-CHOME, NANIWA-KU, OSAKA, 556-0024 JAPAN
TEL:+81-6-6561-3225 FAX:+81-6-6561-8466
<http://www.hakko.com> E-mail:sales@hakko.com

HONG KONG
HAKKO DEVELOPMENT CO., LTD.
ROOM 1504, EASTERN HARBOUR CENTRE,
28 HOI CHAK STREET, QUARRY BAY, HONG KONG.
TEL: 2811-5588 FAX: 2590-0217
<http://www.hakko.com.hk>
E-mail:info@hakko.com.hk

SINGAPORE
HAKKO PRODUCTS PTE., LTD.
1, GENTING LINK #02-04, PERFECT INDUSTRIAL
BUILDING, SINGAPORE 349518
TEL: 6748-2277 FAX: 6744-0033
<http://www.hakko.com.sg>
E-mail:sales@hakko.com.sg

Please access to the following address for the other Sales affiliates.
<http://www.hakko.com>

Specifications and design are subject to change without notice.
Copyright HAKKO Corporation.All right reserved.