

- **Single Chip With Easy Interface Between UART and Serial-Port Connector of IBM™ PC/AT and Compatibles**
- **Meet or Exceed the Requirements of TIA/EIA-232-F and ITU v.28 Standards**
- **Designed to Support Data Rates up to 120 kbit/s**
- **Pinout Compatible With SN75C185 and SN75185**

GD65232, GD75232 . . . DB, DW, N, OR PW PACKAGE (TOP VIEW)

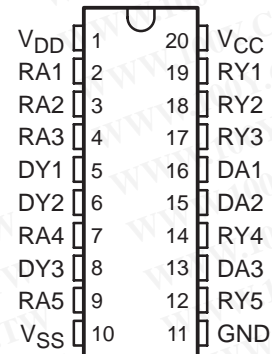

description/ordering information

The GD65232 and GD75232 combine three drivers and five receivers from the Texas Instruments trade-standard SN75188 and SN75189 bipolar quadruple drivers and receivers, respectively. The pinout matches the flow-through design of the SN75C185 to decrease the part count, reduce the board space required, and allow easy interconnection of the UART and serial-port connector of an IBM™ PC/AT and compatibles. The bipolar circuits and processing of the GD65232 and GD75232 provide a rugged, low-cost solution for this function at the expense of quiescent power and external passive components relative to the SN75C185.

The GD65232 and GD75232 comply with the requirements of the TIA/EIA-232-F and ITU (formerly CCITT) V.28 standards. These standards are for data interchange between a host computer and a peripheral at signaling rates up to 20 kbit/s. The switching speeds of these devices are fast enough to support rates up to 120 kbit/s with lower capacitive loads (shorter cables). Interoperability at the higher signaling rates cannot be expected unless the designer has design control of the cable and the interface circuits at both ends. For interoperability at signaling rates up to 120 kbit/s, use of TIA/EIA-423-B (ITU V.10) and TIA/EIA-422-B (ITU V.11) standards is recommended.

ORDERING INFORMATION

| TA | PACKAGE† | | ORDERABLE PART NUMBER | TOP-SIDE MARKING |
|---------------|--------------|--------------|-----------------------|------------------|
| -40°C to 85°C | PDIP (N) | Tube of 20 | GD65232N | GD65232N |
| | SOIC (DW) | Tube of 25 | GD65232DW | GD65232 |
| | | Reel of 2000 | GD65232DWR | |
| | SSOP (DB) | Reel of 2000 | GD65232DBR | GD65232 |
| TSSOP (PW) | Tube of 70 | GD65232PW | GD65232 | |
| | Reel of 2000 | GD65232PWR | | |
| 0°C to 70°C | PDIP (N) | Tube of 20 | GD75232N | GD75232N |
| | SOIC (DW) | Tube of 25 | GD75232DW | GD75232 |
| | | Reel of 2000 | GD75232DWR | |
| | SSOP (DB) | Reel of 2000 | GD75232DBR | GD75232 |
| TSSOP (PW) | Tube of 70 | GD75232PW | GD75232 | |
| | Reel of 2000 | GD75232PWR | | |

† Package drawings, standard packing quantities, thermal data, symbolization, and PCB design guidelines are available at www.ti.com/sc/package.



Please be aware that an important notice concerning availability, standard warranty, and use in critical applications of Texas Instruments semiconductor products and disclaimers thereto appears at the end of this data sheet.

IBM is a trademark of International Business Machines Corporation.

PRODUCTION DATA information is current as of publication date. Products conform to specifications per the terms of Texas Instruments standard warranty. Production processing does not necessarily include testing of all parameters.



POST OFFICE BOX 655303 • DALLAS, TEXAS 75265

Copyright © 2004, Texas Instruments Incorporated

GD65232, GD75232 MULTIPLE RS-232 DRIVERS AND RECEIVERS

SLLS206J – MAY 1995 – REVISED NOVEMBER 2004

勝特力材料 886-3-5753170
 勝特力电子(上海) 86-21-54151736
 勝特力电子(深圳) 86-755-83298787
[Http://www.100y.com.tw](http://www.100y.com.tw)

logic diagram (positive logic)

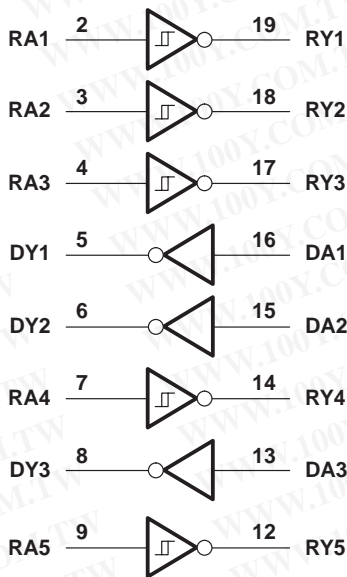

schematic (each driver)

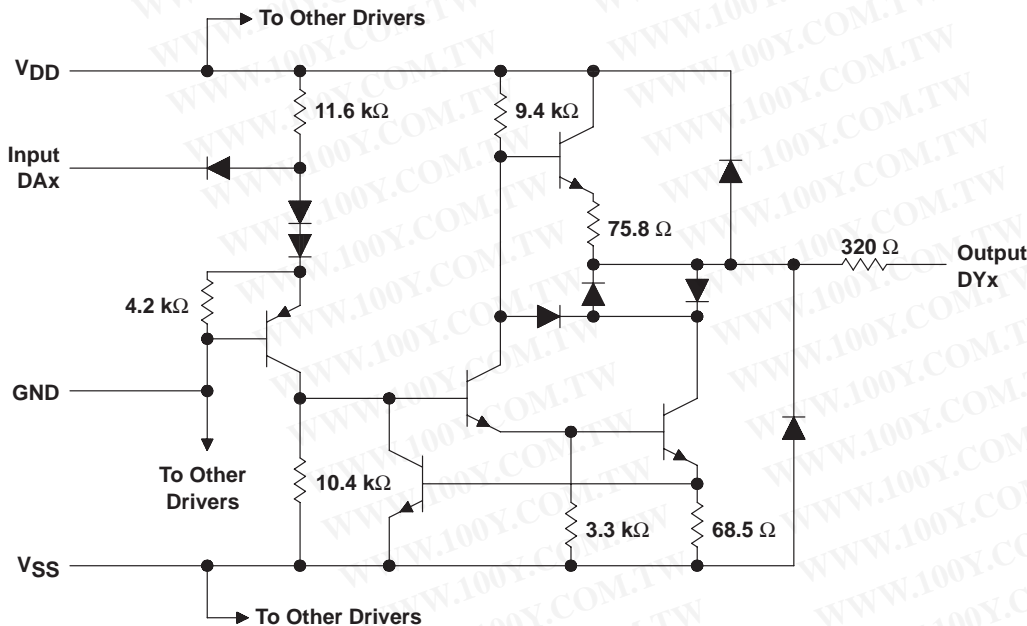

Resistor values shown are nominal.



schematic (each receiver)

勝特力材料 886-3-5753170
 勝特力电子(上海) 86-21-54151736
 勝特力电子(深圳) 86-755-83298787
[Http://www.100y.com.tw](http://www.100y.com.tw)

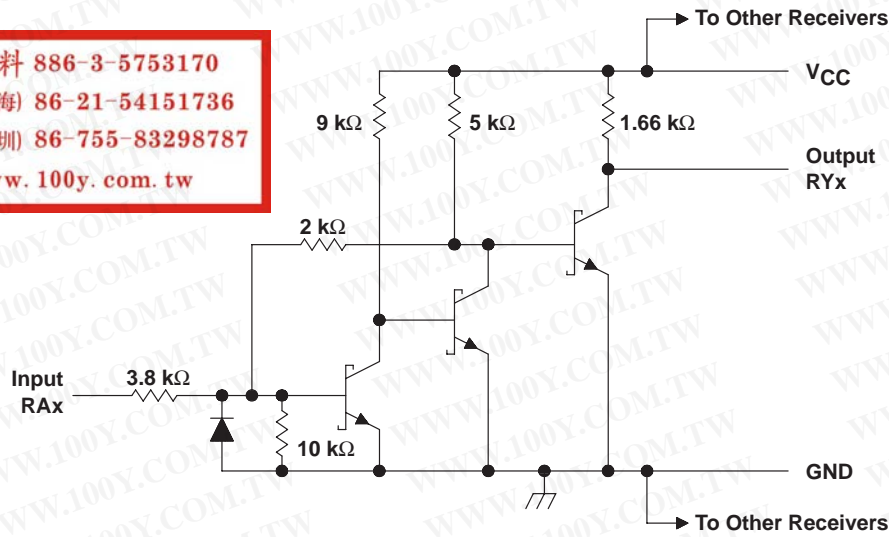

Resistor values shown are nominal.

absolute maximum ratings over operating free-air temperature range (unless otherwise noted)†

| | |
|--|----------------|
| Supply voltage (see Note 1): V_{CC} | 10 V |
| V_{DD} | 15 V |
| V_{SS} | -15 V |
| Input voltage range, V_I : Driver | -15 V to 7 V |
| Receiver | -30 V to 30 V |
| Driver output voltage range, V_O | -15 V to 15 V |
| Receiver low-level output current, I_{OL} | 20 mA |
| Package thermal impedance, θ_{JA} (see Notes 2 and 3): DB package | 70°C/W |
| DW package | 58°C/W |
| N package | 69°C/W |
| PW package | 83°C/W |
| Operating virtual junction temperature, T_J | 150°C |
| Storage temperature range, T_{Stg} | -65°C to 150°C |

† Stresses beyond those listed under "absolute maximum ratings" may cause permanent damage to the device. These are stress ratings only, and functional operation of the device at these or any other conditions beyond those indicated under "recommended operating conditions" is not implied. Exposure to absolute-maximum-rated conditions for extended periods may affect device reliability.

- NOTES:
- All voltages are with respect to the network ground terminal.
 - Maximum power dissipation is a function of $T_J(max)$, θ_{JA} , and T_A . The maximum allowable power dissipation at any allowable ambient temperature is $P_D = (T_J(max) - T_A) / \theta_{JA}$. Operating at the absolute maximum T_J of 150°C can affect reliability.
 - The package thermal impedance is calculated in accordance with JESD 51-7.

GD65232, GD75232 MULTIPLE RS-232 DRIVERS AND RECEIVERS

SLLS206J – MAY 1995 – REVISED NOVEMBER 2004

recommended operating conditions

| | | MIN | NOM | MAX | UNIT |
|-----------------|--|----------|-----|------|------|
| V _{DD} | Supply voltage (see Note 4) | 7.5 | 9 | 15 | V |
| V _{SS} | Supply voltage (see Note 4) | -7.5 | -9 | -15 | V |
| V _{CC} | Supply voltage (see Note 4) | 4.5 | 5 | 5.5 | V |
| V _{IH} | High-level input voltage (driver only) | 1.9 | | | V |
| V _{IL} | Low-level input voltage (driver only) | | | 0.8 | V |
| I _{OH} | High-level output current | Driver | | -6 | mA |
| | | Receiver | | -0.5 | |
| I _{OL} | Low-level output current | Driver | | 6 | mA |
| | | Receiver | | 16 | |
| T _A | Operating free-air temperature | GD65232 | -40 | 85 | °C |
| | | GD75232 | 0 | 70 | |

NOTE 4: When powering up the GD65232 and GD75232, the following sequence should be used:

1. V_{SS}
2. V_{DD}
3. V_{CC}
4. I/Os

Applying V_{CC} before V_{DD} may allow large currents to flow, causing damage to the device. When powering down the GD65232 and GD75232, the reverse sequence should be used.

supply currents over recommended operating free-air temperature range

| PARAMETER | | TEST CONDITIONS | | MIN | MAX | UNIT | |
|-----------------|-------------------------------------|----------------------|----------|---|---------|------|----|
| I _{DD} | Supply current from V _{DD} | All inputs at 1.9 V, | No load | V _{DD} = 9 V, V _{SS} = -9 V | 15 | mA | |
| | | | | V _{DD} = 12 V, V _{SS} = -12 V | 19 | | |
| | | | | V _{DD} = 15 V, V _{SS} = -15 V | 25 | | |
| | | All inputs at 0.8 V, | No load | V _{DD} = 9 V, V _{SS} = -9 V | 4.5 | | |
| | | | | V _{DD} = 12 V, V _{SS} = -12 V | 5.5 | | |
| | | | | V _{DD} = 15 V, V _{SS} = -15 V | 9 | | |
| I _{SS} | Supply current from V _{SS} | All inputs at 1.9 V, | No load | V _{DD} = 9 V, V _{SS} = -9 V | -15 | mA | |
| | | | | V _{DD} = 12 V, V _{SS} = -12 V | -19 | | |
| | | | | V _{DD} = 15 V, V _{SS} = -15 V | -25 | | |
| | | All inputs at 0.8 V, | No load | V _{DD} = 9 V, V _{SS} = -9 V | -3.2 | | |
| | | | | V _{DD} = 12 V, V _{SS} = -12 V | -3.2 | | |
| | | | | V _{DD} = 15 V, V _{SS} = -15 V | -3.2 | | |
| I _{CC} | Supply current from V _{CC} | All inputs at 5 V, | No load, | V _{CC} = 5 V | GD65232 | 38 | mA |
| | | | | | GD75232 | 30 | |

勝特力材料 886-3-5753170
 勝特力电子(上海) 86-21-54151736
 勝特力电子(深圳) 86-755-83298787
[Http://www.100y.com.tw](http://www.100y.com.tw)



GD65232, GD75232 MULTIPLE RS-232 DRIVERS AND RECEIVERS

SLLS206J – MAY 1995 – REVISED NOVEMBER 2004

DRIVER SECTION

electrical characteristics over recommended operating free-air temperature range, $V_{DD} = 9\text{ V}$, $V_{SS} = -9\text{ V}$, $V_{CC} = 5\text{ V}$ (unless otherwise noted)

| PARAMETER | | TEST CONDITIONS | | | MIN | TYP | MAX | UNIT |
|-------------|--|----------------------------------|------------------------------------|--------------|------|------|-------|---------------|
| V_{OH} | High-level output voltage | $V_{IL} = 0.8\text{ V}$, | $R_L = 3\text{ k}\Omega$, | See Figure 1 | 6 | 7.5 | | V |
| V_{OL} | Low-level output voltage (see Note 5) | $V_{IH} = 1.9\text{ V}$, | $R_L = 3\text{ k}\Omega$, | See Figure 1 | | -7.5 | -6 | V |
| I_{IH} | High-level input current | $V_I = 5\text{ V}$, | | See Figure 2 | | | 10 | μA |
| I_{IL} | Low-level input current | $V_I = 0$, | | See Figure 2 | | | -1.6 | mA |
| $I_{OS(H)}$ | High-level short-circuit output current (see Note 6) | $V_{IL} = 0.8\text{ V}$, | $V_O = 0$, | See Figure 1 | -4.5 | -12 | -19.5 | mA |
| $I_{OS(L)}$ | Low-level short-circuit output current | $V_{IH} = 2\text{ V}$, | $V_O = 0$, | See Figure 1 | 4.5 | 12 | 19.5 | mA |
| r_o | Output resistance (see Note 7) | $V_{CC} = V_{DD} = V_{SS} = 0$, | $V_O = -2\text{ V to } 2\text{ V}$ | | 300 | | | Ω |

- NOTES: 5. The algebraic convention, where the more positive (less negative) limit is designated as maximum, is used in this data sheet for logic levels only (e.g., if -10 V is maximum, the typical value is a more negative voltage).
 6. Output short-circuit conditions must maintain the total power dissipation below absolute maximum ratings.
 7. Test conditions are those specified by TIA/EIA-232-F and as listed above.

switching characteristics, $V_{CC} = 5\text{ V}$, $V_{DD} = 12\text{ V}$, $V_{SS} = -12\text{ V}$, $T_A = 25^\circ\text{C}$

| PARAMETER | | TEST CONDITIONS | | | MIN | TYP | MAX | UNIT |
|-----------|---|--|--------------------------|-------------------------|-----|-----|-----|---------------|
| t_{PLH} | Propagation delay time, low- to high-level output | $R_L = 3\text{ k}\Omega$ to $7\text{ k}\Omega$, | $C_L = 15\text{ pF}$, | See Figure 3 | | 315 | 500 | ns |
| t_{PHL} | Propagation delay time, high- to low-level output | $R_L = 3\text{ k}\Omega$ to $7\text{ k}\Omega$, | $C_L = 15\text{ pF}$, | See Figure 3 | | 75 | 175 | ns |
| t_{TLH} | Transition time, low- to high-level output | $R_L = 3\text{ k}\Omega$ to $7\text{ k}\Omega$ | $C_L = 15\text{ pF}$, | See Figure 3 | | 60 | 100 | ns |
| | | | $C_L = 2500\text{ pF}$, | See Figure 3 and Note 8 | | 1.7 | 2.5 | μs |
| t_{THL} | Transition time, high- to low-level output | $R_L = 3\text{ k}\Omega$ to $7\text{ k}\Omega$ | $C_L = 15\text{ pF}$, | See Figure 3 | | 40 | 75 | ns |
| | | | $C_L = 2500\text{ pF}$, | See Figure 3 and Note 8 | | 1.5 | 2.5 | μs |

NOTE 8: Measured between $\pm 3\text{-V}$ and $\pm 3\text{-V}$ points of the output waveform (TIA/EIA-232-F conditions); all unused inputs are tied either high or low.

勝特力材料 886-3-5753170
 勝特力电子(上海) 86-21-54151736
 勝特力电子(深圳) 86-755-83298787
[Http://www.100y.com.tw](http://www.100y.com.tw)



GD65232, GD75232 MULTIPLE RS-232 DRIVERS AND RECEIVERS

SLLS206J – MAY 1995 – REVISED NOVEMBER 2004

RECEIVER SECTION

electrical characteristics over recommended operating conditions (unless otherwise noted)

| PARAMETER | | TEST CONDITIONS | | MIN | TYP† | MAX | UNIT |
|------------------|---|-------------------------------|--------------------------|---------|-------|------|------|
| V _{IT+} | Positive-going input threshold voltage | T _A = 25°C, | See Figure 5 | 1.75 | 1.9 | 2.3 | V |
| | | T _A = 0°C to 70°C, | See Figure 5 | 1.55 | | 2.3 | |
| V _{IT-} | Negative-going input threshold voltage | | | 0.75 | 0.97 | 1.25 | V |
| V _{hys} | Input hysteresis voltage (V _{IT+} - V _{IT-}) | | | 0.5 | | | V |
| V _{OH} | High-level output voltage | I _{OH} = -0.5 mA | V _{IH} = 0.75 V | 2.6 | 4 | 5 | V |
| | | | Inputs open | 2.6 | | | |
| V _{OL} | Low-level output voltage | I _{OL} = 10 mA, | V _I = 3 V | | 0.2 | 0.45 | V |
| I _{IH} | High-level input current | V _I = 25 V, | See Figure 5 | GD65232 | 3.6 | 11 | mA |
| | | | | GD75232 | 3.6 | 8.3 | |
| | | V _I = 3 V, | See Figure 5 | | 0.43 | | |
| I _{IL} | Low-level input current | V _I = -25 V, | See Figure 5 | GD65232 | -3.6 | -11 | mA |
| | | | | GD75232 | -3.6 | -8.3 | |
| | | V _I = -3 V, | See Figure 5 | | -0.43 | | |
| I _{OS} | Short-circuit output current | See Figure 4 | | | -3.4 | -12 | mA |

† All typical values are at T_A = 25°C, V_{CC} = 5 V, V_{DD} = 9 V, and V_{SS} = -9 V.

switching characteristics, V_{CC} = 5 V, V_{DD} = 12 V, V_{SS} = -12 V, T_A = 25°C

| PARAMETER | | TEST CONDITIONS | | MIN | TYP | MAX | UNIT |
|------------------|---|---|--|-----|-----|-----|------|
| t _{PLH} | Propagation delay time, low- to high-level output | C _L = 50 pF, R _L = 5 kΩ, See Figure 6 | | | 107 | 250 | ns |
| t _{PHL} | Propagation delay time, high- to low-level output | | | | 42 | 150 | ns |
| t _{TLH} | Transition time, low- to high-level output | | | | 175 | 350 | ns |
| t _{THL} | Transition time, high- to low-level output | | | | 16 | 60 | ns |
| t _{PLH} | Propagation delay time, low- to high-level output | C _L = 15 pF, R _L = 1.5 kΩ, See Figure 6 | | | 100 | 160 | ns |
| t _{PHL} | Propagation delay time, high- to low-level output | | | | 60 | 100 | ns |
| t _{TLH} | Transition time, low- to high-level output | | | | 90 | 175 | ns |
| t _{THL} | Transition time, high- to low-level output | | | | 15 | 50 | ns |

勝特力材料 886-3-5753170
 勝特力电子(上海) 86-21-54151736
 勝特力电子(深圳) 86-755-83298787
[Http://www.100y.com.tw](http://www.100y.com.tw)



PARAMETER MEASUREMENT INFORMATION

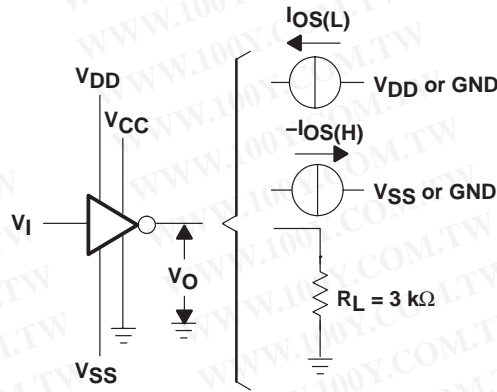

Figure 1. Driver Test Circuit for V_{OH} , V_{OL} , $I_{OS(H)}$, and $I_{OS(L)}$

勝特力材料 886-3-5753170
 勝特力电子(上海) 86-21-54151736
 勝特力电子(深圳) 86-755-83298787
[Http://www.100y.com.tw](http://www.100y.com.tw)

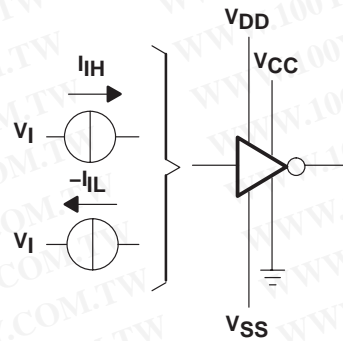
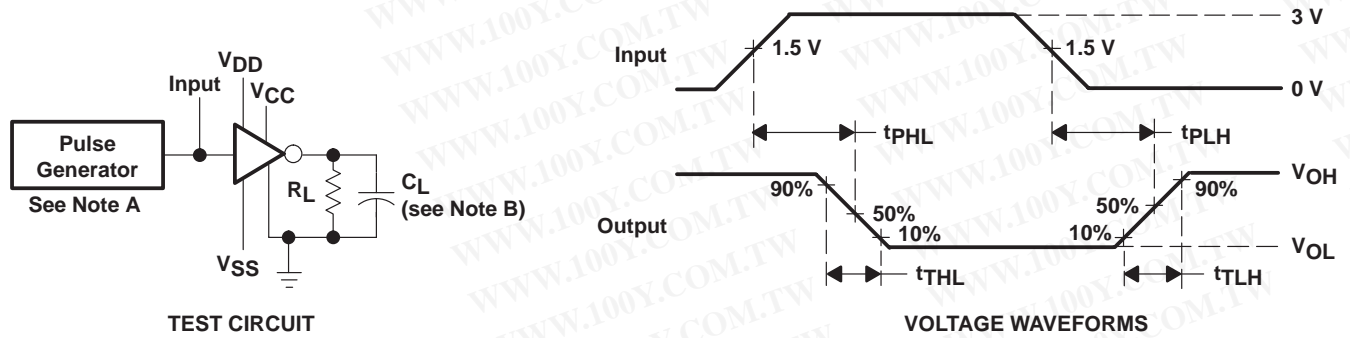

Figure 2. Driver Test Circuit for I_{IH} and I_{IL}



NOTES: A. The pulse generator has the following characteristics: $t_w = 25 \mu s$, $PRR = 20 \text{ kHz}$, $Z_O = 50 \Omega$, $t_r = t_f < 50 \text{ ns}$.
 B. C_L includes probe and jig capacitance.

Figure 3. Driver Test Circuit and Voltage Waveforms

GD65232, GD75232 MULTIPLE RS-232 DRIVERS AND RECEIVERS

SLLS206J – MAY 1995 – REVISED NOVEMBER 2004

PARAMETER MEASUREMENT INFORMATION

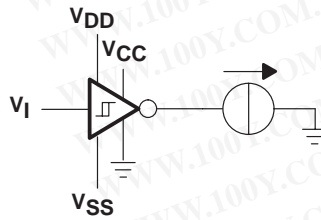

勝特力材料 886-3-5753170
 勝特力电子(上海) 86-21-54151736
 勝特力电子(深圳) 86-755-83298787
[Http://www.100y.com.tw](http://www.100y.com.tw)

Figure 4. Receiver Test Circuit for I_{OS}

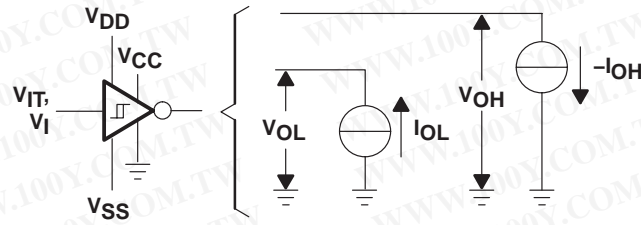
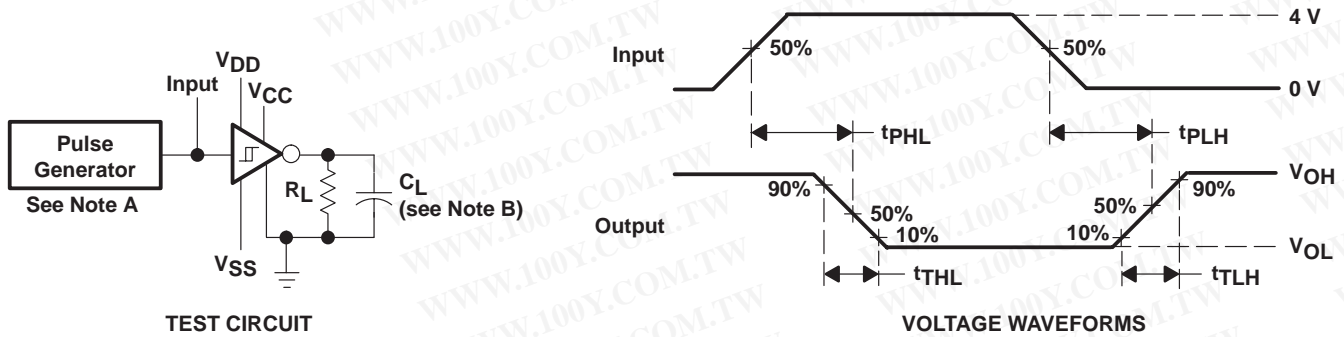

Figure 5. Receiver Test Circuit for V_{IT} , V_{OH} , and V_{OL}



NOTES: A. The pulse generator has the following characteristics: $t_w = 25 \mu s$, $PRR = 20 \text{ kHz}$, $Z_O = 50 \Omega$, $t_r = t_f < 50 \text{ ns}$.
 B. C_L includes probe and jig capacitance.

Figure 6. Receiver Propagation and Transition Times

TYPICAL CHARACTERISTICS

DRIVER SECTION

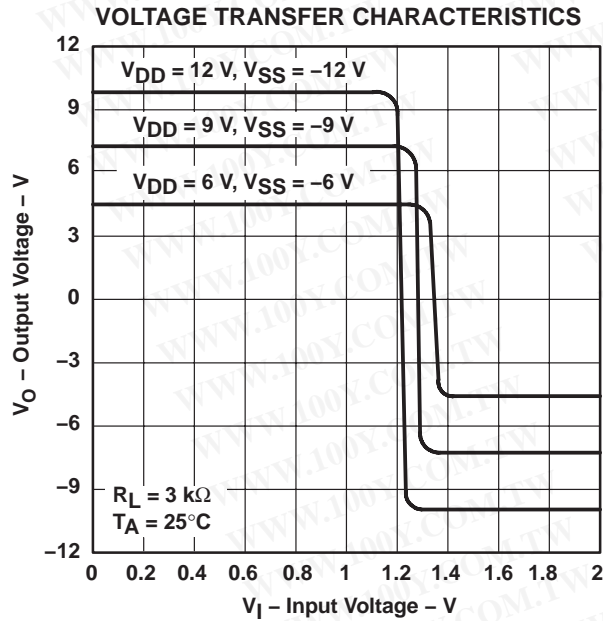

Figure 7

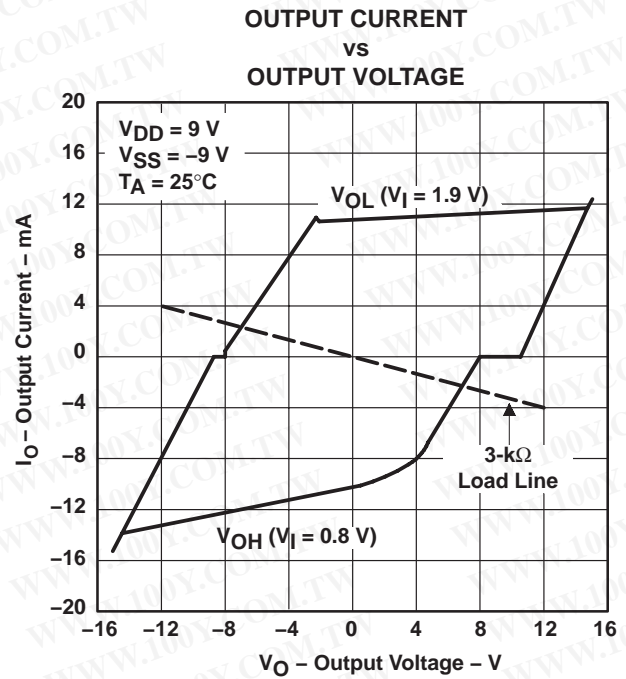

Figure 8

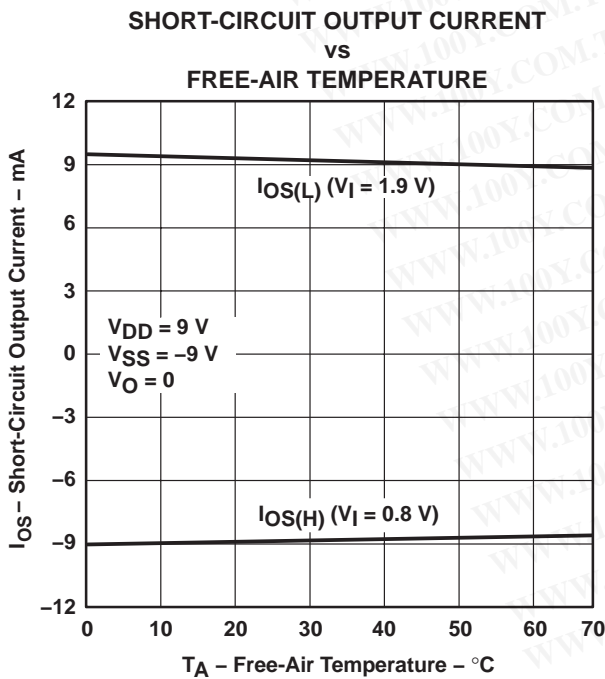

Figure 9

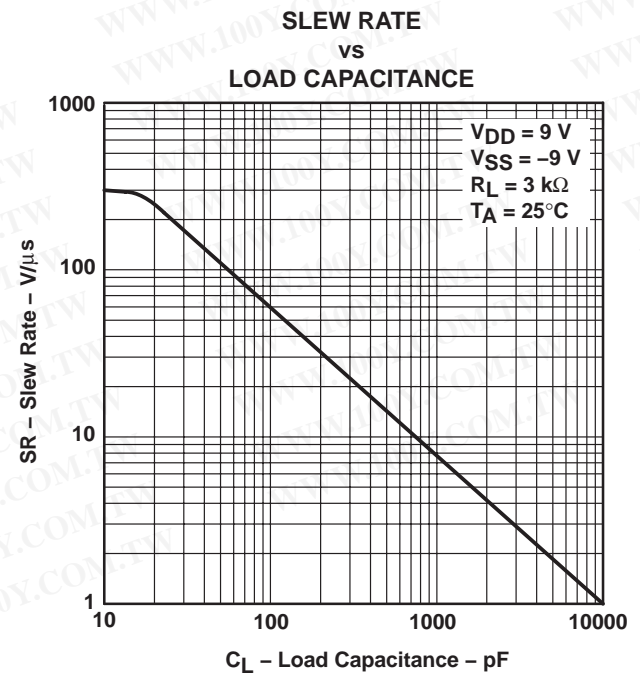

Figure 10

勝特力材料 886-3-5753170
 勝特力电子(上海) 86-21-54151736
 勝特力电子(深圳) 86-755-83298787
[Http://www.100y.com.tw](http://www.100y.com.tw)

TYPICAL CHARACTERISTICS

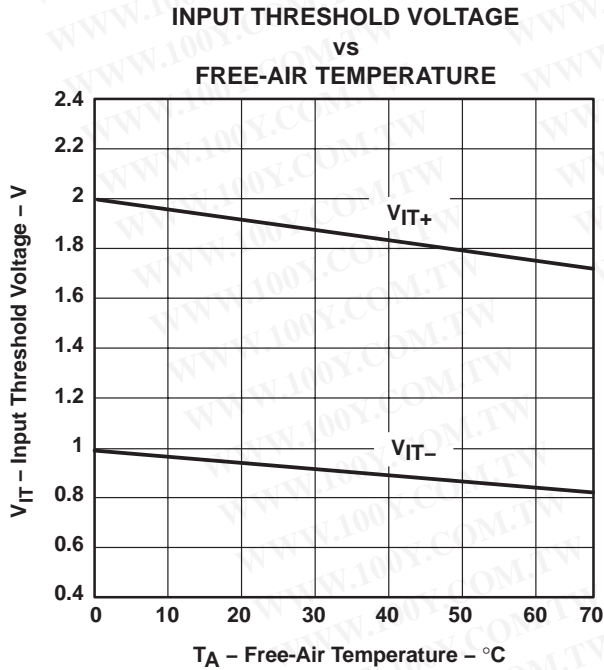

Figure 11

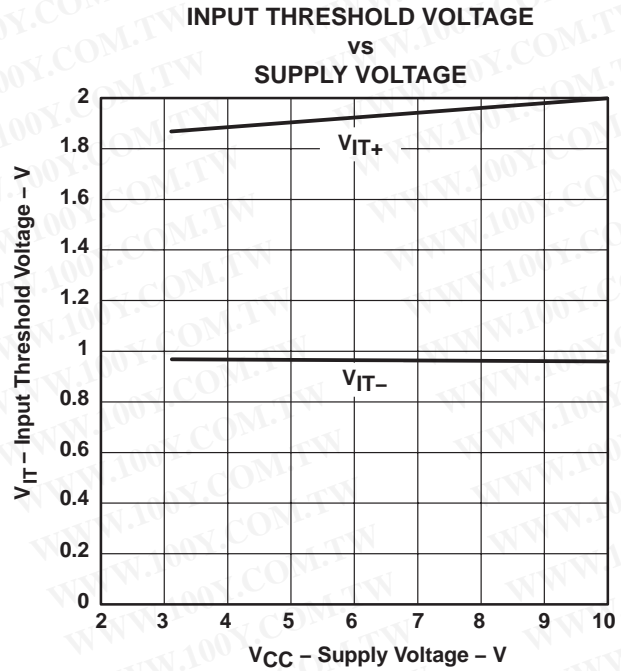
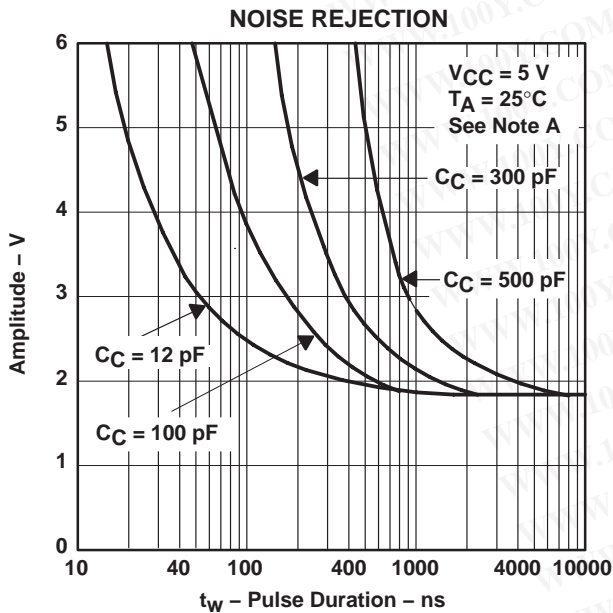

Figure 12



NOTE A: This figure shows the maximum amplitude of a positive-going pulse that, starting from 0 V, does not cause a change of the output level.

Figure 13

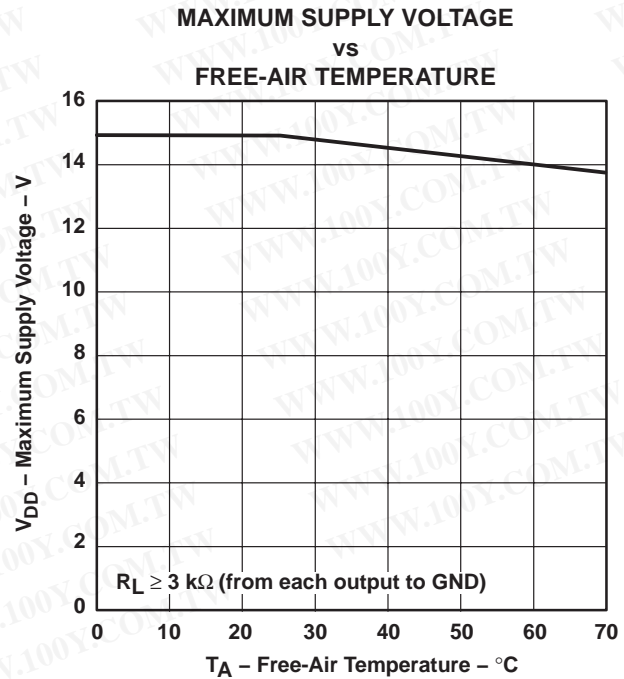

Figure 14

APPLICATION INFORMATION

Diodes placed in series with the V_{DD} and V_{SS} leads protect the GD65232 and GD75232 in the fault condition in which the device outputs are shorted to ± 15 V and the power supplies are at low and provide low-impedance paths to ground (see Figure 15).

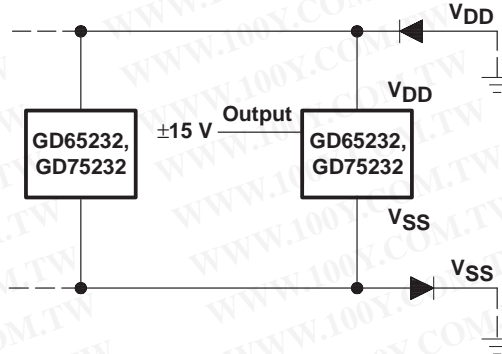

Figure 15. Power-Supply Protection to Meet Power-Off Fault Conditions of TIA/EIA-232-F

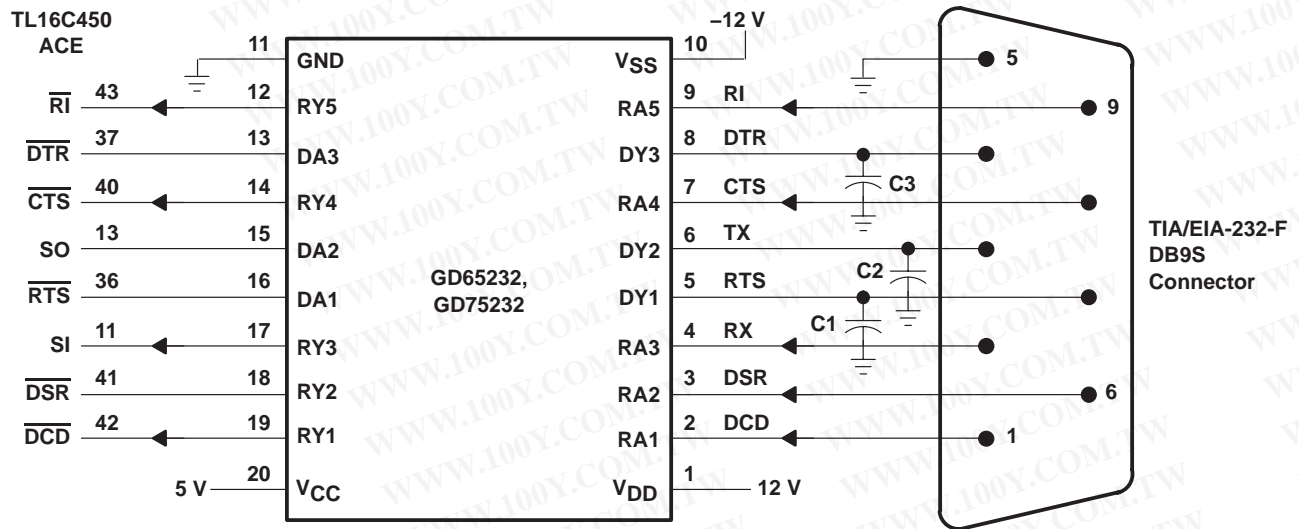

Figure 16. Typical Connection

PACKAGING INFORMATION

| Orderable Device | Status ⁽¹⁾ | Package Type | Package Drawing | Pins | Package Qty | Eco Plan ⁽²⁾ | Lead/Ball Finish | MSL Peak Temp ⁽³⁾ |
|------------------|-----------------------|--------------|-----------------|------|-------------|-------------------------|------------------|------------------------------|
| GD65232DBR | ACTIVE | SSOP | DB | 20 | 2000 | Green (RoHS & no Sb/Br) | CU NIPDAU | Level-1-260C-UNLIM |
| GD65232DBRE4 | ACTIVE | SSOP | DB | 20 | 2000 | Green (RoHS & no Sb/Br) | CU NIPDAU | Level-1-260C-UNLIM |
| GD65232DW | ACTIVE | SOIC | DW | 20 | 25 | Green (RoHS & no Sb/Br) | CU NIPDAU | Level-1-260C-UNLIM |
| GD65232DWE4 | ACTIVE | SOIC | DW | 20 | 25 | Green (RoHS & no Sb/Br) | CU NIPDAU | Level-1-260C-UNLIM |
| GD65232DWR | ACTIVE | SOIC | DW | 20 | 2000 | Green (RoHS & no Sb/Br) | CU NIPDAU | Level-1-260C-UNLIM |
| GD65232DWRE4 | ACTIVE | SOIC | DW | 20 | 2000 | Green (RoHS & no Sb/Br) | CU NIPDAU | Level-1-260C-UNLIM |
| GD65232N | ACTIVE | PDIP | N | 20 | 20 | Pb-Free (RoHS) | CU NIPDAU | N / A for Pkg Type |
| GD65232NE4 | ACTIVE | PDIP | N | 20 | 20 | Pb-Free (RoHS) | CU NIPDAU | N / A for Pkg Type |
| GD65232PW | ACTIVE | TSSOP | PW | 20 | 70 | Green (RoHS & no Sb/Br) | CU NIPDAU | Level-1-260C-UNLIM |
| GD65232PWE4 | ACTIVE | TSSOP | PW | 20 | 70 | Green (RoHS & no Sb/Br) | CU NIPDAU | Level-1-260C-UNLIM |
| GD65232PWR | ACTIVE | TSSOP | PW | 20 | 2000 | Green (RoHS & no Sb/Br) | CU NIPDAU | Level-1-260C-UNLIM |
| GD65232PWRE4 | ACTIVE | TSSOP | PW | 20 | 2000 | Green (RoHS & no Sb/Br) | CU NIPDAU | Level-1-260C-UNLIM |
| GD75232DB | OBSOLETE | SSOP | DB | 20 | | TBD | Call TI | Call TI |
| GD75232DBR | ACTIVE | SSOP | DB | 20 | 2000 | Green (RoHS & no Sb/Br) | CU NIPDAU | Level-1-260C-UNLIM |
| GD75232DBRE4 | ACTIVE | SSOP | DB | 20 | 2000 | Green (RoHS & no Sb/Br) | CU NIPDAU | Level-1-260C-UNLIM |
| GD75232DBRG4 | ACTIVE | SSOP | DB | 20 | 2000 | Green (RoHS & no Sb/Br) | CU NIPDAU | Level-1-260C-UNLIM |
| GD75232DW | ACTIVE | SOIC | DW | 20 | 25 | Green (RoHS & no Sb/Br) | CU NIPDAU | Level-1-260C-UNLIM |
| GD75232DWE4 | ACTIVE | SOIC | DW | 20 | 25 | Green (RoHS & no Sb/Br) | CU NIPDAU | Level-1-260C-UNLIM |
| GD75232DWG4 | ACTIVE | SOIC | DW | 20 | 25 | Green (RoHS & no Sb/Br) | CU NIPDAU | Level-1-260C-UNLIM |
| GD75232DWR | ACTIVE | SOIC | DW | 20 | 2000 | Green (RoHS & no Sb/Br) | CU NIPDAU | Level-1-260C-UNLIM |
| GD75232DWRE4 | ACTIVE | SOIC | DW | 20 | 2000 | Green (RoHS & no Sb/Br) | CU NIPDAU | Level-1-260C-UNLIM |
| GD75232DWRG4 | ACTIVE | SOIC | DW | 20 | 2000 | Green (RoHS & no Sb/Br) | CU NIPDAU | Level-1-260C-UNLIM |
| GD75232N | ACTIVE | PDIP | N | 20 | 20 | Pb-Free (RoHS) | CU NIPDAU | N / A for Pkg Type |
| GD75232NE4 | ACTIVE | PDIP | N | 20 | 20 | Pb-Free (RoHS) | CU NIPDAU | N / A for Pkg Type |
| GD75232PW | ACTIVE | TSSOP | PW | 20 | 70 | Green (RoHS & no Sb/Br) | CU NIPDAU | Level-1-260C-UNLIM |

勝特力材料 886-3-5753170
 勝特力电子(上海) 86-21-54151736
 勝特力电子(深圳) 86-755-83298787
[Http://www.100y.com.tw](http://www.100y.com.tw)

| Orderable Device | Status ⁽¹⁾ | Package Type | Package Drawing | Pins | Package Qty | Eco Plan ⁽²⁾ | Lead/Ball Finish | MSL Peak Temp ⁽³⁾ |
|------------------|-----------------------|--------------|-----------------|------|-------------|-------------------------|------------------|------------------------------|
| GD75232PWE4 | ACTIVE | TSSOP | PW | 20 | 70 | Green (RoHS & no Sb/Br) | CU NIPDAU | Level-1-260C-UNLIM |
| GD75232PWR | ACTIVE | TSSOP | PW | 20 | 2000 | Green (RoHS & no Sb/Br) | CU NIPDAU | Level-1-260C-UNLIM |
| GD75232PWRE4 | ACTIVE | TSSOP | PW | 20 | 2000 | Green (RoHS & no Sb/Br) | CU NIPDAU | Level-1-260C-UNLIM |
| GD75232PWRG4 | ACTIVE | TSSOP | PW | 20 | 2000 | Green (RoHS & no Sb/Br) | CU NIPDAU | Level-1-260C-UNLIM |

⁽¹⁾ The marketing status values are defined as follows:

ACTIVE: Product device recommended for new designs.

LIFEBUY: TI has announced that the device will be discontinued, and a lifetime-buy period is in effect.

NRND: Not recommended for new designs. Device is in production to support existing customers, but TI does not recommend using this part in a new design.

PREVIEW: Device has been announced but is not in production. Samples may or may not be available.

OBSOLETE: TI has discontinued the production of the device.

⁽²⁾ Eco Plan - The planned eco-friendly classification: Pb-Free (RoHS), Pb-Free (RoHS Exempt), or Green (RoHS & no Sb/Br) - please check <http://www.ti.com/productcontent> for the latest availability information and additional product content details.

TBD: The Pb-Free/Green conversion plan has not been defined.

Pb-Free (RoHS): TI's terms "Lead-Free" or "Pb-Free" mean semiconductor products that are compatible with the current RoHS requirements for all 6 substances, including the requirement that lead not exceed 0.1% by weight in homogeneous materials. Where designed to be soldered at high temperatures, TI Pb-Free products are suitable for use in specified lead-free processes.

Pb-Free (RoHS Exempt): This component has a RoHS exemption for either 1) lead-based flip-chip solder bumps used between the die and package, or 2) lead-based die adhesive used between the die and leadframe. The component is otherwise considered Pb-Free (RoHS compatible) as defined above.

Green (RoHS & no Sb/Br): TI defines "Green" to mean Pb-Free (RoHS compatible), and free of Bromine (Br) and Antimony (Sb) based flame retardants (Br or Sb do not exceed 0.1% by weight in homogeneous material)

⁽³⁾ MSL, Peak Temp. -- The Moisture Sensitivity Level rating according to the JEDEC industry standard classifications, and peak solder temperature.

Important Information and Disclaimer: The information provided on this page represents TI's knowledge and belief as of the date that it is provided. TI bases its knowledge and belief on information provided by third parties, and makes no representation or warranty as to the accuracy of such information. Efforts are underway to better integrate information from third parties. TI has taken and continues to take reasonable steps to provide representative and accurate information but may not have conducted destructive testing or chemical analysis on incoming materials and chemicals. TI and TI suppliers consider certain information to be proprietary, and thus CAS numbers and other limited information may not be available for release.

In no event shall TI's liability arising out of such information exceed the total purchase price of the TI part(s) at issue in this document sold by TI to Customer on an annual basis.

勝特力材料 886-3-5753170
 勝特力电子(上海) 86-21-54151736
 勝特力电子(深圳) 86-755-83298787
 Http://www.100y.com.tw

N (R-PDIP-T**)

PLASTIC DUAL-IN-LINE PACKAGE

16 PINS SHOWN

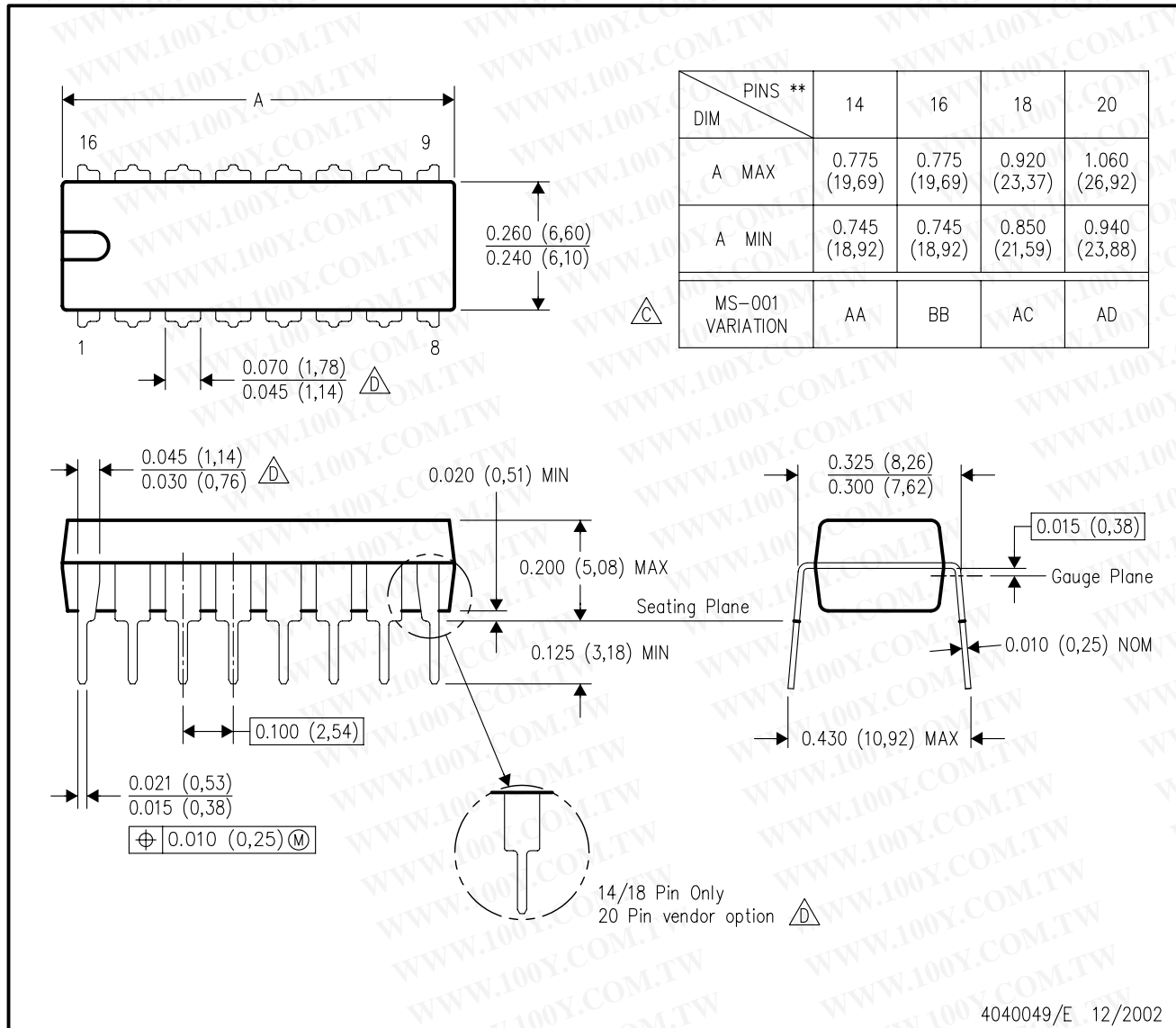

- NOTES:
- A. All linear dimensions are in inches (millimeters).
 - B. This drawing is subject to change without notice.
 - Falls within JEDEC MS-001, except 18 and 20 pin minimum body length (Dim A).
 - The 20 pin end lead shoulder width is a vendor option, either half or full width.

DW (R-PDSO-G20)

PLASTIC SMALL-OUTLINE PACKAGE

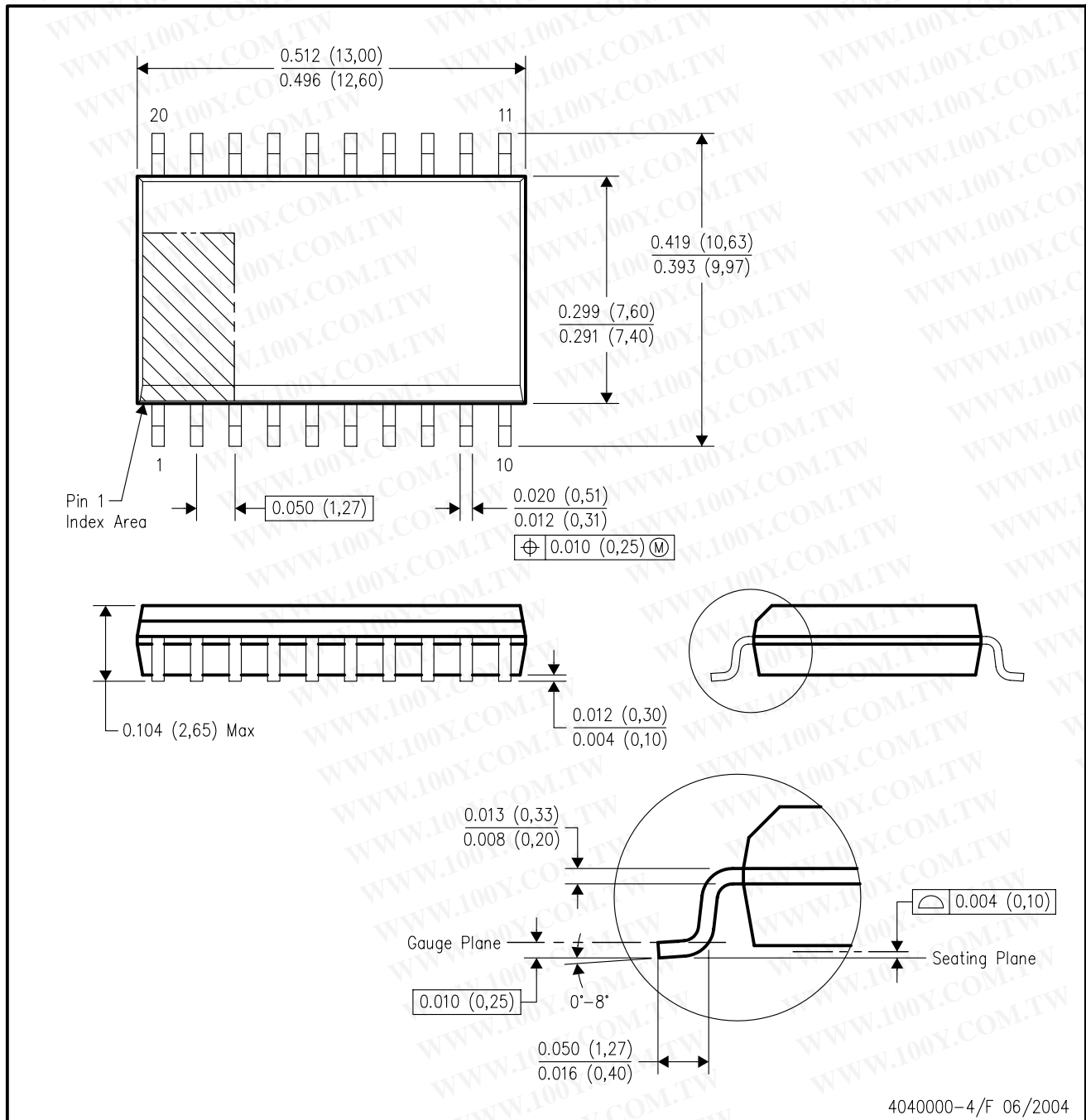

- NOTES:
- A. All linear dimensions are in inches (millimeters).
 - B. This drawing is subject to change without notice.
 - C. Body dimensions do not include mold flash or protrusion not to exceed 0.006 (0,15).
 - D. Falls within JEDEC MS-013 variation AC.

勝特力材料 886-3-5753170
 勝特力电子(上海) 86-21-54151736
 勝特力电子(深圳) 86-755-83298787
[Http://www.100y.com.tw](http://www.100y.com.tw)

MECHANICAL DATA

MSS0002E – JANUARY 1995 – REVISED DECEMBER 2001

DB (R-PDSO-G**)

PLASTIC SMALL-OUTLINE

28 PINS SHOWN

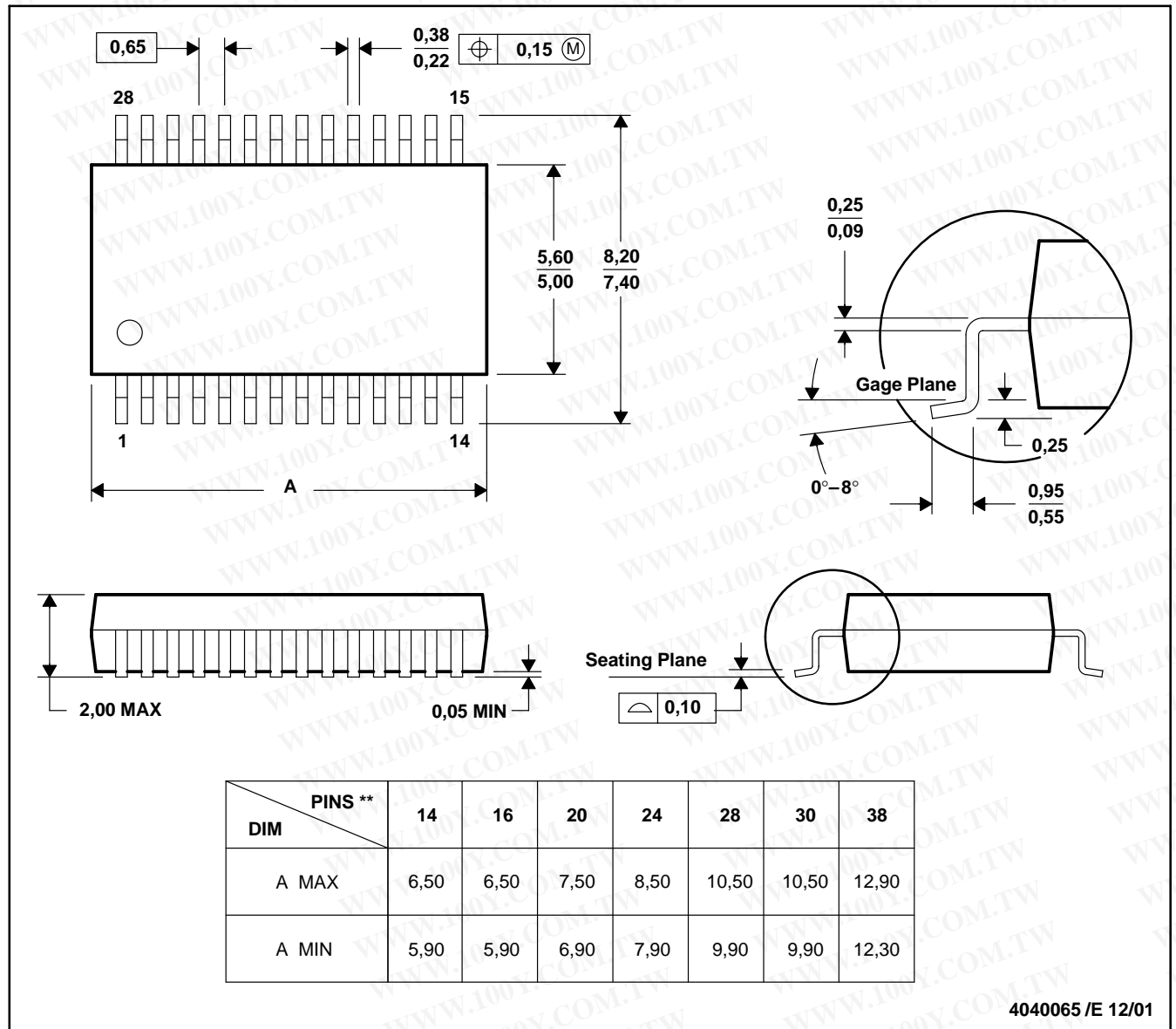

4040065 / E 12/01

- NOTES: A. All linear dimensions are in millimeters.
 B. This drawing is subject to change without notice.
 C. Body dimensions do not include mold flash or protrusion not to exceed 0,15.
 D. Falls within JEDEC MO-150

PW (R-PDSO-G**)

PLASTIC SMALL-OUTLINE PACKAGE

14 PINS SHOWN

勝特力材料 886-3-5753170
 勝特力电子(上海) 86-21-54151736
 勝特力电子(深圳) 86-755-83298787
[Http://www.100y.com.tw](http://www.100y.com.tw)

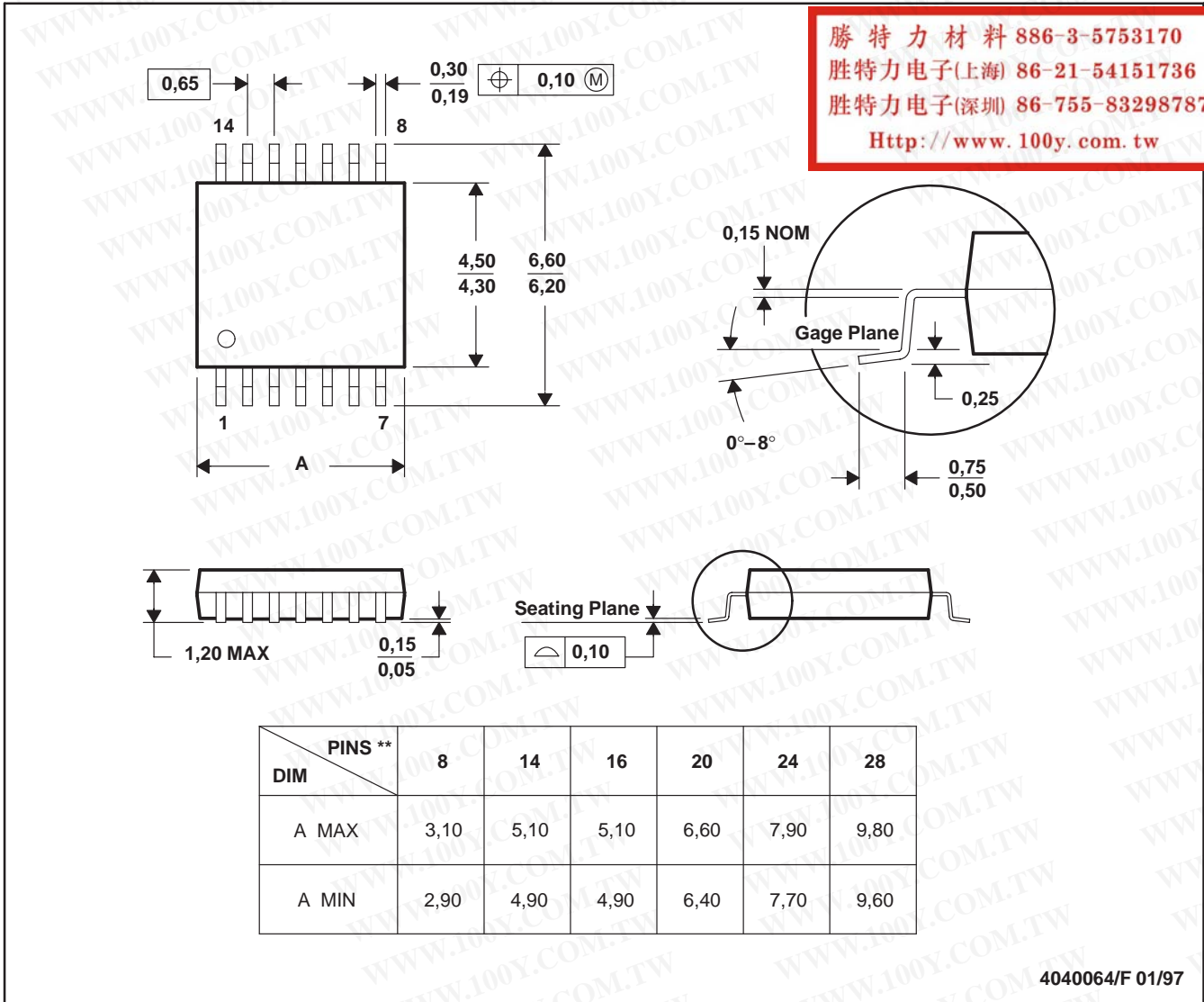

- NOTES: A. All linear dimensions are in millimeters.
 B. This drawing is subject to change without notice.
 C. Body dimensions do not include mold flash or protrusion not to exceed 0,15.
 D. Falls within JEDEC MO-153

勝特力材料 886-3-5753170
勝特力电子(上海) 86-21-54151736
勝特力电子(深圳) 86-755-83298787
[Http://www.100y.com.tw](http://www.100y.com.tw)

IMPORTANT NOTICE

Texas Instruments Incorporated and its subsidiaries (TI) reserve the right to make corrections, modifications, enhancements, improvements, and other changes to its products and services at any time and to discontinue any product or service without notice. Customers should obtain the latest relevant information before placing orders and should verify that such information is current and complete. All products are sold subject to TI's terms and conditions of sale supplied at the time of order acknowledgment.

TI warrants performance of its hardware products to the specifications applicable at the time of sale in accordance with TI's standard warranty. Testing and other quality control techniques are used to the extent TI deems necessary to support this warranty. Except where mandated by government requirements, testing of all parameters of each product is not necessarily performed.

TI assumes no liability for applications assistance or customer product design. Customers are responsible for their products and applications using TI components. To minimize the risks associated with customer products and applications, customers should provide adequate design and operating safeguards.

TI does not warrant or represent that any license, either express or implied, is granted under any TI patent right, copyright, mask work right, or other TI intellectual property right relating to any combination, machine, or process in which TI products or services are used. Information published by TI regarding third-party products or services does not constitute a license from TI to use such products or services or a warranty or endorsement thereof. Use of such information may require a license from a third party under the patents or other intellectual property of the third party, or a license from TI under the patents or other intellectual property of TI.

Reproduction of information in TI data books or data sheets is permissible only if reproduction is without alteration and is accompanied by all associated warranties, conditions, limitations, and notices. Reproduction of this information with alteration is an unfair and deceptive business practice. TI is not responsible or liable for such altered documentation.

Resale of TI products or services with statements different from or beyond the parameters stated by TI for that product or service voids all express and any implied warranties for the associated TI product or service and is an unfair and deceptive business practice. TI is not responsible or liable for any such statements.

Following are URLs where you can obtain information on other Texas Instruments products and application solutions:

| Products | | Applications | |
|------------------|--|---------------------|--|
| Amplifiers | amplifier.ti.com | Audio | www.ti.com/audio |
| Data Converters | dataconverter.ti.com | Automotive | www.ti.com/automotive |
| DSP | dsp.ti.com | Broadband | www.ti.com/broadband |
| Interface | interface.ti.com | Digital Control | www.ti.com/digitalcontrol |
| Logic | logic.ti.com | Military | www.ti.com/military |
| Power Mgmt | power.ti.com | Optical Networking | www.ti.com/opticalnetwork |
| Microcontrollers | microcontroller.ti.com | Security | www.ti.com/security |
| | | Telephony | www.ti.com/telephony |
| | | Video & Imaging | www.ti.com/video |
| | | Wireless | www.ti.com/wireless |

Mailing Address: Texas Instruments
Post Office Box 655303 Dallas, Texas 75265

Copyright © 2006, Texas Instruments Incorporated