

## NC7SZ125 TinyLogic™ UHS Buffer with 3-STATE Output

### General Description

The NC7SZ125 is a single buffer with 3-STATE output from Fairchild's Ultra High Speed Series of TinyLogic™. The device is fabricated with advanced CMOS technology to achieve ultra high speed with high output drive while maintaining low static power dissipation over a very broad  $V_{CC}$  operating range. The device is specified to operate over the 1.65V to 5.5V range.

The inputs and output are high impedance above ground when  $V_{CC}$  is 0V. Inputs tolerate voltages up to 6V independent of  $V_{CC}$  operating voltage. The output tolerates voltages above  $V_{CC}$  when in the 3-STATE condition.

### Features

- Space saving SOT23 or SC70 5-lead package
- Ultra small MicroPak™ leadless package
- Ultra High Speed;  $t_{PD}$  2.6 ns Typ into 50 pF at 5V  $V_{CC}$
- High Output Drive;  $\pm 24$  mA at 3V  $V_{CC}$
- Broad  $V_{CC}$  Operating Range; 1.65V to 5.5V
- Matches the performance of LCX when operated at 3.3V  $V_{CC}$
- Power down high impedance inputs/output
- Overvoltage Tolerant inputs facilitate 5V to 3V translation
- Patented noise/EMI reduction circuitry implemented

### Ordering Code:

Product Number	Package Drawing	Product Code Top Mark	Package Description	Supplied As
NC7SZ125M5X	MA05B	7Z25	5-Lead SOT23, JEDEC MO-178, 1.6mm	3k Units on Tape and Reel
NC7SZ125P5X	MAA05A	Z25	5-Lead SC70, EIAJ SC-88a, 1.25mm Wide	3k Units on Tape and Reel
NC7SZ125L6X	MAC06A (Preliminary)	TBD	6-Lead, MicroPak, Ceramic, 1.0mm Wide	TBD

### Logic Symbol



### Connection Diagram

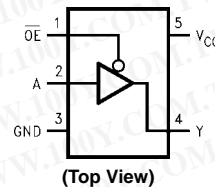

### Pin Descriptions

Pin Names	Description
A, $\overline{OE}$	Inputs
Y	Output

### Function Table

Inputs		Output
$\overline{OE}$	In A	Out Y
L	L	L
L	H	H
H	X	Z

H = HIGH Logic Level  
L = LOW Logic Level  
X = HIGH or LOW Logic Level  
Z = HIGH Impedance State

TinyLogic™ and MicroPak™ are trademarks of Fairchild Semiconductor Corporation.

**Absolute Maximum Ratings** (Note 1)

Supply Voltage ( $V_{CC}$ )	-0.5V to +6V
DC Input Voltage ( $V_{IN}$ )	-0.5V to +6V
DC Output Voltage ( $V_{OUT}$ )	-0.5V to +6V
DC Input Diode Current ( $I_{IK}$ )	
@ $V_{IN} < -0.5V$	-50 mA
@ $V_{IN} > 6V$	+20 mA
DC Output Diode Current ( $I_{OK}$ )	
@ $V_{OUT} < -0.5V$	-50 mA
@ $V_{OUT} > 6V, V_{CC} = GND$	+20 mA
DC Output Current ( $I_{OUT}$ )	$\pm 50$ mA
DC $V_{CC}/GND$ Current ( $I_{CC}/I_{GND}$ )	$\pm 50$ mA
Storage Temperature ( $T_{STG}$ )	-65°C to +150°C
Junction Temperature under Bias ( $T_J$ )	150°C
Junction Lead Temperature ( $T_L$ ); (Soldering, 10 seconds)	260°C
Power Dissipation ( $P_D$ ) @ +85°C	
SOT23-5	200 mW
SC70-5	150 mW

**Recommended Operating Conditions** (Note 2)

Supply Voltage Operating ( $V_{CC}$ )	1.65V to 5.5V
Supply Voltage Data Retention ( $V_{CC}$ )	1.5V to 5.5V
Input Voltage ( $V_{IN}$ )	0V to 5.5V
Output Voltage ( $V_{OUT}$ )	
Active State	0V to $V_{CC}$
3-STATE	0V to 5.5V
Operating Temperature ( $T_A$ )	-40°C to +85°C
Input Rise and Fall Time ( $t_r, t_f$ )	
$V_{CC} = 1.8V, 2.5V \pm 0.2V$	0 ns/V to 20 ns/V
$V_{CC} = 3.3V \pm 0.3V$	0 ns/V to 10 ns/V
$V_{CC} = 5.0V \pm 0.5V$	0 ns/V to 5 ns/V
Thermal Resistance ( $\theta_{JA}$ )	
SOT23-5	300°C/W
SC70-5	425°C/W

**Note 1:** Absolute maximum ratings are DC values beyond which the device may be damaged or have its useful life impaired. The datasheet specifications should be met, without exception, to ensure that the system design is reliable over its power supply, temperature, and output/input loading variables. Fairchild does not recommend operation outside datasheet specifications.

**Note 2:** Unused inputs must be held HIGH or LOW. They may not float.

**DC Electrical Characteristics**

Symbol	Parameter	$V_{CC}$ (V)	$T_A = +25^\circ\text{C}$			$T_A = -40^\circ\text{C to } +85^\circ\text{C}$		Units	Conditions		
			Min	Typ	Max	Min	Max				
$V_{IH}$	HIGH Level Input Voltage	1.65 to 1.95 2.3 to 5.5	0.75 $V_{CC}$ 0.7 $V_{CC}$			0.75 $V_{CC}$ 0.7 $V_{CC}$		V			
$V_{IL}$	LOW Level Input Voltage	1.65 to 1.95 2.3 to 5.5			0.25 $V_{CC}$ 0.3 $V_{CC}$	0.25 $V_{CC}$ 0.3 $V_{CC}$		V			
$V_{OH}$	HIGH Level Output Voltage	1.65	1.55	1.65		1.55		V	$V_{IN} = V_{IH}$ $I_{OH} = -100 \mu\text{A}$		
		1.8	1.7	1.8		1.7					
$V_{OH}$	HIGH Level Output Voltage	2.3	2.2	2.3		2.2		V	$I_{OH} = -4 \text{ mA}$ $I_{OH} = -8 \text{ mA}$ $I_{OH} = -16 \text{ mA}$ $I_{OH} = -24 \text{ mA}$ $I_{OH} = -32 \text{ mA}$		
		3.0	2.9	3.0		2.9					
		4.5	4.4	4.5		4.4					
		1.65	1.29	1.52		1.29					
		2.3	1.9	2.15		1.9					
		3.0	2.4	2.80		2.4					
		3.0	2.3	2.68		2.3					
4.5	3.8	4.20		3.8							
$V_{OL}$	LOW Level Output Voltage	1.65		0.0	0.1		0.0	V	$V_{IN} = V_{IL}$ $I_{OL} = 100 \mu\text{A}$		
		1.8		0.0	0.1		0.1				
		2.3		0.0	0.1		0.1				
		3.0		0.0	0.1		0.1				
		4.5		0.0	0.1		0.1				
		1.65		0.08	0.24		0.24			V	$I_{OL} = 4 \text{ mA}$ $I_{OL} = 8 \text{ mA}$ $I_{OL} = 16 \text{ mA}$ $I_{OL} = 24 \text{ mA}$ $I_{OL} = 32 \text{ mA}$
		2.3		0.10	0.3		0.3				
3.0		0.15	0.4		0.4						
3.0		0.22	0.55		0.55						
4.5		0.22	0.55		0.55						
$I_{IN}$	Input Leakage Current	0 to 5.5			$\pm 1$	$\pm 10$	$\mu\text{A}$	$0 \leq V_{IN} \leq 5.5V$			
$I_{OZ}$	3-STATE						$\mu\text{A}$	$V_{IN} = V_{IH}$ or $V_{IL}$			
	Output Leakage	1.65 to 5.5			$\pm 1$	$\pm 10$	$\mu\text{A}$	$0 \leq V_O \leq 5.5V$			
$I_{OFF}$	Power Off Leakage Current	0.0			1	10	$\mu\text{A}$	$V_{IN}$ or $V_{OUT} = 5.5V$			
$I_{CC}$	Quiescent Supply Current	1.65 to 5.5			2.0	20	$\mu\text{A}$	$V_{IN} = 5.5V, GND$			

AC Electrical Characteristics										
Symbol	Parameter	V <sub>CC</sub> (V)	T <sub>A</sub> = +25°C			T <sub>A</sub> = -40°C to +85°C		Units	Conditions	Figure Number
			Min	Typ	Max	Min	Max			
t <sub>PLH</sub>	Propagation Delay	1.65	2.0	6.4	13.2	2.0	13.8	ns	C <sub>L</sub> = 15 pF, R <sub>D</sub> = 1 MΩ, S <sub>1</sub> = OPEN	Figures 1, 3
t <sub>PHL</sub>		1.8	2.0	5.3	11.0	2.0	11.5			
		2.5 ± 0.2	0.8	3.4	7.5	0.8	8.0			
		3.3 ± 0.3	0.5	2.5	5.2	0.5	5.5			
		5.0 ± 0.5	0.5	2.1	4.5	0.5	4.8			
t <sub>PLH</sub>	Propagation Delay	3.3 ± 0.3	1.5	3.2	5.7	1.5	6.0	ns	C <sub>L</sub> = 50 pF, R <sub>D</sub> = 500Ω, S <sub>1</sub> = OPEN	Figures 1, 3
t <sub>PHL</sub>		5.0 ± 0.5	0.8	2.6	5.0	0.8	5.3			
t <sub>PZL</sub>	Output Enable Time	1.65	2.0	8.4	15.0	2.0	15.6	ns	C <sub>L</sub> = 50 pF, R <sub>D</sub> = 500Ω R <sub>U</sub> = 500Ω S <sub>1</sub> = GND for t <sub>PZH</sub> S <sub>1</sub> = V <sub>IN</sub> for t <sub>PZL</sub> V <sub>IN</sub> = 2 x V <sub>CC</sub>	Figures 1, 3
t <sub>PZH</sub>		1.8	2.0	7.0	12.5	2.0	13			
		2.5 ± 0.2	1.5	4.6	8.5	1.5	9			
		3.3 ± 0.3	1.5	3.5	6.2	1.5	6.5			
		5.0 ± 0.5	0.8	2.8	5.5	0.8	5.8			
t <sub>PLZ</sub>	Output Disable Time	1.65	2.0	6.5	13.2	2.0	14.5	ns	C <sub>L</sub> = 50 pF, R <sub>D</sub> = 500Ω R <sub>U</sub> = 500Ω S <sub>1</sub> = GND for t <sub>PHZ</sub> S <sub>1</sub> = V <sub>IN</sub> for t <sub>PLZ</sub> V <sub>IN</sub> = 2 x V <sub>CC</sub>	Figures 1, 3
t <sub>PHZ</sub>		1.8	2.0	5.4	11	2.0	12			
		2.5 ± 0.2	1.5	3.5	8	1.5	8.5			
		3.3 ± 0.3	1.0	2.8	5.7	1.0	6			
		5.0 ± 0.5	0.5	2.1	4.7	0.5	5.0			
C <sub>IN</sub>	Input Capacitance	0	4					pF		
C <sub>OUT</sub>	Output Capacitance	0	8							
C <sub>PD</sub>	Power Dissipation	3.3	17					pF	(Note 3)	Figure 2
	Capacitance	5.0	24							

**Note 3:** C<sub>PD</sub> is defined as the value of the internal equivalent capacitance which is derived from dynamic operating current consumption (I<sub>CCD</sub>) at no output loading and operating at 50% duty cycle. (See Figure 2.) C<sub>PD</sub> is related to I<sub>CCD</sub> dynamic operating current by the expression:  
I<sub>CCD</sub> = (C<sub>PD</sub>)(V<sub>CC</sub>)(f<sub>IN</sub>) + (I<sub>CC</sub>static).

### AC Loading and Waveforms

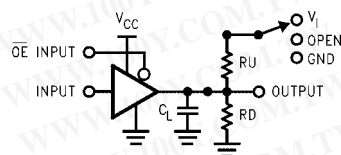

C<sub>L</sub> includes load and stray capacitance  
Input PRR = 1.0 MHz; t<sub>w</sub> = 500 ns

FIGURE 1. AC Test Circuit

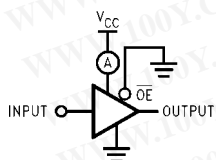

Input = AC Waveform; t<sub>r</sub> = t<sub>f</sub> = 1.8 ns;  
PRR = 10 MHz; Duty Cycle = 50%

FIGURE 2. I<sub>CCD</sub> Test Circuit

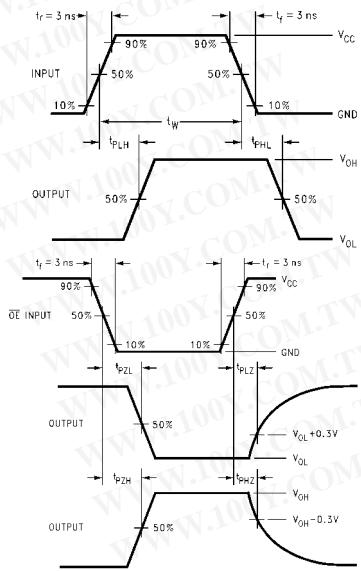

FIGURE 3. AC Waveforms

NC7SZ125

### Tape and Reel Specification

**TAPE FORMAT**

Package Designator	Tape Section	Number Cavities	Cavity Status	Cover Tape Status
M5X, P5X	Leader (Start End)	125 (typ)	Empty	Sealed
	Carrier	3000	Filled	Sealed
	Trailer (Hub End)	75 (typ)	Empty	Sealed
L6X	TBD	TBD	TBD	TBD

**TAPE DIMENSIONS** inches (millimeters)

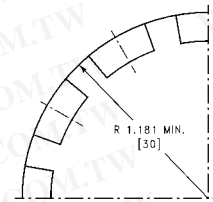
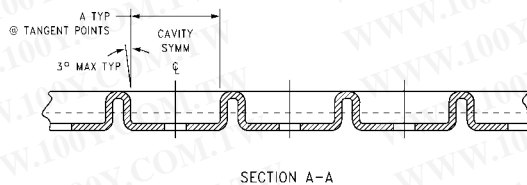
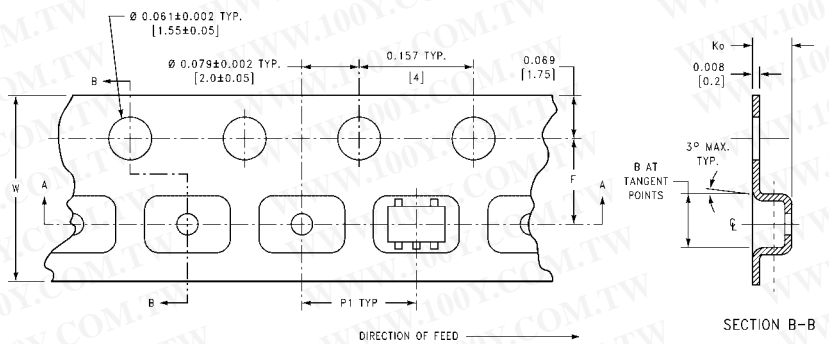

Package	Tape Size	DIM A	DIM B	DIM F	DIM K <sub>0</sub>	DIM P1	DIM W
SC70-5	8 mm	0.093 (2.35)	0.096 (2.45)	0.138 ± 0.004 (3.5 ± 0.10)	0.053 ± 0.004 (1.35 ± 0.10)	0.157 (4)	0.315 ± 0.004 (8 ± 0.1)
SOT23-5	8 mm	0.130 (3.3)	0.130 (3.3)	0.138 ± 0.002 (3.5 ± 0.05)	0.055 ± 0.004 (1.4 ± 0.11)	0.157 (4)	0.315 ± 0.012 (8 ± 0.3)
MicroPak	TBD	TBD	TBD	TBD	TBD	TBD	TBD

**勝特力材料 886-3-5753170**  
**勝特力电子(上海) 86-21-54151736**  
**勝特力电子(深圳) 86-755-83298787**  
[Http://www.100y.com.tw](http://www.100y.com.tw)

### Tape and Reel Specification (Continued)

REEL DIMENSIONS inches (millimeters)

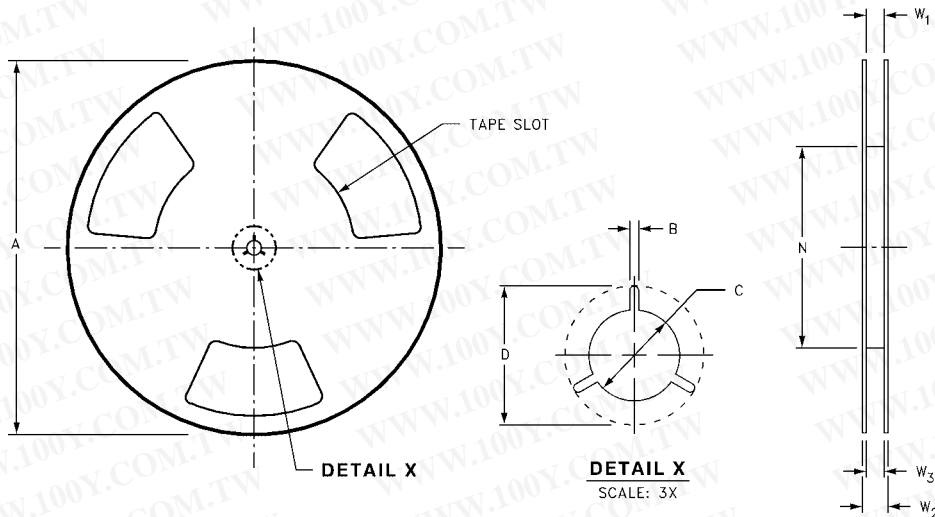

Tape Size	A	B	C	D	N	W1	W2	W3
8 mm	7.0 (177.8)	0.059 (1.50)	0.512 (13.00)	0.795 (20.20)	2.165 (55.00)	0.331 + 0.059/-0.000 (8.40 + 1.50/-0.00)	0.567 (14.40)	W1 + 0.078/-0.039 (W1 + 2.00/-1.00)

勝特力材料 886-3-5753170  
 勝特力电子(上海) 86-21-54151736  
 勝特力电子(深圳) 86-755-83298787  
[Http://www.100y.com.tw](http://www.100y.com.tw)

NC7SZ125

**Physical Dimensions** inches (millimeters) unless otherwise noted

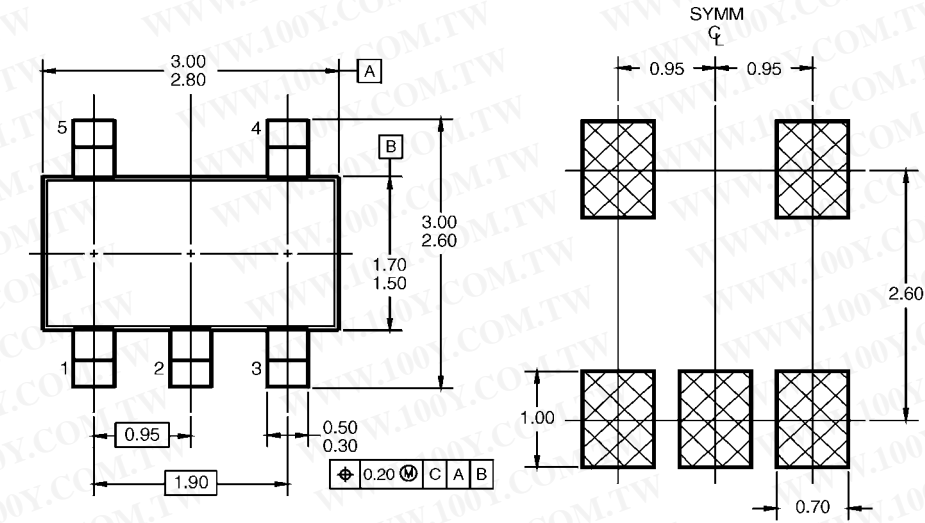

**LAND PATTERN RECOMMENDATION**

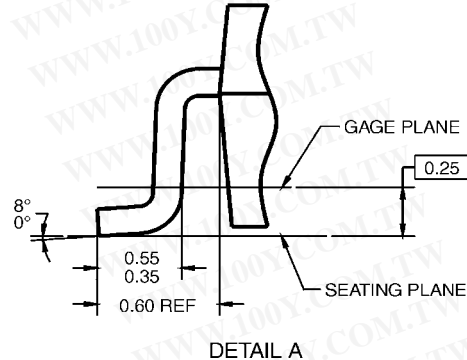
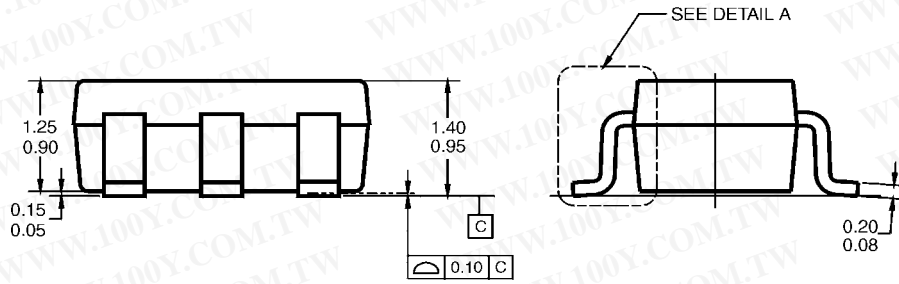

- NOTES: UNLESS OTHERWISE SPECIFIED
- A) THIS PACKAGE CONFORMS TO JEDEC MO-178, ISSUE B, VARIATION AA, DATED JANUARY 1999.
  - B) ALL DIMENSIONS ARE IN MILLIMETERS.

MA05BRevC

5-Lead SOT23, JEDEC MO-178, 1.6mm  
Package Number MA05B

勝特力材料 886-3-5753170  
 勝特力电子(上海) 86-21-54151736  
 勝特力电子(深圳) 86-755-83298787  
[Http://www.100y.com.tw](http://www.100y.com.tw)

**Physical Dimensions** inches (millimeters) unless otherwise noted (Continued)

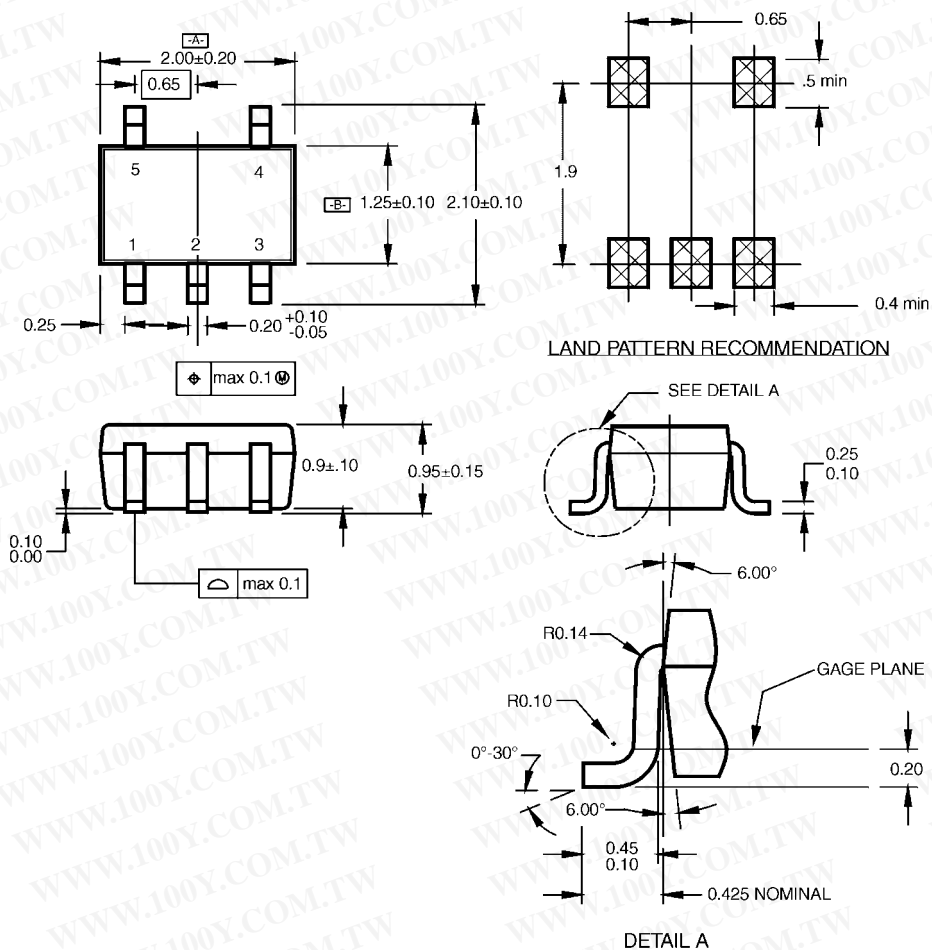

NOTES:

- A. CONFORMS TO EIAJ REGISTERED OUTLINE DRAWING SC88A.
- B. DIMENSIONS DO NOT INCLUDE BURRS OR MOLD FLASH.
- C. DIMENSIONS ARE IN MILLIMETERS.

MAA05ARevC

**5-Lead SC70, EIAJ SC-88a, 1.25mm Wide  
Package Number MAA05A**

勝特力材料 886-3-5753170  
 勝特力电子(上海) 86-21-54151736  
 勝特力电子(深圳) 86-755-83298787  
 Http://www.100y.com.tw

