

Thick Film Chip Resistors 0201, 0402, 0603, 0805, 1206, 1210, 1812, 2010, 2512

Type: **ERJ 1G, 2G, 3G, 6G, 8G, 14,
12, 12Z, 1T**

■ Features

- Small size and lightweight
- High reliability
Metal glaze thick film resistive element and three layers of electrodes
- Compatible with placement machines
Taping and bulk case packaging available
- Suitable for both reflow and flow soldering
- Approved under the ISO 9001 system
Approved under the QS-9000 system
- Reference Standards
IEC 60115-8, JIS C 5201-8, EIAJ RC-2134A

勝特力材料 886-3-5753170
 勝特力电子(上海) 86-21-54151736
 勝特力电子(深圳) 86-755-83298787
[Http://www.100y.com.tw](http://www.100y.com.tw)

■ Explanation of Part Numbers

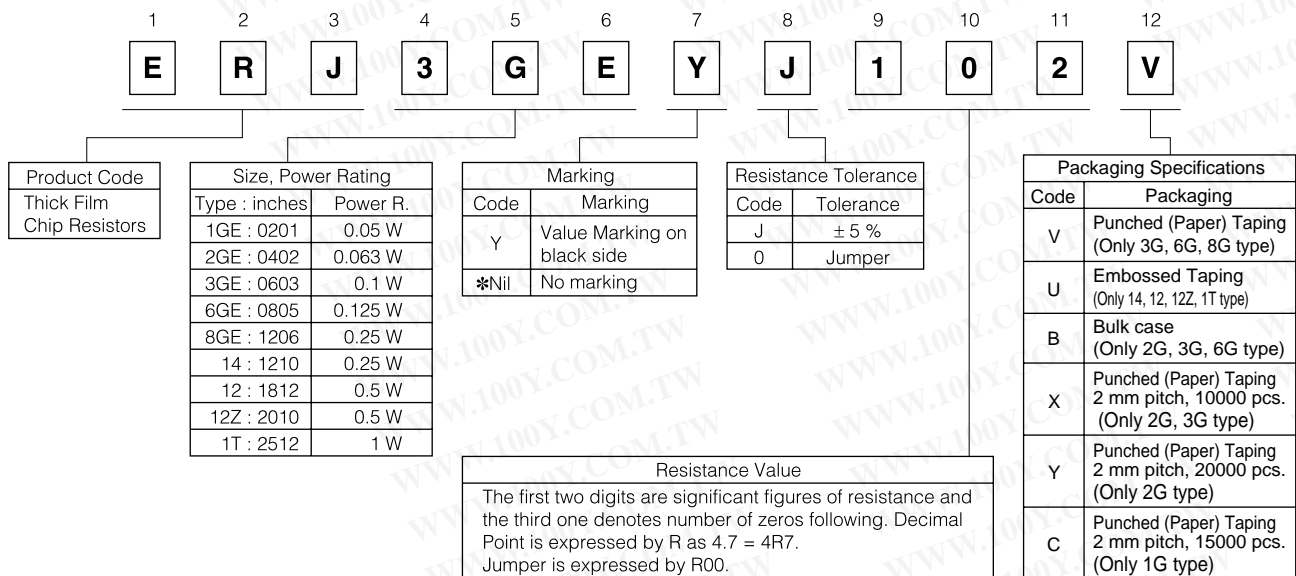

* When partly omitted, all the rest P/N factors should be moved up respectively.

Construction

勝特力材料 886-3-5753170
 勝特力电子(上海) 86-21-54151736
 勝特力电子(深圳) 86-755-83298787
[Http://www.100y.com.tw](http://www.100y.com.tw)

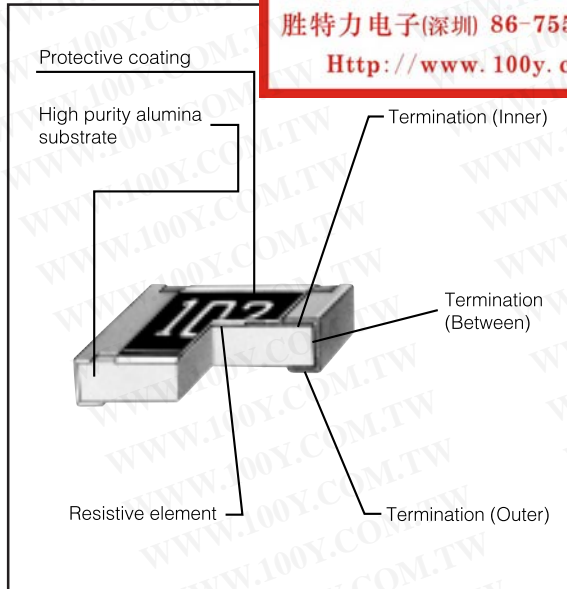

Dimensions in mm (not to scale)

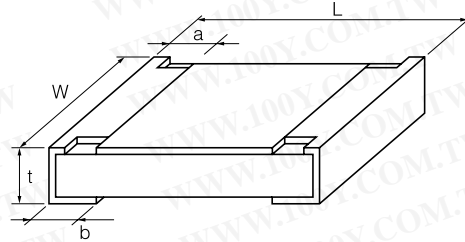

Type (inches)	Dimensions (mm)					Weight (1000 pcs.)
	L	W	a	b	t	
ERJ1G (0201)	0.60 ^{+0.03}	0.30 ^{+0.03}	0.12 ^{+0.05}	0.15 ^{+0.05}	0.25 ^{+0.05}	0.15 g
ERJ2G (0402)	1.00 ^{+0.05}	0.50 ^{+0.05}	0.20 ^{+0.10}	0.25 ^{+0.05}	0.35 ^{+0.05}	0.8 g
ERJ3G (0603)	1.60 ^{+0.15}	0.80 ^{+0.15}	0.30 ^{+0.20}	0.30 ^{+0.15}	0.45 ^{+0.10}	2 g
ERJ6G (0805)	2.00 ^{+0.20}	1.25 ^{+0.10}	0.40 ^{+0.20}	0.40 ^{+0.20}	0.60 ^{+0.10}	4 g
ERJ8G (1206)	3.20 ^{+0.25}	1.60 ^{+0.15}	0.50 ^{+0.20}	0.50 ^{+0.20}	0.60 ^{+0.10}	10 g
ERJ14 (1210)	3.20 ^{+0.20}	2.50 ^{+0.20}	0.50 ^{+0.20}	0.50 ^{+0.20}	0.60 ^{+0.10}	16 g
ERJ12 (1812)	4.50 ^{+0.20}	3.20 ^{+0.20}	0.50 ^{+0.20}	0.50 ^{+0.20}	0.60 ^{+0.10}	27 g
ERJ12Z (2010)	5.00 ^{+0.20}	2.50 ^{+0.20}	0.60 ^{+0.20}	0.60 ^{+0.20}	0.60 ^{+0.10}	27 g
ERJ1T (2512)	6.40 ^{+0.20}	3.20 ^{+0.20}	0.65 ^{+0.20}	0.60 ^{+0.20}	0.60 ^{+0.10}	45 g

Ratings

Type (inches)	Power Rating at 70 °C (W)	Limiting Element Voltage (Maximum RCWV ⁽¹⁾ (V)	Maximum Overload Voltage ⁽²⁾ (V)	Resistance Tolerance(%)	Resistance Range (Ω)		T.C.R. ×10 ⁻⁶ /°C (ppm/°C)	Standard Resistance Values
					min.	max.		
ERJ1G (0201)	0.05	15	30	± 5	10	1 M	<10 Ω: -100 to +600	E24
ERJ2G (0402)	0.063	50	100	± 5	1	2.2 M		E24
ERJ3G (0603)	0.1	50	100	± 5	1	10 M		E24
ERJ6G (0805)	0.125	150	200	± 5	1	10 M	10 Ω to 1 MΩ: ±200	E24
ERJ8G (1206)	0.25	200	400	± 5	1	10 M		E24
ERJ14 (1210)	0.25	200	400	± 5	1	10 M	1 MΩ<: -400 to +150	E24
ERJ12, 12Z (1812, 2010)	0.5	200	400	± 5	1	10 M		E24
ERJ1T (2512)	1	200	400	± 5	1	1 M	E24	

		Rated Current	Maximum Overload Current
Jumper	1G	0.5 A	1 A
	2G · 3G	1 A	2 A
	6G · 8G · 14 · 12 · 12Z · 1T	2 A	4 A

(1) Rated Continuous Working Voltage (RCWV) should be determined from $RCWV = \sqrt{\text{Power Rating} \times \text{Resistance Values}}$, or Limiting Element Voltage (max. RCWV) listed above, whichever is less.

(2) Overload (Short-time Overload) Test Voltage (SOTV) should be determined from $SOTV = 2.5 \times \text{Power Rating}$ or max. Overload Voltage listed above whichever is less.

Power Derating Curve

For resistors operating in ambient temperature above 70 °C, power rating should be derated in accordance with the right figure.

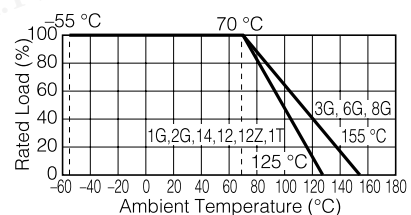

■ Packaging Specifications

● Standard Quantity

Type (inches)	Thickness (mm)	Punched (Paper) Taping	Embossed Taping (4 mm pitch)	Bulk Case
ERJ1G (0201)	0.25	15000 pcs./reel (2 mm pitch)		
ERJ2G (0402)	0.35	10000 pcs./reel (2 mm pitch) 20000 pcs./reel (2 mm pitch)		50000 pcs./case
ERJ3G (0603)	0.45	10000 pcs./reel (2 mm pitch) 5000 pcs./reel (4 mm pitch)*		25000 pcs./case
ERJ6G (0805)	0.6	5000 pcs./reel (4 mm pitch)*		10000 pcs./case
ERJ8G (1206)	0.6	5000 pcs./reel (4 mm pitch)*		
ERJ14 (1210)	0.6		5000 pcs./reel	
ERJ12,12Z (1812,2010)	0.6		5000 pcs./reel	
ERJ1T (2512)	0.6		4000 pcs./reel	

* Please consult us if resistors other than shown above are needed.

● Taping Reel

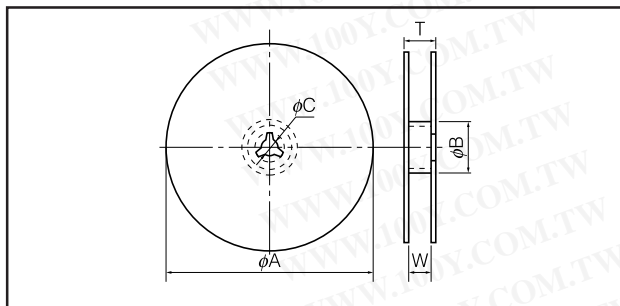

Dimensions (mm)	Type	ϕA	ϕB	ϕC	W	T
	1G,2G,3G	180.0 $_{-0.30}^0$	60 min.	13.0 $_{\pm 1.0}$	9.0 $_{\pm 1.0}$	11.4 $_{\pm 2.0}$
	6G,8G,14				13.0 $_{\pm 1.0}$	15.4 $_{\pm 2.0}$
	12,12Z,1T					

● Bulk Case

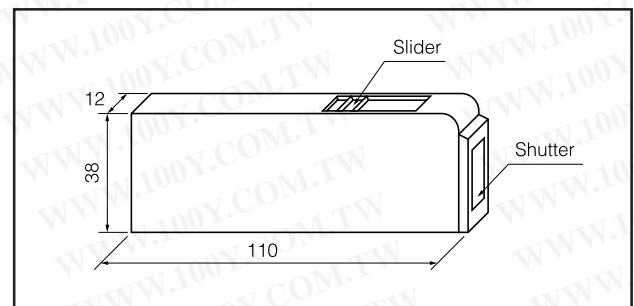

● Punched (Paper) Taping

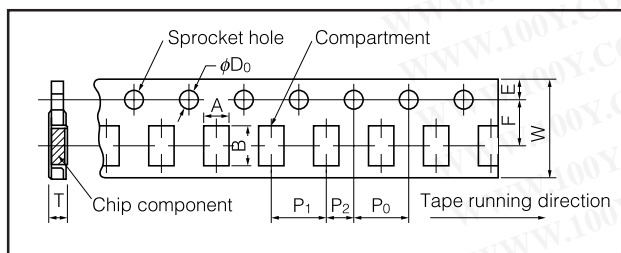

Dimensions (mm)	Type	A	B	W	F	E
	1G	0.38 $_{\pm 0.05}$	0.68 $_{\pm 0.05}$	8.00 $_{\pm 0.20}$	3.50 $_{\pm 0.05}$	1.75 $_{\pm 0.10}$
	2G	0.70 $_{\pm 0.05}$	1.20 $_{\pm 0.05}$			
	3G	1.10 $_{\pm 0.10}$	1.90 $_{\pm 0.10}$			
	6G	1.65 $_{\pm 0.15}$	2.50 $_{\pm 0.20}$			
	8G	2.00 $_{\pm 0.15}$	3.60 $_{\pm 0.20}$			

Dimensions (mm)	Type	P ₁	P ₂	P ₀	ϕD_0	T
	1G	2.00 $_{\pm 0.10}$	2.00 $_{\pm 0.05}$	4.00 $_{\pm 0.10}$	1.50 $_{\pm 0.10}$	0.47 $_{\pm 0.05}$
	2G					0.52 $_{\pm 0.05}$
	3G					0.70 $_{\pm 0.05}$
	6G					0.84 $_{\pm 0.05}$
	8G					

● Embossed Taping

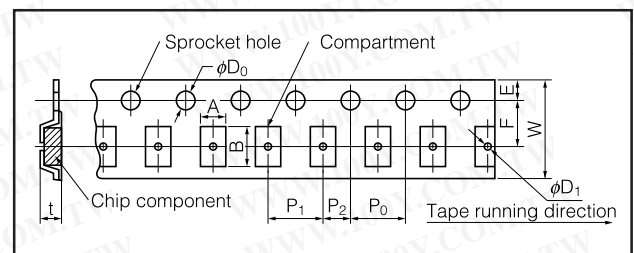

Dimensions (mm)	Type	A	B	W	F	E	P ₁
	14	2.80 $_{\pm 0.20}$	3.50 $_{\pm 0.20}$	8.00 $_{\pm 0.30}$	3.50 $_{\pm 0.05}$	1.75 $_{\pm 0.10}$	4.00 $_{\pm 0.10}$
	12	3.50 $_{\pm 0.20}$	4.80 $_{\pm 0.20}$	12.00 $_{\pm 0.30}$	5.50 $_{\pm 0.05}$		
	12Z	2.80 $_{\pm 0.20}$	5.30 $_{\pm 0.20}$				
	1T	3.60 $_{\pm 0.20}$	6.90 $_{\pm 0.20}$				

Dimensions (mm)	Type	P ₂	P ₀	ϕD_0	t	ϕD_1
	14	2.00 $_{\pm 0.05}$	4.00 $_{\pm 0.10}$	1.50 $_{\pm 0.10}$	1.00 $_{\pm 0.10}$	1 min.
	12					1.5 min.
	12Z					
	1T					

Recommended Land Pattern

In case of flow soldering, the land width must be smaller than the Chip Resistor width to control the solder amount properly. Generally, the land width should be 0.7 to 0.8 times the width of chip the resistor. In case of reflow soldering, solder amount can be adjusted, therefore the land width should be set to 1.0 to 1.3 times chip resistor width (W).

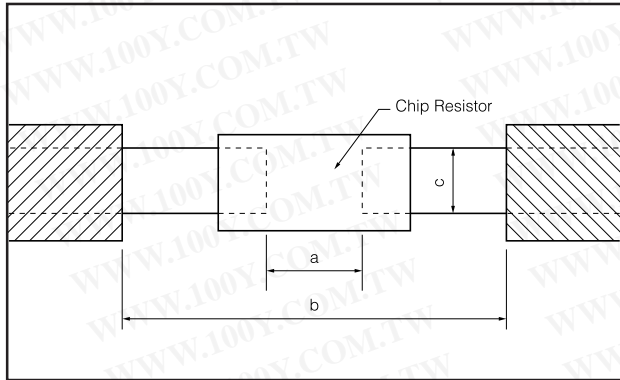

Type (inches)	Dimensions (mm)		
	a	b	c
ERJ1G(0201)	0.3 to 0.4	0.8 to 0.9	0.25 to 0.35
ERJ2G(0402)	0.5 to 0.6	1.4 to 1.6	0.4 to 0.6
ERJ3G(0603)	0.7 to 0.9	2 to 2.2	0.8 to 1
ERJ6G(0805)	1 to 1.4	3.2 to 3.8	0.9 to 1.4
ERJ8G(1206)	2 to 2.4	4.4 to 5	1.2 to 1.8
ERJ14(1210)	2 to 2.4	4.4 to 5	1.8 to 2.8
ERJ12(1812)	3.3 to 3.7	5.7 to 6.5	2.3 to 3.5
ERJ12Z(2010)	3.6 to 4	6.2 to 7	1.8 to 2.8
ERJ1T(2512)	5 to 5.4	7.6 to 8.6	2.3 to 3.5

Recommended Soldering Conditions

Recommendations and precautions are described below.

Recommended soldering conditions for reflow

- Reflow soldering should be a maximum of two times
- Please contact us for additional information when used in conditions other than those specified.
- Please measure the temperature of terminations and study every type of printed circuit board for solderability, before actual use.

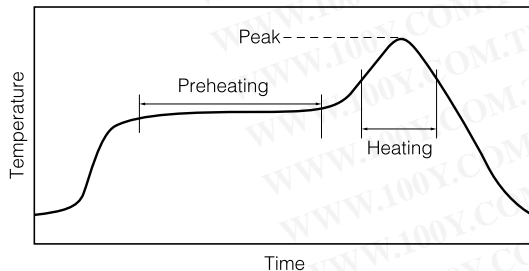

For soldering (Example : Sn/Pb)

	Temperature	Time
Preheating	140 °C to 160 °C	60 s to 120 s
Main heating	Above 200 °C	30 s to 40 s
Peak	235 ± 5 °C	max. 10 s

For lead-free soldering (Example : Sn/Ag/Cu)

	Temperature	Time
Preheating	150 °C to 180 °C	60 s to 120 s
Main heating	Above 230 °C	30 s to 40 s
Peak	max. 260 °C	max. 10 s

Recommended soldering conditions for flow

	For soldering		For lead-free soldering	
	Temperature	Time	Temperature	Time
Preheating	140 °C to 160 °C	60 s to 120 s	150 °C to 180 °C	60 s to 120 s
Soldering	245±5 °C	20 s to 30 s	max. 260 °C	max. 10 s

⚠ Safety Precautions

- If transient load (heavy load in a short time) like pulse is to be applied, carry out an evaluation and confirmation test with the resistors actually mounted on the board.
When a load of more than the rated power is applied under load condition at steady state, it may impair performance and/or reliability of the resistor.
Never exceed the specified rated power.
- Chlorine type or other highly-reactive flux is not recommended. Residue could affect performance or reliability of the resistors.
- When using a soldering iron, never let the tip of the iron touch the body of the chip resistor. When using a soldering iron with a tip at a high temperature, solder for as short time as possible (no more than three seconds and up to 350 °C).
- Avoid physical shock to the resistor and nipping of the resistor with hard tool (pliers or tweezers) as it may damage the protective coating of the resistor and may affect its performance.