

### Features

- NTSC, PAL and SECAM sync separation
- Single supply, +5V
- Precision 50% slicing, internal caps
- Built-in color burst filter
- Decodes non-standard verticals
- Pin compatible with LM1881
- Low power
- Typically 1.5 mA supply current
- Resistor programmable scan rate
- Few external components
- Available in 8-pin DIP and SO-8 pkg.

### Applications

- Video special effects
- Video test equipment
- Video distribution
- Displays
- Imaging
- Video data capture
- Video triggers

### Ordering Information

Part No.	Temp. Range	Package	Outline #
EL4581CN	-40°C to +85°C	8-Pin DIP	MDP0031
EL4581CS	-40°C to +85°C	8-Lead SO	MDP0027

### Demo Board

A dedicated demo board is not available. However, this device can be placed on the EL4584/5 Demo Board.

### General Description

The EL4581C extracts timing information from standard negative going video sync found in NTSC, PAL, and SECAM broadcast systems. It can also be used in non standard formats and with computer graphics systems at higher scan rates, by adjusting a single external resistor. When the input does not have correct serration pulses in the vertical interval, a default vertical output is produced.

Outputs are composite sync, vertical sync, burst/back porch output, and odd/even output. The later operates only in interlaced scan formats.

The EL4581C provides a reliable method of determining correct sync slide level by setting it to the mid-point between sync tip and blanking level at the back porch. This 50% level is determined by two internal self timing sample and hold circuits that track sync tip and back porch levels. This also provides a degree of hum and noise rejection to the input signal, and compensates for varying input levels of 0.5 p-p to 2.0 Vp-p.

A built in linear phase, third order, low pass filter attenuates the chroma signal in color systems to prevent incorrectly set color burst from disturbing the 50% sync slide.

This device may be used to replace the industry standard LM1881, offering improved performance and reduced power consumption.

The EL4581C video sync separator is manufactured using Elantec's high performance analog CMOS process.

### Connection Diagram

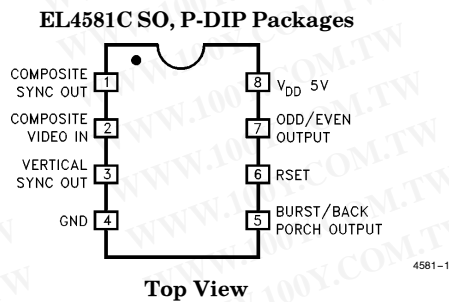

Manufactured under U.S. Patent No. 5,528,303

Note: All information contained in this data sheet has been carefully checked and is believed to be accurate as of the date of publication; however, this data sheet cannot be a "controlled document". Current revisions, if any, to these specifications are maintained at the factory and are available upon your request. We recommend checking the revision level before finalization of your design documentation.

# EL4581C

## Sync Separator, 50% Slice, S-H, Filter

### Absolute Maximum Ratings ( $T_A = 25^\circ\text{C}$ )

$V_{CC}$ Supply	7V	Pin Voltages	-0.5V to $V_{CC} + 0.5\text{V}$
Storage Temperature	-65°C to +150°C	Operating Temperature Range	-40°C to +85°C
Lead Temperature	260°C		

#### Important Note:

All parameters having Min/Max specifications are guaranteed. The Test Level column indicates the specific device testing actually performed during production and Quality inspection. Elantec performs most electrical tests using modern high-speed automatic test equipment, specifically the LTX77 Series system. Unless otherwise noted, all tests are pulsed tests, therefore  $T_J = T_C = T_A$ .

Test Level	Test Procedure
I	100% production tested and QA sample tested per QA test plan QCX0002.
II	100% production tested at $T_A = 25^\circ\text{C}$ and QA sample tested at $T_A = 25^\circ\text{C}$ , $T_{MAX}$ and $T_{MIN}$ per QA test plan QCX0002.
III	QA sample tested per QA test plan QCX0002.
IV	Parameter is guaranteed (but not tested) by Design and Characterization Data.
V	Parameter is typical value at $T_A = 25^\circ\text{C}$ for information purposes only.

### DC Electrical Characteristics Unless otherwise state $V_{DD} = 5\text{V}$ , $T_A = 25^\circ\text{C}$ , $R_{set} = 680\text{ k}\Omega$ .

Parameter	Description	Temp	Min	Typ	Max	Test Level	Units
$I_{DD}$	$V_{DD} = 5\text{V}$ (Note 1)	25°C	0.75	1.7	3	I	mA
Clamp Voltage	Pin 2, Unloaded	25°C	1.3	1.5	1.9	I	V
Discharge Current	Pin 2 = 2V	25°C	6	10	20	I	$\mu\text{A}$
Clamp Charge Current	Pin 2, $V_{IN} = 1\text{V}$	25°C	2	3		I	mA
Ref Voltage	Pin 6, $V_{DD} = 5\text{V}$ (Note 2)	25°C	1.5	1.8	2.1	I	V
$V_{OL}$ Output Low Voltage	$I_{OL} = 1.6\text{ mA}$	25°C			800	I	mV
$V_{OH}$ Output High Voltage	$I_{OH} = -40\ \mu\text{A}$ $I_{OH} = -1.6\text{ mA}$	25°C	4 2.4			IV I	V

Note 1: No video signal, outputs unloaded.

Note 2: Tested for  $V_{DD} 5\text{V} \pm 5\%$  which guarantees timing of output pulses over this range.

# EL4581C

## Sync Separator, 50% Slice, S-H, Filter

### Dynamic Characteristics

$V_{DD} = 5V$ ,  $I_V$  pk-pk video,  $T_A = 25^\circ C$ ,  $C_L = 15$  pF,  $I_{OH} = -1.6$  mA,  $I_{OL} = 1.6$  mA. Signal voltages are peak to peak.

Parameter	Description	Temp	Min	Typ	Max	Test Level	Units
Vertical Sync Width, $t_{VS}$	(Note 3)	25°C	190	230	300	I	$\mu s$
Burst/Back Porch Width, $t_B$	(Note 3)	25°C	2.5	3.5	4.5	I	$\mu s$
Vertical Sync Default Delay $t_{VSD}$		25°C	40	55	70	I	$\mu s$
Filter Attenuation	$F_{IN} = 3.4$ MHz (Note 4)	25°C		24		V	dB
Composite Sync Prop Delay	$V_{IN}$ – Composite Sync (Note 3)	25°C		260	400	I	ns
Input Dynamic Range	p-p NTSC Signal (Note 5)	25°C	0.5		2	I	V
Slice Level	Input Voltage = $1V_{P.P}$ (Note 6)	25°C	40%	50%	60%	I	
		Full	40%	50%	60%	IV	

Note 3: C/S, Vertical and Burst outputs are all active low –  $V_{OH} = 2.4V$ ,  $V_{OL} = 0.8V$ .

Note 4: Attenuation is a function of Rset (PIN6).

Note 5: Typical min. is  $0.3 V_{P.P}$ .

Note 6: Refers to threshold level of sync. tip to back porch amplitude.

### Pin Descriptions

Pin No.	Pin Name	Function
1	Composite Sync Out	Composite sync pulse output. Sync pulses start on a falling edge and end on a rising edge.
2	Composite Video in	AC coupled composite video input. Sync tip must be at the lowest potential (Positive picture phase).
3	Vertical Sync Out	Vertical sync pulse output. The falling edge of Vert Sync is the start of the vertical period.
4	GND	Supply ground.
5	Burst/Back Porch Output	Burst/Back porch output. Low during burst portion of composite video.
6	$R_{SET}$	An external resistor to ground sets all internal timing. 681k, 1% resistor will provide correct timing for NTSC signals.
7	Odd/Even Output	Odd/Even field output. Low during odd fields, high during even fields. Transitions occur at start of Vert Sync pulse.
8	$V_{DD} 5V$	Positive supply. (5V)

Note:  $R_{SET}$  must be a 1% resistor.

# EL4581C

## Sync Separator, 50% Slice, S-H, Filter

### Typical Performance Characteristics

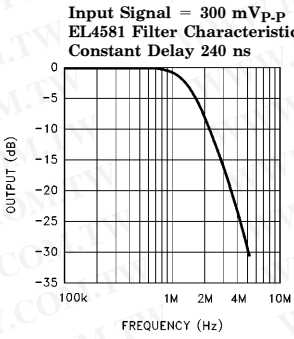
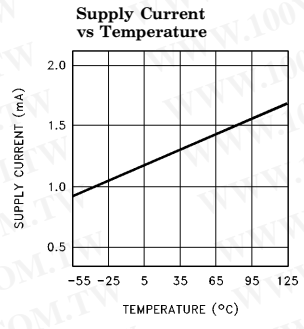
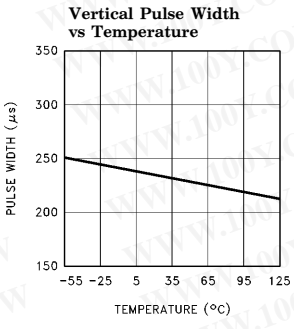
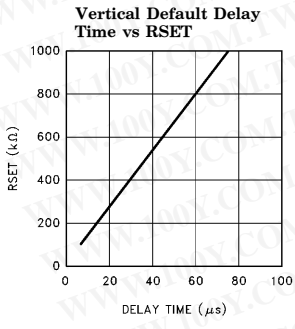
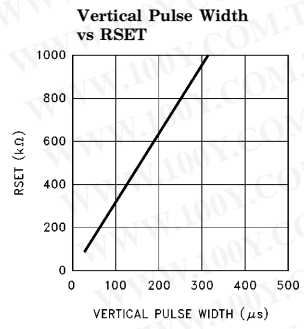
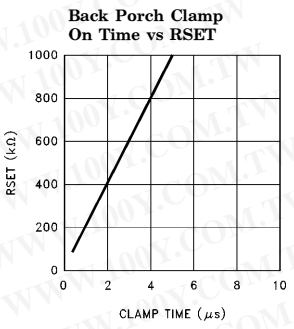
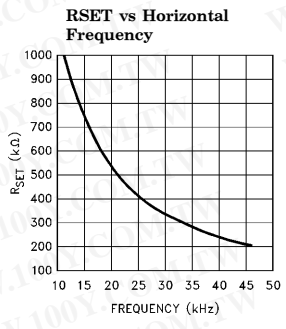

4581-2

# EL4581C

## Sync Separator, 50% Slice, S-H, Filter

### Timing Diagrams

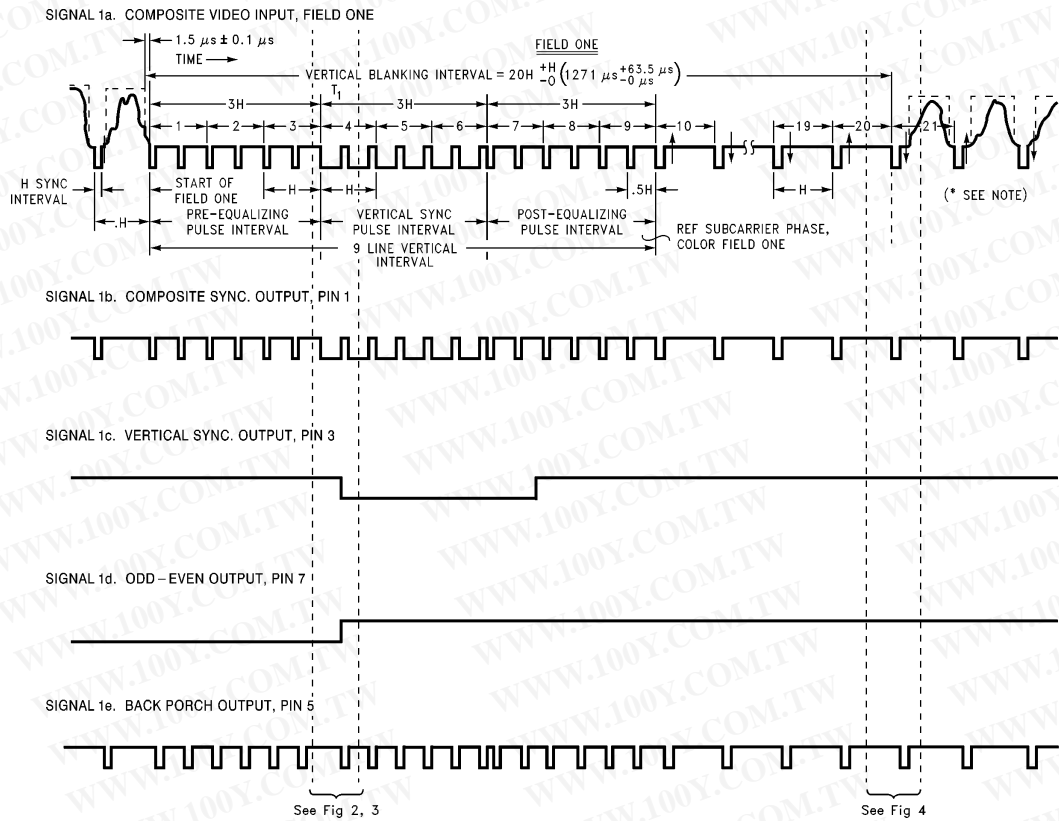

Figure 1

4581-3

Notes:

- b. The composite sync output reproduces all the video input sync pulses, with a propagation delay.
- c. Vertical sync leading edge is coincident with the first vertical serration pulse leading edge, with a propagation delay.
- d. Odd-even output is low for even field, and high for odd field.
- e. Back porch goes low for a fixed pulse width on the trailing edge of video input sync pulses. Note that for serration pulses during vertical, the back porch starts on the rising edge of the serration pulse (with propagation delay).

# EL4581C

## Sync Separator, 50% Slice, S-H, Filter

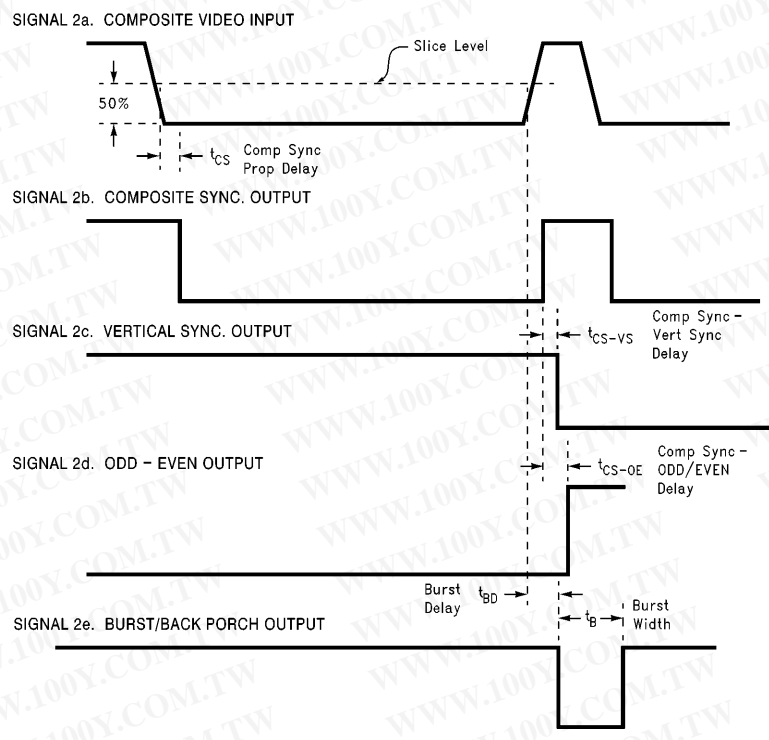

Figure 2

4581-5

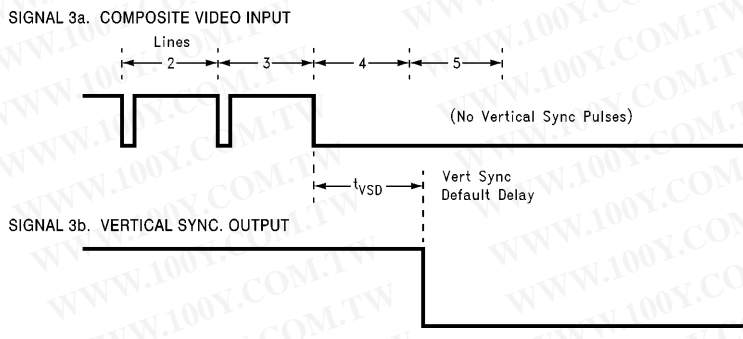

Figure 3

4581-6

# EL4581C

## Sync Separator, 50% Slice, S-H, Filter

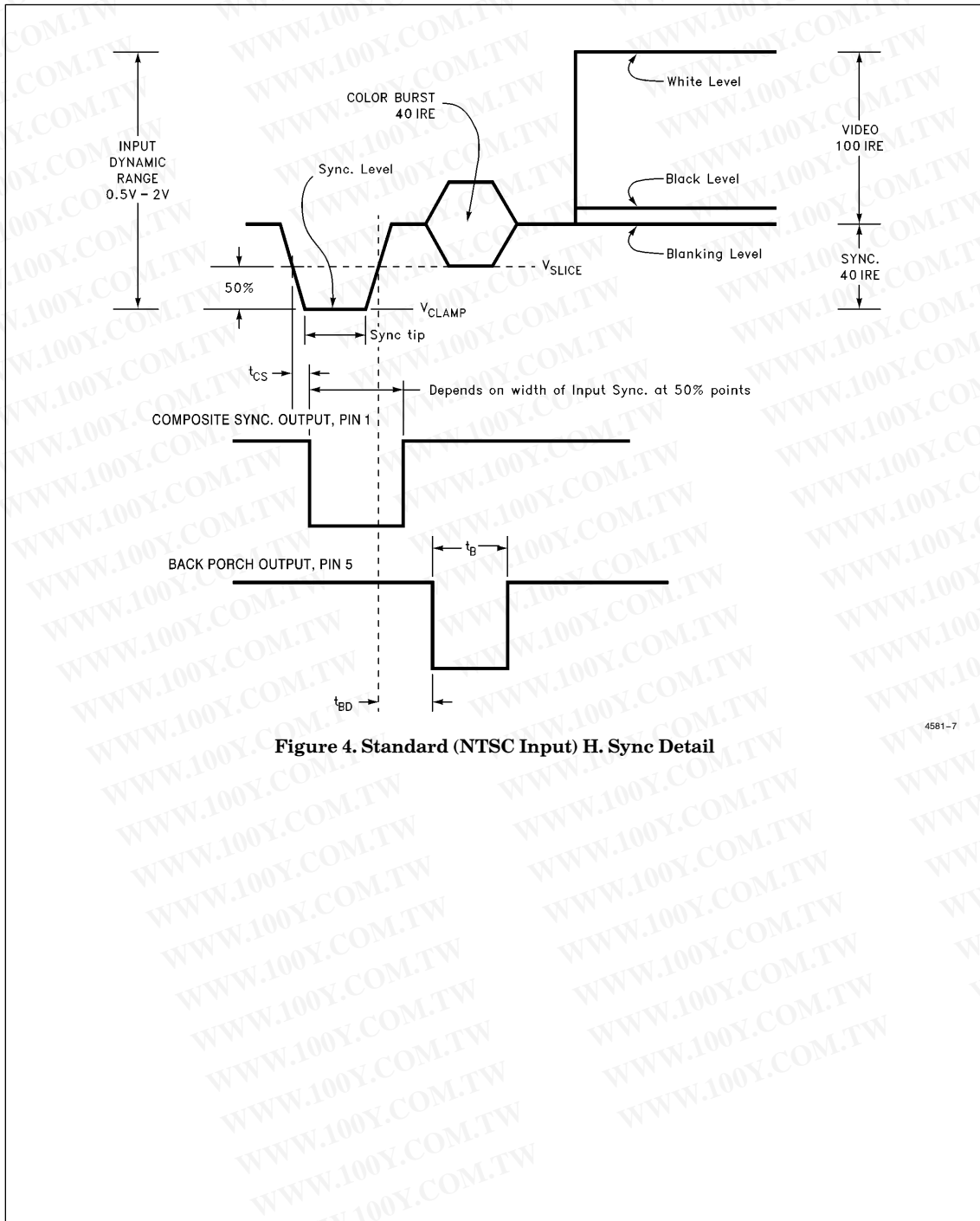

Figure 4. Standard (NTSC Input) H. Sync Detail

4581-7

# EL4581C

## Sync Separator, 50% Slice, S-H, Filter

### Description of Operation

A simplified block schematic is shown in Figure 2. The following description is intended to provide the user with sufficient information to be able to understand the effects that the external components and signal conditions have on the outputs of the integrated circuit.

The video signal is AC coupled to pin 2 via the capacitor  $C_1$ , nominally  $0.1 \mu\text{F}$ . The clamp circuit A1 will prevent the input signal on pin 2 going any more negative than  $1.5\text{V}$ , the value of reference voltage  $V_{R1}$ . Thus the sync tip, the most negative part of the video waveform, will be clamped at  $1.5\text{V}$ . The current source  $I_1$ , nominally  $10 \mu\text{A}$ , charges the coupling capacitor during the remaining portion of the H line, approximately  $58 \mu\text{s}$  for a  $15.75 \text{ kHz}$  timebase. From  $I \cdot t = C \cdot V$ , the video time-constant can be calculated. It is important to note that the charge taken from the capacitor during video must be replaced during the sync tip time, which is much shorter, (ratio of  $\times 12.5$ ). The corresponding current to restore the charge during sync will therefore be an order of magnitude higher, and any resistance in series with  $C_1$  will cause sync tip crushing. For this reason, the internal series resistance has been minimized and external high resistance values in series with the input coupling capacitor should be avoided. The user can exercise some control over the value of the input time constant by introducing an external pull-up resistance from pin 2 to the  $5\text{V}$  supply. The maximum voltage across the resistance will be  $V_{DD}$  less  $1.5\text{V}$ , for black level. For a net discharge current greater than zero, the resistance should be greater than  $450\text{k}$ . This will have the effect of increasing the time constant and reducing the degree of picture tilt. The current source  $I_1$  directly tracks reference current  $I_{TR}$  and thus increases with scan rate adjustment, as explained later.

The signal is processed through an active 3 pole filter (F1) designed for minimum ripple with constant phase delay. The filter attenuates the color burst by  $24 \text{ dB}$  and eliminates fast transient spikes without sync crushing. An external filter is not necessary. The filter also amplifies the

video signal by  $6 \text{ dB}$  to improve the detection accuracy. Note that the filter cut-off frequency is a function of RSET through  $I_{OT}$  and is proportional to  $I_{OT}$ .

Internal reference voltages (block  $V_{REF}$ ) with high immunity to supply voltage variation are derived on the chip. Reference  $V_{R4}$  with op-amp A2 forces pin 6 to a reference voltage of  $1.7\text{V}$  nominal. Consequently, it can be seen that the external resistance RSET will determine the value of the reference current  $I_{TR}$ . The internal resistance R3 is only about  $6 \text{ k}\Omega$ , much less than RSET. All the internal timing functions on the chip are referenced to  $I_{TR}$  and have excellent supply voltage rejection.

Comparator C2 on the input to the sample and hold block (S/H) compares the leading and trailing edges of the sync. pulse with a threshold voltage  $V_{R2}$  which is referenced at a fixed level above the clamp voltage  $V_{R1}$ . The output of C2 initiates the timing one-shots for gating the sample and hold circuits. The sample of the sync tip is delayed by  $0.8 \mu\text{s}$  to enable the actual sample of  $2 \mu\text{s}$  to be taken on the optimum section of the sync. pulse tip. The acquisition time of the circuit is about three horizontal lines. The double poly CMOS technology enables long time constants to be achieved with small high quality on-chip capacitors. The back porch voltage is similarly derived from the trailing edge of sync, which also serves to cut off the tip sample if the gate time exceeds the tip period. Note that the sample and hold gating times will track RSET through  $I_{OT}$ .

The  $50\%$  level of the sync tip is derived, through the resistor divider R1 and R2, from the sample and held voltages  $V_{TIP}$  and  $V_{BP}$ , and applied to the plus input of comparator C1. This comparator has built in hysteresis to avoid false triggering. The output of C2 is a digital  $5\text{V}$  signal which feeds the C/S output buffer B1 and the other internal circuit blocks, the vertical, back porch and odd/even functions.

The vertical circuit senses the C/S edges and initiates an integrator which is reset by the shorter horizontal sync pulses but times out the longer

# EL4581C

## Sync Separator, 50% Slice, S-H, Filter

### Description of Operation — Contd.

vertical sync. pulse widths. The internal timing circuits are referenced to  $I_{OT}$  and  $V_{R3}$ , the time-out period being inversely proportional to the timing current. The vertical output pulse is started on the first serration pulse in the vertical interval and is then self-timed out. In the absence of a serration pulse, an internal timer will default the start of vertical.

The back porch is triggered from the sync tip trailing edge and initiates a one-shot pulse. The period of this pulse is again a function of  $I_{OT}$  and will therefore track the scan rate set by RSET.

The odd/even circuit (O/E) comprises of flip flops which track the relationship of the horizontal pulses to the leading edge of the vertical output, and will switch on every field at the start of vertical. Pin 7 is high during the odd field.

Loss of video signal can be detected by monitoring the C/S output. The 50% level of the previous video signal will remain held on the S/H capacitors after the input video signal has gone and the input on pin 2 has defaulted to the clamp voltage. Consequently the C/S output will remain low longer than the normal vertical pulse period. An external timing circuit could be used to detect this condition.

### Block Diagram

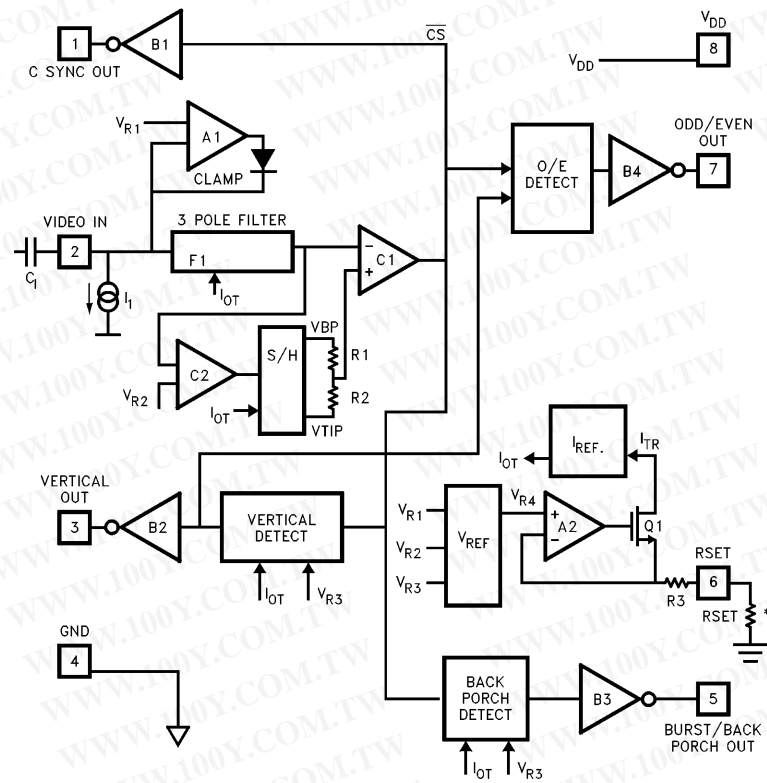

Figure 5

\*Note: RSET must be a 1% resistor.

4581-4