

Features

- Fully differential inputs, outputs, and feedback
- Differential input range $\pm 2.3V$
- 150 MHz 3 dB bandwidth
- 800 V/ μs slew rate
- - 55 dB distortion at 3 MHz
- - 75 dB distortion at 100 kHz
- $\pm 5V$ supplies or +6V single supply
- 50 mA minimum output current
- Output swing (200 Ω load) to within 1.5V of supplies (14V pk-pk differential)
- Low power-11 mA typical supply current

Applications

- Twisted pair driver
- Differential line driver
- VGA over twisted pair
- ADSL/HDSL driver
- Single ended to differential amplification
- Transmission of analog signals in a noisy environment

Ordering Information

Part No.	Temp. Range	Package	Outline #
EL2140CN	-40°C to +85°C	8-pin PDIP	MDP0031
EL2140CS	-40°C to +85°C	8-pin SOIC	MDP0027
EL2141CN	-40°C to +85°C	8-pin PDIP	MDP0031
EL2141CS	-40°C to +85°C	8-pin SOIC	MDP0027

General Description

The EL2140C/2141C is a very high bandwidth amplifier whose output is in differential form, and is thus primarily targeted for applications such as driving twisted pair lines, or any application where common mode injection is likely to occur. The input signal can be in either single-ended or differential form, but the output is always in differential form.

On the EL2141C, two feedback inputs provide the user with the ability to set the device gain, (stable at minimum gain of two), whereas the EL2140C comes with a fixed gain of two.

The output common mode level is set by the reference pin (V_{REF}), which has a -3 dB bandwidth of over 100 MHz. Generally, this pin is grounded, but it can be tied to any voltage reference.

The transmission of ADSL/HDSL signals requires very low distortion amplification, so this amplifier was designed with this as a primary goal. The actual signal distortion levels depend upon input and output signal amplitude, as well as the output load impedance. (See distortion data inside.)

Both outputs (V_{OUT} , V_{OUTB}) are short circuit protected to withstand temporary overload condition.

Connection Diagrams

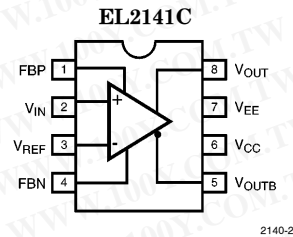
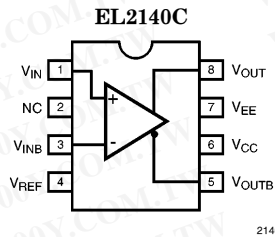

Note: All information contained in this data sheet has been carefully checked and is believed to be accurate as of the date of publication; however, this data sheet cannot be a "controlled document". Current revisions, if any, to these specifications are maintained at the factory and are available upon your request. We recommend checking the revision level before finalization of your design documentation.

勝特力材料 886-3-5753170
 勝特力电子(上海) 86-21-54151736
 勝特力电子(深圳) 86-755-83298787
 Http://www.100y.com.tw

EL2140C/2141C

150 MHz Differential Twisted Pair Driver

Absolute Maximum Ratings

Supply Voltage ($V_{CC}-V_{EE}$)	0V–12.6V	Recommended Operating Temperature	–40°C to 85°C
Maximum Output Current	±60 mA	V_{IN} , V_{INB} , V_{REF}	$V_{EE} + 0.8V$ (MIN) to $V_{CC} - 0.8V$ (MAX)
Storage Temperature Range	–65°C to +150°C	$V_{IN}-V_{INB}$	±5V
Operating Junction Temperature	+150°C		

Important Note:

All parameters having Min/Max specifications are guaranteed. The Test Level column indicates the specific device testing actually performed during production and Quality inspection. Elantec performs most electrical tests using modern high-speed automatic test equipment, specifically the LTX77 Series system. Unless otherwise noted, all tests are pulsed tests, therefore $T_J = T_C = T_A$.

Test Level	Test Procedure
I	100% production tested and QA sample tested per QA test plan QCX0002.
II	100% production tested at $T_A = 25^\circ\text{C}$ and QA sample tested at $T_A = 25^\circ\text{C}$, T_{MAX} and T_{MIN} per QA test plan QCX0002.
III	QA sample tested per QA test plan QCX0002.
IV	Parameter is guaranteed (but not tested) by Design and Characterization Data.
V	Parameter is typical value at $T_A = 25^\circ\text{C}$ for information purposes only.

DC Electrical Characteristics

$V_{CC} = +5V$, $V_{EE} = -5V$, $T_A = 25^\circ\text{C}$, $V_{IN} = 0V$, $R_L = 200$, unless otherwise specified

Parameter	Description	Min	Typ	Max	Test Level	Units
V_{supply}	Supply Operating Range ($V_{CC}-V_{EE}$)	±3.0	±5.0	±6.3	I	V
I_S	Power Supply Current (No Load)		11	14	I	mA
V_{OS}	Input Referred Offset Voltage	–25	10	40	I	mV
I_{IN}	Input Bias Current (V_{IN} , V_{INB} , V_{REF})	–20	6	20	I	μA
Z_{IN}	Differential Input Impedance		400		V	kΩ
V_{DIFF}	Differential Input Range	±2.0	±2.3		I	V
A_V	Voltage Gain (EL2140C) $V_{IN} = 2V_{pk-pk}$	1.95	1.985	2.02	I	V/V
A_{VOL}	Open Loop Voltage Gain (EL2141C)		75		V	dB
V_{CM}	Input Common Mode Voltage Range (EL2140C)	–2.6		+4.0	I	V
$V_{OUT(200)}$	Output Voltage Swing (200Ω load, V_{OUT} to V_{OUTB}) (EL2141C)	±3.4	±3.6		I	V
$V_{OUT(100)}$	Output Voltage Swing (100Ω Load, V_{OUT} to V_{OUTB}) (EL2141C)	±2.9	±3.1		I	V
V_N	Input Referred Voltage Noise		36		V	nV/√ Hz
V_{REF}	Output Voltage Control Range (EL2140C)	–2.5		+3.3	I	V
V_{REFOS}	Output Offset Relative to V_{REF}	–60	–25	+60	I	mV
PSRR	Power Supply Rejection Ratio	60	70		I	dB
$I_{OUT(min)}$	Minimum Output Current	50	60		I	mA
CMRR	Input Common Mode Rejection Ratio (EL2140C) $V_{CM} = \pm 2V$	60	70		I	dB
R_{OUT}	($V_{OUT} = V_{OUTB} = 0V$) Output Impedance		0.1		V	Ω

EL2140C/2141C

150 MHz Differential Twisted Pair Driver

AC Electrical Characteristics

$V_{CC} = +5V$, $V_{EE} = -5V$, $T_A = 25^\circ C$, $V_{IN} = 0V$, $R_{LOAD} = 200$, unless otherwise specified

Parameter	Description	Min	Typ	Max	Test Level	Units
BW(-3 dB)	-3 dB Bandwidth (EL2140C and EL2141C @ gain of 2)		150		V	MHz
SR	Differential Slewrate		800		V	V/ μ s
Tstl	Settling Time to 1%		15		V	ns
GBW	Gain Bandwidth Product		400		V	MHz
$V_{REFBW}(-3\text{ dB})$	V_{REF} -3 dB Bandwidth		130		V	MHz
V_{REFSR}	V_{REF} Slewrate		100		V	V/ μ s
THDf1	Distortion at 100 kHz (Note 1)		-75		V	dB
dP	Differential Phase @ 3.58 MHz		0.16		V	°
dG	Differential Gain @ 3.58 MHz		0.24		V	%

Note 1: Distortion measurement quoted for $V_{OUT} - V_{OUTB} = 12V$ pk-pk, $R_{LOAD} = 200\Omega$, $V_{gain} = 8$.

Pin Description

Pin No.		Pin Name	Function
EL2140C	EL2141C		
1	2	V_{IN}	Non-inverting Input
3		V_{INB}	Inverting Input (EL2140C only)
	1	FBP	Non-inverting Feedback Input. Resistor R1 must be Connected from this Pin to V_{OUT} . (EL2141C only)
	4	FBN	Inverting Feedback Input. Resistor R3 must be Connected from this pin to V_{OUTB} . (EL2141C only)
4	3	V_{REF}	Output Common-mode Control. The Common-mode Voltage of V_{OUT} and V_{OUTB} will Follow the Voltage on this Pin. Note that on the EL2141, this pin is also the V_{INB} pin.
5	5	V_{OUTB}	Inverting Output
6	6	V_{CC}	Positive Supply
7	7	V_{EE}	Negative Supply
8	8	V_{OUT}	Non-inverting Output

勝特力材料 886-3-5753170
 勝特力电子(上海) 86-21-54151736
 勝特力电子(深圳) 86-755-83298787
[Http://www.100y.com.tw](http://www.100y.com.tw)

EL2140C/2141C

150 MHz Differential Twisted Pair Driver

Typical Performance Curves

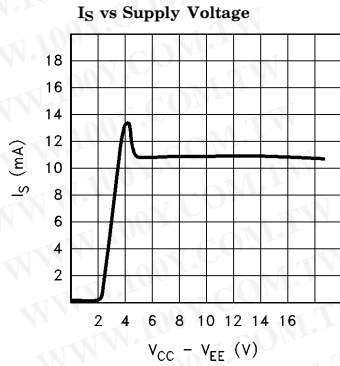

2140-3

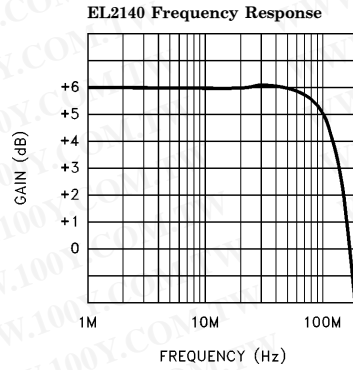

2140-4

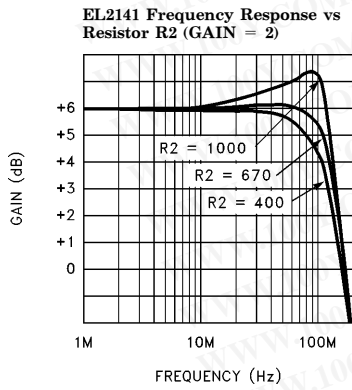

2140-5

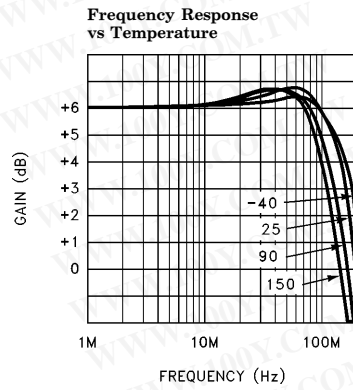

2140-6

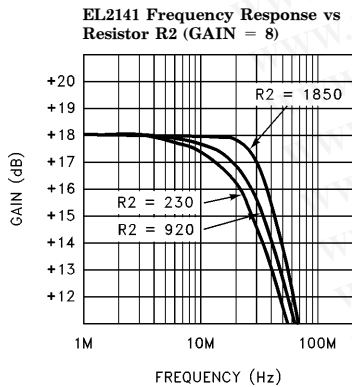

2140-7

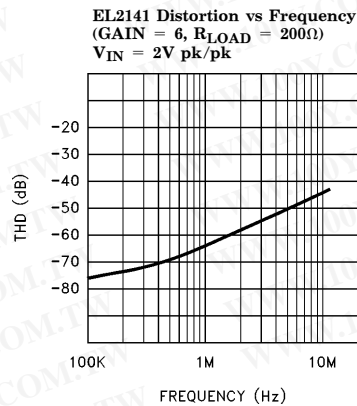

2140-8

勝特力材料 886-3-5753170
 勝特力电子(上海) 86-21-54151736
 勝特力电子(深圳) 86-755-83298787
[Http://www.100y.com.tw](http://www.100y.com.tw)

EL2140C/2141C

150 MHz Differential Twisted Pair Driver

Typical Performance Curves — Contd.

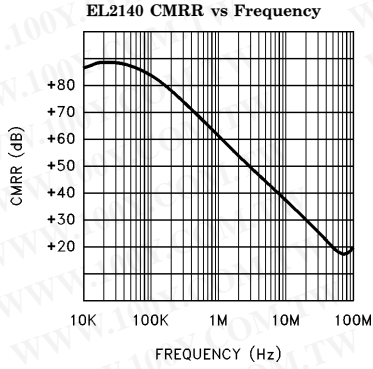

2140-9

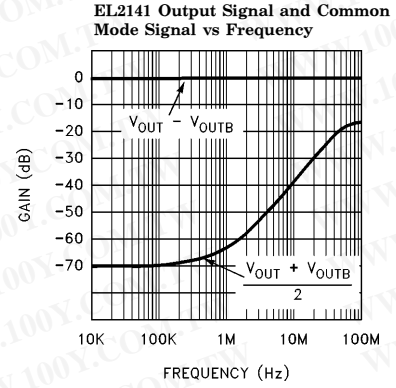

2140-10

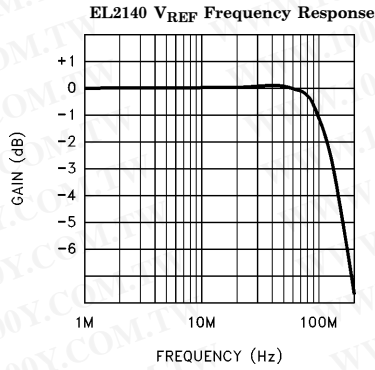

2140-11

勝特力材料 886-3-5753170
 勝特力电子(上海) 86-21-54151736
 勝特力电子(深圳) 86-755-83298787
[Http://www.100y.com.tw](http://www.100y.com.tw)

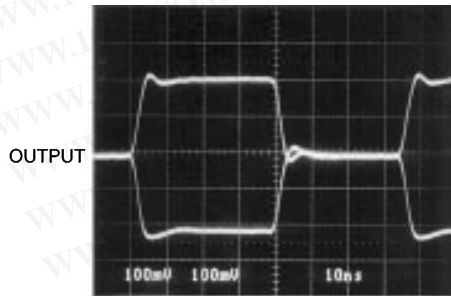

2140-12

EL2140 Small Signal Response (Note 1)

Note 1: Photo shows voltages on a 100Ω transmission line terminated at both ends, so voltages at V_{OUT} , V_{OUTB} are twice the values shown.

EL2140C/2141C

150 MHz Differential Twisted Pair Driver

Applications Information

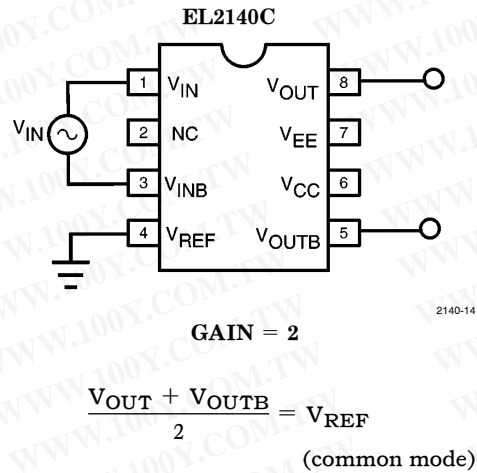
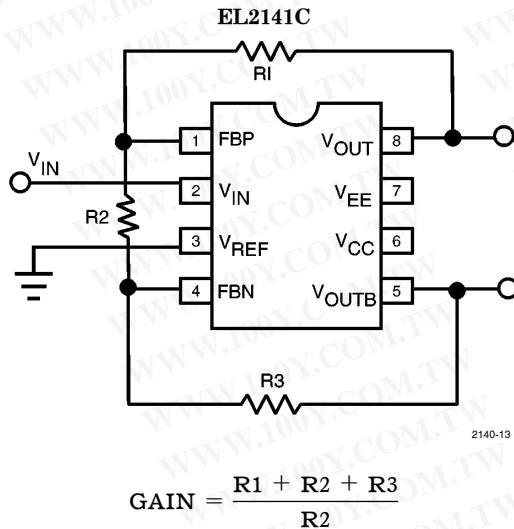

Choice of feedback resistor

There is little to be gained from choosing resistor R2 values below 400Ω and, in fact, it would only result in increased power dissipation and signal distortion. Above 400Ω, the bandwidth response will develop some peaking (for a gain of two), but substantially higher resistor R2 values may be used for higher voltage gains, such as up to 2 kΩ at a gain of eight before peaking will develop. R1 and R3 are selected as needed to set the voltage gain, and while R1 = R3 is suggested, the gain equation above holds for any values (see distortion for further suggestions).

Capacitance considerations

As with many high bandwidth amplifiers, the EL2140C/2141C prefer not to drive highly capacitive loads. It is best if the capacitance on V_OUT and V_OUTB is kept below 10 pF if the user does not want gain peaking to develop.

In addition, on the EL2141C, the two feedback nodes FBP and FBN should be laid out so as to minimize stray capacitance, else an additional pole will potentially develop in the response with possible gain peaking.

The amount of capacitance tolerated on any of these nodes in an actual application will also be dependent on the gain setting and the resistor values in the feedback network.

Distortion considerations

The harmonics that these amplifiers will potentially produce are the 2nd, 3rd, 5th, and 6th. Their amplitude is application dependent. All other harmonics should be negligible by comparison. Each should be considered separately:

H2 The second harmonic arises from the input stage, and the lower the applied differential signal amplitude, the lower the magnitude of the second harmonic. For practical considerations of required output signal and input noise levels, the user will end up choosing a circuit gain. Referring to Figure 1, it is best if the voltage at the negative feedback node tracks the V_REF node, and the voltage at the positive feedback node tracks the V_IN node respectively. This would theoretically require that R1 + R2 = R3, although the lowest distortion is found at about R3 = R1 + (0.7*R2). With this arrangement, the second harmonic should be suppressed well below the value of the third harmonic.

EL2140C/2141C

150 MHz Differential Twisted Pair Driver

Applications Information — Contd.

H3 The third harmonic should be the dominant harmonic and is primarily affected by output load current which, of course, is unavoidable. However, this should encourage the user not to waste current in the gain setting resistors, and to use values that consume only a small proportion of the load current, so long as peaking does not occur. The more load current, the worse the distortion, but depending on the frequency, it may be possible to reduce the amplifier gain so that there is more internal gain left to cancel out any distortion.

H5 The fifth harmonic should always be below the third, and will not become significant until heavy load currents are drawn. Generally, it should respond to the same efforts applied to reducing the third harmonic.

H6 The sixth harmonic should not be a problem and is the result of poor power supply decoupling. While 100 nF chip capacitors may be sufficient for some applications, it would be insufficient for driving full signal swings into a twisted pair line at 100 kHz. Under these conditions, the addition of 4.7 μ F tantalum capacitors would cure the problem.

Typical Applications Circuits

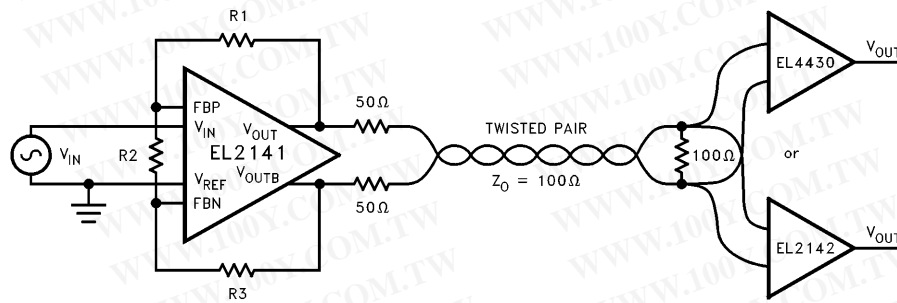

Figure 1. Typical Twisted Pair Application

2140-15

勝特力材料 886-3-5753170
勝特力电子(上海) 86-21-54151736
勝特力电子(深圳) 86-755-83298787
[Http://www.100y.com.tw](http://www.100y.com.tw)

EL2140C/2141C

150 MHz Differential Twisted Pair Driver

Typical Applications Circuits — Contd.

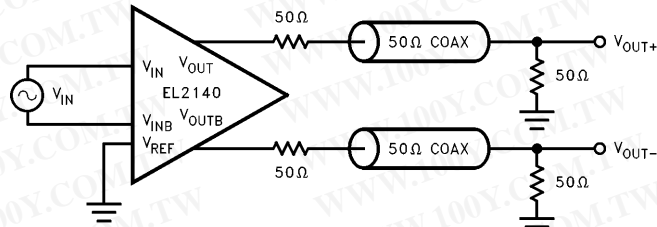

2140-16

Figure 2. Dual Coaxial Cable Driver

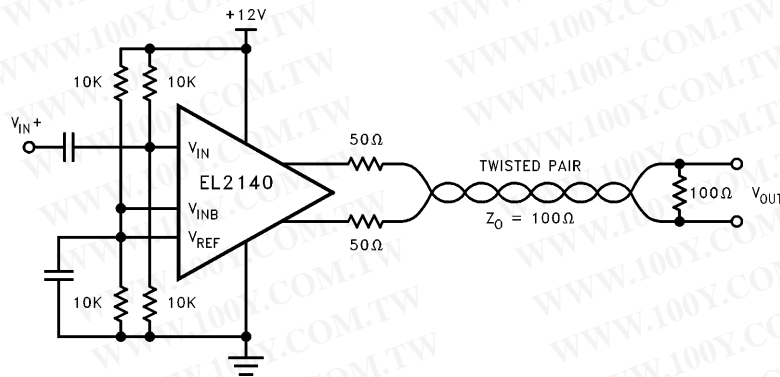

2140-17

Figure 3. Single Supply Twisted Pair Driver

勝特力材料 886-3-5753170
 勝特力电子(上海) 86-21-54151736
 勝特力电子(深圳) 86-755-83298787
[Http://www.100y.com.tw](http://www.100y.com.tw)

EL2140C/2141C

150 MHz Differential Twisted Pair Driver

Typical Applications Circuits — Contd.

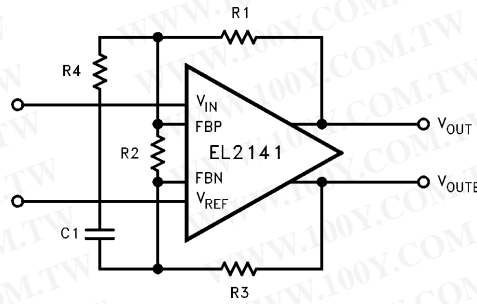

Figure 4. Differential Line Driver with Equalization

$$\text{DC Gain} = \frac{R1 + R2 + R3}{R2} \quad (\text{See Figure 5})$$

$$\text{HF Gain} = \frac{R1 + (R2//R4) + R3}{(R2//R4)} \quad (\text{See Figure 5})$$

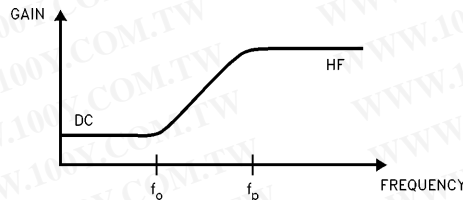

Figure 5

$$\text{where } f_o = \frac{1}{2 \pi C_1 R_2}$$

$$\text{and } f_p = \frac{1}{2 \pi C_1 R_4}$$

EL2140C/2141C

150 MHz Differential Twisted Pair Driver

Typical Applications Circuits — Contd.

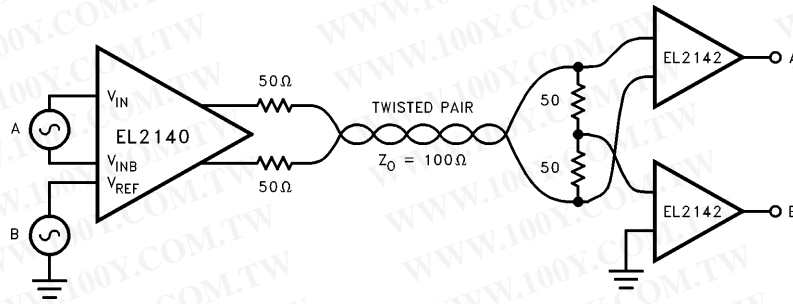

2140-20

Figure 6. Dual Signal Transmission Circuit

勝特力材料 886-3-5753170
勝特力电子(上海) 86-21-54151736
勝特力电子(深圳) 86-755-83298787
[Http://www.100y.com.tw](http://www.100y.com.tw)

勝特力材料 886-3-5753170
勝特力电子(上海) 86-21-54151736
勝特力电子(深圳) 86-755-83298787
[Http://www.100y.com.tw](http://www.100y.com.tw)

EL2140C/2141C

150 MHz Differential Twisted Pair Driver

勝特力材料 886-3-5753170
勝特力电子(上海) 86-21-54151736
勝特力电子(深圳) 86-755-83298787
[Http://www.100y.com.tw](http://www.100y.com.tw)

General Disclaimer

Specifications contained in this data sheet are in effect as of the publication date shown. Elantec, Inc. reserves the right to make changes in the circuitry or specifications contained herein at any time without notice. Elantec, Inc. assumes no responsibility for the use of any circuits described herein and makes no representations that they are free from patent infringement.

élantec
HIGH PERFORMANCE ANALOG INTEGRATED CIRCUITS

Elantec, Inc.
1996 Tarob Court
Milpitas, CA 95035
Telephone: (408) 945-1323
(800) 333-6314
Fax: (408) 945-9305
European Office: 44-71-482-4596

WARNING — Life Support Policy

Elantec, Inc. products are not authorized for and should not be used within Life Support Systems without the specific written consent of Elantec, Inc. Life Support systems are equipment intended to support or sustain life and whose failure to perform when properly used in accordance with instructions provided can be reasonably expected to result in significant personal injury or death. Users contemplating application of Elantec, Inc. products in Life Support Systems are requested to contact Elantec, Inc. factory headquarters to establish suitable terms & conditions for these applications. Elantec, Inc.'s warranty is limited to replacement of defective components and does not cover injury to persons or property or other consequential damages.