

SL-series solid state output relay

- Plug-in output relay for AC loads
- 3 A continuous current, 90 A/20 ms
- 0...240 VAC nominal load voltage
- Near zero leakage current
- Works correctly from zero load upwards
- Power factor independent (0...1)
- Immune to disturbances on signal or load lines
- Shielded signal cabling not required
- cULus General Use & Pilot Duty tested
- CE (EMC and LVD tested)
- Not for motor loads

勝特力材料 886-3-5753170
 勝特力电子(上海) 86-21-54151736
 勝特力电子(深圳) 86-755-83298787
[Http://www.100y.com.tw](http://www.100y.com.tw)

Block diagram

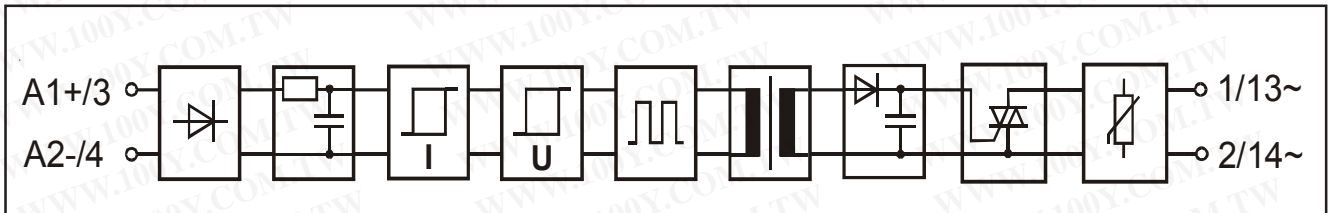

Specifications (at temperature of 25 °C)

Primary

Input voltage	nominal	24 VDC
Input current at nominal voltage	typical	15 mA
	maximum	17 mA
Input voltage range (abs.)	minimum	18 VDC
	maximum	32 VDC
Input impedance	typical	1,4 kΩ
Switch-on voltage	typical	16 VDC
	maximum	18 VDC
Switch-off voltage	typical	14 VDC
	minimum	12 VDC

Secondary

Load voltage	minimum	0 VAC
	nominal	240 VAC
	maximum	265 VAC
Load current	maximum	3 A
Load current 20 ms	maximum	90 A
Voltage drop at max. load	typical	1 V
Output leakage	typical	50 µA
Switch-on delay	typical	0,5 ms
	maximum	1 ms
Switch-off delay	maximum	11 ms
Load power factor, cos φ		0...1
dV/dt off-state	typical	4000 V/µs

Physical dimensions and other data

Breakdown voltage	minimum	4000 VAC rms
Resistance	minimum	10 ¹⁰ Ω
Material of casing		thermoplastic
Weight	typical	40 g
Air/creepage distance	minimum	8 mm
Capacitance I/O	typical	3 pF

Color of casing: black

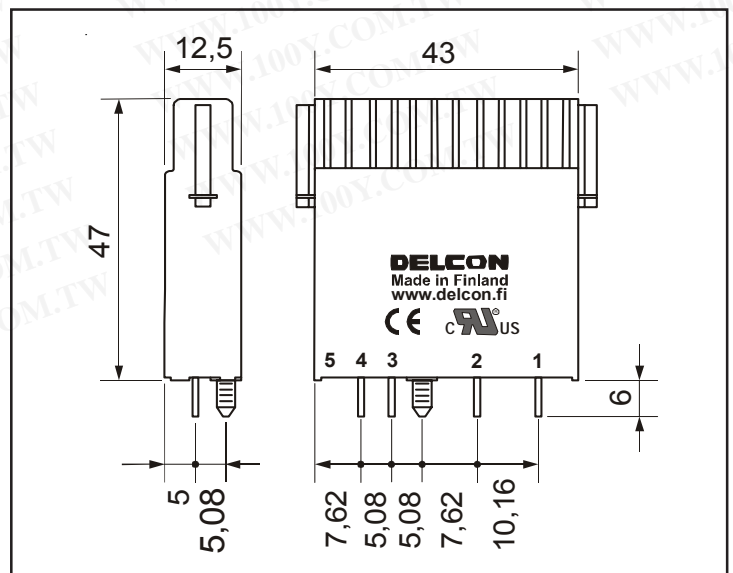

Dimensions in mm.

Temperature derating

Allowed load is derated to 1/3 linearly from +30 °C to +70 °C ambient temperature. When relays are mounted in mounting base the maximum load current for long period of time should be restricted in total to 50 % of the current from the curve. I.e. all relays at 50 % load continuously or 50 % of the relays at 100 % load continuously or all relays at 100 % load 50 % of the time. This restriction does not apply if there is at least 12,5 mm gap between relays.

Temperature range:

Storage: -40 °C...+70 °C
Operation: -10 °C...+70 °C

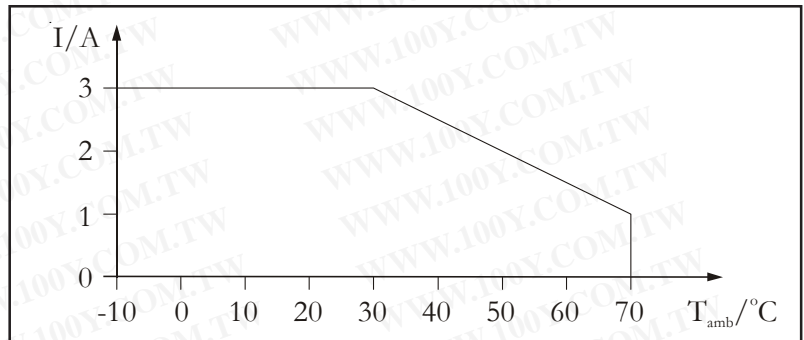

Derating curve for the relay.

Derating when switching inductive loads

There is no need to derate solid state output relay using a triac switch. The relay is indifferent to the power factor of the load. Calculation should be made however that the surge current does not exceed the specification. For reasons of heat dissipation, when the load will be switched frequently, the average current over a reasonable time should not exceed the specification for continuous operation.

Fusing

To protect relay against short circuit and overload a fast fuse with the correct rating for the load and the capacity of the relay should be chosen, for instance from the Wickman 193 range. Note that when overload current is not large it is possible that the fuse will not protect the relay because of the tolerance on the fuse rating.

Approvals



UL-file E 162828

勝特力材料 886-3-5753170
勝特力电子(上海) 86-21-54151736
勝特力电子(深圳) 86-755-83298787
[Http://www.100y.com.tw](http://www.100y.com.tw)



The relay fulfils EMC-directive 89/336/EEC requirements. Product has been tested according generic standards EN50081-2 and EN50082-2. The relay fulfils also requirements of the low voltage directive 73/23/EEC.

Guarantee

The solid state I/O relays and accessories made by Delcon Oy are guaranteed free from design and manufacturing defects for a period of three years from the shipping date. For electromechanical relays the guarantee is one year. The guarantee liability is limited to replacement of defective material and related shipping charges. Defective products must be returned to the factory for evaluation. This guarantee does not cover damage due to incorrect use or electrical overload.