

- Plug-in output relay for DC loads
- Switches up to 1 kHz signals
- 1,8 A continuous current, 12 A/10 ms
- 0...250 VDC nominal load voltage
- Integrated status LED
- Works correctly from zero load upwards
- For resistive and highly inductive loads
- Immune to disturbances on signal lines
- Shielded signal cabling not required
- cULus standard and pilot duty tested (UL and CSA)
- CE (EMC and LVD tested)
- Use a clamp diode with extremely inductive loads

勝特力材料 886-3-5753170  
 勝特力电子(上海) 86-21-54151736  
 勝特力电子(深圳) 86-755-83298787  
[Http://www.100y.com.tw](http://www.100y.com.tw)

### Block diagram

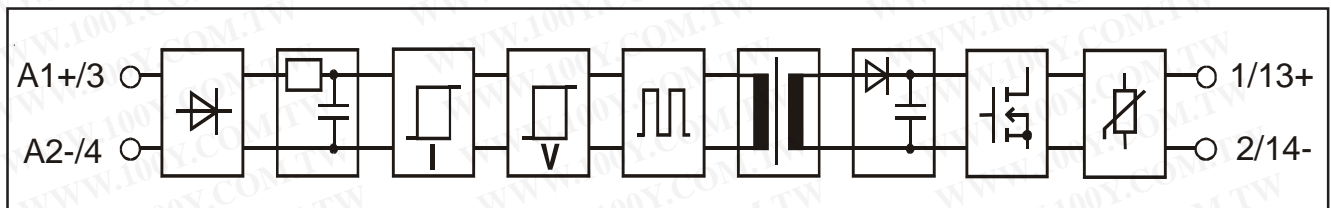

### Specifications (at temperature of 25 °C)

#### Primary

Input voltage	nominal	12 VDC
Input current at nominal voltage	typical	9 mA
	maximum	12 mA
Input voltage range (abs.)	minimum	9 VDC
	maximum	18 VDC
Input impedance	typical	1,3 kΩ
Switch-on voltage	typical	8 VDC
	maximum	9 VDC
Switch-off voltage	typical	7 VDC
	minimum	6 VDC

#### Secondary

Load voltage	minimum	0 VDC
	nominal	250 VDC
	maximum	300 VDC
Load current	typical	12 A
	maximum	1,8 A
Load current 10 ms	maximum	12 A
Voltage drop at max. load	typical	1,5 V
Switch-on delay	typical	0,3 ms
	maximum	0,5 ms
Switch-off delay	typical	0,3 ms
	maximum	0,5 ms
Inductive load, L/R	maximum	10 ms (250 V/1,8 A)
	maximum	100 ms (24 V/1,8 A)

### Physical dimensions and other data

Breakdown voltage	minimum	4000 VAC rms
Resistance	minimum	10 <sup>10</sup> Ω
Material of casing	thermoplastic	UL 94 V-0
Weight	typical	40 g
Air/creepage distance	minimum	8 mm
Capacitance I/O	typical	3 pF

Color of casing: red

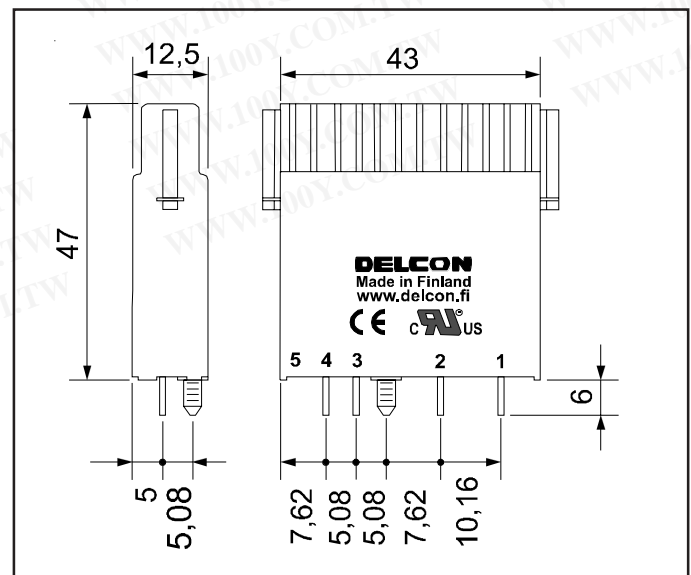

Dimensions in mm.

## Temperature derating

Allowed load is derated to 1/3 linearly from +30 °C to +70 °C ambient temperature. When relays are mounted together as a bank the maximum load current for long period of time should be restricted in total to 50 % of the current from the curve. I.e. all relays at 50 % load continuously or 50 % of the relays at 100 % load continuously or all relays at 100 % load 50 % of the time. This restriction does not apply if there is at least 12,5 mm gap between relays.

### Temperature range:

Storage: -40 °C...+70 °C  
 Operation: -25 °C...+70 °C

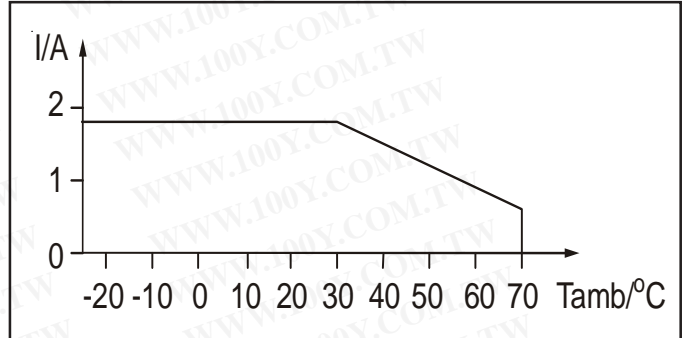

Derating curve for the relay.

## Derating when switching inductive loads

This relay is ment for resistive and inductive loads. A clamp diode must be used when switching extremely inductive loads. The surge current is not allowed to exceed the specification. For reasons of heat dissipation, when the load will be switched frequently, the average current over a reasonable time should not exceed the specification for continuous operation.

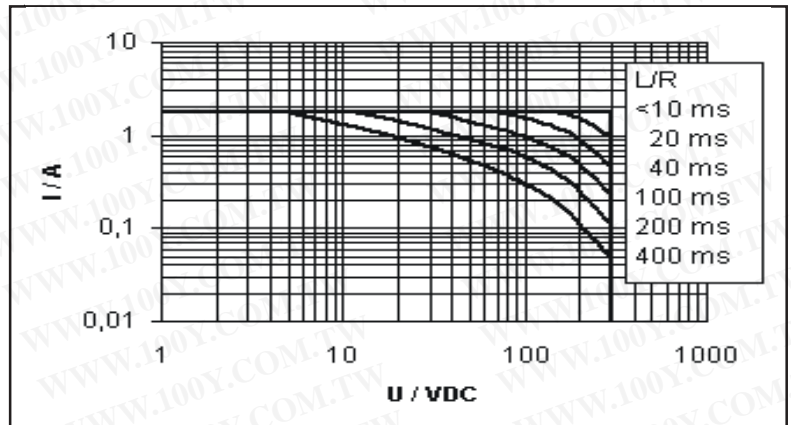

Derating curve for inductive loads.

## Fusing

To protect relay against short circuit and overload a fast fuse with the correct rating for the load and the capacity of the relay should be chosen, for instance from the Wickman 193 range. Note that when overload current is not large it is possible that the fuse will not protect the relay because of the tolerance on the fuse rating.

## Approvals



UL-file E 162828



The relay fulfils EMC-directive 89/336/EEC requirements. Product has been tested according generic standards EN50081-2 and EN50082-2. The relay fulfils also requirements of the low voltage directive 73/23/EEC.

## Guarantee

The solid state I/O relays and accessories made by Delcon Oy are guaranteed free from design and manufacturing defects for a period of three years from the shipping date. For electromechanical relays the guarantee is one year. The guarantee liability is limited to replacement of defective material and related shipping charges. Defective products must be returned to the factory for evaluation. This guarantee does not cover damage due to incorrect use or electrical overload.

勝特力材料 886-3-5753170  
 勝特力电子(上海) 86-21-54151736  
 勝特力电子(深圳) 86-755-83298787  
[Http://www.100y.com.tw](http://www.100y.com.tw)