

CR1225

3V Lithium Battery
Swiss Made

勝特力材料 886-3-5753170
 勝特力电子(上海) 86-21-54151736
 勝特力电子(深圳) 86-755-83298787
[Http://www.100y.com.tw](http://www.100y.com.tw)

Technical Data Sheet

Specifications

Chemical System	Li / MnO ₂
Nominal Voltage	3 V
Rated Capacity	48 mAh
Standard Discharge Current	0,1 mA
Max. Cont. Discharge Current	1,0 mA
Average Weight	0,9 g
Temperature Range	-30 - +70 °C
Self Discharge at 23°C	< 1% / year

Dimensions

(According to IEC 60086)

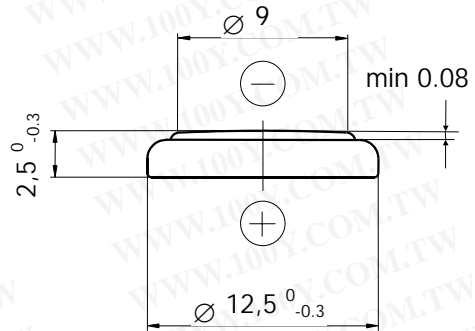

Performance

Discharge performance at 23°C

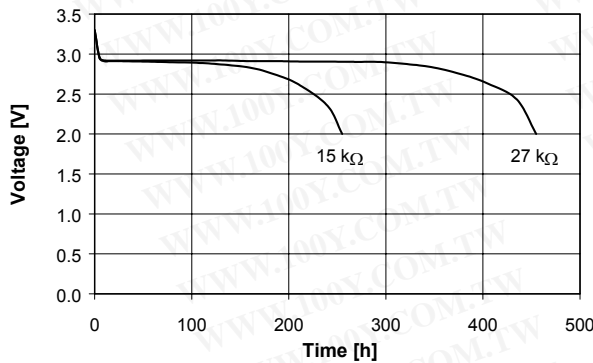

Discharge performance at 23°C

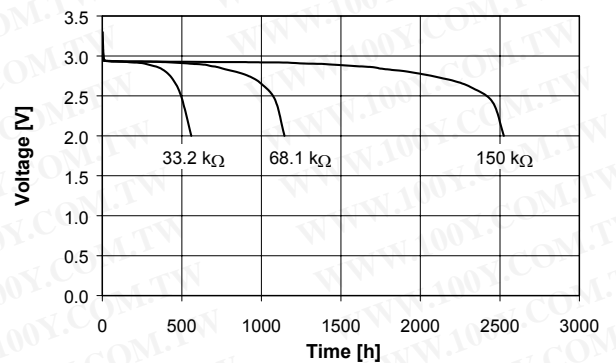

Temperature performance Load 27kΩ

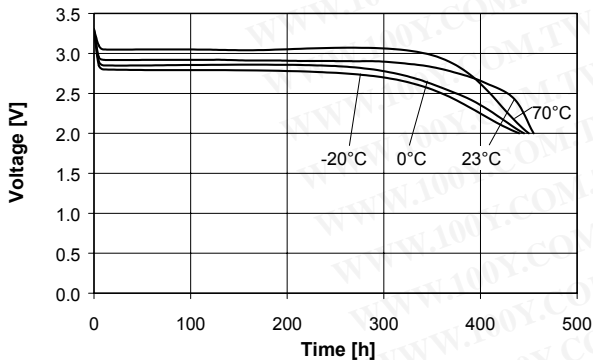

Cell capacity at various loads

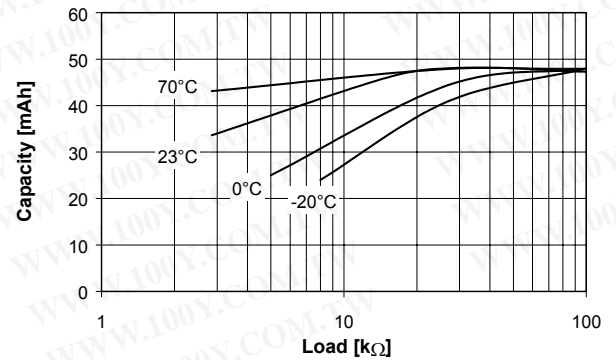

Rev. 1225.03 10/01