

CMOS Analog Multiplexers/Demultiplexers with Logic Level Conversion

The CD4051B, CD4052B, and CD4053B analog multiplexers are digitally-controlled analog switches having low ON impedance and very low OFF leakage current. Control of analog signals up to 20V_{P-P} can be achieved by digital signal amplitudes of 4.5V to 20V (if V_{DD}-V_{SS} = 3V, a V_{DD}-V_{EE} of up to 13V can be controlled; for V_{DD}-V_{EE} level differences above 13V, a V_{DD}-V_{SS} of at least 4.5V is required). For example, if V_{DD} = +4.5V, V_{SS} = 0V, and V_{EE} = -13.5V, analog signals from -13.5V to +4.5V can be controlled by digital inputs of 0V to 5V. These multiplexer circuits dissipate extremely low quiescent power over the full V_{DD}-V_{SS} and V_{DD}-V_{EE} supply-voltage ranges, independent of the logic state of the control signals. When a logic "1" is present at the inhibit input terminal, all channels are off.

The CD4051B is a single 8-Channel multiplexer having three binary control inputs, A, B, and C, and an inhibit input. The three binary signals select 1 of 8 channels to be turned on, and connect one of the 8 inputs to the output.

The CD4052B is a differential 4-Channel multiplexer having two binary control inputs, A and B, and an inhibit input. The two binary input signals select 1 of 4 pairs of channels to be turned on and connect the analog inputs to the outputs.

The CD4053B is a triple 2-Channel multiplexer having three separate digital control inputs, A, B, and C, and an inhibit input. Each control input selects one of a pair of channels which are connected in a single-pole, double-throw configuration.

When these devices are used as demultiplexers, the "CHANNEL IN/OUT" terminals are the outputs and the "COMMON OUT/IN" terminals are the inputs.

Ordering Information

PART NUMBER	TEMP. RANGE (°C)	PACKAGE
CD4051BF, CD4052BF, CD4053BF	-55 to 125	16 Ld CERAMIC DIP
CD4051BE, CD4052BE, CD4053BE	-55 to 125	16 Ld PDIP
CD4051BM, CD4051BNS	-55 to 125	16 Ld SOIC
CD4051BPW, CD4052BPW, CD4053BPW	-55 to 125	16 Ld TSSOP

Features

- Wide Range of Digital and Analog Signal Levels
 - Digital 3V to 20V
 - Analog ≤20V_{P-P}
- Low ON Resistance, 125Ω (Typ) Over 15V_{P-P} Signal Input Range for V_{DD}-V_{EE} = 18V
- High OFF Resistance, Channel Leakage of ±100pA (Typ) at V_{DD}-V_{EE} = 18V
- Logic-Level Conversion for Digital Addressing Signals of 3V to 20V (V_{DD}-V_{SS} = 3V to 20V) to Switch Analog Signals to 20V_{P-P} (V_{DD}-V_{EE} = 20V)
- Matched Switch Characteristics, r_{ON} = 5Ω (Typ) for V_{DD}-V_{EE} = 15V
- Very Low Quiescent Power Dissipation Under All Digital-Control Input and Supply Conditions, 0.2μW (Typ) at V_{DD}-V_{SS} = V_{DD}-V_{EE} = 10V
- Binary Address Decoding on Chip
- 5V, 10V and 15V Parametric Ratings
- 10% Tested for Quiescent Current at 20V
- Maximum Input Current of 1μA at 18V Over Full Package Temperature Range, 100nA at 18V and 25°C
- Break-Before-Make Switching Eliminates Channel Overlap

Applications

- Analog and Digital Multiplexing and Demultiplexing
- A/D and D/A Conversion
- Signal Gating

勝特力材料 886-3-5753170
 勝特力电子(上海) 86-21-54151736
 勝特力电子(深圳) 86-755-83298787
[Http://www.100y.com.tw](http://www.100y.com.tw)

CD4051B, CD4052B, CD4053B

勝特力材料 886-3-5753170
 勝特力电子(上海) 86-21-54151736
 勝特力电子(深圳) 86-755-83298787
[Http://www.100y.com.tw](http://www.100y.com.tw)

Pinouts

CD4051B (PDIP, CDIP, SOIC, TSSOP)
TOP VIEW

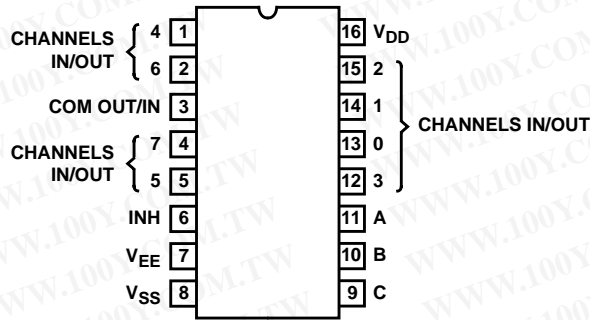

CD4052B (PDIP, CDIP, TSSOP)
TOP VIEW

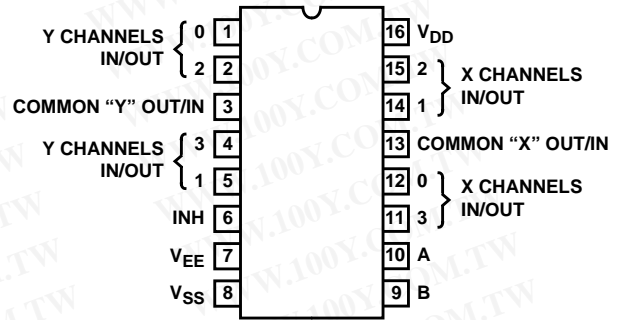

CD4053B (PDIP, CDIP, TSSOP)
TOP VIEW

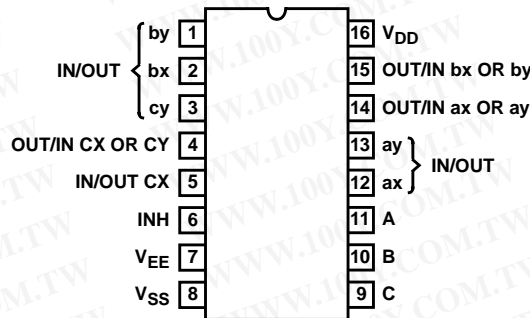

Functional Block Diagrams

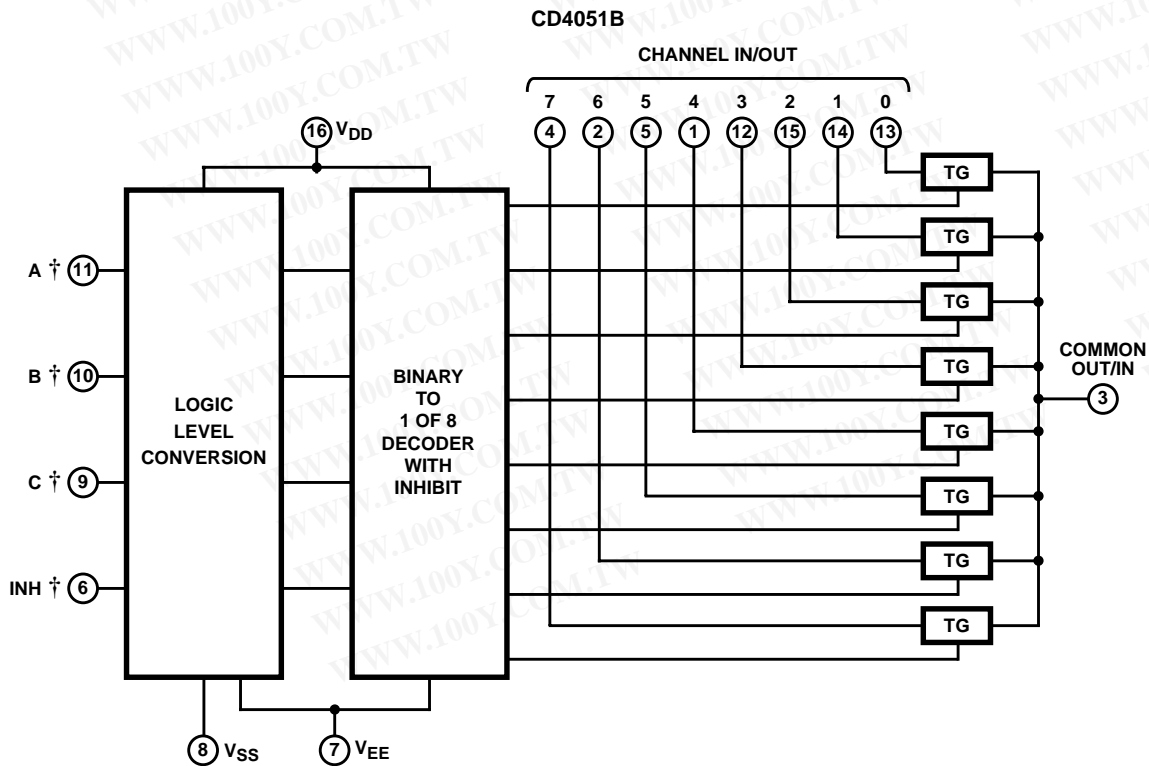

† All inputs are protected by standard CMOS protection network.

勝特力材料 886-3-5753170
 勝特力电子(上海) 86-21-54151736
 勝特力电子(深圳) 86-755-83298787
[Http://www.100y.com.tw](http://www.100y.com.tw)

Functional Block Diagrams (Continued)

CD4052B

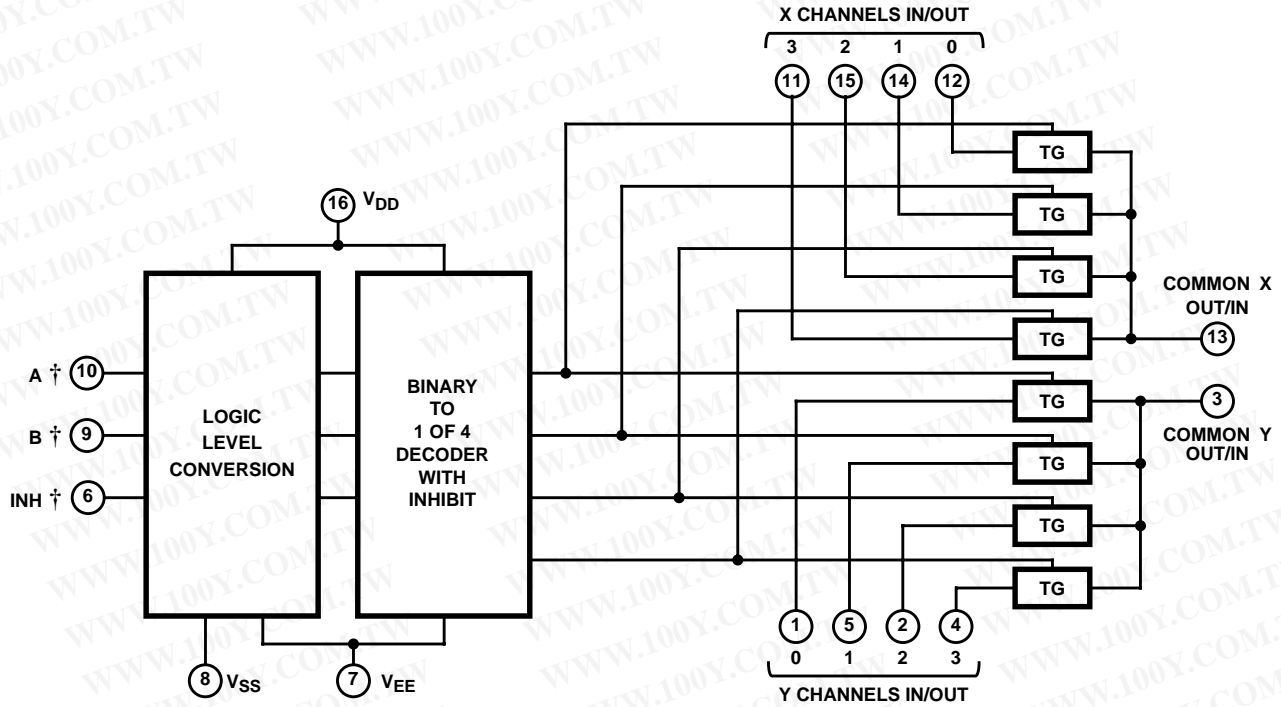

CD4053B

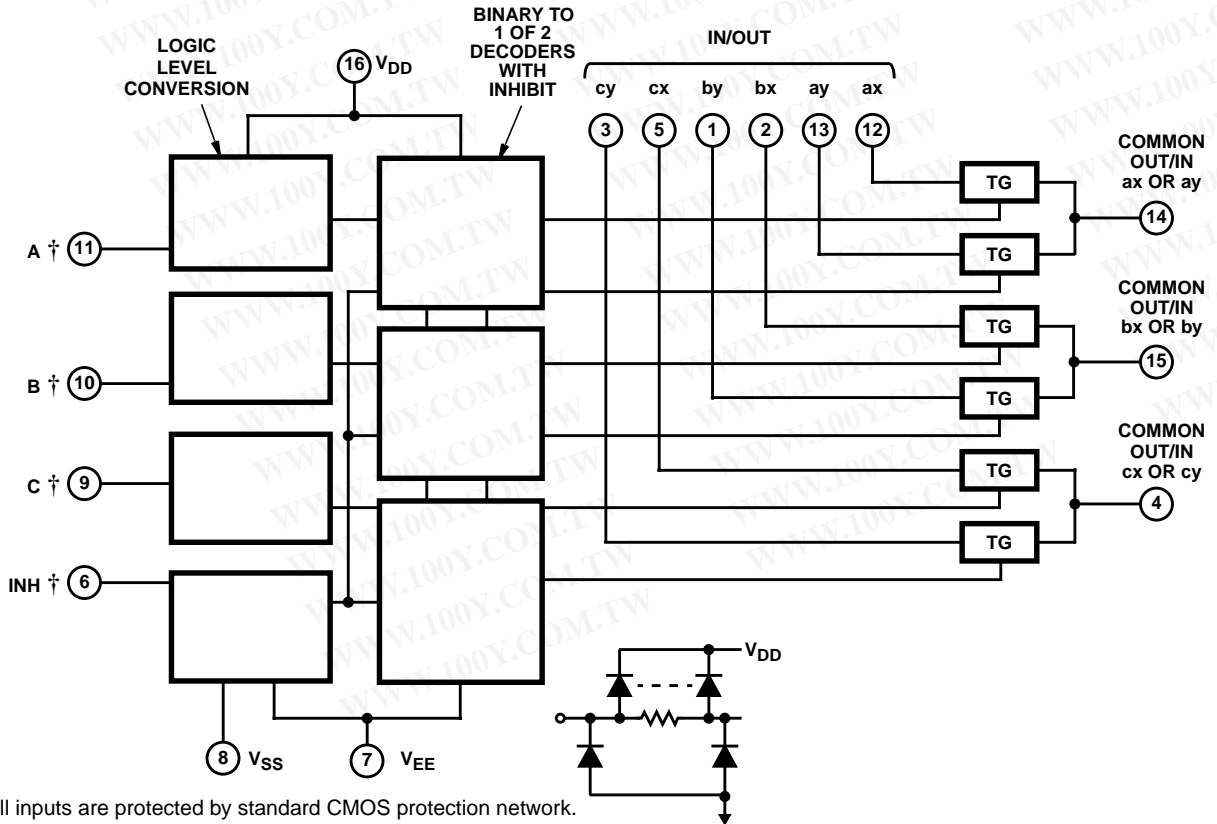

† All inputs are protected by standard CMOS protection network.

CD4051B, CD4052B, CD4053B

勝特力材料 886-3-5753170
 勝特力电子(上海) 86-21-54151736
 勝特力电子(深圳) 86-755-83298787
[Http://www.100y.com.tw](http://www.100y.com.tw)

TRUTH TABLES

INPUT STATES				"ON" CHANNEL(S)
INHIBIT	C	B	A	
CD4051B				
0	0	0	0	0
0	0	0	1	1
0	0	1	0	2
0	0	1	1	3
0	1	0	0	4
0	1	0	1	5
0	1	1	0	6
0	1	1	1	7
1	X	X	X	None
CD4052B				
INHIBIT	B	A		
0	0	0	0x, 0y	
0	0	1	1x, 1y	
0	1	0	2x, 2y	
0	1	1	3x, 3y	
1	X	X	None	
CD4053B				
INHIBIT	A OR B OR C			
0	0		ax or bx or cx	
0	1		ay or by or cy	
1	X		None	

X = Don't Care

CD4051B, CD4052B, CD4053B

勝特力材料 886-3-5753170
勝特力电子(上海) 86-21-54151736
勝特力电子(深圳) 86-755-83298787
[Http://www.100y.com.tw](http://www.100y.com.tw)

Absolute Maximum Ratings

Supply Voltage (V+ to V-)	
Voltages Referenced to V _{SS} Terminal	-0.5V to 20V
DC Input Voltage Range	-0.5V to V _{DD} +0.5V
DC Input Current, Any One Input	±10mA

Operating Conditions

Temperature Range	-55°C to 125°C
-------------------	----------------

Thermal Information

Thermal Resistance (Typical, Note 1)	θ_{JA} (°C/W)	θ_{JC} (°C/W)
E Package	67	N/A
F Package	115	45
D Package	73	N/A
NS Package	64	N/A
PW Package	108	N/A
Maximum Junction Temperature (Ceramic Package)	175°C	
Maximum Junction Temperature (Plastic Package)	150°C	
Maximum Storage Temperature Range	-65°C to 150°C	
Maximum Lead Temperature (Soldering 10s)	265°C	
(SOIC - Lead Tips Only)		

CAUTION: Stresses above those listed in "Absolute Maximum Ratings" may cause permanent damage to the device. This is a stress only rating and operation of the device at these or any other conditions above those indicated in the operational sections of this specification is not implied.

NOTE:

- The package thermal impedance is calculated in accordance with JESD51.

Electrical Specifications

Common Conditions Here: If Whole Table is For the Full Temp. Range, V_{SUPPLY} = ±5V, A_V = +1, R_L = 100Ω, Unless Otherwise Specified (Note 3)

PARAMETER	CONDITIONS				LIMITS AT INDICATED TEMPERATURES (°C)							UNITS
	V _{IS} (V)	V _{EE} (V)	V _{SS} (V)	V _{DD} (V)	-55	-40	85	125	25			
									MIN	TYP	MAX	
SIGNAL INPUTS (V_{IS}) AND OUTPUTS (V_{OS})												
Quiescent Device Current, I _{DD} Max	-	-	-	5	5	5	150	150	-	0.04	5	μA
	-	-	-	10	10	10	300	300	-	0.04	10	μA
	-	-	-	15	20	20	600	600	-	0.04	20	μA
	-	-	-	20	100	100	3000	3000	-	0.08	100	μA
Drain to Source ON Resistance r _{ON} Max 0 ≤ V _{IS} ≤ V _{DD}	-	0	0	5	800	850	1200	1300	-	470	1050	Ω
	-	0	0	10	310	330	520	550	-	180	400	Ω
	-	0	0	15	200	210	300	320	-	125	240	Ω
Change in ON Resistance (Between Any Two Channels), Δr _{ON}	-	0	0	5	-	-	-	-	-	15	-	Ω
	-	0	0	10	-	-	-	-	-	10	-	Ω
	-	0	0	15	-	-	-	-	-	5	-	Ω
OFF Channel Leakage Current: Any Channel OFF (Max) or ALL Channels OFF (Common OUT/IN) (Max)	-	0	0	18	±100 (Note 2)		±1000 (Note 2)		-	±0.01	±100 (Note 2)	nA
Capacitance:	-	-5	5-	5								
Input, C _{IS}					-	-	-	-	-	5	-	pF
Output, C _{OS}												
CD4051					-	-	-	-	-	30	-	pF
CD4052					-	-	-	-	-	18	-	pF
CD4053					-	-	-	-	-	9	-	pF
Feedthrough C _{IOS}					-	-	-	-	-	0.2	-	pF
Propagation Delay Time (Signal Input to Output)		V _{DD}	R _L = 200kΩ, C _L = 50pF, t _r , t _f = 20ns	5	-	-	-	-	-	30	60	ns
				10	-	-	-	-	-	15	30	ns
				15	-	-	-	-	-	10	20	ns

CD4051B, CD4052B, CD4053B

Electrical Specifications Common Conditions Here: If Whole Table is For the Full Temp. Range, $V_{SUPPLY} = \pm 5V$, $A_V = +1$, $R_L = 100\Omega$, Unless Otherwise Specified **(Continued)** (Note 3)

PARAMETER	CONDITIONS				LIMITS AT INDICATED TEMPERATURES (°C)							UNITS
	V_{IS} (V)	V_{EE} (V)	V_{SS} (V)	V_{DD} (V)	-55	-40	85	125	25			
									MIN	TYP	MAX	
CONTROL (ADDRESS OR INHIBIT), V_C												
Input Low Voltage, V_{IL} , Max	$V_{IL} = V_{DD}$ through 1k Ω ; $V_{IH} = V_{DD}$ through 1k Ω	$V_{EE} = V_{SS}$, $R_L = 1k\Omega$ to V_{SS} , $I_{IS} < 2\mu A$ on All OFF Channels	5	1.5	1.5	1.5	1.5	-	-	1.5	V	
			10	3	3	3	3	-	-	3	V	
			15	4	4	4	4	-	-	4	V	
Input High Voltage, V_{IH} , Min	$V_{IL} = V_{DD}$ through 1k Ω ; $V_{IH} = V_{DD}$ through 1k Ω	$V_{EE} = V_{SS}$, $R_L = 1k\Omega$ to V_{SS} , $I_{IS} < 2\mu A$ on All OFF Channels	5	3.5	3.5	3.5	3.5	3.5	-	-	V	
			10	7	7	7	7	7	-	-	V	
			15	11	11	11	11	11	-	-	V	
Input Current, I_{IN} (Max)	$V_{IN} = 0, 18$		18	± 0.1	± 0.1	± 1	± 1	-	$\pm 10^{-5}$	± 0.1	μA	
Propagation Delay Time: Address-to-Signal OUT (Channels ON or OFF) See Figures 10, 11, 14	$t_r, t_f = 20ns$, $C_L = 50pF$, $R_L = 10k\Omega$	0	0	5	-	-	-	-	-	450	720	ns
		0	0	10	-	-	-	-	-	160	320	ns
		0	0	15	-	-	-	-	-	120	240	ns
		-5	0	5	-	-	-	-	-	225	450	ns
Propagation Delay Time: Inhibit-to-Signal OUT (Channel Turning ON) See Figure 11	$t_r, t_f = 20ns$, $C_L = 50pF$, $R_L = 1k\Omega$	0	0	5	-	-	-	-	-	400	720	ns
		0	0	10	-	-	-	-	-	160	320	ns
		0	0	15	-	-	-	-	-	120	240	ns
		-10	0	5	-	-	-	-	-	200	400	ns
Propagation Delay Time: Inhibit-to-Signal OUT (Channel Turning OFF) See Figure 15	$t_r, t_f = 20ns$, $C_L = 50pF$, $R_L = 10k\Omega$	0	0	5	-	-	-	-	-	200	450	ns
		0	0	10	-	-	-	-	-	90	210	ns
		0	0	15	-	-	-	-	-	70	160	ns
		-10	0	5	-	-	-	-	-	130	300	ns
Input Capacitance, C_{IN} (Any Address or Inhibit Input)				-	-	-	-	-	5	7.5	pF	

NOTE:

- Determined by minimum feasible leakage measurement for automatic testing.

Electrical Specifications

PARAMETER	TEST CONDITIONS			LIMITS		UNITS	
	V_{IS} (V)	V_{DD} (V)	R_L (k Ω)	TYP			
Cutoff (-3dB) Frequency Channel ON (Sine Wave Input)	5 (Note 3)	10	1	V_{OS} at Common OUT/IN	CD4053	30	MHz
					CD4052	25	MHz
	CD4051	20	MHz				
	$V_{EE} = V_{SS}$, $20 \log \frac{V_{OS}}{V_{IS}} = -3dB$				V_{OS} at Any Channel	60	MHz

勝特力材料 886-3-5753170
 勝特力电子(上海) 86-21-54151736
 勝特力电子(深圳) 86-755-83298787
[Http://www.100y.com.tw](http://www.100y.com.tw)

Electrical Specifications

PARAMETER	TEST CONDITIONS			LIMITS			
	V _{IS} (V)	V _{DD} (V)	R _L (kΩ)	TYP	UNITS		
Total Harmonic Distortion, THD	2 (Note 3)	5	10		0.3	%	
	3 (Note 3)	10			0.2	%	
	5 (Note 3)	15			0.12	%	
	V _{EE} = V _{SS} , f _{IS} = 1kHz Sine Wave					%	
-40dB Feedthrough Frequency (All Channels OFF)	5 (Note 3)	10	1	V _{OS} at Common OUT/IN	CD4053	8	MHz
					CD4052	10	MHz
				CD4051	12	MHz	
	V _{EE} = V _{SS} , 20Log $\frac{V_{OS}}{V_{IS}} = -40\text{dB}$				V _{OS} at Any Channel	8	MHz
-40dB Signal Crosstalk Frequency	5 (Note 3)	10	1	Between Any 2 Channels		3	MHz
				Between Sections, CD4052 Only	Measured on Common	6	MHz
					Measured on Any Channel	10	MHz
				Between Any Two Sections, CD4053 Only	In Pin 2, Out Pin 14	2.5	MHz
					In Pin 15, Out Pin 14	6	MHz
Address-or-Inhibit-to-Signal Crosstalk	-	10	10 (Note 4)		65	mV _{PEAK}	
	V _{EE} = 0, V _{SS} = 0, t _r , t _f = 20ns, V _{CC} = V _{DD} - V _{SS} (Square Wave)				65	mV _{PEAK}	

NOTES:

- Peak-to-Peak voltage symmetrical about $\frac{V_{DD} - V_{EE}}{2}$
- Both ends of channel.

Typical Performance Curves

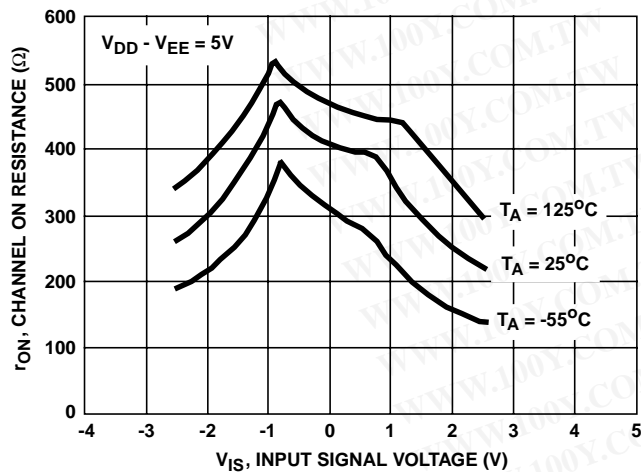

FIGURE 1. CHANNEL ON RESISTANCE vs INPUT SIGNAL VOLTAGE (ALL TYPES)

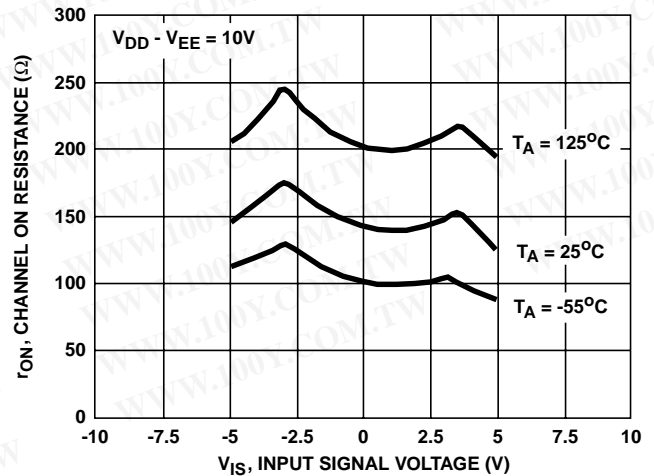

FIGURE 2. CHANNEL ON RESISTANCE vs INPUT SIGNAL VOLTAGE (ALL TYPES)

Typical Performance Curves (Continued)

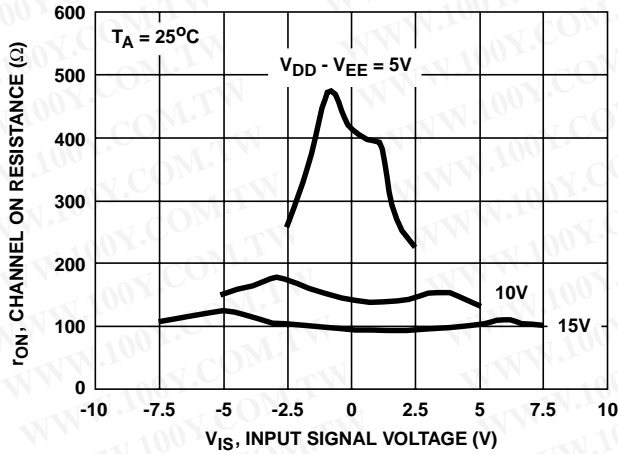

FIGURE 3. CHANNEL ON RESISTANCE vs INPUT SIGNAL VOLTAGE (ALL TYPES)

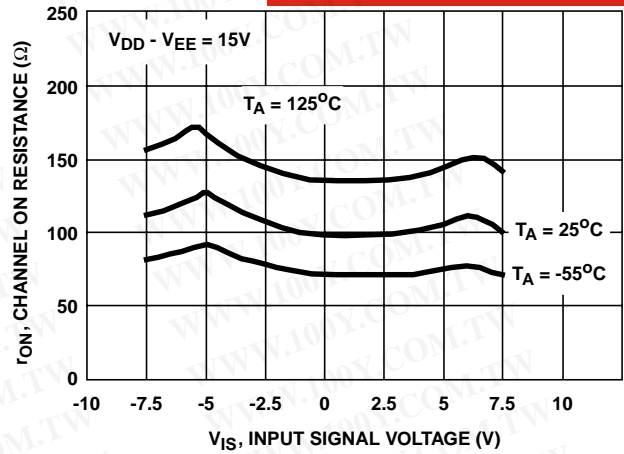

FIGURE 4. CHANNEL ON RESISTANCE vs INPUT SIGNAL VOLTAGE (ALL TYPES)

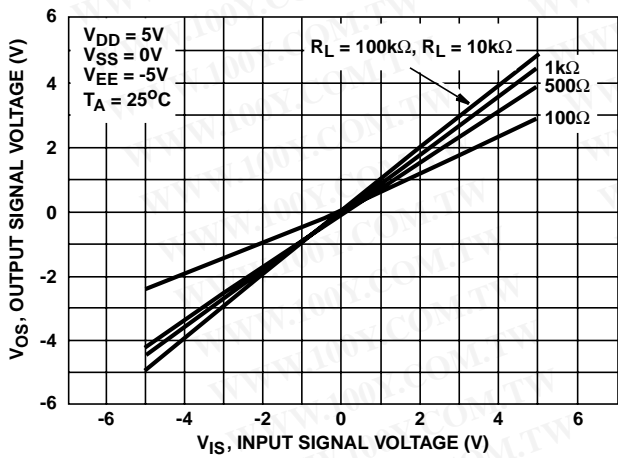

FIGURE 5. ON CHARACTERISTICS FOR 1 OF 8 CHANNELS (CD4051B)

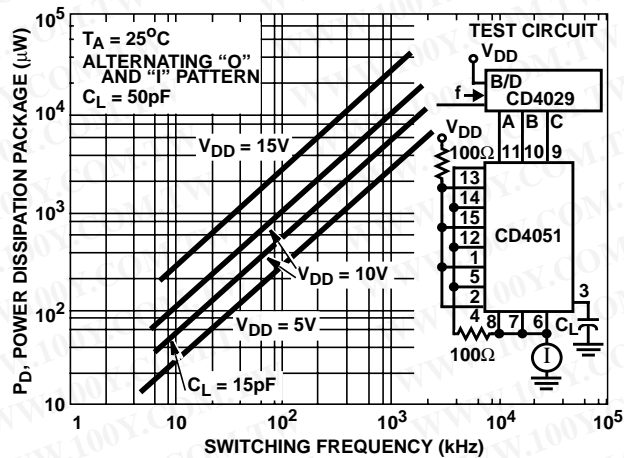

FIGURE 6. DYNAMIC POWER DISSIPATION vs SWITCHING FREQUENCY (CD4051B)

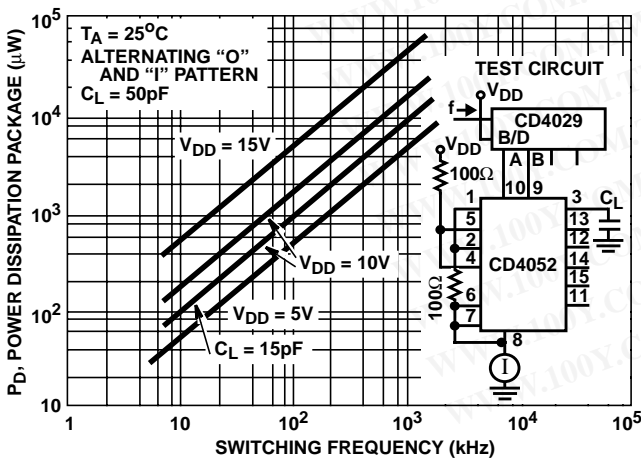

FIGURE 7. DYNAMIC POWER DISSIPATION vs SWITCHING FREQUENCY (CD4052B)

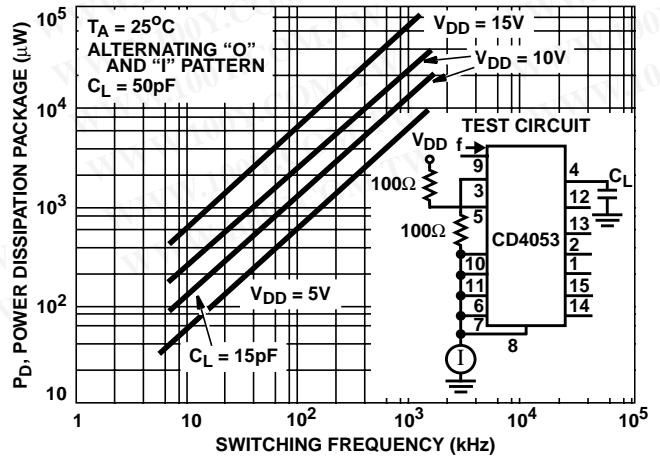
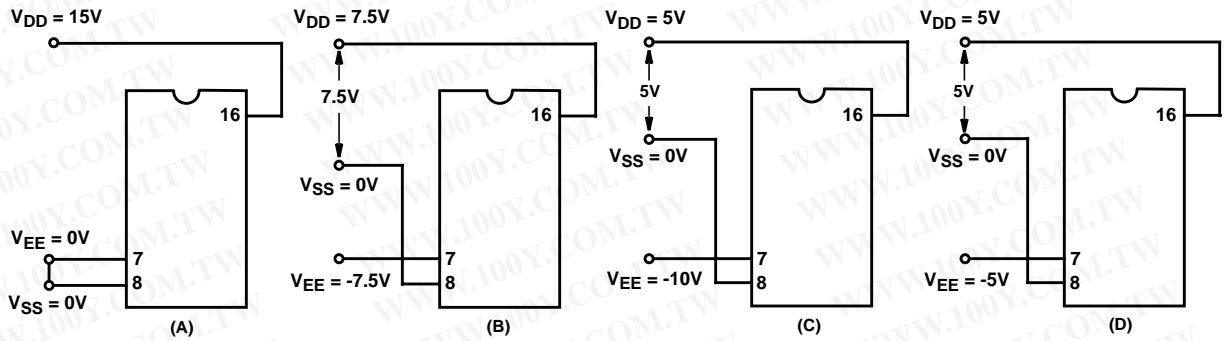

FIGURE 8. DYNAMIC POWER DISSIPATION vs SWITCHING FREQUENCY (CD4053B)

Test Circuits and Waveforms



NOTE: The ADDRESS (digital-control inputs) and INHIBIT logic levels are: "0" = V_{SS} and "1" = V_{DD} . The analog signal (through the TG) may swing from V_{EE} to V_{DD} .

FIGURE 9. TYPICAL BIAS VOLTAGES

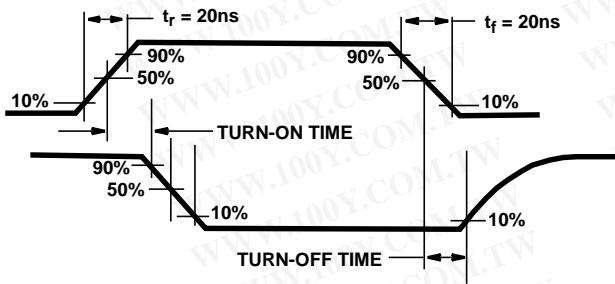

FIGURE 10. WAVEFORMS, CHANNEL BEING TURNED ON ($R_L = 1k\Omega$)

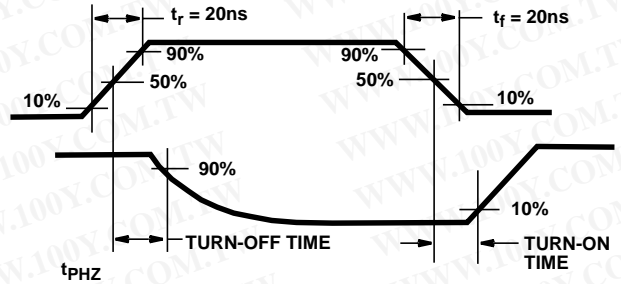

FIGURE 11. WAVEFORMS, CHANNEL BEING TURNED OFF ($R_L = 1k\Omega$)

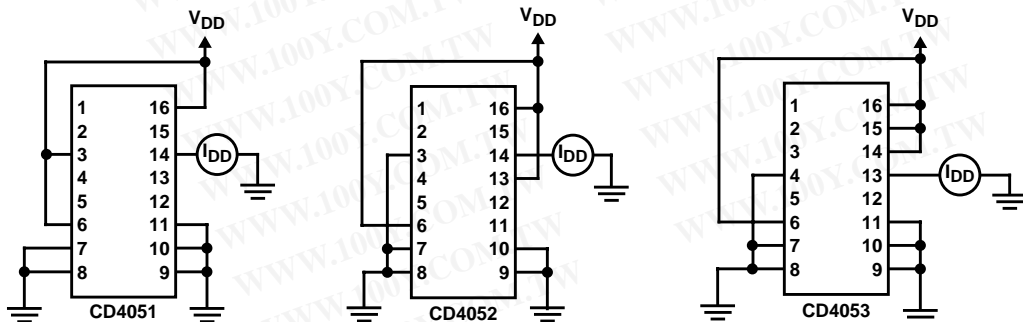

FIGURE 12. OFF CHANNEL LEAKAGE CURRENT - ANY CHANNEL OFF

Test Circuits and Waveforms (Continued)

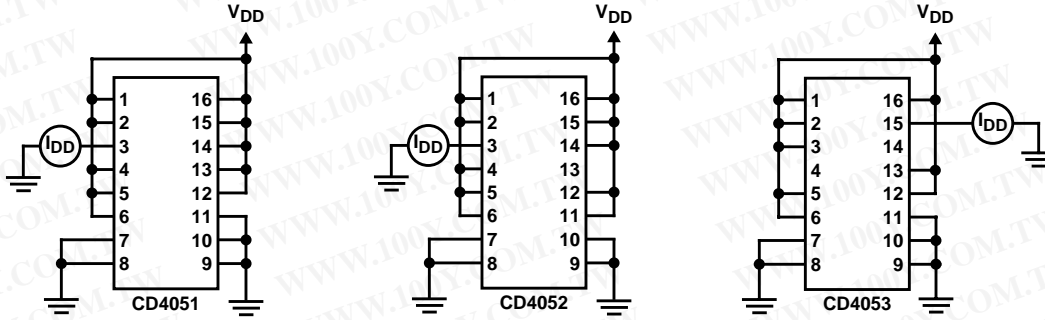

FIGURE 13. OFF CHANNEL LEAKAGE CURRENT - ALL CHANNELS OFF

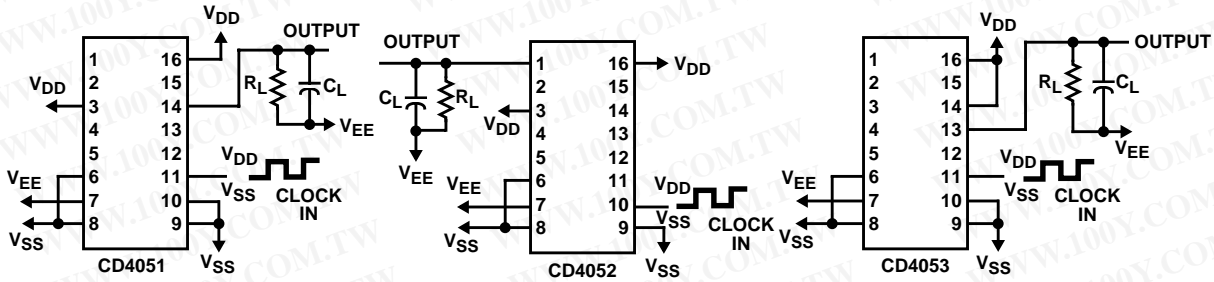

FIGURE 14. PROPAGATION DELAY - ADDRESS INPUT TO SIGNAL OUTPUT

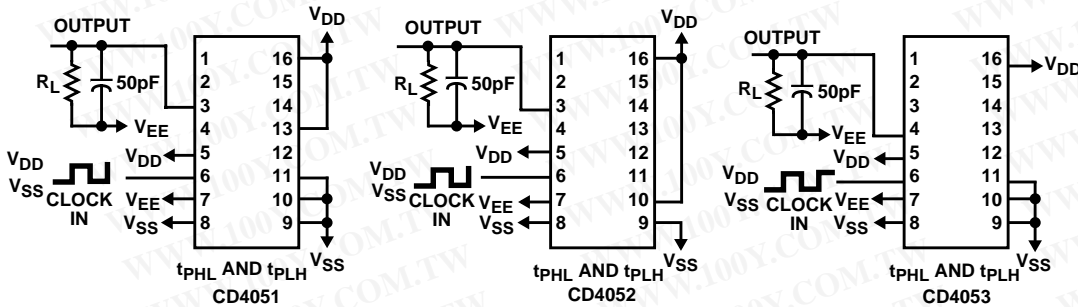
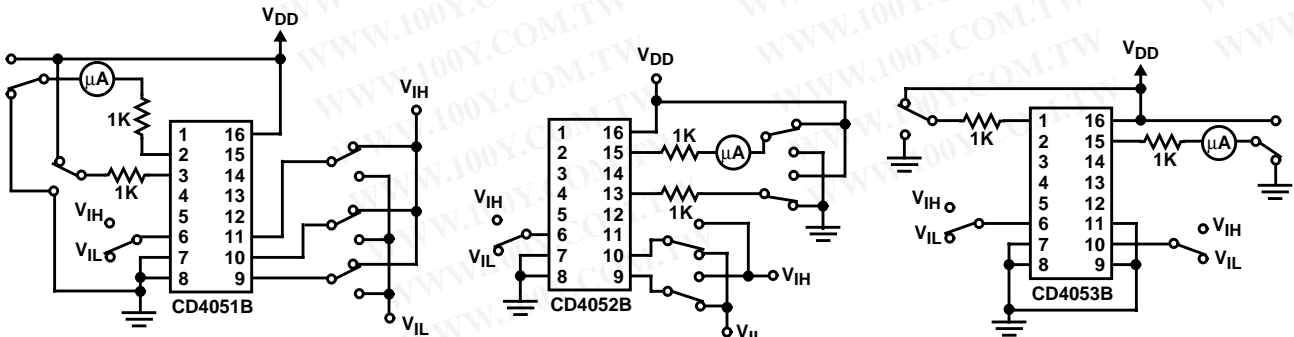

FIGURE 15. PROPAGATION DELAY - INHIBIT INPUT TO SIGNAL OUTPUT



MEASURE $2\mu\text{A}$ ON ALL "OFF" CHANNELS (e.g., CHANNEL 6)

MEASURE $2\mu\text{A}$ ON ALL "OFF" CHANNELS (e.g., CHANNEL 2x)

MEASURE $2\mu\text{A}$ ON ALL "OFF" CHANNELS (e.g., CHANNEL by)

FIGURE 16. INPUT VOLTAGE TEST CIRCUITS (NOISE IMMUNITY)

Test Circuits and Waveforms (Continued)

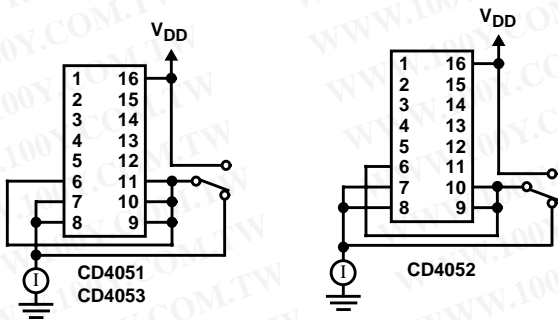

FIGURE 17. QUIESCENT DEVICE CURRENT

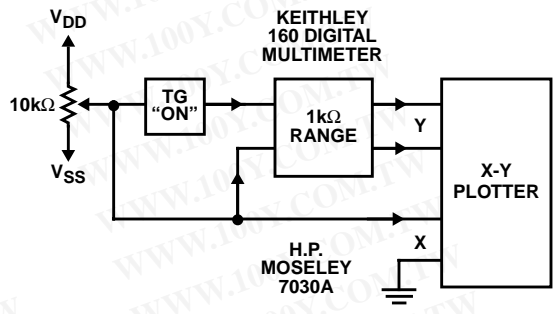

FIGURE 18. CHANNEL ON RESISTANCE MEASUREMENT CIRCUIT

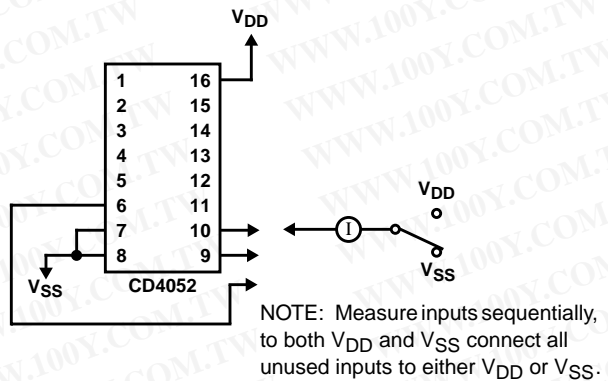
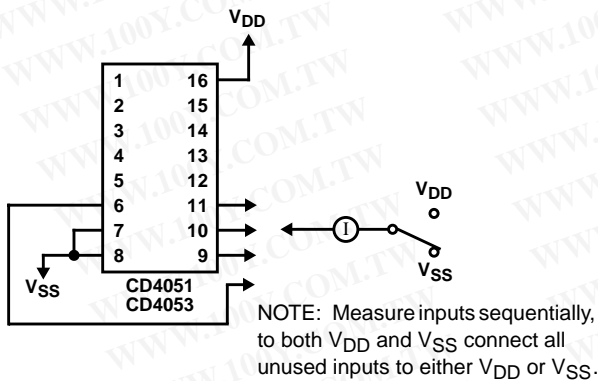

FIGURE 19. INPUT CURRENT

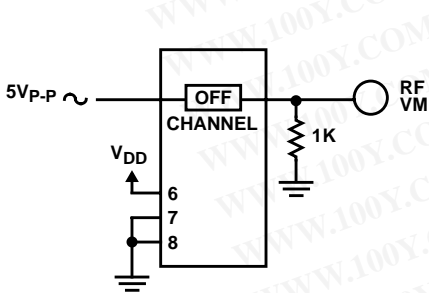

FIGURE 20. FEEDTHROUGH (ALL TYPES)

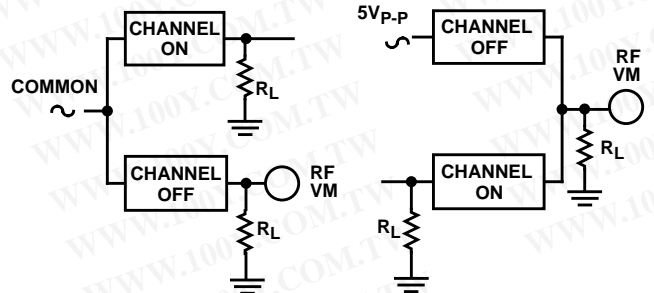

FIGURE 21. CROSSTALK BETWEEN ANY TWO CHANNELS (ALL TYPES)

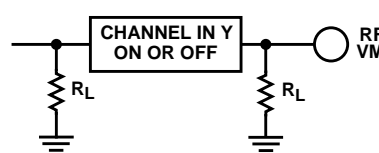
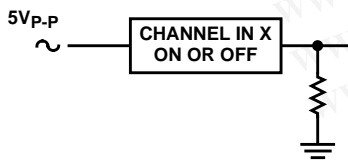

FIGURE 22. CROSSTALK BETWEEN DUALS OR TRIPLETS (CD4052B, CD4053B)

Test Circuits and Waveforms (Continued)

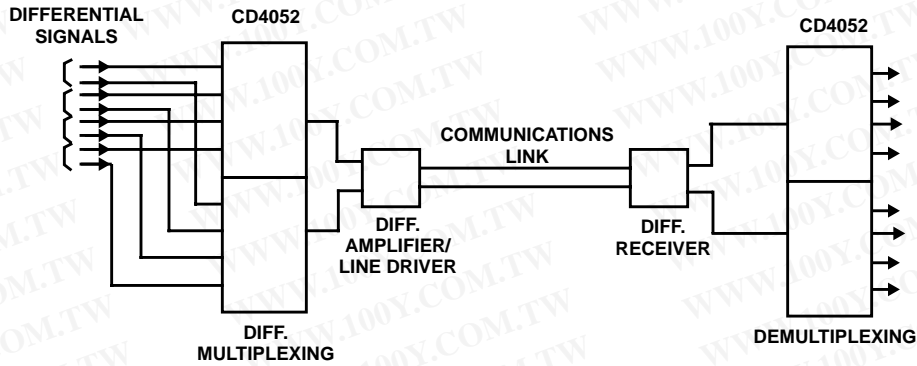

FIGURE 23. TYPICAL TIME-DIVISION APPLICATION OF THE CD4052B

Special Considerations

In applications where separate power sources are used to drive V_{DD} and the signal inputs, the V_{DD} current capability should exceed V_{DD}/R_L (R_L = effective external load). This provision avoids permanent current flow or clamp action on the V_{DD} supply when power is applied or removed from the CD4051B, CD4052B or CD4053B.

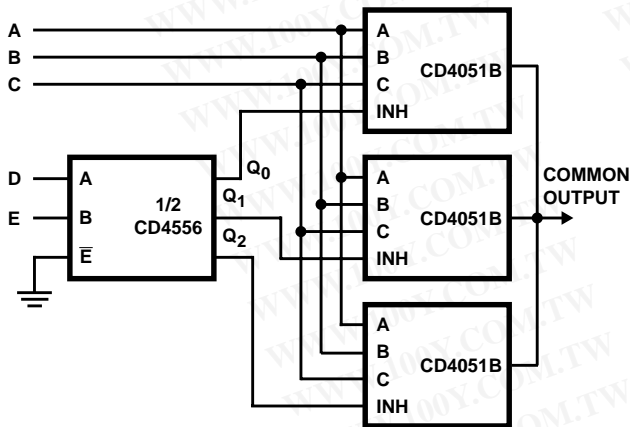

FIGURE 24. 24-TO-1 MUX ADDRESSING

勝特力材料 886-3-5753170
 勝特力电子(上海) 86-21-54151736
 勝特力电子(深圳) 86-755-83298787
[Http://www.100y.com.tw](http://www.100y.com.tw)

勝特力材料 886-3-5753170
勝特力电子(上海) 86-21-54151736
勝特力电子(深圳) 86-755-83298787
[Http://www.100y.com.tw](http://www.100y.com.tw)

IMPORTANT NOTICE

Texas Instruments and its subsidiaries (TI) reserve the right to make changes to their products or to discontinue any product or service without notice, and advise customers to obtain the latest version of relevant information to verify, before placing orders, that information being relied on is current and complete. All products are sold subject to the terms and conditions of sale supplied at the time of order acknowledgment, including those pertaining to warranty, patent infringement, and limitation of liability.

TI warrants performance of its semiconductor products to the specifications applicable at the time of sale in accordance with TI's standard warranty. Testing and other quality control techniques are utilized to the extent TI deems necessary to support this warranty. Specific testing of all parameters of each device is not necessarily performed, except those mandated by government requirements.

Customers are responsible for their applications using TI components.

In order to minimize risks associated with the customer's applications, adequate design and operating safeguards must be provided by the customer to minimize inherent or procedural hazards.

TI assumes no liability for applications assistance or customer product design. TI does not warrant or represent that any license, either express or implied, is granted under any patent right, copyright, mask work right, or other intellectual property right of TI covering or relating to any combination, machine, or process in which such semiconductor products or services might be or are used. TI's publication of information regarding any third party's products or services does not constitute TI's approval, warranty or endorsement thereof.

Copyright © 2000, Texas Instruments Incorporated