



October 1987
Revised April 2002

CD4024BC 7-Stage Ripple Carry Binary Counter

General Description

The CD4024BC is a 7-stage ripple-carry binary counter. Buffered outputs are externally available from stages 1 through 7. The counter is reset to its logical "0" stage by a logical "1" on the reset input. The counter is advanced one count on the negative transition of each clock pulse.

Features

- Wide supply voltage range: 3.0V to 15V
- High noise immunity: 0.45 V_{DD} (typ.)
- Low power TTL compatibility: Fan out of 2 driving 74L or 1 driving 74LS
- High speed: 12 MHz (typ.)
input pulse rate $V_{DD} - V_{SS} = 10V$
- Fully static operation

Ordering Code:

Order Number	Package Number	Package Description
CD4024BCM	M14A	14-Lead Small Outline Integrated Circuit (SOIC), JEDEC MS-012, 0.150" Narrow
CD4024BCN	N14A	14-Lead Plastic Dual-In-Line Package (PDIP), JEDEC MS-001, 0.300" Wide

Devices also available in Tape and Reel. Specify by appending the suffix letter "X" to the ordering code.

Connection Diagram

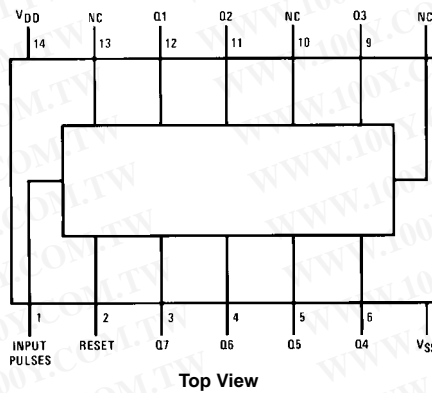

CD4024BC 7-Stage Ripple Carry Binary Counter

CD4024BC

Logic Diagrams

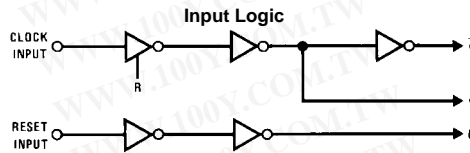
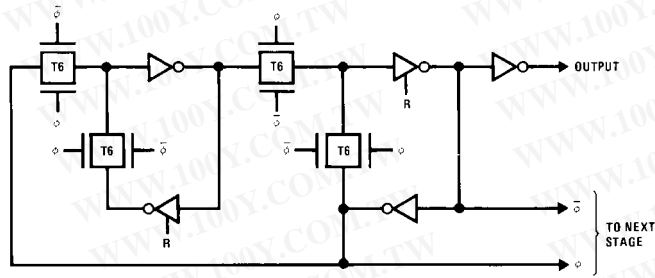

Flip-flop logic (1 of 7 identical stages).

Block Diagram

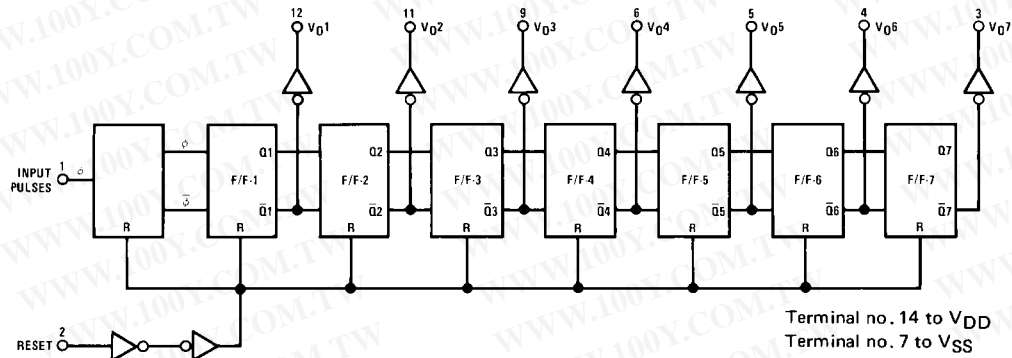

Absolute Maximum Ratings (Note 1)

(Note 2)

DC Supply Voltage (V_{DD})	-0.5 to +18 V_{DC}
Input Voltage (V_{IN})	-0.5 to V_{DD} + 0.5 V_{DC}
Storage Temperature Range (T_S)	-65°C to +150°C
Power Dissipation (P_D)	
Dual-In-Line	700 mW
Small Outline	500 mW
Lead Temperature	
(Soldering, 10 seconds) (T_L)	260°C

Recommended Operating Conditions (Note 1)

DC Supply Voltage (V_{DD})	+3 to +15 V_{DC}
Input Voltage (V_{IN})	0 to V_{DD} V_{DC}
Operating Temperature Range (T_A)	-55°C to +125°C

Note 1: "Absolute Maximum Ratings" are those values beyond which the safety of the device cannot be guaranteed, they are not meant to imply that the devices should be operated at these limits. The table of "Recommended Operating Conditions" and "Electrical Characteristics" provides conditions for actual device operation.

Note 2: $V_{SS} = 0V$ unless otherwise specified.

DC Electrical Characteristics (Note 2)

Symbol	Parameter	Conditions	-55°C		+25°C			+125°C		Units
			Min	Max	Min	Typ	Max	Min	Max	
I_{DD}	Quiescent Device Current	$V_{DD} = 5V$ $V_{DD} = 10V$ $V_{DD} = 15V$		5 10 20		0.3 0.5 0.7	5 10 20		150 300 600	μA
V_{OL}	LOW Level Output Voltage	$ I_O < 1 \mu A$ $V_{DD} = 5V$ $V_{DD} = 10V$ $V_{DD} = 15V$		0.05 0.05 0.05		0 0 0	0.05 0.05 0.05		0.05 0.05 0.05	V
V_{OH}	HIGH Level Output Voltage	$ I_O < 1 \mu A$ $V_{DD} = 5V$ $V_{DD} = 10V$ $V_{DD} = 15V$	4.95 9.95 14.95		4.95 9.95 14.95	5 10 15		4.95 9.95 14.95		V
V_{IL}	LOW Level Input Voltage	$ I_O < 1 \mu A$ $V_{DD} = 5V, V_O = 0.5V$ or 4.5V $V_{DD} = 10V, V_O = 1.0V$ or 9.0V $V_{DD} = 15V, V_O = 1.5V$ or 13.5V		1.5 3.0 4.0		2 4 6	1.5 3.0 4.0		1.5 3.0 4.0	V
V_{IH}	HIGH Level Input Voltage	$ I_O < 1 \mu A$ $V_{DD} = 5V, V_O = 0.5V$ or 4.5V $V_{DD} = 10V, V_O = 1.0V$ or 9.0V $V_{DD} = 15V, V_O = 1.5V$ or 13.5V	3.5 7.0 11.0		3.5 7.0 11.0	3 6 9		3.5 7.0 11.0		V
I_{OL}	LOW Level Output Current (Note 3)	$V_{DD} = 5V, V_O = 0.4V$ $V_{DD} = 10V, V_O = 0.5V$ $V_{DD} = 15V, V_O = 1.5V$	0.64 1.6 4.2		0.51 1.3 3.4	0.88 2.25 8.8		0.36 0.9 2.4		mA
I_{OH}	HIGH Level Output Current (Note 3)	$V_{DD} = 5V, V_O = 4.6V$ $V_{DD} = 10V, V_O = 9.5V$ $V_{DD} = 15V, V_O = 13.5V$	-0.64 -1.6 -4.2		-0.51 -1.3 -3.4	-0.88 -2.25 -8.8		-0.36 -0.9 -2.4		mA
I_{IN}	Input Current	$V_{DD} = 15V, V_{IN} = 0V$ $V_{DD} = 15V, V_{IN} = 15V$		-0.1 0.1		-10^{-5} 10^{-5}	-0.1 0.1		-1.0 1.0	μA

Note 3: I_{OH} and I_{OL} are tested one output at a time.

CD4024BC

AC Electrical Characteristics (Note 4)

$T_A = 25^\circ\text{C}$, $C_L = 50\text{ pF}$, $R_L = 200\text{ k}$, t_r and $t_f = 20\text{ ns}$ unless otherwise specified

Symbol	Parameter	Conditions	Min	Typ	Max	Units
t_{PHL} , t_{PLH}	Propagation Delay Time to Q1 Output	$V_{DD} = 5V$ $V_{DD} = 10V$ $V_{DD} = 15V$		185 85 70	350 125 100	ns
t_{THL} , t_{TLH}	Transition Time	$V_{DD} = 5V$ $V_{DD} = 10V$ $V_{DD} = 15V$		100 50 40	200 100 80	ns
t_{WL} , t_{WH}	Minimum Input Pulse Width	$V_{DD} = 5V$ $V_{DD} = 10V$ $V_{DD} = 15V$		75 40 35	200 110 90	ns
t_{RCL} , t_{FCL}	Input Rise and Fall Time	$V_{DD} = 5V$ $V_{DD} = 10V$ $V_{DD} = 15V$			15 10 8	μs
f_{CL}	Maximum Input Pulse Frequency	$V_{DD} = 5V$ $V_{DD} = 10V$ $V_{DD} = 15V$	1.5 4 5	5 12 15		MHz
t_{PHL}	Reset Propagation Delay Time	$V_{DD} = 5V$ $V_{DD} = 10V$ $V_{DD} = 15V$		185 85 70	350 125 100	ns
t_{WH}	Reset Minimum Pulse Width	$V_{DD} = 5V$ $V_{DD} = 10V$ $V_{DD} = 15V$		185 85 70	350 125 100	ns
C_{IN}	Input Capacitance (Note 5)	Any Input		5	7.5	pF

Note 4: AC Parameters are guaranteed by DC correlated testing.

Note 5: Capacitance is guaranteed by periodic testing.

CD4024BC

Physical Dimensions inches (millimeters) unless otherwise noted

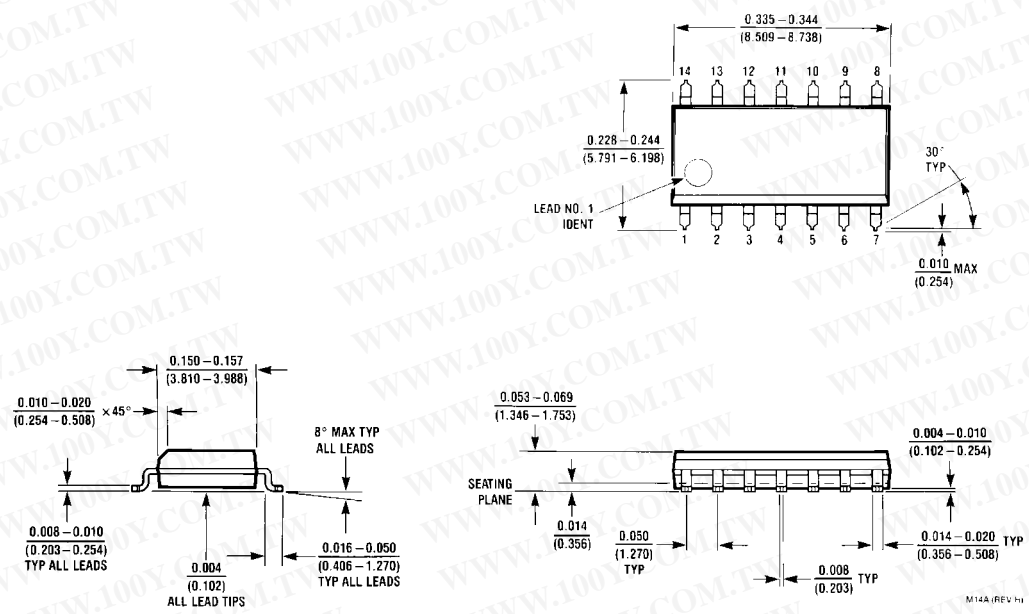

14-Lead Small Outline Integrated Circuit (SOIC), JEDEC MS-012, 0.150" Narrow Package Number M14A

Physical Dimensions inches (millimeters) unless otherwise noted (Continued)

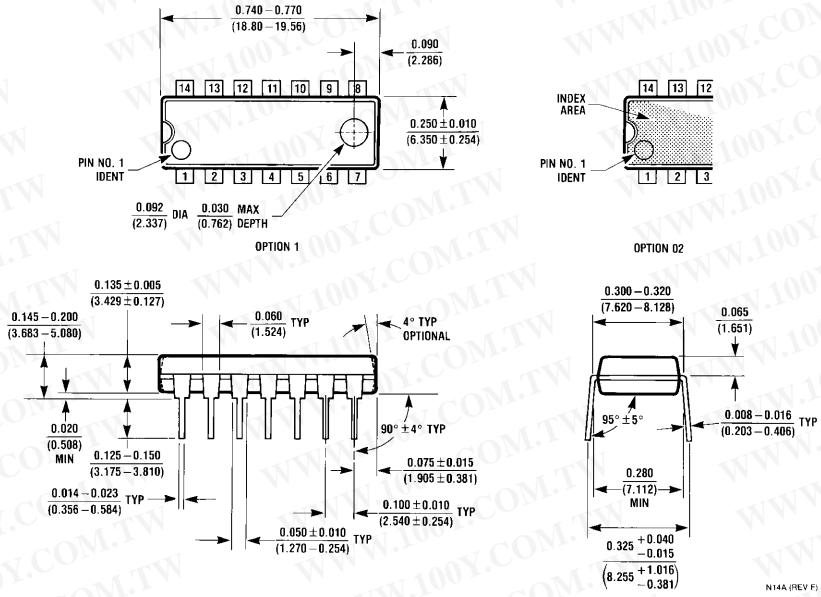

14-Lead Plastic Dual-In-Line Package (PDIP), JEDEC MS-001, 0.300" Wide Package Number N14A

Fairchild does not assume any responsibility for use of any circuitry described, no circuit patent licenses are implied and Fairchild reserves the right at any time without notice to change said circuitry and specifications.

LIFE SUPPORT POLICY

FAIRCHILD'S PRODUCTS ARE NOT AUTHORIZED FOR USE AS CRITICAL COMPONENTS IN LIFE SUPPORT DEVICES OR SYSTEMS WITHOUT THE EXPRESS WRITTEN APPROVAL OF THE PRESIDENT OF FAIRCHILD SEMICONDUCTOR CORPORATION. As used herein:

1. Life support devices or systems are devices or systems which, (a) are intended for surgical implant into the body, or (b) support or sustain life, and (c) whose failure to perform when properly used in accordance with instructions for use provided in the labeling, can be reasonably expected to result in a significant injury to the user.
2. A critical component in any component of a life support device or system whose failure to perform can be reasonably expected to cause the failure of the life support device or system, or to affect its safety or effectiveness.