

**MODEL CD-W552GB-xxx
CD-RW DRIVE**

HARDWARE SPECIFICATION

Rev. D

27 sheets in Total

勝特力材料 886-3-5753170
勝特力电子(上海) 86-21-34970699
勝特力电子(深圳) 86-755-83298787
[Http://www.100y.com.tw](http://www.100y.com.tw)

TABLE OF CONTENTS

Title	Page
1. SCOPE	1
2. OUTLINE	1
3. CONSTRUCTION	2
3.1 External Construction	2
3.2 Front Bezel	3
3.3 Installation	4
4. DISC SPECIFICATION	5
4.1 Applicable Disc Formats	5
4.2 Rotational Speed	5
4.3 Data Capacity	6
4.4 Write Methods	6
5. PERFORMANCE	7
5.1 Operating Performance	7
5.2 Mechanism	8
5.3 Audio	8
5.3.1 Line output	8
6. ENVIRONMENTAL CONDITIONS	10
6.1 Ambient Temperature/relative Humidity	10
6.2 Vibration	10
6.3 Shocks	11
6.4 Noise	11
6.5 Transportation Condition	11
7. RELIABILITY	12
7.1 General	12
7.2 Safety and EMC Standards	12
8. INDICATOR AND STRAP FUNCTIONS	13
8.1 Indicator	13
8.1.1 Location	13
8.1.2 Indicator function	13
8.2 Strap	13
8.2.1 CSEL bypass (3), slave (2), master (1)	13
9. FRAME GROUNDING	14
10. POWER INTERFACE	14
10.1 Power Supply Used	14
10.2 Current Consumption	14
10.3 Power Supply Sequence	15
10.4 Power Interface Connector and Cable	15
11. IDE HARDWARE INTERFACE	17
11.1 Applicable Standard	17
11.2 Electrical Characteristics	17
11.3 Signal Interface Connector and Cable	18
12. REQUESTS RELATING TO THE FCC RULE PART (15) AND SAFETY LASER PRODUCTS	
19	
12.1 FCC Rule Part (15)	19
12.2 Safety of Laser Products	20
13. LABEL USED	21
14. PACKAGING	23

1. SCOPE

This is hardware specification of the TEAC CD-W552GB-xxx CD-RW drive (hereinafter referred to as CD-RW drive or drive).

2. OUTLINE

The outline of this CD-RW drive is given in [Table 2-1](#).

(Table 2-1) Outline of the specification

Model name	CD-W552GB-xxx
TEAC P/N	1977151x-xx
Applicable safety and EMC standards	UL, CSA, TÜV, NEMKO, CB, FCC, CE, C-tick, BSMI Refer to 7.2 for details.
Data transfer rate	16.6MB/s, 33.3MB/s at the maximum
Data capacity	650MB
Access time	120ms Max. (at Random access)
Disc speed	10,300rpm Approx. (during CD-ROM reading mode)
Signal interface	IDE (ATAPI)
Power source	+5Vdc, +12Vdc
Power consumption	26W Max
Disc loading method	Disc tray
Start time	15sec or less
Applicable disc format	Refer to 4.1 .
Write method	Disc-at-once, Track-at-once, Session-at-once, Packet write
Buffer underrun prevention function	Provided
Readable disc	Press CD, written CD-R/RW disc
Front bezel and escutcheon	Refer to Table 3.2-1 .
Eject button	
Tray	Green (Refer to Table 8.1.2-1 .)
Front indicator color	
Audio lineout	0.85 ±0.15Vrms, 47kΩ
Default strap setting	Master
Laser class	Class 1 laser product

3. CONSTRUCTION

3.1 External Construction

(1) External Dimensions

The external dimensions shall satisfy the specifications given in Fig.3.1-1.

(2) Weight : 0.7kg typ

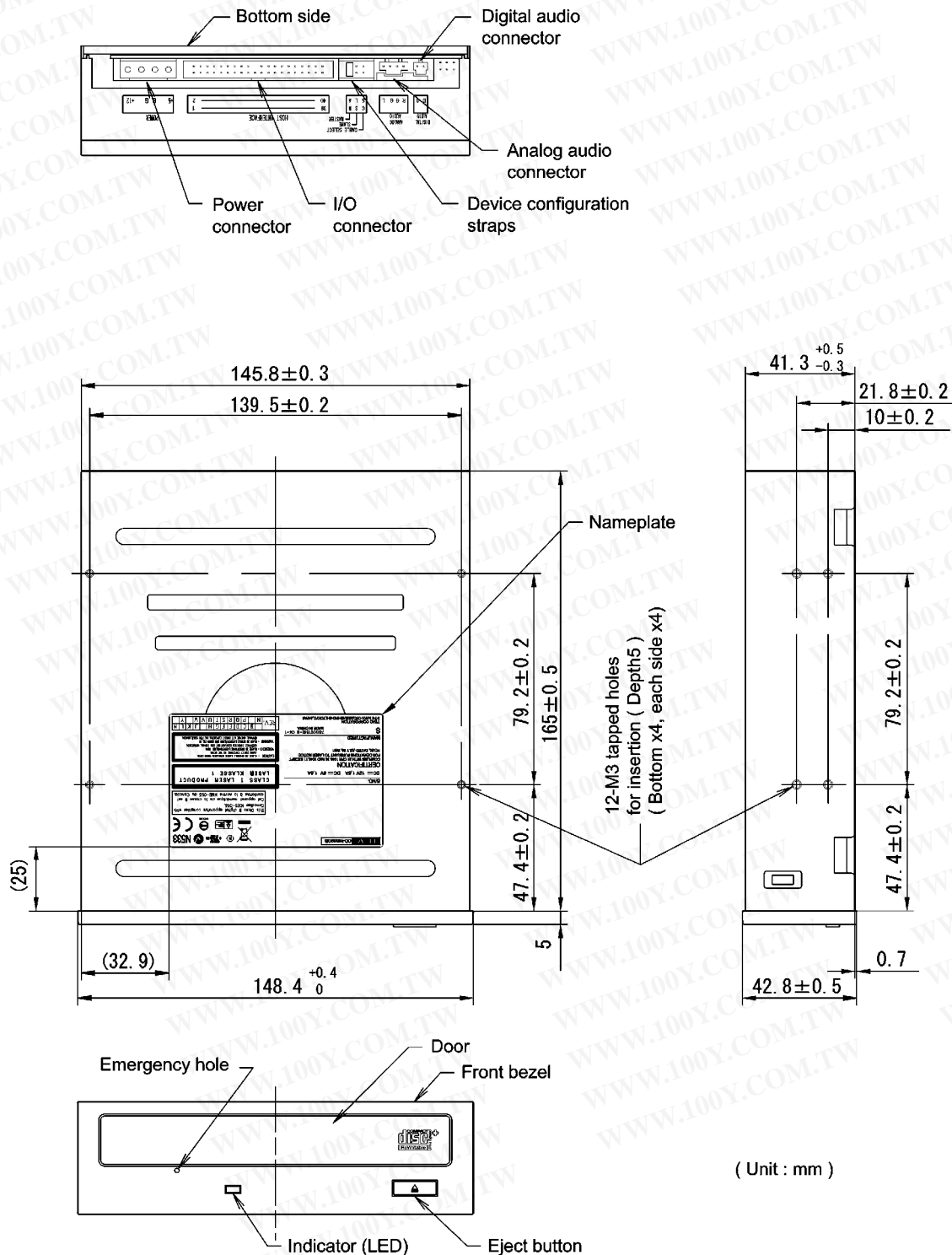

(Fig. 3.1-1) External view of the drive

3.2 Front Bezel

(1) The color of the front bezel, the escutcheon, the tray and volume are shown in Table 3.2-1.

(Table 3.2-1) Color and Logo marks

Version	Color				Logo	
	Bezel	Door	Eject button	Tray	TEAC	X52
-000	Black	Black	Black	Black	No	No
-002	PS2	PS2	PS2	PS2	No	No
-038	Light gray	Light gray	Light gray	PS2	No	No
-050	Silver	Silver	Silver	PS2	No	No
-095	PS2	PS2	PS2	PS2	Yes	Yes

(2) The logo mark indication is shown in Fig.3.2-1 and Fig.3.2-2.

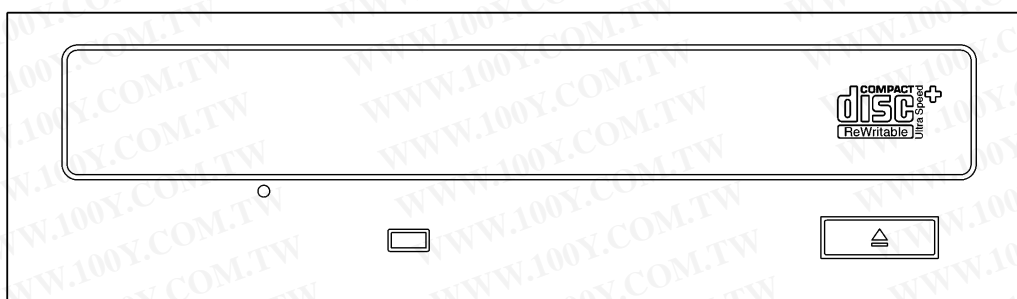

(Fig. 3.2-1) Front bezel without the logo marks indicated



(Fig. 3.2-2) Front bezel with the logo marks indicated

3.3 Installation

The drive operation specification shall be satisfied with the installation method described below.

(1) Installation direction

The drive operation specification shall be satisfied using the following two drive positions.

(a) Position where the disc is placed horizontally.

Note : The front indicator shall be in the left side. The tilt shall be 10° or less in all directions.

(b) Position where a disc is vertical. The tilt shall be 10° or less in all directions.

(2) Mounting method

The mounting holes at the drive side and bottom shall be used for mounting (See Fig.3.1-1).

(a) Screw hole: Left side 4-M3

Right side 4-M3

Bottom side 4-M3

(b) Tightening torque : 0.294 to 0.49 N-m (3 to 5kg-cm)

(c) Screw insertion depth : 5mm or less

4. DISC SPECIFICATION

4.1 Applicable Disc Formats

The read and write of the following disc formats apply to the drive.

(Table 4.1-1) Applicable disc formats

Format	Read capability	Write capability
CD-DA	Yes	Yes
CD-ROM Mode1	Yes	Yes
CD-ROM XA Mode2 (Form1, Form2)	Yes	Yes
CD-I	Yes	Yes
Mixed mode CD-ROM	Yes	Yes
Photo CD	Yes	Yes
CD-Extra	Yes	Yes
Video CD	Yes	Yes
CD-Text	Yes	Yes

4.2 Rotational Speed

The rotational speed in each mode shall be in accordance with Table 4.2-1, Table 4.2-2 and Table 4.2-3.

(Table 4.2-1) Rotational speed (Read mode)

Media	Normal read speed
CD-ROM	23x - 52x (F-CAV)
CD-DAE	23x - 52x (F-CAV)
Video CD	13x - 32x (F-CAV)
Finalized CD-R Data	23x - 52x (F-CAV)
Finalized CD-RW	16x - 40x (F-CAV)
Un-Finalized CD-R	10x - 24x (F-CAV)
Un-Finalized CD-RW	10x - 24x (F-CAV)

(Table 4.2-2) Rotational speed (Playback mode)

Media	Normal playback speed
CD-DA	6x - 16x (F-CAV)
Video CD	6x - 16x (F-CAV)

(Table 4.2-3) Rotational speed (Write mode)

Media type	Selection speed	Write speed
CD-R	52x	23x - 52x (F-CAV)
	48x	21x - 48x (F-CAV)
	40x	18x - 40x (F-CAV)
	32x	18x - 32x (P-CAV)
	24x	18x - 24x (P-CAV)
	16x	16x (F-CLV)
	12x	12x (F-CLV)
Multi speed CD-RW	4x	4x (F-CLV)
High speed CD-RW	12x	12x (F-CLV)
	10x	10x (F-CLV)
	4x	4x (F-CLV)
Ultra speed CD-RW	24x	16x - 24x (Z-CLV)
	16x	16x (F-CLV)
Ultra speed+ CD-RW	32x	16x - 24x - 32x (Z-CLV)
	24x	16x - 24x (Z-CLV)
	16x	16x (F-CLV)

4.3 Data Capacity

Data capacity shall be in accordance with [Table 4.3-1](#) for each disc format.

(Table 4.3-1) Data capacity

Disc formats	Applicable capacity
CD-ROM Mode1 CD-ROM XA Mode 2 Form 1	650MB / 700MB
CD-ROM XA Mode 2 Form 2	738MB / 795MB
CD-DA	74min / 79min

4.4 Write Methods

(Table 4.4-1) Write methods

Media	Write methods
CD-R	Disc-at-Once (DAO), Session-at-Once (SAO), Track-at-Once (TAO), Variable Packet, Fixed Packet
CD-RW	

5. PERFORMANCE

5.1 Operating Performance

(1) Access time

The performance specified in [Table 5.1-1](#) applies to the access time of the drive.

(Table 5.1-1) Access time

Access mode	Max (msec)	Remarks
Random access	120	00m02s00f ~ 59m58s74f, 100 times on the average
1/3 stroke access	120	20m02s00f ~ 40m02s00f, 100 times on the average
Full stroke access	200	00m02s00f ~ 59m58s74f, 100 times on the average

(2) Rotational speed

10,300rpm Approx. (during CD-ROM reading mode)

(3) Data transfer rate (asynchronous)

The performance specified in [Table 5.1-2](#) applies to the data transfer rate in each mode of the drive.

(Table 5.1-2) Transfer rate

Mode	Avg. (MB/s)	Max (MB/s)	Remarks
Program I/O	–	16.6	Default value PIO MODE 4
Burst DMA	–	16.6	Default value MW DMA MODE 2
Burst UDMA	–	33.3	Default value ULTRA DMA MODE 2

(4) Start/ stop time

The performance specified in [Table 5.1-3](#) applies to the start/stop time of the drive.

(Table 5.1-3) Start/stop time

	Media	Max (sec)	Remarks
Start time	12cm	15	Including Tray in, spin up and read TOC
	8cm	15	↑
	Photo CD	15	3 sessions
Stop time	All media	9	Including Spin down and tray out

(5) Data buffer capacity

2MB in all operation modes

5.2 Mechanism

(1) Loading mechanism

(a) TRAY loading method

- Automatic loading with the eject button
- Automatic loading with the press of the tray
- Automatic loading with the interface command

(b) TRAY ejection method

- Automatic ejection with the eject button
- Automatic ejection with the interface command

Manual ejection with the emergency hole (used with the emergency power off)

(2) Disc Loading/ejection Method

- (a) When inserting a disc, place it on the tray from the back side first and the front side is pressed to the tray lightly. Or place the front side of it on the tray first, then pull toward the front to set it.
- (b) When taking out the disc, pull it toward the top direction without applying excessive force.
- (c) An 8cm disc can be used by placing it on the specified center position described in “3.2 Installation” when the drive is in a horizontal position. Then the disc position should not be shifted when ejecting the tray. It cannot be used when the drive is in a vertical position.

5.3 Audio

5.3.1 Line output

(1) Performance

The performance specified in Table Table 5.3.1-1 applies to the line output of the drive.

(Table 5.3.1-1) Line output performance
(Type: imbalance, Channel: 2 channels, L/R stereo)

Item		Min	Typ	Max	Unit	Remarks
Analog	Level	0.70	0.85	1.00	Vrms	1kHz, ATT 0dB, Load: 47kΩ
	Frequency characteristics	-3.5	0	+3.5	dB	20~20kHz
	Distortion factor	—	—	0.1	%	1kHz, 20kHz LPF
	SNR	65	—	—	dB	1kHz, IHFA
	Channel separation	65	—	—	dB	1kHz, 20kHz LPF
	Dynamic range	65	—	—	dB	1kHz, IHFA
	Volume	-∞	—	0	dB	256 steps, variable independently for L and R channels
Digital	Digital output	3.3			Vp-p	SPDIF Standard

(2) Connector

Pin assignment: Refer to [Table 5.3.1-2](#) and [Table 5.3.1-3](#).**(Table 5.3.1-2) Analog audio output connector pin assignment**

No.	Signal
1	L channel signal output
2	GND
3	GND
4	R channel signal output

(Table 5.3.1-3) Digital audio output connector pin assignment

No.	Signal
G	GND
D	Digital output

6. ENVIRONMENTAL CONDITIONS

The environmental conditions specified in this item apply to the drive excluding the disc.

The environmental conditions for discs shall be in accordance with the applicable specification.

6.1 Ambient Temperature/relative Humidity

The conditions specified in Table 6.1-1 apply to the drive.

(Table 6.1-1) Ambient temperature/ relative humidity conditions

Drive state	Item	Min	Typ	Max	Unit	Remarks
During operation	Ambient temperature	5	–	45	°C	Non-condensation, 12°C/ hour or less 10%RH/ hour or less during write operation
	Relative humidity	20	–	80	%RH	
	Wet-bulb temperature	–	–	29	°C	
During non-operation	Ambient temperature	–20	–	60	°C	Non-condensation, 25°C/ hour or less 10%RH/ hour or less
	Relative humidity	15	–	85	%RH	
	Wet-bulb temperature	–	–	32	°C	
During transportation (in package)	Ambient temperature	–40	–	65	°C	Non-condensation, 25°C/ hour or less 20%RH/ hour or less
	Relative humidity	5	–	90	%RH	
	Wet-bulb temperature	–	–	32	°C	

6.2 Vibration

The conditions specified in Table 6.2-1 apply to the drive.

(Table 6.2-1) Vibration condition

Drive state	Test conditions		Requirements
During operation	Acceleration	2.94m/s ² (0.3G)	No error shall occur during operations excluding write operation.
	Frequency	5 ~ 500Hz	
	Scanning duration	1oct/min	
	Test duration	5min/ one direction (Vibrations applied in three directions)	
During non-operation	Acceleration	19.6m/s ² (2.0G)	The drive shall be free from any damage after the test.
	Frequency	10 ~ 500Hz	
	Scanning duration	1oct/min	
	Test duration	20min/ one direction (Vibrations applied in three directions)	
During transportation (in package)	X direction	5 ~ 300Hz, 9.80m/s ² (1.00G), 30min	The drive shall operate normally after each cycle test.
	Y direction		
	Z direction		

6.3 Shocks

The conditions described in [Table 6.3-1](#) apply to the drive.

(Table 6.3-1) Shock conditions

Drive condition		Test conditions			Requirement
		Acceleration	Pulse wave	Number of Pulses	
During operation	CD-ROM	49.0m/s ² (5G)	11msec (half-sine wave)	5 times in the directions of X, Y and Z axes	Shall be free from any errors during operation.
	CD-DA	19.6m/s ² (2G)			
	CD-R/RW	9.8m/s ² (1G)			
During non-operation		490m/s ² (50G)		1 time per each surface	Shall be free from damage after test.
During transportation		Height	60cm (72cm: Bottom face only)		Shall be free from damage after test.
		Direction	1 corner, 3 edges, 6 surfaces		

6.4 Noise

The conditions described in [Table 6.4-1](#) apply to the drive.

(Table 6.4-1) Noise conditions

Specification	Remarks
55dBA or less (sound pressure)	At a distance of 50cm from the drive excluding the load and eject operations. The 0.25 imbalance disc shall be used.

6.5 Transportation Condition

The drive package shall conform to the Appropriate Package Test Level 2 specified in JIS-Z0200 when using the specified packing box.

7. RELIABILITY

7.1 General

- (1) MTBF : 70,000POH (at normal temperature and humidity; duty 25%)
- (2) MTTR : 30 minutes, typical
- (3) Data read error rate : Block/10¹² bits (MODE1 and MODE2 Form1)
Block/10⁹ bits (MODE2 Form2 and CD-DA)
- (4) Seek mechanism life : 1,000,000 times
- (5) Loading/ eject life : 10,000 times
- (6) Designed life : 5 years

7.2 Safety and EMC Standards

The standards with which the drive complies are shown below.

Refer to Fig.13-1 and Fig.13-2 for the nameplate used.

(Table 7.2-1) Safety standard

Safety standard	Standard No.
UL	UL60950-1
CSA	CAN/CSA-C22.2, No. 60950-1
TÜV	EN60950-1, EN60825-1
NEMKO	EN60950
CB-Scheme	IEC60950-1, IEC60825-1

(Table 7.2-2) EMC standard

EMC standard	Standard No.
FCC (USA)	Part 15 Class B, CISPR22 Class B
CE (European)	EN55022 Class B, EN55024, EN61000-3-2, EN61000-3-3
C-tick (Austria)	AS/NZS CISPR 22 Class B
BSMI (Taiwan)	CNS 13438 Class B

8. INDICATOR AND STRAP FUNCTIONS

8.1 Indicator

8.1.1 Location

The indicator is located below the left side of the disc insertion slot on the front bezel.

8.1.2 Indicator function

The following indicator functions apply to each LED of the drive.

(Table 8.1.2-1) Functions of indicator

Operation mode	Indicator
During read/Data transfer	Green LED lights.
During write	Green LED lights.
During audio play	Green LED lights.
During seek	Green LED does not light.
At start (Power ON of PC)	Green LED blinks after lighting once.
When the tray is opened/closed	Green LED does not light.
When Buffer Under Run occurs	Green LED does not change.

8.2 Strap

Refer to Fig.10.4-1 for the location and alignment of the strap.

8.2.1 CSEL bypass (3), slave (2), master (1)

Refer to Table 8.2.1-1 for each strap setting.

(Table 8.2.1-1) Strap setting

3	2	1	Setting contents
Short	Open	Open	Master or slave is set using the CSEL terminal.
Open	Short	Open	Slave
Open	Open	Short	Master

9. FRAME GROUNDING

The drive frame is electrically connected to 0Vdc.

10. POWER INTERFACE

10.1 Power Supply Used

The following specification applies to the power interface connector terminals of the drive. The voltage applied to the power terminal shall be defined in Table 10.1-1 and the drive shall operate normally with the voltage.

(Table 10.1-1) Power voltage specification

	+5V system	+12V system
Operating voltage range	±5% (4.75 ~ 5.25V)	±5% (11.4 ~ 12.6V)
Allowable ripple	100mVp-p or less	200mVp-p or less

10.2 Current Consumption

The following current consumption specifications apply to the drive..

(Table 10.2-1) Current consumption (excluding pulses of 10ms or less)

Operation	+5V		+12V	
	Typ	Max	Typ	Max
During read	0.72A	1.2A	0.96A	1.2A
During seek	0.8A	1.5A	0.6A	1.2A
During spin up	0.75A	1.0A	0.75A	1.4A
While idling	0.6A	0.8A	0.18A	0.2A
During sleep	0.09A	0.2A	0.001A	0.01A
During loading/ ejection	0.9A	1.2A	1.4A	1.5A
During write	0.8A	1.2A	0.6A	1.0A

10.3 Power Supply Sequence

The drive shall operate normally with the power supply sequence specified in Fig.10.3-1 and Table 10.3-1.

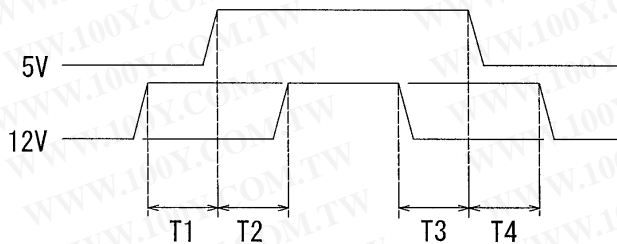

(Fig. 10.3-1) Power supply sequence

(Table 10.3-1) Power supply sequence specifications

	Specifications	Remarks
T1, T2, T3, T4	50msec Max	

10.4 Power Interface Connector and Cable

- (1) Power interface connector
 - (a) Number of poles: 4 poles
 - (b) Protection method for mis-insertion : by the shape of the connector housing
 - (c) Connector terminal diagram : Refer to Fig.10.4-1.
 - (d) Connector location : Refer to Table 10.4-1.
 - (e) Pin assignment : Refer to Table 10.4-1.

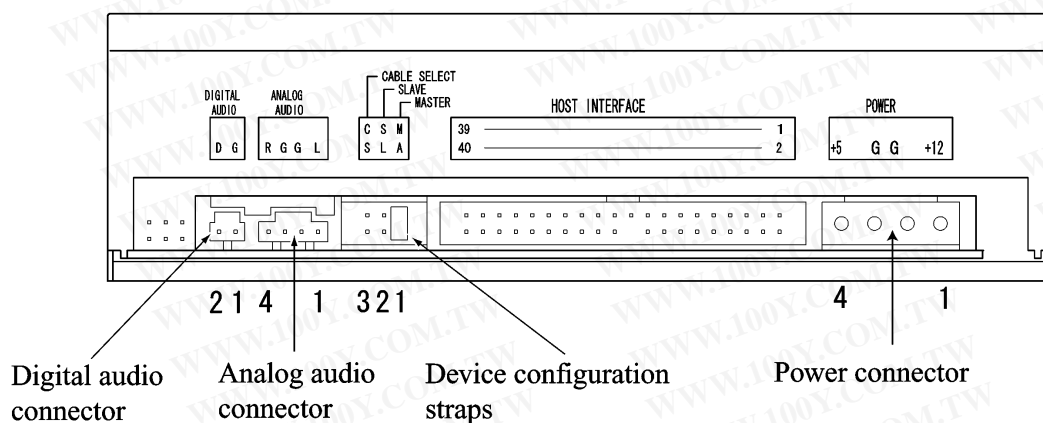

(Fig. 10.4-1) External view of the rear

(Table 10.4-1) Power interface connector pin assignment

No.	Input terminal name
1	+12V input terminal
2	GND
3	GND
4	+5V input terminal

11. IDE HARDWARE INTERFACE

11.1 Applicable Standard

ANSI	: ATA-6 compliant
SFFC	: SFF-8090 V5 compliant

11.2 Electrical Characteristics

The following specification applies to the drive interface connector terminals for the IDE interface signal. The input signal indicates a signal input to the drive and the output signal indicates a signal output from the drive.

(Table 11.2-1) Electrical characteristics of input/ output signals

Signal	Input/output	Item	Min	Typ	Max	Unit	Remarks
3-state input/output signal DD0 ~ DD15	Input	Low level	-0.3		0.8	Vdc	
		High level	2		5.25	Vdc	
		Input current	12			μA	
	Output	Low level	-0.3		0.5	Vdc	Output sync current 12mA
		High level	2.4		3.6	Vdc	Output source current 4mA
Damping resistor			33			Ω	DD0 ~ DD15
3-state input/output signal -PDIAG, -DASP	Input	Low level	-0.3		0.8	Vdc	
		High level	2		3.6	Vdc	
		Input current	-10		10	μA	Excluding pull-up resistance
	Output	Low level	-0.3		0.5	Vdc	Output sync current 12mA
		High level	2.4		3.6	Vdc	Output source current 4mA
Pull-up resistor			10			kΩ	-PDIAG, -DASP
3-state output signal DMARQ, INTRQ -IORDY, -IOCS16	Output	Low level	-0.3		0.5	Vdc	Output sync current 12mA
		High level	2.4		3.6	Vdc	Output source current 4mA
Damping resistor			22			Ω	DMARQ, INTRQ -IORDY
Input signal -DLOW, -DIOR, CSEL, -RESET, -DMACK DA0 ~ DA2, -CS0, -CS1	Input	Low level	-0.3		0.8	Vdc	
		High level	2		3.6	Vdc	CSEL
		Input current	-10		10	μA	Excluding pull-up resistor
	Pull-up resistance			40			kΩ
Damping resistor			82			Ω	All the signals described on the left
Input signal -DMACK	Input	Low level	-0.3		0.8	Vdc	
		High level	2		3.6	Vdc	
		Input current	-10		10	μA	
	Pull-up resistor			40			kΩ

11.3 Signal Interface Connector and Cable

(1) Signal interface connector

- (a) Number of pins and pitch : 2.54mm (0.1 in) pitch
20 pins × 2 rows (40 pins)
- (b) Connector pin diagram : Refer to Fig.10.4-1.
- (c) Connector layout : Refer to Fig.10.4-1.
- (d) Connector pin-assignment table : Refer to Table Table 11.3-1.

(2) Signal interface cable

- (a) Type : 40-conductor flat cable
- (b) Conductor size : AWG28 or more
- (c) Characteristic impedance : $100\Omega \pm 10\%$ (recommended)
- (d) Maximum cable length : 0.46m

(Table 11.3-1) Signal interface pin-assignment table

No.	Signal	No.	Signal
1	-RESET	2	GND
3	+DD7	4	+DD8
5	+DD6	6	+DD9
7	+DD5	8	+DD10
9	+DD4	10	+DD11
11	+DD3	12	+DD12
13	+DD2	14	+DD13
15	+DD1	16	+DD14
17	+DD0	18	+DD15
19	GND	20	(KEY)
21	+DMARQ	22	GND
23	-DIOW	24	GND
25	-DIOR	26	GND
27	+IORDY	28	CSEL
29	-DMACK	30	GND
31	+INTRQ	32	-IOCS16
33	+DA1	34	-PDIAG
35	+DA0	36	+DA2
37	-CS0	38	-CS1
39	-DASP	40	GND

Remarks : The plus mark in the signal column indicates high-level true signal and the minus mark, low-level true signal.

12. REQUESTS RELATING TO THE FCC RULE PART (15) AND SAFETY LASER PRODUCTS

12.1 FCC Rule Part (15)

When selling this unit directly to an end user, print the following text in the instruction manual or enclose the separate sheet on which the following text is printed with the instruction manual.

Declaration of Conformity

Model Number : CD-W552GB-xxx
Trade Name : TEAC
Responsible party : TEAC AMERICA, INC.
Address : 7733 Telegraph Road, Montebello, California, U.S.A.
Telephone Number : 1-213-726-0303

This device complies with Part 15 of the FCC Rules. Operation is subject to the following two conditions : (1) This device may not cause harmful interference, and (2) this device must accept any interference received, including interference that may cause undesired operation.

TO THE USER

This equipment has been tested and found to comply with the limits for a Class B digital device, pursuant to Part 15 of the FCC Rules. These limits are designed to provide reasonable protection against interference in a residential areas. This device generates and uses radio frequency energy and if not installed and used in accordance with the instructions, it may cause interference to radio or TV reception. If this unit does cause interference with TV or radio reception you can try to correct the interference by one more of the following measures:

- a) Reorient or relocate the receiving antenna.
- b) Increase the separation between the equipment and receiver.
- c) Connect the equipment into an outlet on a circuit different from that to which the receiver is connected.
- d) Consult the dealer or an experienced radio/TV technician for help.

CAUTION:

Changes or modifications to this equipment not expressly approved TEAC CORPORATION for compliance could void the user's authority to operate this equipment.

12.2 Safety of Laser Products

When selling this unit or a system with this unit to an end user, print the following text in the instruction manual or enclose the separate sheet on which the following text is printed with the instruction manual.

This product has been designed and manufactured according to FDA regulations "title 21. CFR. chapter1, subchapter J. based on the radiation Control for Health and Safety Act of 1968", and is classified as a class 1 laser product. There is no hazardous invisible laser radiation during operation because invisible laser radiation emitted inside of this product is completely confined in the protective housings.

The label required in this regulation is shown bellow.

CAUTION
Use of controls or adjustments or performance of procedures other than those specified herein may result in hazardous radiation exposure.

Optical pickup	
Type	: SF-W37S
Manufacturer	: SANYO
Laser output	: 1.5mW (Read), 74mW (Write)
Wavelength	: 783nm

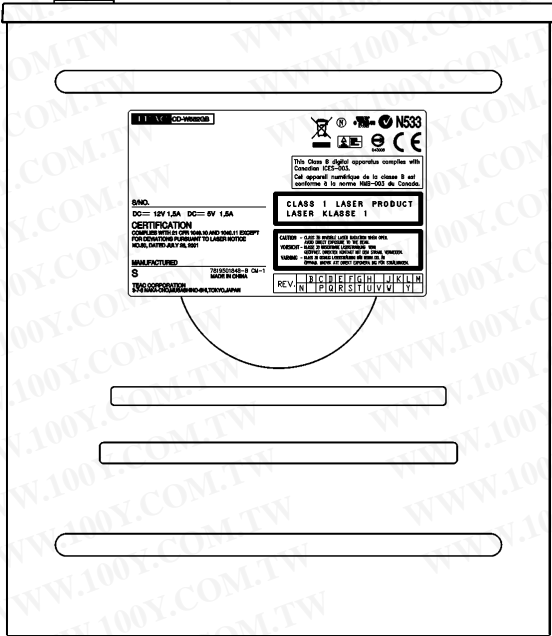

13. LABEL USED

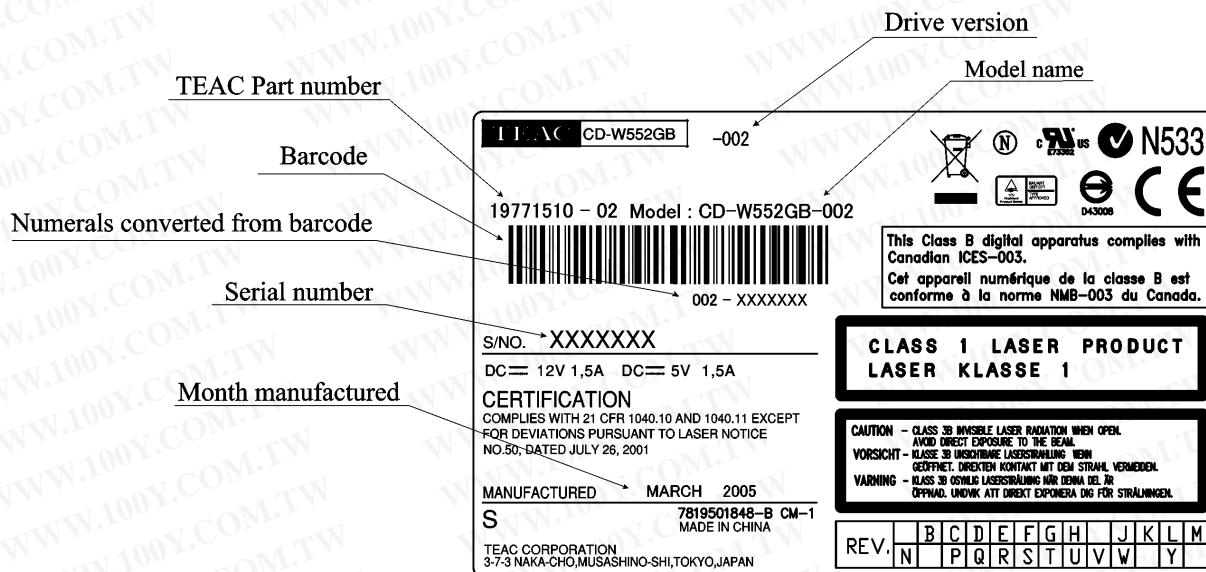

(Fig. 13-1) Nameplate

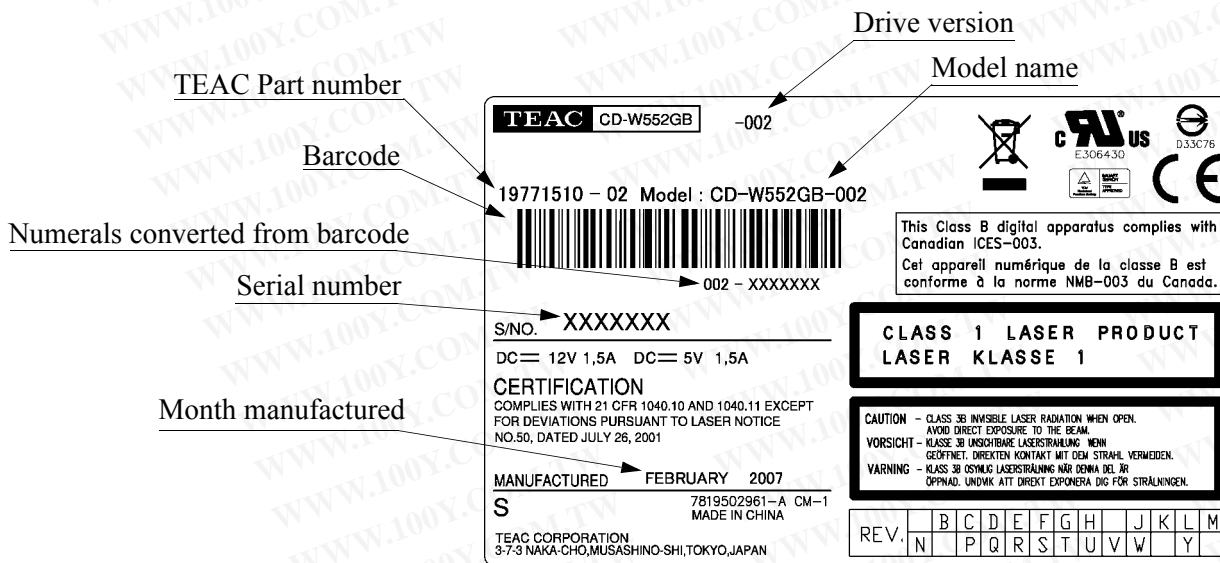

(Fig. 13-2) Nameplate (for the drive that does not comply with NEMKO and C-tick)

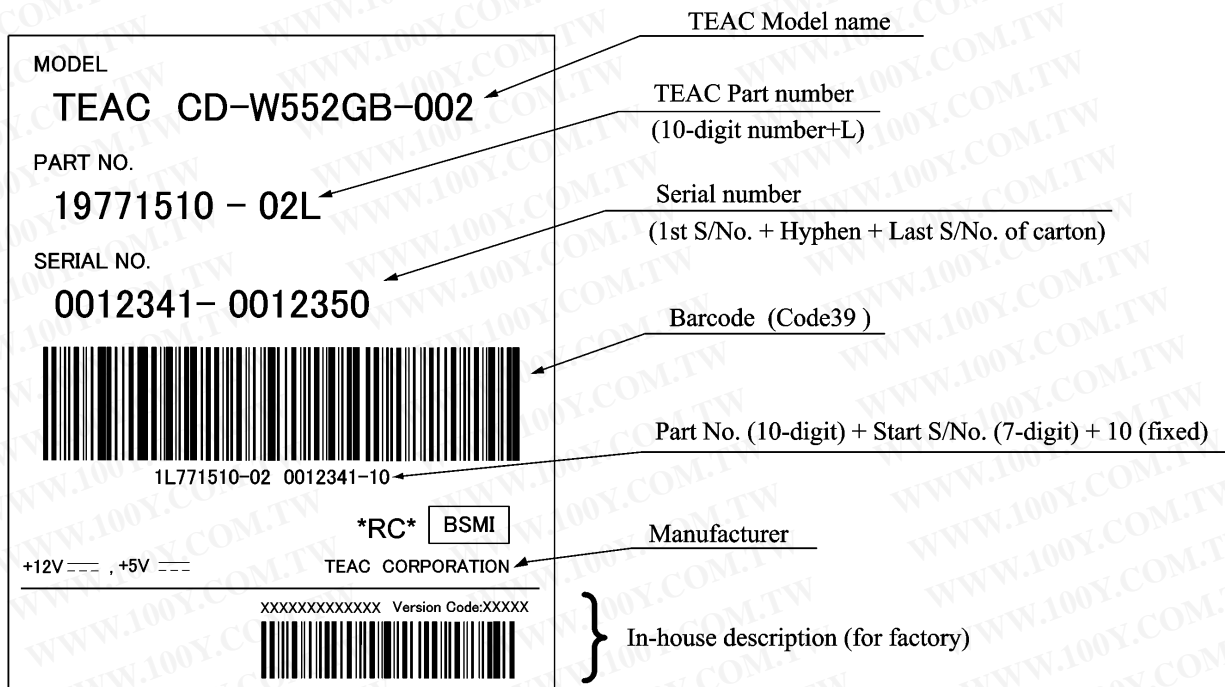

(Fig. 13-3) Carton label

14. PACKAGING

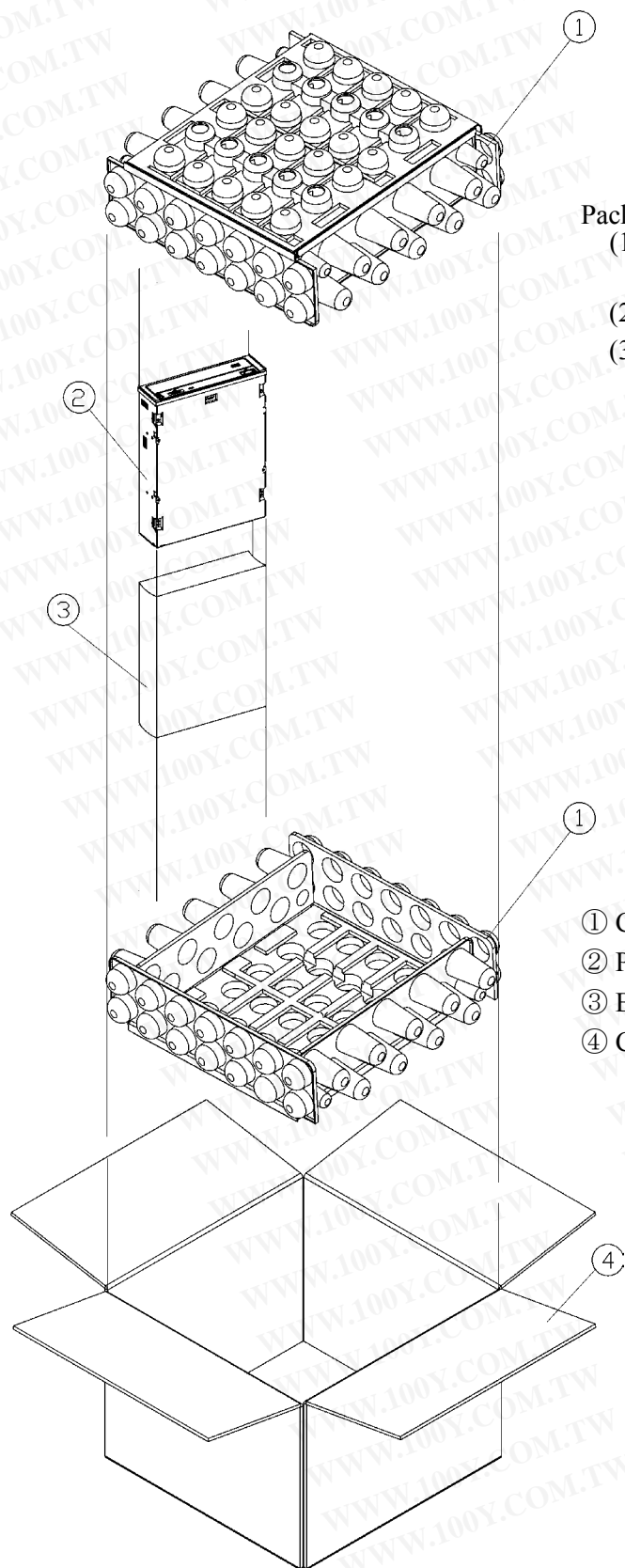

Packaging:

- (1) Outline dimensions of carton :
363(L)×363(W)×244(H)mm
- (2) Packed quantity in one package : 10 sets
- (3) Weight for one package : G.W.8.4kgs, typ

- ① Cushion, PMP (2 EA/Carton)
- ② Products (10 sets/Carton)
- ③ Bubble bag, drive (10 pcs/Carton)
- ④ Carton, Bulk (1EA/Carton)

(Fig. 14-1) Aggregate package

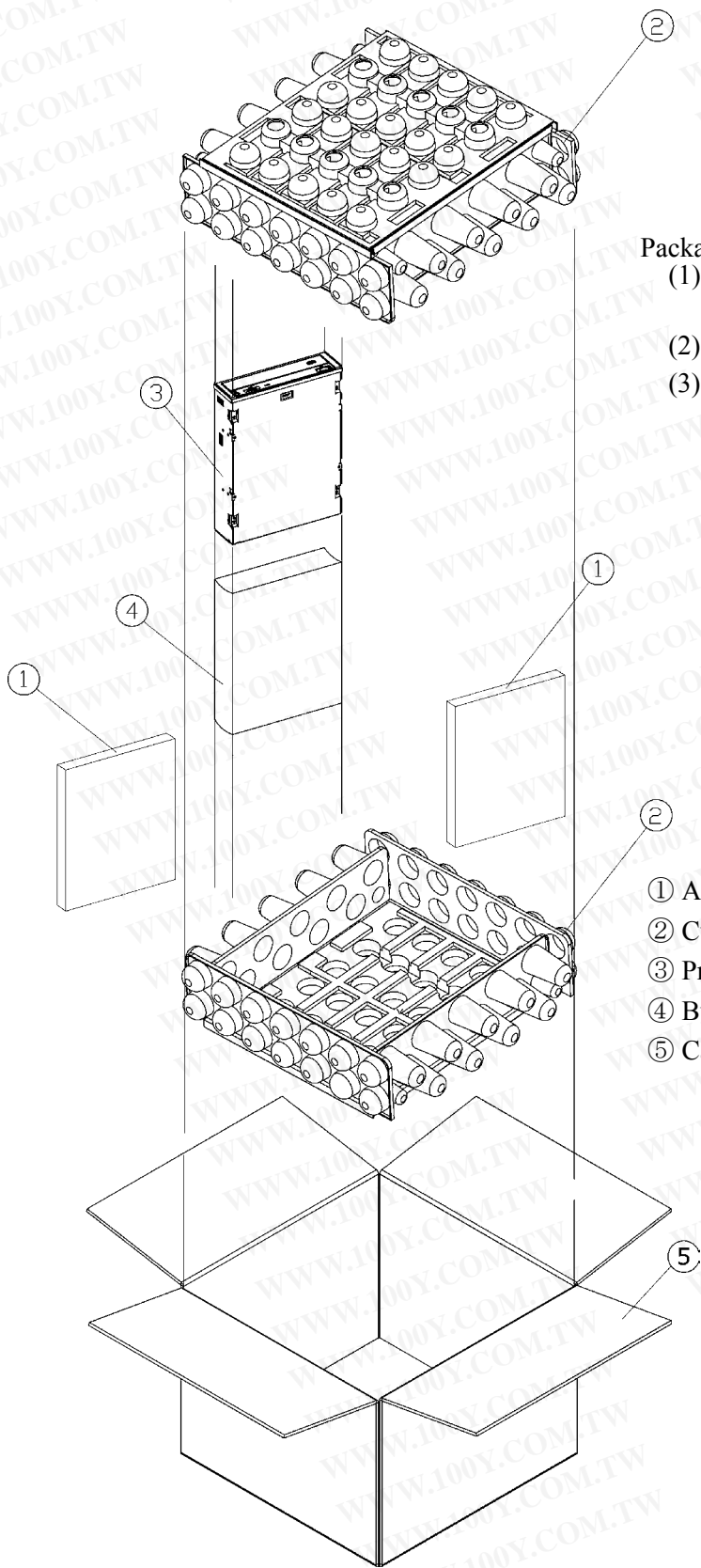

Packaging:

- (1) Outline dimensions of carton :
363(L)×363(W)×244(H)mm
- (2) Packed quantity in one package : 10 sets
- (3) Weight for one package : G.W.8.4kgs, typ

- ① Accessory (2×5 sets/carton)
- ② Cushion, PMP (2 EA/carton)
- ③ Products (10 sets/carton)
- ④ Bubble Bag, Drive (10 pcs/carton)
- ⑤ Carton, Bulk (1EA/Carton)

(Fig. 14-2) Aggregate package (contains Accessory)

Carton label
(2pcs per Carton)

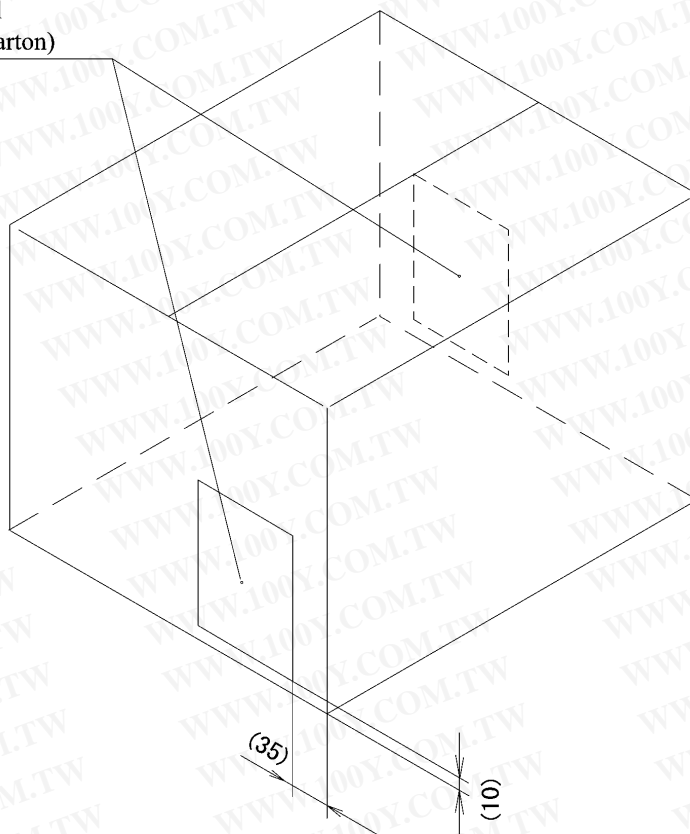

(Fig. 14-3) Label attaching position on the packing box