

BC05 • BC05A

FEATURES

- 10V TO 200V MOTOR SUPPLY AT 5A CONTINUOUS AND 10A PEAK OUTPUT CURRENT
- OPERATION WITH 10.8V TO 16V VCC, ALLOWING NOMINAL 12V OR 15 V VCC SUPPLIES
- THREE PHASE FULL BRIDGE OPERATION WITH 2 OR 4 QUADRANT PWM
- AUTOMATIC BRAKING WHEN USING 2 QUADRANT PWM
- THERMAL PROTECTION
- ANTI SHOOT THROUGH DESIGN
- 50 KHZ INTERNALLY SET PWM FREQUENCY, WHICH MAY BE LOWERED WITH EXTERNAL CAPACITORS
- SELECTABLE 60° OR 120° COMMUTATION SEQUENCES
- COMMUTATION TRANSITIONS OUTPUT FOR DERIVING SPEED CONTROL
- MAY BE USED OPEN LOOP, OR WITHIN A FEEDBACK LOOP
- ANALOG MOTOR CURRENT MONITOR OUTPUT, MAY BE USED FOR TORQUE CONTROL OR FOR TRANSCONDUCTANCE AMPLIFIER DRIVE.
- ANALOG REFERENCE, FEEDBACK, AND TORQUE INPUTS

APPLICATIONS

- 3 PHASE BRUSHLESS MOTOR CONTROL

BLOCK DIAGRAM

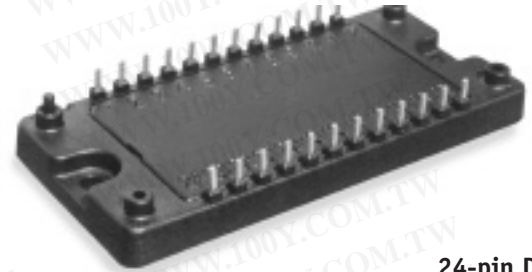
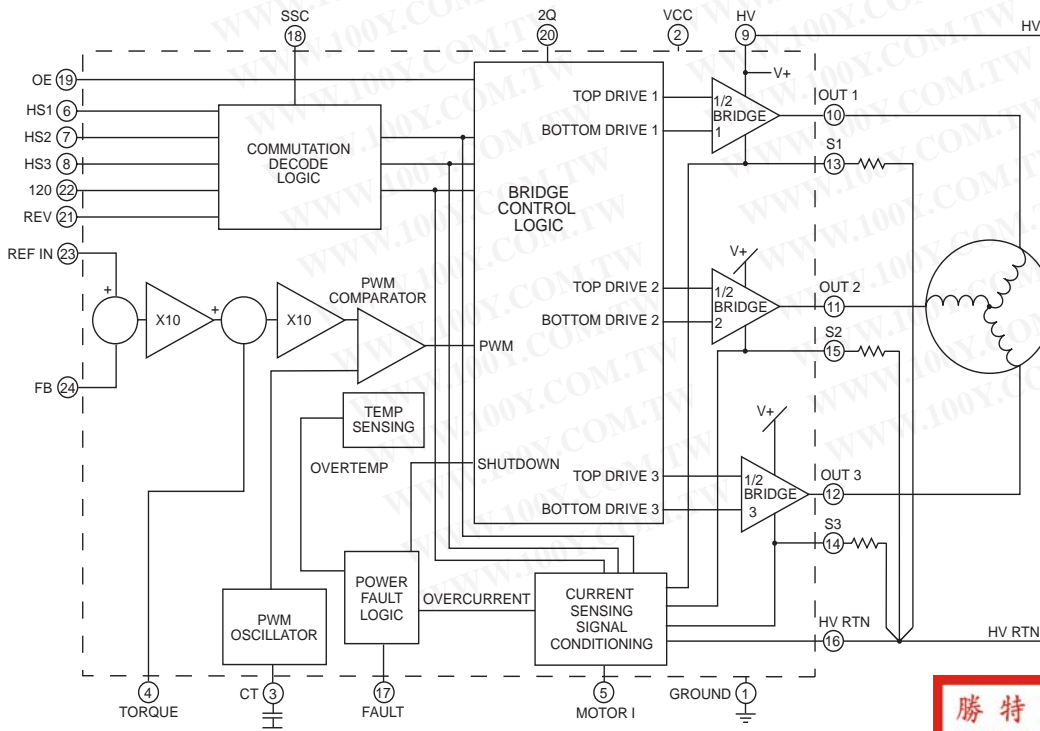

24-pin DIP
PACKAGE STYLE CK

DESCRIPTION

The BC05 Brushless DC Motor Controller provides the necessary functions to control conventional 3-phase brushless DC motors in an open loop or closed loop system. The BC05 is able to control motors requiring up to 1kW continuous input power.

The controller drives the motor, generates the PWM, decodes the commutation patterns, multiplexes the current sense, and provides error amplification. Operation with either 60° or 120° commutation patterns may be selected with a logic input.

Current sense multiplexing is used to make the current monitor output always proportional to the active motor coils current. Therefore the current monitor output may be used in generating transconductance drive for easy servo compensation.

The controller may generate 4-quadrant PWM for applications requiring continuous transition through zero velocity, or 2 quadrant PWM for electrically quieter operation in unidirectional applications.

Direction of rotation may be reversed in 2-quadrant mode by using the reverse command input. When in 2-quadrant mode if the motor is stopped or decelerating dynamic braking is automatically applied. In this way deceleration profiles may be followed even when using 2-quadrant PWM.

BC05 • BC05A

ABSOLUTE MAXIMUM RATINGS
 SPECIFICATIONS

ABSOLUTE MAXIMUM RATINGS

MOTOR VOLTAGE, V+	200V
CIRCUIT SUPPLY, Vcc	16V
OUTPUT CURRENT, peak	10A
OUTPUT CURRENT, continuous	5 A
ANALOG INPUT VOLTAGE	-0.3V to Vcc+0.3V
DIGITAL INPUT VOLTAGE	-0.3V to 5.3V
TEMPERATURE, pin solder, 10s	300°C
TEMPERATURE, junction ²	150°C
TEMPERATURE RANGE, storage	-65 to 150°C
OPERATING TEMPERATURE, case, BC05	-25 to 85°C
OPERATING TEMPERATURE, case, BC05A	-40 to 85°C

SPECIFICATIONS

PARAMETER	TEST CONDITIONS	MIN	TYP	MAX	UNITS
ERROR AMP					
OFFSET VOLTAGE		-3.3	0	3.3	mV
BIAS CURRENT				4	pA
DC GAIN		19.8	20	20.2	db
BANDWIDTH		15	16	17	kHz
INPUT AMP					
STAGE GAIN ¹	Set by internal and/or external resistors		20	20.2	db
INPUT IMPEDANCE ¹			2		Kohm
COMMON MODE VOLTAGE	Applied at input terminals, Vcc = 10.8V	-0.5	5.0	8.5	V
COMMON MODE VOLTAGE	Applied at input terminals, Vcc = 16V	-0.5	5.0	14	V
COMMON MODE REJECTION		50			db
DIFFERENTIAL OFFSET		-3.3	0	3.3	mV
GAIN BANDWIDTH PRODUCT		700			kHz
OUTPUT					
TOTAL R _{on}	Junction Temperature = 125°C		0.65		Ohms
EFFICIENCY, 5A, 200V	Dependent on individual application		93		%
SWITCHING FREQUENCY		45	50	55	kHz
CURRENT, continuous		5			A
CURRENT, peak		10			A
POWER SUPPLY					
VOLTAGE, V+		20		200	V
VOLTAGE, Vcc		10.8		16	V
CURRENT FROM Vcc			250	500	mA
POWER DISSIPATION					
Operating Power Dissipation ²	Calculated at 100V,10A, 50 kHz PWM, 12 mHy, 6.4 ohms, 95% duty cycle and 4-quadrant PWM			124	watts
Single FET Dissipation ²	Calculated at 100V,10A, 50 kHz PWM, 12 mHy, 6.4 ohms 95% duty cycle and 4-quadrant PWM, To each of 6 power FETs, motor stalled			62	watts
Thermal resistance				1.92	°C/watt

- NOTES: 1. Set internally
 2. Long term operation at the maximum junction temperature will result in reduced product life.

CAUTION

The BC05 is constructed from static sensitive components. ESD handling procedures must be observed.

勝特力材料 886-3-5753170
 勝特力电子(上海) 86-21-54151736
 勝特力电子(深圳) 86-755-83298787
[Http://www.100y.com.tw](http://www.100y.com.tw)

TYPICAL PERFORMANCE

BC05 • BC05A

PIN FUNCTION

All Logic Positive TKUC

I/O	SIGNAL	DESCRIPTION	PIN
I	HV	Unregulated high current motor supply voltage	9
I	HVRTN	Return line for the motor current	16
O	OUT1	Half bridge output for driving motor coil	10
O	OUT2	Half bridge output for driving motor coil	11
O	OUT3	Half bridge output for driving motor coil	12
I/O	S1	Source of the N-rail FET in half bridge 1	13
I/O	S2	Source of the N-rail FET in half bridge 2	15
I/O	S3	Source of the N-rail FET in half bridge 3	14
I	HS1	Commutation sensor input 1	6
I	HS2	Commutation sensor input 2	7
I	HS3	Commutation sensor input 3	8
I	120	Sets commutation logic for 120° phasing	22
I	REV	Reverses direction when 2 quadrant PWM is used	21
I	GROUND	Signal ground	1
I	Vcc	Control circuit power	2
I	REF IN	Velocity/speed input	23
I	FB	Input for analog voltage proportional to velocity or speed	24
I	TORQUE	Input for an analog voltage proportional to motor current	4
O	MOTOR I	Analog voltage proportional to motor current	5
O	SSC	HCMOS level pulse for each sensor state change.	18
O	FAULT	HCMOS logic level output, a 1 indicates an over temperature or over current condition.	17
I	OE	HCMOS 1 enables power FET operation	19
I/O	CT	The PWM frequency may be lowered by installing a capacitor between this output and ground.	3
I	2Q	A logic 1 on this input enables 2 quadrant PWM	20

COMMUTATION AND OUTPUT TABLES

TABLE 1

Position	0	60	120	180	240	300
R	0	0	0	0	0	0
2Q	0	0	0	0	0	0
120	1	1	1	1	1	1
OE	1	1	1	1	1	1
HS1	1	1	1	0	0	0
HS2	0	0	1	1	1	0
HS3	1	0	0	0	1	1
OUT1	T	+	+	T	-	-
OUT2	-	-	T	+	+	T
OUT3	+	T	-	-	T	+

TABLE 2

Position	0	60	120	180	240	300
R	0	0	0	0	0	0
2Q	0	0	0	0	0	0
120	0	0	0	0	0	0
OE	1	1	1	1	1	1
HS1	1	1	1	0	0	0
HS2	1	1	0	0	0	1
HS3	1	0	0	0	1	1
OUT1	T	+	+	T	-	-
OUT2	-	-	T	+	+	T
OUT3	+	T	-	-	T	+

TABLE 3

Position	0	60	120	180	240	300
R	0	0	0	0	0	0
2Q	1	1	1	1	1	1
120	1	1	1	1	1	1
OE	1	1	1	1	1	1
HS1	1	1	1	0	0	0
HS2	0	0	1	1	1	0
HS3	1	0	0	0	1	1
OUT1	T	+	+	T	0	0
OUT2	0	0	T	+	+	T
OUT3	+	T	0	0	T	+

TABLE 4

Position	0	60	120	180	240	300
R	0	0	0	0	0	0
2Q	1	1	1	1	1	1
120	0	0	0	0	0	0
OE	1	1	1	1	1	1
HS1	1	1	1	0	0	0
HS2	1	1	0	0	0	1
HS3	1	0	0	0	1	1
OUT1	T	+	+	T	0	0
OUT2	-	-	T	+	+	T
OUT3	+	T	0	0	T	+

BC05 • BC05A

GENERAL

Much useful application information for these products can be obtained from Application Notes 1 (General Operating Considerations) and 30 (PWM Basics).

PWM CONSIDERATIONS

The BC05 can be configured with a logic-input (2Q) to operate either as a 2-quadrant or 4-quadrant controller. 2-quadrant PWM holds one coil terminal at a constant level and applies PWM at the other. PWM is applied at the positive terminal when in 2-quadrant mode. 4-quadrant PWM switches both terminals. 2-quadrant PWM is electrically slightly quieter and slightly more efficient, but cannot transition through zero. Therefore 4-quadrant PWM is required for applications such as position servos, phase locked motor control, or accurately following complex velocity profiles. 2-quadrant PWM is preferable for unidirectional speed control applications. The R input may be used to reverse the motor when using 2-quadrant PWM, but must be at logic "0" when in 4-quadrant mode.

COMMUTATION

The BC05 may be configured to operate with either 60° or 120° Hall sensor patterns by the state of the 120 input. (Obviously also with encoder outputs having the same logic.) When 120 is low the BC05 operates with 60° commutation; when 120 is high they operate with 120° commutation.

The relationship between commutation states and motor drive output is tabulated in the following tables [See Tables 1-4 on previous page]. For the purposes of these tables PWM that is mostly positive will be designated +; PWM that is mostly low will be designated -; a constant low state will be designated by 0; a tri-state condition will be designated T; REF IN is more positive than FB; and "Forward" rotation is the only direction tabulated. Position is given in electrical degrees.

Some motor manufacturers may not use the same conventions in identifying motor and Hall sense leads as Apex. In that event you may have to experimentally identify the corresponding motor and Hall Sense leads. For 3 binary square waves with equal phase shifts between the square waves, such as Hall sense outputs, there are only 8 possible states. 60° commutation fills 6 of the states and 120° commutation fills the other set of 6 states. Therefore all such patterns are truly only 60° or 120°. Changing pattern is done in the Apex controller by inverting HS2 internally.

Once the proper commutation patterns are obtained it is necessary to determine the motor lead orientation to the Hall sense. This may be done by turning the motor with a test fixture and observing the relationship between the HS patterns and the EMF, or by running the motor at low voltage and systematically switching motor leads until smooth running in the desired direction is obtained. The motor can be expected to run smoothly in the desired direction, run reverse, not run at all, or vibrate violently between 2 positions as this is done.

PROTECTION CIRCUITS

There are four protection circuits in the BC05.

1. The peak current sensing circuit, which is programmed by the value of the current sense resistors placed by the user between the DMOS sources and HV return. This circuit is reset each PWM cycle. If three current sense resistors are used, as recommended, an analog multiplexer selects the current sense resistor, which has the same current as the motor coil. This technique blanks out noise and provides an excellent sensing of actual coil current. The programming of this circuit is accomplished by the following formula:

$$I_{TRIP} = 0.5/R_{SENSE}$$

Note that for large currents R_{SENSE} becomes very small, therefore stray resistance in the high current path can have a large effect. Heavy etch should be used in the current sensing path, and leads should be very short between the resistors and the pins of the controller.

2. Thermal Protection
The junction temperature of all power devices is sensed, and the controller is shut down when too hot. This circuit is a latch and can be reset when OE is turned on, providing the power devices have cooled to a safe temperature.
3. There is an over-current circuit which shut down the BC05 when the current provided by the HV supply exceeds about 1.5 times the peak current rating. This circuit latches and may be reset by cycling the OE input. Although this is "top rail" protection, a short to ground will probably destroy the BC05.
4. The output circuit will shut down if a power supply is missing. This is not an alarmed fault.

FAULT

The FAULT output is an alarm, a logic 1 indicates the outputs are disabled. Fault is at 1 when OE is at 0, and it is at logic 0 when OE is at 1 during normal operation. Outputs will latch to the disabled state and fault will be at logic 1 when any IGBT is too hot or when peak IGBT current has exceeded a safe level for the IGBT. This may be reset by setting OE to logic 0 and back to logic 1.

When the coil sensing circuit senses that the average current has exceeded the level set by the selection of current sense resistors, the output will be disabled and the FAULT output will go to logic 1. (Even though the output has been disabled coil current will continue, flowing through the diodes in anti-parallel with each IGBT.) When coil current has decayed to below this set level the outputs will be enabled and FAULT will be at logic 0. Thus when limiting the average value of coil current the output will cycle between being disabled and enabled, and FAULT will cycle between logic 1 and 0. This action may cause an audible hiss when driving low inertia systems.

OPEN LOOP OPERATION

The normal way of operating the controller open loop is connect the input, REF IN pin 24 to a reference, and the FB input, pin 24 to an analog voltage. When this is done in conjunction with 2-quadrant PWM the voltage applied to the motor coils will be:

$$V_M = 25(HV)(V_{IN} - V_{REF}) + HV/2$$

Where:

HV is the motor supply.

V_{IN} is the input voltage.

V_{REF} is the analog reference.

If 4-quadrant PWM is used the equation becomes:

$$V_M = 50(HV)(V_{IN} - V_{REF})$$

The input dynamic range can be as small as 36mV for both 2-quadrant or 4-quadrant PWM (No larger than 40mV). The dynamic range can be extended, with the penalty of gain loss, by putting matched resistors in series with the FB and REF IN inputs. The value of these resistors for a given dynamic range is given by the following equation:

$$R_{IN} = (V_{INMAX}/0.036) - 1$$

Where:

V_{INMAX} is the desired p-p input.

R_{IN} is the required minimum value for the resistors to be put in series with the FB and REF IN inputs, in kilo-ohms.

When these resistors are used gain is reduced. The new motor voltage equation for 2-quadrant operation is:

$$V_M = HV/2 + (25(HV)(V_{IN} - V_{REF}))/R_{IN} + 1$$

The new equation for 4-quadrant operation is:

$$V_M = (50(HV)(V_{IN} - V_{REF}))/R_{IN} + 1$$

An alternative mode of open loop operation is to leave the FB and REF IN inputs open, and connect the input to the TORQUE input, either directly or through a series resistor. When this is done the input signal is effectively referenced to an internal 5.00V supply, V_{DD} (This supply is not brought to a pin). Just as when using the REF IN and FB inputs, dynamic range can be increased (and gain decreased) by use of a series resistor, but only one is required. For 2-quadrant operation the equation for motor voltage is:

$$V_M = HV/2 + (25(HV)(V_{DD} - V_{IN}))/R_{IN} + 10$$

For 4-quadrant operation the equation for motor voltage is:

$$V_M = (50(HV)(V_{DD} - V_{IN}))/R_{IN} + 10$$

R_{IN} can be determined for a linear dynamic range for both 2-quadrant and 4-quadrant PWM from the following equation:

$$R_{IN} = (V_{INMAX}/0.036) - 10$$

OPERATION WITH NEGATIVE ANALOG INPUTS

The REF IN and FB inputs are inputs to a true differential

amplifier. These inputs operate over a range between signal ground and +10V. However, with the addition 2 resistors, a diode, and loss of gain the circuit will operate with input voltages below ground. To operate with these inputs going to -10V the gain loss is 26.5 dB. When used with an external controller, which can compensate for this lost gain, this is insignificant.

To choose a resistor to hold the input to the internal amplifier within its range, use the following formula:

$$R_{IN} = 2.06(4.9 + V_{IN}) - 11.09$$

Where:

R_{IN} is the minimum value of the external resistor in K-ohms.

V_{IN} is the absolute value of the most negative input level.

A resistor of this value should be inserted in series with both the REF IN and FB inputs. Since unbalance in these resistors affects dc offset and common mode rejection, precision resistors should be used. If the host system can produce steps to the REF IN input with less than 11 μ -seconds transients below ground on the internal amplifier will occur. Connecting a diode with its cathode tied to pin 23, REF IN, and its anode to ground will clamp these to a safe level.

EXAMPLE: Assume an input voltage of -10V. The formula gives a minimum input resistance of 19.6K. The lowest 1% value above 19.6K is 20.0K. A nominal 20.0K resistor 2% low is 19.6K, so a 20.0K resistor whose variation to all effects is 2% is safe..

CLOSED LOOP OPERATION

The controller may be operated in a closed loop by applying the command signal to the REF IN input, pin 23, and analog feedback to FB, pin 24. Or, if operating with resistors in series with pins 23 and 24, through those resistor to pins 23 and 24. In this case the gain as a servo amplifier is given by the equation of sections 2 or 3 of the "Open Loop Operation" section.

TRANSCONDUCTANCE AMPLIFIER OPERATION

The BC05 can be operated in a transconductance amplifier mode by connecting the MOTOR I output to the TORQUE input either directly or through a resistor.

It is convenient to chose the current sense resistors for the desired average current limit first, as described in section 1 of the protection circuits section, and then choose the current feedback resistor for the desired transconductance. If 2 quadrant PWM is being used the equation for calculating transconductance is:

$$G_M = 2.5(A)(V)(R_{FBI} + 10K)/(R_L(R_{FBI} + 10K) + 125000(V)(R_S))$$

Where:

A is the gain of the Input Amp.

$A = 10K/(1K + R_{IN})$

G_M is the overall transconductance.

V is the motor supply voltage.

R_L is the load resistance (terminal to terminal armature resistance for the motor plus any added resistance.)

R_S is the sense resistance.

BC05 • BC05A

OPERATING CONSIDERATIONS

R_{FBI} is the resistor from MOTOR I to TORQUE.
 R_{IN} is the value of the external resistors used to reduce gain.

Solving this equation for R_{FBI} :

$$R_{FBI} = 125000(G_M)(V)(R_S) / (2.5(A)(V) - G_M(R_L)) - 10K$$

If $125000(V)(R_S)$ is large compared to $R_L(R_{FBI} + 10K)$, not always the case, then the equations simplify to:

$$G_M = A(R_{FBI} + 10K) / (50000R_S)$$

$$R_{FBI} = 50000(R_S)(G_M) / A - 10K$$

However the voltage gain of the PWM amplifier is twice as high when a 4 quadrant PWM is used. In this case:

$$G_M = 5(A)(V)(R_{FBI} + 10K) / (R_L(R_{FBI} + 10K) + 250000(V)(R_S))$$

Solving this equation for R_{FBI} :

$$R_{FBI} = 250000(G_M)(V)(R_S) / (5(A)(V) - G_M(R_L)) - 10K$$

If $250000(V)(R_S)$ is large compared to $R_L(R_{FBI} + 10K)$, not always the case, then the equations simplify to the same as in the 2 quadrant case:

$$G_M = A(R_{FBI} + 10K) / (50000R_S)$$

$$R_{FBI} = (50000(R_S)(G_M) / A) - 10K$$

GROUNDING AND BYPASSING

The BC05 output switches hundreds of volts and tens of amperes with nano-second rise and fall times. Thus care in bypassing and grounding is required to eliminate noise in the system..

High voltage return and signal ground are electrically isolated in the BC05. This allows connections which avoid ground loops. However in order to avoid damaging offsets between grounds on internal components internal back schottky diodes are installed between signal ground and high voltage return. So, at a minimum, signal ground and high voltage must be tied together at one point in the system. Clean operation has been obtained with single point grounding, grounds tied together at the BC05, and with the combination of single point grounding for dc with grounds ac connected at the BC05 with a 1 μ f capacitor. The system designer should follow best practice for his system.

On the high voltage supply a switching regulator grade electrolytic capacitor should be installed between high voltage and high voltage return. This capacitor should be installed at the BC05, with leads as short as practical. Apex recommends 10 μ f per ampere of output current for this capacitor. The voltage rating should withstand the highest transient voltage on the high voltage supply; transients should not be allowed exceed 450V for safe operation of the BC05. This is required even if large value filter capacitors are in the high voltage supply.

A 1 μ f minimum ceramic capacitor with the same voltage rating as the electrolytic should also be installed across the high voltage supply. This capacitor should be installed directly from the high voltage pin to the high voltage return pin. (In our test set ups, this capacitor has a total lead length

of less than 2 inches.)

The control circuit power supply, V_{CC} is internally bypassed with a 0.1 μ f ceramic. There is no additional bypassing in Apex test set ups, although it certainly wouldn't be harmful.

APPLICATION REFERENCES

For additional technical information please refer to the following Application Notes:

- AN 1: General Operating Considerations
- AN 30: PWM Basics

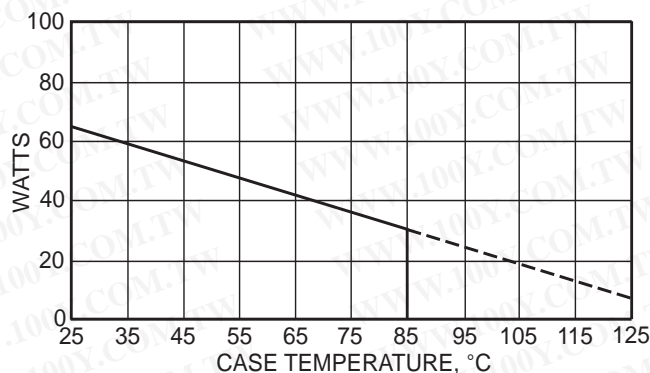

Figure 2: Power Derating, Each Active FET