



AME, Inc.

勝特力材料 886-3-5753170
勝特力电子(上海) 86-21-54151736
勝特力电子(深圳) 86-755-83298787
Http://www.100y.com.tw

AME1085

3A Low Dropout Positive Voltage Regulator

General Description

The AME1085 is a 3A low-dropout positive voltage regulator. It is available in fixed and adjustable output voltage versions. Overcurrent and thermal protection are integrated onto the chip. Output current will limit as it reaches the pre-set current or temperature limit. At full rated output current the dropout voltage is 1.4V (max.). AME1085 series regulators provide excellent regulation over line, load and temperature variations.

Features

- Low dropout voltage 1.2V typically at 3A
- Adjustable or 3.3V fixed voltage
- Line regulation typically 0.015%
- Load regulation typically 0.05%
- Adjust pin (ADJ) current less than 90 μ A
- Overcurrent protection
- Thermal protection
- Available in TO-263, TO-252, TO-220

Applications

- High Efficiency Linear Regulators
- Post Regulators for Switching Supplies
- 5V to 3.3V Voltage Converter
- Battery Charger

Functional Block Diagram

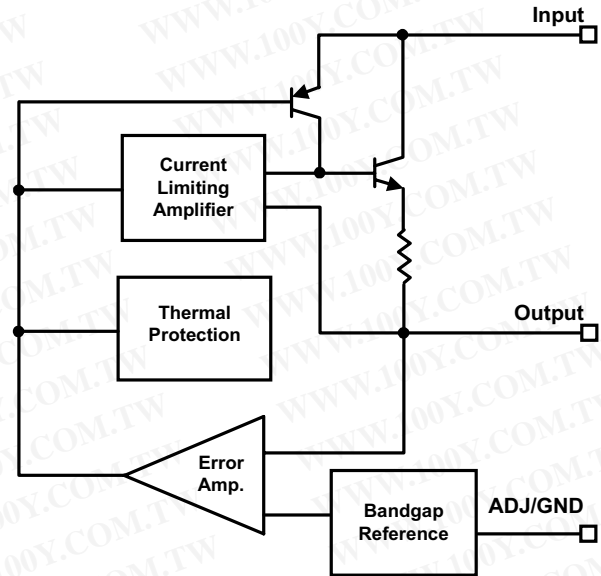

Typical Application

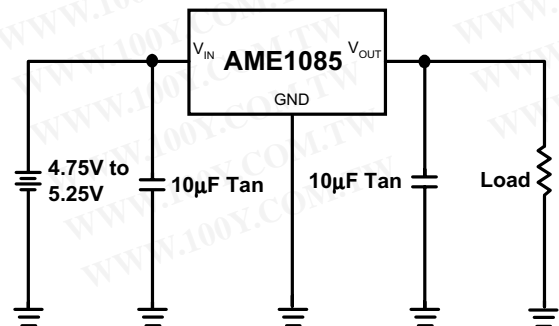

AME1085

**3A Low Dropout
Positive Voltage Regulator**

■ **Pin Configuration**

**TO-263-3
Front View**

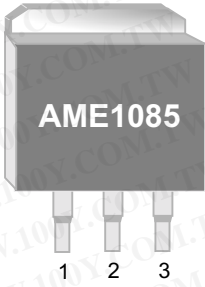

- AME1085**
1. ADJ / GND
 2. V_{OUT}
 3. V_{IN}

**TO-263-2
Front View**

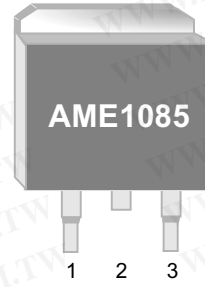

- AME1085**
1. ADJ / GND
 2. V_{OUT}
 3. V_{IN}

**TO-252-2
Front View**

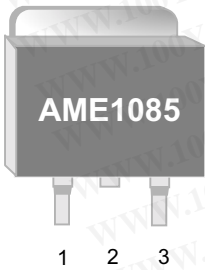

- AME1085**
1. ADJ / GND
 2. V_{OUT}
 3. V_{IN}

**TO-252-2
Front View**

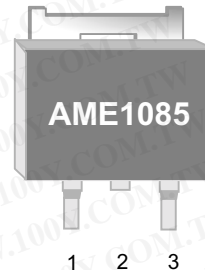

- AME1085**
1. ADJ / GND
 2. V_{OUT}
 3. V_{IN}

**TO-220
Front View**

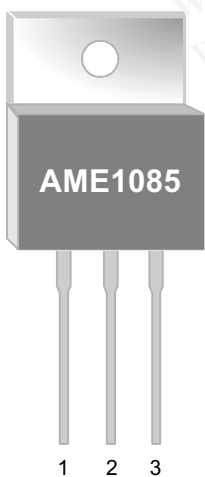

- AME1085**
1. ADJ / GND
 2. V_{OUT}
 3. V_{IN}



勝特力材料 886-3-5753170
勝特力电子(上海) 86-21-54151736
勝特力电子(深圳) 86-755-83298787
[Http://www.100y.com.tw](http://www.100y.com.tw)

AME1085

3A Low Dropout Positive Voltage Regulator

■ Ordering Information

Part Number	Marking	Output Voltage	Package	Operating Temp. Range
AME1085ACBT	AME1085 ACBT yyww	ADJ	TO-220	0°C to 70°C
AME1085DCBT	AME1085 DCBT yyww	3.3	TO-220	0°C to 70°C
AME1085ACDT-3	AME1085 ACDT-3 yyww	ADJ	TO-263-3	0°C to 70°C
AME1085DCDT-3	AME1085 DCDT-3 yyww	3.3	TO-263-3	0°C to 70°C
AME1085ACDT	AME1085 ACDT yyww	ADJ	TO-263-2	0°C to 70°C
AME1085DCDT	AME1085 DCDT yyww	3.3	TO-263-2	0°C to 70°C
AME1085AMCT	AME1085 AMCT yyww	ADJ	TO-252-2	0°C to 70°C
AME1085MCT*	AME1085 MCT yyww	3.3	TO-252-2	0°C to 70°C

* This differs from our standard part numbering scheme due to historical precedent.

Please consult AME sales office or authorized Rep./Distributor for other voltage accuracy and package type availability.



AME, Inc.

勝特力材料 886-3-5753170
 勝特力电子(上海) 86-21-54151736
 勝特力电子(深圳) 86-755-83298787
[Http://www.100y.com.tw](http://www.100y.com.tw)

AME1085

3A Low Dropout
Positive Voltage Regulator

■ Absolute Maximum Ratings

Parameter		Symbol	Maximum	Unit
Input Voltage		V_{IN}	7	V
Thermal Resistance (Junction to Case)	TO-220	θ_{JC}	2.5	°C/W
	TO-263		2.5	
	TO-252		15	
Thermal Resistance (Junction to Ambient)	TO-220	θ_{JA}	50	°C
	TO-263		60	
	TO-252		90	
Operating Junction Temperature Range		T_J	0 to 125	°C
Storage Temperature Range		T_{STG}	- 65 to 150	
Lead Temperature (10 Sec)		T_{LEAD}	260	

Caution: Stress above the listed absolute maximum rating may cause permanent damage to the device

AME1085

■ Electrical Specifications

AME1085Axxx

Parameter	Symbol	Test Condition		Min	Typ	Max	Units
Reference voltage (adjustable voltage)	V_{REF}	$V_{IN} = 5V$ $I_O = 10mA$	$T_J = 25^{\circ}C$	1.238	1.250	1.262	V
			Over temp.	1.225		1.275	
Line regulation	Reg_{LINE}	$V_{IN} = 2.75 - 7V$ $I_O = 10mA$	$T_J = 25^{\circ}C$	-	0.015	0.2	%
			Over temp.	-	0.035	0.2	
Load regulation	Reg_{LOAD}	$V_{IN} = 5V$ $I_O = 10mA - 3A$	$T_J = 25^{\circ}C$	-	0.05	0.3	%
			Over temp.	-	0.2	0.4	
Dropout voltage $\Delta V_{OUT}, \Delta V_{REF} = 1\%$	V_D	$I_O = 10mA - 3A$	$T_J = 25^{\circ}C$	-	1.2	1.4	V
			Over temp.	-	1.3	-	
Current limit	I_S	$V_{IN} = 2.75 - 7V$, Over temp.		3.0	-	-	A
Temperature Coefficient	T_C	$V_{IN} = 2.75 - 7V$, $I_O = 10mA - 3A$		-	0.005	-	%/ $^{\circ}C$
Temperature stability	T_S	$V_{IN} = 5V$, $I_O = 500mA$, Over temp.		-	0.5	-	%
Minimum load current	I_O	$V_{IN} = 5V$		10	-	-	mA
RMS output noise	V_N	$T_J = 25^{\circ}C$		-	0.003	-	% V_O
Ripple rejection ratio	R_A	$V_{IN} = 5V$, $I_O = 3A$, Over temp.		-	72	-	dB

AME1085Dxxx

Parameter	Symbol	Test Condition		Min	Typ	Max	Units
Output voltage (fixed voltage)	V_O	$V_{IN} = 5V$ $I_O = 0A$	$T_J = 25^{\circ}C$	3.267	3.300	3.333	V
			Over temp.	3.234		3.366	
Line regulation	Reg_{LINE}	$V_{IN} = 4.5 - 7V$ $I_O = 0A$	$T_J = 25^{\circ}C$	-	0.015	0.2	%
			Over temp.	-	0.035	0.2	
Load regulation	Reg_{LOAD}	$V_{IN} = 5V$ $I_O = 0A - 3A$	$T_J = 25^{\circ}C$	-	0.05	0.3	%
			Over temp.	-	0.2	0.4	
Dropout voltage $\Delta V_{OUT}, \Delta V_{REF} = 1\%$	V_D	$V_{IN} = 4.5 - 7V$ $I_O = 0A - 3A$	$T_J = 25^{\circ}C$	-	1.2	1.4	V
			Over temp.	-	1.3	-	
Current limit	I_S	$V_{IN} = 4.5 - 7V$, Over temp.		3.0	-	-	A
Quiescent current (fixed model)	I_Q	$V_{IN} = 5V$, $I_O = 0A - 3A$, Over temp.		-	12	13	mA
Temperature Coefficient	T_C	$V_{IN} = 4.5 - 7V$, $I_O = 0A - 3A$		-	0.005	-	%/ $^{\circ}C$
Temperature stability	T_S	$V_{IN} = 5V$, $I_O = 500mA$, Over temp.		-	0.5	-	%
RMS output noise	V_N	$T_J = 25^{\circ}C$		-	0.003	-	% V_O
Ripple rejection ratio	R_A	$V_{IN} = 5V$, $I_O = 3A$, Over temp.		60	72	-	dB

AME1085

■ Application Description

1. Output voltage adjustment

Like most regulators, the AME1085 regulates the output by comparing the output voltage to an internally generated reference voltage. On the adjustable version, the V_{REF} is available externally as 1.25V between V_{OUT} and ADJ. The voltage ratio formed by R1 and R2 should be set to conduct 10mA (minimum output load). The output voltage is given by the following equation:

$$V_{OUT} = V_{REF} \left(1 + \frac{R2}{R1} \right) + I_{ADJ} \times R2$$

On fixed versions of AME1085, the voltage divider is provided internally.

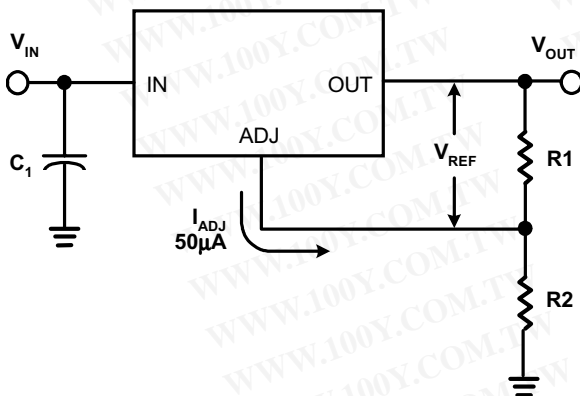

$$V_{OUT} = V_{REF} \left(1 + \frac{R2}{R1} \right) + I_{ADJ} \times R2$$

2. Thermal protection

AME1085 has thermal protection which limits junction temperature to 150°C. However, device functionality is only guaranteed to a maximum junction temperature of +125°C.

The power dissipation and junction temperature for AME1085 in TO-220 package are given by

$$P_D = (V_{IN} - V_{OUT}) \times I_{OUT}$$

$$T_{JUNCTION} = T_{AMBIENT} + (P_D \times \theta_{JA})$$

Note: $T_{JUNCTION}$ must not exceed 125°C

3. Current limit protection

AME1085 is protected against overload conditions. Current protection is triggered at typical 4.5A.

4. Stability and load regulation

AME1085 requires a capacitor from V_{OUT} to GND to provide compensation feedback to the internal gain stage. This is to ensure stability at the output terminal. Typically, a 10µF tantalum or 50µF aluminum electrolytic is sufficient.

(Note: It is important that the ESR for this capacitor does not exceed 0.5Ω.)

The output capacitor does not have a theoretical upper limit and increasing its value will increase stability. $C_{OUT} = 100\mu\text{F}$ or more is typical for high current regulator design.

For the adjustable version, the best load regulation is accomplished when the top of the resistor divider (R1) is connected directly to the output pin of the AME1085. When so connected, R_p is not multiplied by the divider ratio. For fixed output versions, the top of R1 is internally connected to the output and ground pin can be connected to low side of the load.

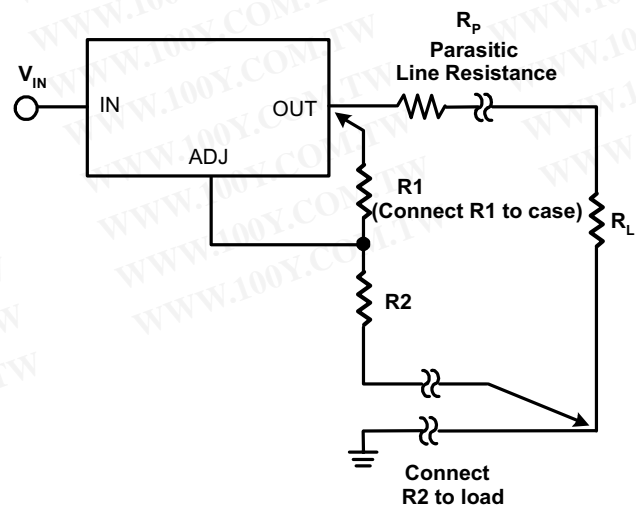



AME, Inc.

勝特力材料 886-3-5753170
勝特力电子(上海) 86-21-54151736
勝特力电子(深圳) 86-755-83298787
[Http://www.100y.com.tw](http://www.100y.com.tw)

AME1085

3A Low Dropout Positive Voltage Regulator

5. Thermal consideration

The AME1085 series contain thermal limiting circuitry designed to protect itself for over-temperature conditions. Even for normal load conditions, maximum junction temperature ratings must not be exceeded. As mention in thermal protection section, we need to consider all sources of thermal resistance between junction and ambient. It includes junction-to-case, case-to-heat-sink interface and heat sink thermal resistance itself.

Junction-to-case thermal resistance is specified from the IC junction to the bottom of the case directly below the die. Proper mounting is required to ensure the best possible thermal flow from this area of the package to the heat sink. The case of all devices in this series is electrically connected to the output. Therefore, if the case of the device must be electrically isolated, a thermally conductive spacer is recommended.

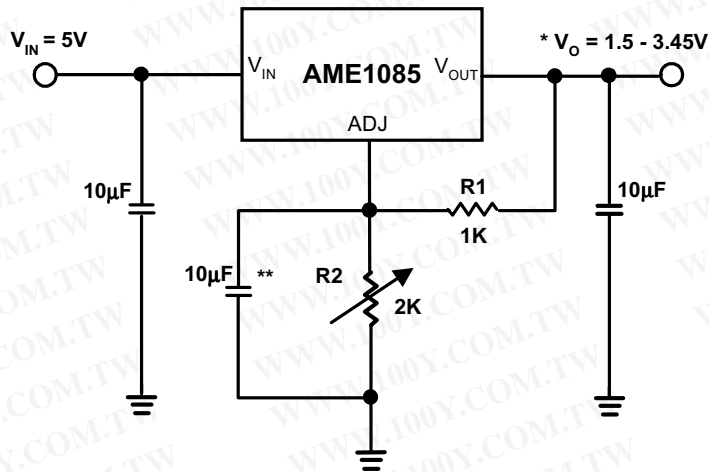
AME1085
■ Advanced Applications
Adjustable Output Voltage

Note: $* V_{OUT} = V_{REF} \left(1 + \frac{R2}{R1} \right) + I_{ADJ} \times R2$

** Optional for improved ripple rejection

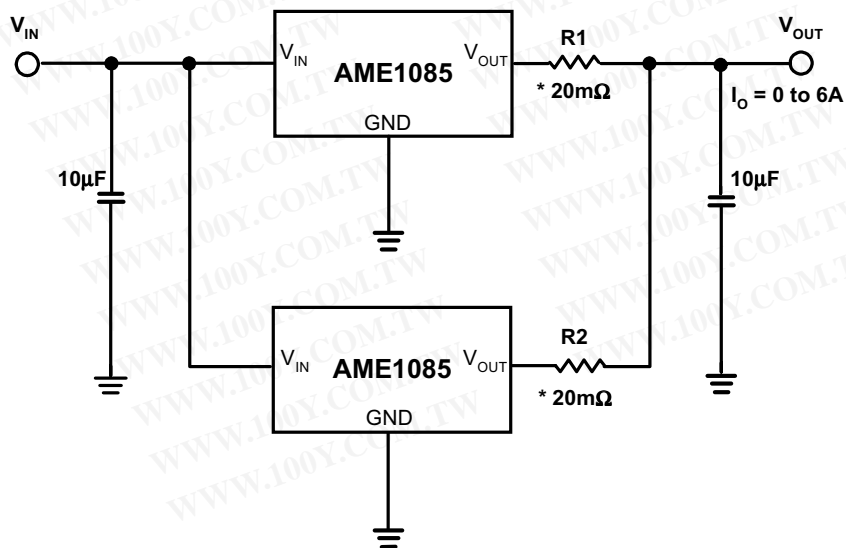
Paralleling Regulators

Note: * 20mΩ is ballast resistance
The inter - connection of #18 wire could act as ballast resistance

■ Advanced Applications (contd.)

Regulator with Reference

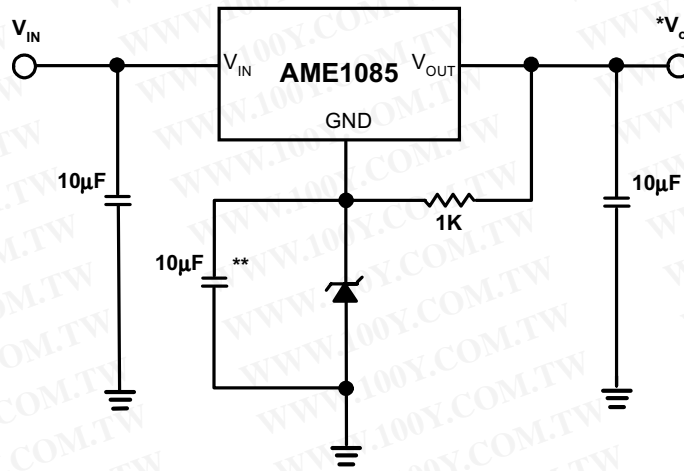

Note: * $V_o = V_{REF} + V_Z$ (V_Z : breakdown voltage of Zener diode)
 ** Optional for improved ripple rejection

Regulator with Reverse Diode Protection

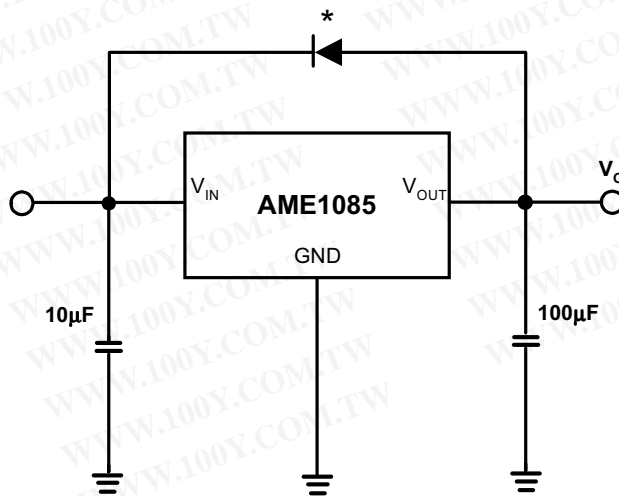

AME1085

■ External Resistor Divider Table for Customized Voltage

R1 (Ohm)	100	102	105	107	110	113	115	118	121	124
Vout	R2(Ohm)=(Vout-1.25)*R1/(1.25+50u*R1)									
1.25	0.000	0.000	0.000	0.000	0.000	0.000	0.000	0.000	0.000	0.000
1.30	3.984	4.063	4.182	4.262	4.381	4.500	4.579	4.698	4.817	4.936
1.35	7.968	8.127	8.365	8.524	8.761	8.999	9.158	9.396	9.633	9.871
1.40	11.95	12.19	12.55	12.79	13.14	13.50	13.74	14.09	14.45	14.81
1.45	15.94	16.25	16.73	17.05	17.52	18.00	18.32	18.79	19.27	19.74
1.50	19.92	20.32	20.91	21.31	21.90	22.50	22.89	23.49	24.08	24.68
1.55	23.90	24.38	25.09	25.57	26.28	27.00	27.47	28.19	28.90	29.61
1.60	27.89	28.44	29.28	29.83	30.67	31.50	32.05	32.88	33.72	34.55
1.65	31.87	32.51	33.46	34.09	35.05	36.00	36.63	37.58	38.53	39.48
1.70	35.86	36.57	37.64	38.36	39.43	40.50	41.21	42.28	43.35	44.42
1.75	39.84	40.63	41.82	42.62	43.81	45.00	45.79	46.98	48.17	49.36
1.80	43.82	44.70	46.01	46.88	48.19	49.50	50.37	51.68	52.98	54.29
1.85	47.81	48.76	50.19	51.14	52.57	54.00	54.95	56.37	57.80	59.23
1.90	51.79	52.82	54.37	55.40	56.95	58.50	59.53	61.07	62.62	64.16
1.95	55.78	56.89	58.55	59.66	61.33	63.00	64.11	65.77	67.43	69.10
2.00	59.76	60.95	62.74	63.93	65.71	67.49	68.68	70.47	72.25	74.03
2.05	63.75	65.01	66.92	68.19	70.09	71.99	73.26	75.17	77.07	78.97
2.10	67.73	69.08	71.10	72.45	74.47	76.49	77.84	79.86	81.88	83.90
2.15	71.71	73.14	75.28	76.71	78.85	80.99	82.42	84.56	86.70	88.84
2.20	75.70	77.21	79.47	80.97	83.23	85.49	87.00	89.26	91.52	93.77
2.25	79.68	81.27	83.65	85.24	87.61	89.99	91.58	93.96	96.33	98.71
2.30	83.67	85.33	87.83	89.50	92.00	94.49	96.16	98.65	101.2	103.6
2.35	87.65	89.40	92.01	93.76	96.38	98.99	100.7	103.4	106.0	108.6
2.40	91.63	93.46	96.20	98.02	100.8	103.5	105.3	108.1	110.8	113.5
2.45	95.62	97.52	100.4	102.3	105.1	108.0	109.9	112.7	115.6	118.5
2.50	99.60	101.6	104.6	106.5	109.5	112.5	114.5	117.4	120.4	123.4
2.55	103.6	105.6	108.7	110.8	113.9	117.0	119.1	122.1	125.2	128.3
2.60	107.6	109.7	112.9	115.1	118.3	121.5	123.6	126.8	130.1	133.3
2.65	111.6	113.8	117.1	119.3	122.7	126.0	128.2	131.5	134.9	138.2
2.70	115.5	117.8	121.3	123.6	127.0	130.5	132.8	136.2	139.7	143.1
2.75	119.5	121.9	125.5	127.9	131.4	135.0	137.4	140.9	144.5	148.1
2.80	123.5	126.0	129.7	132.1	135.8	139.5	141.9	145.6	149.3	153.0
2.85	127.5	130.0	133.8	136.4	140.2	144.0	146.5	150.3	154.1	157.9
2.90	131.5	134.1	138.0	140.6	144.6	148.5	151.1	155.0	159.0	162.9
2.95	135.5	138.2	142.2	144.9	148.9	153.0	155.7	159.7	163.8	167.8
3.00	139.4	142.2	146.4	149.2	153.3	157.5	160.3	164.4	168.6	172.7
3.05	143.4	146.3	150.6	153.4	157.7	162.0	164.8	169.1	173.4	177.7
3.10	147.4	150.3	154.8	157.7	162.1	166.5	169.4	173.8	178.2	182.6



勝特力材料 886-3-5753170
 勝特力电子(上海) 86-21-54151736
 勝特力电子(深圳) 86-755-83298787
[Http://www.100y.com.tw](http://www.100y.com.tw)

**3A Low Dropout
 Positive Voltage Regulator**

AME1085

External Resistor Divider Table for Customized Voltage (contd.)

R1 (Ohm)	100	102	105	107	110	113	115	118	121	124
Vout	R2(Ohm)=(Vout-1.25)*R1/(1.25+50u*R1)									
3.15	151.4	154.4	158.9	161.9	166.5	171.0	174.0	178.5	183.0	187.5
3.20	155.4	158.5	163.1	166.2	170.8	175.5	178.6	183.2	187.9	192.5
3.25	159.4	162.5	167.3	170.5	175.2	180.0	183.2	187.9	192.7	197.4
3.30	163.3	166.6	171.5	174.7	179.6	184.5	187.7	192.6	197.5	202.4
3.35	167.3	170.7	175.7	179.0	184.0	189.0	192.3	197.3	202.3	207.3
3.40	171.3	174.7	179.8	183.3	188.4	193.5	196.9	202.0	207.1	212.2
3.45	175.3	178.8	184.0	187.5	192.8	198.0	201.5	206.7	211.9	217.2
3.50	179.3	182.9	188.2	191.8	197.1	202.5	206.1	211.4	216.8	222.1
3.55	183.3	186.9	192.4	196.0	201.5	207.0	210.6	216.1	221.6	227.0
3.60	187.3	191.0	196.6	200.3	205.9	211.5	215.2	220.8	226.4	232.0
3.65	191.2	195.0	200.8	204.6	210.3	216.0	219.8	225.5	231.2	236.9
3.70	195.2	199.1	204.9	208.8	214.7	220.5	224.4	230.2	236.0	241.8
3.75	199.2	203.2	209.1	213.1	219.0	225.0	228.9	234.9	240.8	246.8
3.80	203.2	207.2	213.3	217.3	223.4	229.5	233.5	239.6	245.7	251.7
3.85	207.2	211.3	217.5	221.6	227.8	234.0	238.1	244.3	250.5	256.6
3.90	211.2	215.4	221.7	225.9	232.2	238.5	242.7	249.0	255.3	261.6
3.95	215.1	219.4	225.9	230.1	236.6	243.0	247.3	253.7	260.1	266.5
4.00	219.1	223.5	230.0	234.4	240.9	247.5	251.8	258.4	264.9	271.5
4.05	223.1	227.6	234.2	238.7	245.3	252.0	256.4	263.1	269.7	276.4
4.10	227.1	231.6	238.4	242.9	249.7	256.5	261.0	267.8	274.6	281.3
4.15	231.1	235.7	242.6	247.2	254.1	261.0	265.6	272.5	279.4	286.3
4.20	235.1	239.7	246.8	251.4	258.5	265.5	270.2	277.2	284.2	291.2
4.25	239.0	243.8	250.9	255.7	262.8	270.0	274.7	281.9	289.0	296.1
4.30	243.0	247.9	255.1	260.0	267.2	274.5	279.3	286.6	293.8	301.1
4.35	247.0	251.9	259.3	264.2	271.6	279.0	283.9	291.3	298.6	306.0
4.40	251.0	256.0	263.5	268.5	276.0	283.5	288.5	296.0	303.5	310.9
4.45	255.0	260.1	267.7	272.8	280.4	288.0	293.1	300.7	308.3	315.9
4.50	259.0	264.1	271.9	277.0	284.7	292.5	297.6	305.4	313.1	320.8
4.55	262.9	268.2	276.0	281.3	289.1	297.0	302.2	310.1	317.9	325.7
4.60	266.9	272.2	280.2	285.5	293.5	301.5	306.8	314.8	322.7	330.7
4.65	270.9	276.3	284.4	289.8	297.9	306.0	311.4	319.5	327.5	335.6
4.70	274.9	280.4	288.6	294.1	302.3	310.5	315.9	324.2	332.4	340.6
4.75	278.9	284.4	292.8	298.3	306.7	315.0	320.5	328.8	337.2	345.5
4.80	282.9	288.5	297.0	302.6	311.0	319.5	325.1	333.5	342.0	350.4
4.85	286.9	292.6	301.1	306.8	315.4	324.0	329.7	338.2	346.8	355.4
4.90	290.8	296.6	305.3	311.1	319.8	328.5	334.3	342.9	351.6	360.3
4.95	294.8	300.7	309.5	315.4	324.2	333.0	338.8	347.6	356.4	365.2
5.00	298.8	304.8	313.7	319.6	328.6	337.5	343.4	352.3	361.3	370.2

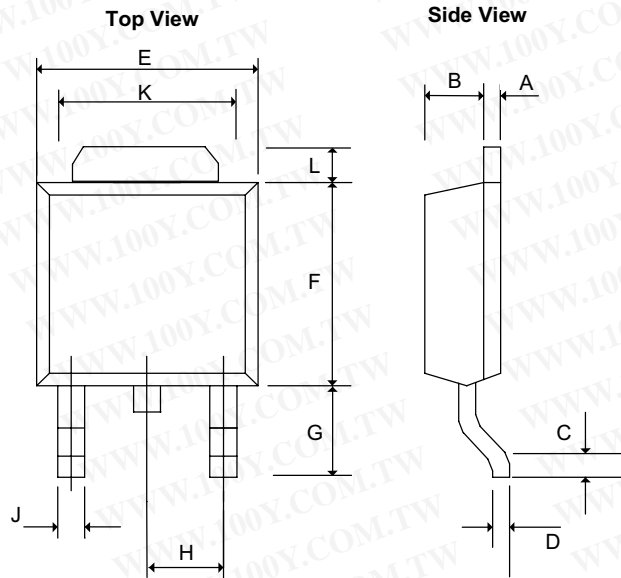
AME1085
■ Package Dimension
TO-252(DPAK)-EIAJ

SYMBOLS	MILLIMETERS		INCHES	
	MIN	MAX	MIN	MAX
A	0.45	0.58	0.0177	0.0230
B	1.60	1.95	0.0630	0.0768
C	0.51	1.50	0.0201	0.0591
D	0.45	0.60	0.0177	0.0236
E	6.40	6.80	0.2520	0.2677
F	5.40	7.20	0.2126	0.2835
G	2.20	2.85	0.0866	0.1122
H	-	* 2.30	-	* 0.0906
J	-	0.97	-	0.0380
K	5.20	5.50	0.2047	0.2165
L	1.40REF		0.055REF	

*: Typical Value

Notes:

- Controlling dimension: Millimeters.
- Maximum lead thickness includes lead finish thickness Minimum lead thickness is the minimum thickness of base material.

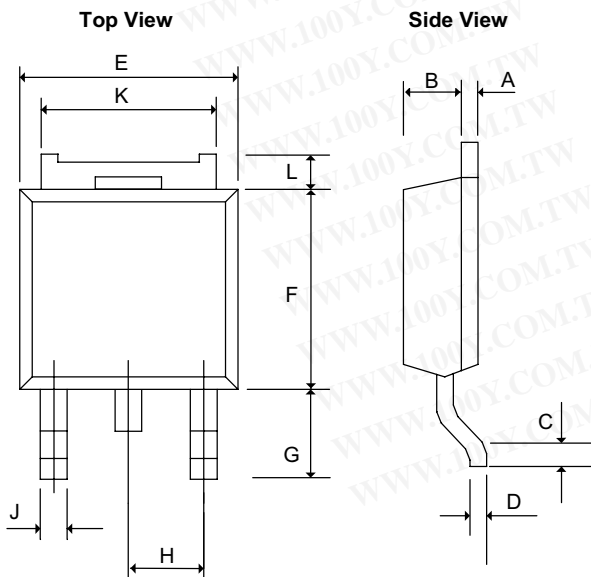
TO-252(DPAK)-JEDC

SYMBOLS	MILLIMETERS		INCHES	
	MIN	MAX	MIN	MAX
A	0.49	0.51	0.0192	0.0201
B	1.79	1.81	0.0704	0.0713
C	0.55	-	0.0216	-
D	0.49	0.51	0.0192	0.0201
E	6.58	6.62	0.259	0.2606
F	6.08	6.12	0.2393	0.2409
G	2.68	2.72	0.1055	0.1071
H	* 2.30REF		* 0.0906REF	
J	0.96		0.0377	
K	5.31	5.37	0.2090	0.2114
L	0.68	0.72	0.0267	0.0283

*: Typical Value

Notes:

- Controlling dimension: Millimeters.
- Maximum lead thickness includes lead finish thickness Minimum lead thickness is the minimum thickness of base material.



AME1085

3A Low Dropout Positive Voltage Regulator

Package Dimension

TO-263-2(D²PAK)

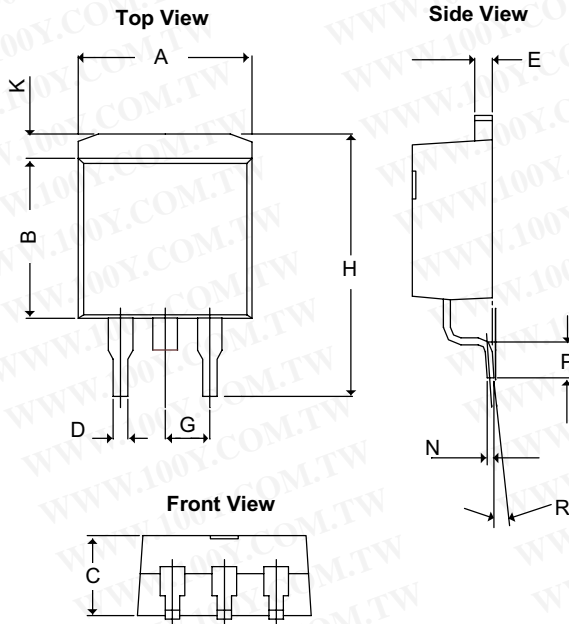

SYMBOLS	MILLIMETERS		INCHES	
	MIN	MAX	MIN	MAX
A	9.65	10.42	0.380	0.410
B	8.28	9.66	0.326	0.380
C	4.06	4.83	0.160	0.190
D	0.50	1.02	0.020	0.040
E	1.14	1.40	0.045	0.055
G	*2.54		*0.100	
H	14.60	15.60	0.5748	0.61417
K	0.99	2.93	0.03898	0.11535
N	0.381REF		0.015REF	
P	2.28	2.80	0.08976	0.11024
R	0°	8°	0°	8°

*: Typical Value

Notes:

1. Controlling dimension: Millimeters.
2. Maximum lead thickness includes lead finish thickness Minimum lead thickness is the minimum thickness of base material.

TO-263-3(D²PAK)

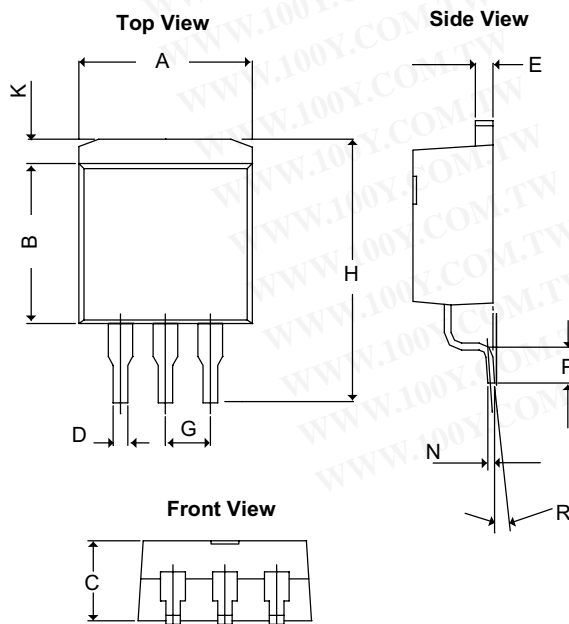

SYMBOLS	MILLIMETERS		INCHES	
	MIN	MAX	MIN	MAX
A	9.65	10.42	0.380	0.410
B	8.28	9.66	0.326	0.380
C	4.06	4.83	0.160	0.190
D	0.50	1.02	0.020	0.040
E	1.14	1.40	0.045	0.055
G	*2.54		*0.100	
H	14.60	15.60	0.5748	0.61417
K	0.99	2.93	0.03898	0.11535
N	0.381REF		0.015REF	
P	2.28	2.80	0.08976	0.11024
R	0°	8°	0°	8°

*: Typical Value

Notes:

1. Controlling dimension: Millimeters.
2. Maximum lead thickness includes lead finish thickness Minimum lead thickness is the minimum thickness of base material.

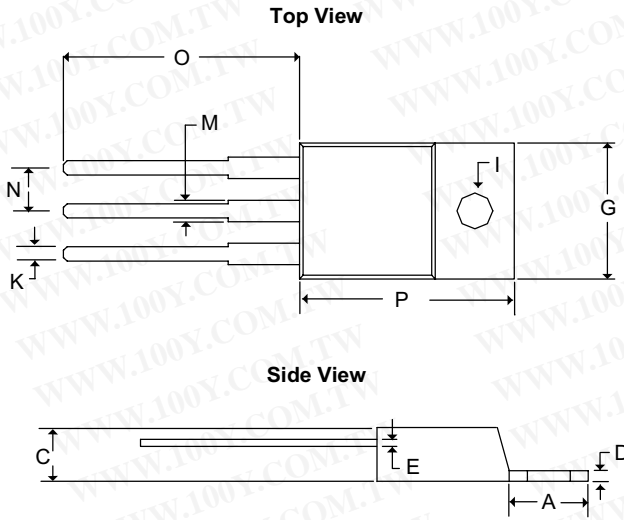
AME1085
**3A Low Dropout
Positive Voltage Regulator**
■ Package Dimension
TO-220

SYMBOLS	MILLIMETERS		INCHES	
	MIN	MAX	MIN	MAX
A	5.58	7.49	0.2197	0.2949
C	3.55	4.83	0.1398	0.1900
D	0.50	1.40	0.0197	0.0550
E	0.30	1.15	0.0118	0.0453
G	9.65	10.67	0.3799	0.4200
I	3.53	4.09	0.1390	0.1610
K	0.50	1.15	0.0197	0.0453
M	1.14	1.78	0.0449	0.0700
N	2.28	2.80	0.0898	0.1102
O	12.70	14.74	0.5000	0.5803
P	14.22	16.51	0.5600	0.6500