

- Meets or Exceeds the Requirements of ANSI TIA/EIA-422-B and ITU Recommendation V.11
- Operates From a Single 5-V Supply
- TTL Compatible
- Complementary Outputs
- High Output Impedance in Power-Off Conditions
- Complementary Output-Enable Inputs

**description/ordering information**

The AM26LS31 is a quadruple complementary-output line driver designed to meet the requirements of ANSI TIA/EIA-422-B and ITU (formerly CCITT) Recommendation V.11. The 3-state outputs have high-current capability for driving balanced lines such as twisted-pair or parallel-wire transmission lines, and they are in the high-impedance state in the power-off condition. The enable function is common to all four drivers and offers the choice of an active-high or active-low enable (G,  $\bar{G}$ ) input. Low-power Schottky circuitry reduces power consumption without sacrificing speed.

**D, DB, N, NS, OR J PACKAGE  
 (TOP VIEW)**

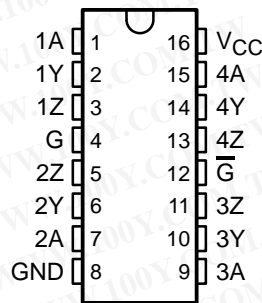

**FK PACKAGE  
 (TOP VIEW)**

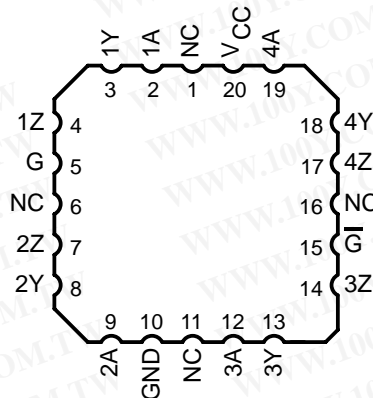

**ORDERING INFORMATION**

TA	PACKAGE†		ORDERABLE PART NUMBER	TOP-SIDE MARKING
0°C to 70°C	PDIP – N	Tube	AM26LS31CN	AM26LS31CN
	SOIC – D	Tube	AM26LS31CD	AM26LS31C
		Tape and reel	AM26LS31CDR	
	SOP – NS	Tape and reel	AM26LS31CNSR	26LS31
SSOP – DB	Tape and reel	AM26LS31CDBR	SA31C	
–55°C to 125°C	CDIP – J	Tube	AM26LS31MJ	AM26LS31MJB
	LCCC – FK	Tube	AM26LS31MFK	AM26LS31MFKB

† Package drawings, standard packing quantities, thermal data, symbolization, and PCB design guidelines are available at [www.ti.com/sc/package](http://www.ti.com/sc/package).



Please be aware that an important notice concerning availability, standard warranty, and use in critical applications of Texas Instruments semiconductor products and disclaimers thereto appears at the end of this data sheet.

PRODUCTION DATA information is current as of publication date. Products conform to specifications per the terms of Texas Instruments standard warranty. Production processing does not necessarily include testing of all parameters.



# AM26LS31C, AM26LS31M QUADRUPLE DIFFERENTIAL LINE DRIVER

勝特力材料 886-3-5753170  
 勝特力电子(上海) 86-21-54151736  
 勝特力电子(深圳) 86-755-83298787  
[Http://www.100y.com.tw](http://www.100y.com.tw)

SLLS114H – JANUARY 1979 – REVISED JULY 2002

FUNCTION TABLE  
(each driver)

INPUT A	ENABLES		OUTPUTS	
	G	$\bar{G}$	Y	Z
H	H	X	H	L
L	H	X	L	H
H	X	L	H	L
L	X	L	L	H
X	L	H	Z	Z

H = high level, L = low level, X = irrelevant,  
 Z = high impedance (off)

## logic diagram (positive logic)

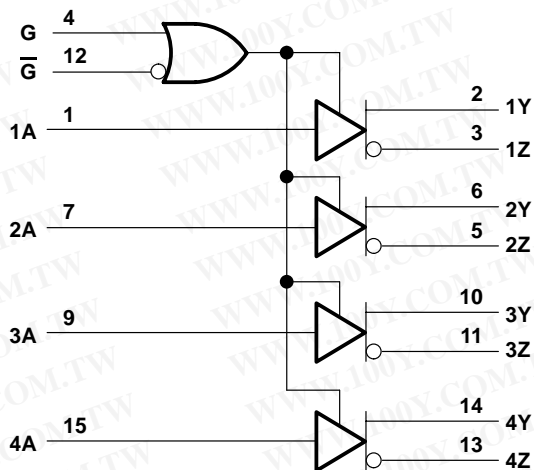

**schematic (each driver)**

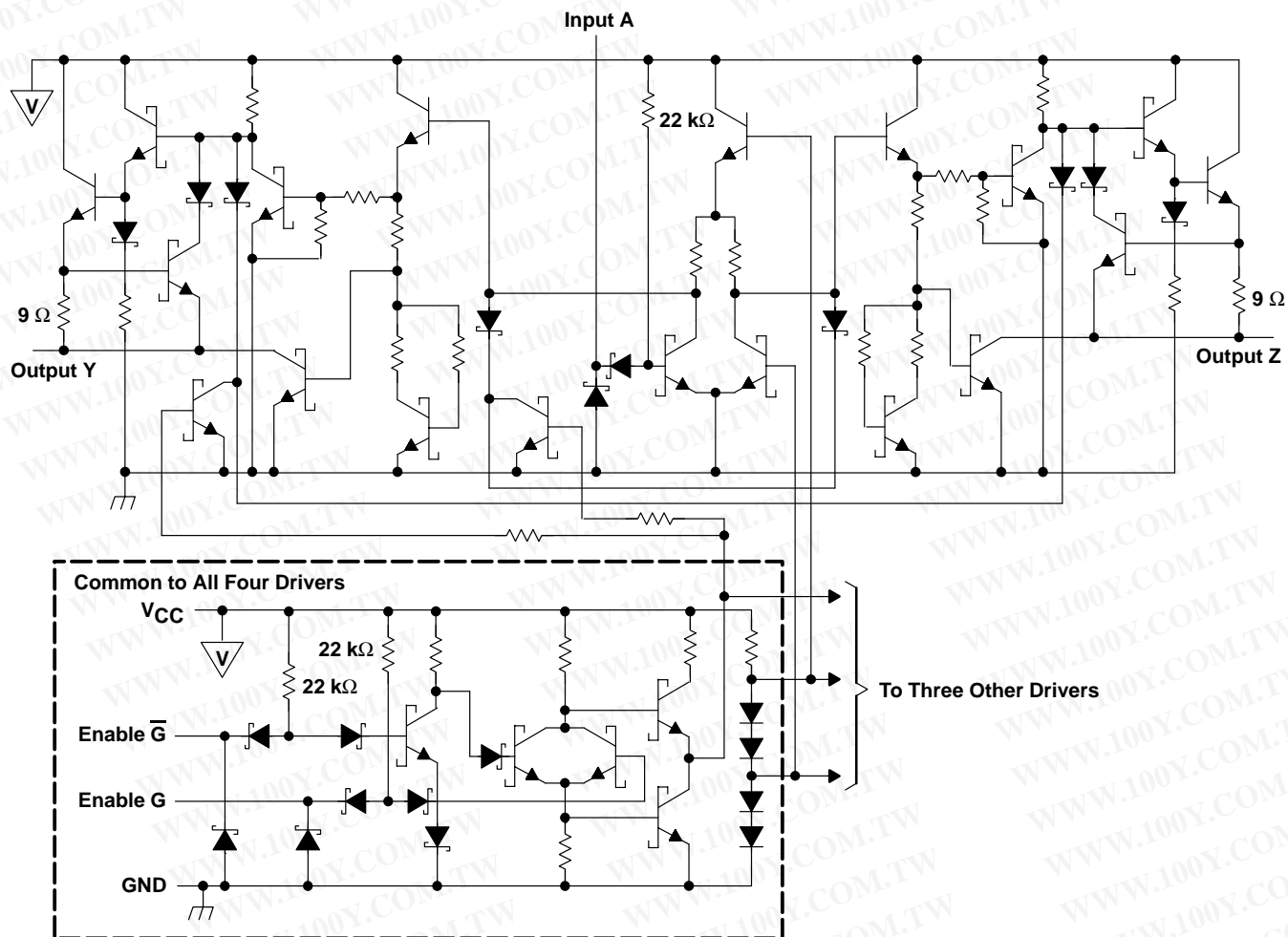

All resistor values are nominal.

# AM26LS31C, AM26LS31M QUADRUPLE DIFFERENTIAL LINE DRIVER

勝特力材料 886-3-5753170  
 勝特力电子(上海) 86-21-54151736  
 勝特力电子(深圳) 86-755-83298787  
[Http://www.100y.com.tw](http://www.100y.com.tw)

SLLS114H – JANUARY 1979 – REVISED JULY 2002

## absolute maximum ratings over operating free-air temperature range (unless otherwise noted)†

Supply voltage, $V_{CC}$ (see Note 1)	7 V
Input voltage, $V_I$	7 V
Output off-state voltage	5.5 V
Package thermal impedance, $\theta_{JA}$ (see Note 2):	
D package	73°C/W
DB package	82°C/W
N package	67°C/W
NS package	64°C/W
Lead temperature 1,6 mm (1/16 inch) from case for 10 seconds	260°C
Lead temperature 1,6 mm (1/16 inch) from case for 60 seconds: J package	300°C
Storage temperature range, $T_{stg}$	-65°C to 150°C

† Stresses beyond those listed under “absolute maximum ratings” may cause permanent damage to the device. These are stress ratings only, and functional operation of the device at these or any other conditions beyond those indicated under “recommended operating conditions” is not implied. Exposure to absolute-maximum-rated conditions for extended periods may affect device reliability.

- NOTES: 1. All voltage values, except differential output voltage  $V_{OD}$ , are with respect to network GND.  
 2. The package thermal impedance is calculated in accordance with JESD 51-7.

DISSIPATION RATING TABLE

PACKAGE	$T_A \leq 25^\circ\text{C}$ POWER RATING	DERATING FACTOR ABOVE $T_A = 25^\circ\text{C}$ ‡	$T_A = 70^\circ\text{C}$ POWER RATING	$T_A = 125^\circ\text{C}$ POWER RATING
FK	1375 mW	11.0 mW/°C	880 mW	275 mW
J	1375 mW	11.0 mW/°C	880 mW	275 mW

‡ This is the inverse of the traditional junction-to-ambient thermal resistance ( $R\theta_{JA}$ ). Thermal resistances are not production tested and the values given are for informational purposes only.

## recommended operating conditions

		MIN	NOM	MAX	UNIT
$V_{CC}$ Supply voltage	AM26LS31C	4.75	5	5.25	V
	AM26LS31M	4.5	5	5.5	
$V_{IH}$ High-level input voltage		2			V
$V_{IL}$ Low-level input voltage					0.8 V
$I_{OH}$ High-level output current					-20 mA
$I_{OL}$ Low-level output current					20 mA
$T_A$ Operating free-air temperature	AM26LS31C	0		70	°C
	AM26LS31M	-55		125	



electrical characteristics over operating free-air temperature range (unless otherwise noted)†

PARAMETER	TEST CONDITIONS	MIN	TYP‡	MAX	UNIT
V <sub>IK</sub> Input clamp voltage	V <sub>CC</sub> = MIN, I <sub>I</sub> = -18 mA			-1.5	V
V <sub>OH</sub> High-level output voltage	V <sub>CC</sub> = MIN, I <sub>OH</sub> = -20 mA	T <sub>A</sub> = -55°C		2.4	V
		All other temperatures		2.5	
V <sub>OL</sub> Low-level output voltage	V <sub>CC</sub> = MIN, I <sub>OL</sub> = 20 mA			0.5	V
I <sub>OZ</sub> Off-state (high-impedance-state) output current	V <sub>CC</sub> = MIN	V <sub>O</sub> = 0.5 V		-20	μA
		V <sub>O</sub> = 2.5 V		20	
I <sub>I</sub> Input current at maximum input voltage	V <sub>CC</sub> = MAX, V <sub>I</sub> = 7 V			0.1	mA
I <sub>IH</sub> High-level input current	V <sub>CC</sub> = MAX, V <sub>I</sub> = 2.7 V			20	μA
I <sub>IL</sub> Low-level input current	V <sub>CC</sub> = MAX, V <sub>I</sub> = 0.4 V			-0.36	mA
I <sub>OS</sub> Short-circuit output current§	V <sub>CC</sub> = MAX	-30		-150	mA
I <sub>CC</sub> Supply current	V <sub>CC</sub> = MAX, All outputs disabled		32	80	mA

† For C suffix devices, V<sub>CC</sub> MIN = 4.75 V and V<sub>CC</sub> MAX = 5.25 V. For M suffix devices, V<sub>CC</sub> MIN = 4.5 V and V<sub>CC</sub> MAX = 5.5 V.

‡ All typical values are at V<sub>CC</sub> = 5 V and T<sub>A</sub> = 25°C.

§ Not more than one output should be shorted at a time, and duration of the short circuit should not exceed one second.

switching characteristics, V<sub>CC</sub> = 5 V, T<sub>A</sub> = 25°C (see Figure 1)

PARAMETER	TEST CONDITIONS	MIN	TYP	MAX	UNIT
t <sub>PLH</sub> Propagation delay time, low-to-high-level output	C <sub>L</sub> = 30 pF, S1 and S2 open		14	20	ns
t <sub>PHL</sub> Propagation delay time, high-to-low-level output			14	20	
t <sub>PZH</sub> Output enable time to high level	C <sub>L</sub> = 30 pF	R <sub>L</sub> = 75 Ω		25	ns
t <sub>PZL</sub> Output enable time to low level		R <sub>L</sub> = 180 Ω		37	
t <sub>PHZ</sub> Output disable time from high level	C <sub>L</sub> = 10 pF, S1 and S2 closed		21	30	ns
t <sub>PLZ</sub> Output disable time from low level			23	35	
Output-to-output skew	C <sub>L</sub> = 30 pF, S1 and S2 open		1	6	ns

# AM26LS31C, AM26LS31M QUADRUPLE DIFFERENTIAL LINE DRIVER

勝特力材料 886-3-5753170  
 勝特力电子(上海) 86-21-54151736  
 勝特力电子(深圳) 86-755-83298787  
 Http://www.100y.com.tw

SLLS114H – JANUARY 1979 – REVISED JULY 2002

## PARAMETER MEASUREMENT INFORMATION

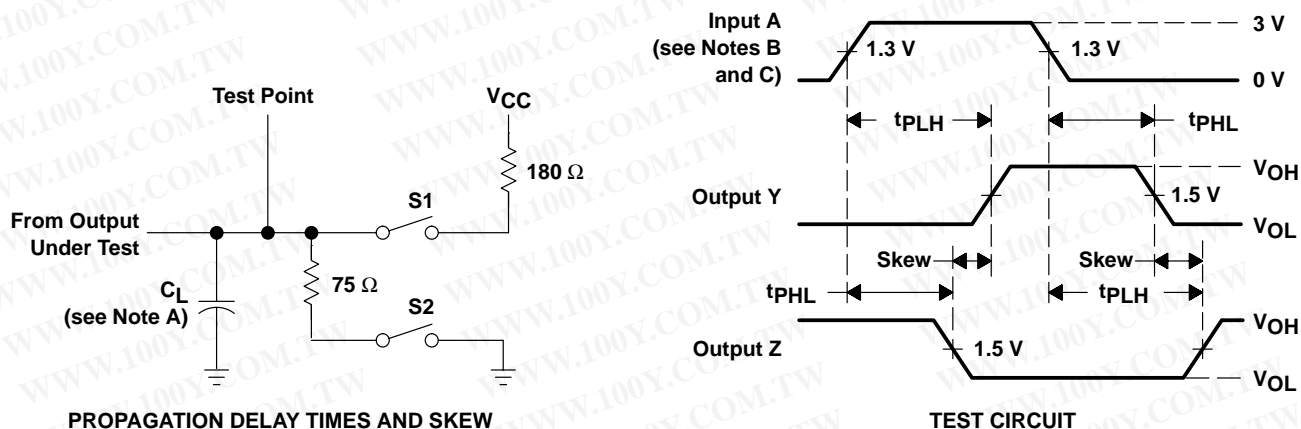

PROPAGATION DELAY TIMES AND SKEW

TEST CIRCUIT

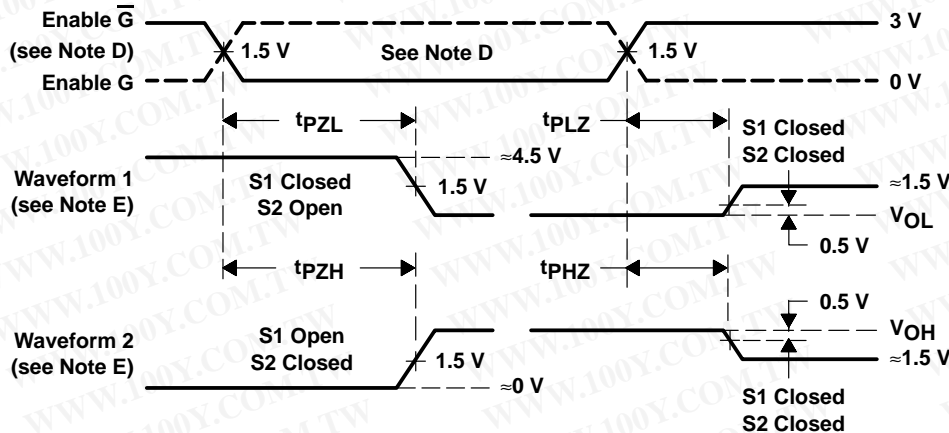

ENABLE AND DISABLE TIME WAVEFORMS

- NOTES: A.  $C_L$  includes probe and jig capacitance.  
 B. All input pulses are supplied by generators having the following characteristics:  $PRR \leq 1$  MHz,  $Z_O \approx 50 \Omega$ ,  $t_r \leq 15$  ns,  $t_f \leq 6$  ns.  
 C. When measuring propagation delay times and skew, switches S1 and S2 are open.  
 D. Each enable is tested separately.  
 E. Waveform 1 is for an output with internal conditions such that the output is low except when disabled by the output control. Waveform 2 is for an output with internal conditions such that the output is high except when disabled by the output control.

Figure 1. Test Circuit and Voltage Waveforms

TYPICAL CHARACTERISTICS

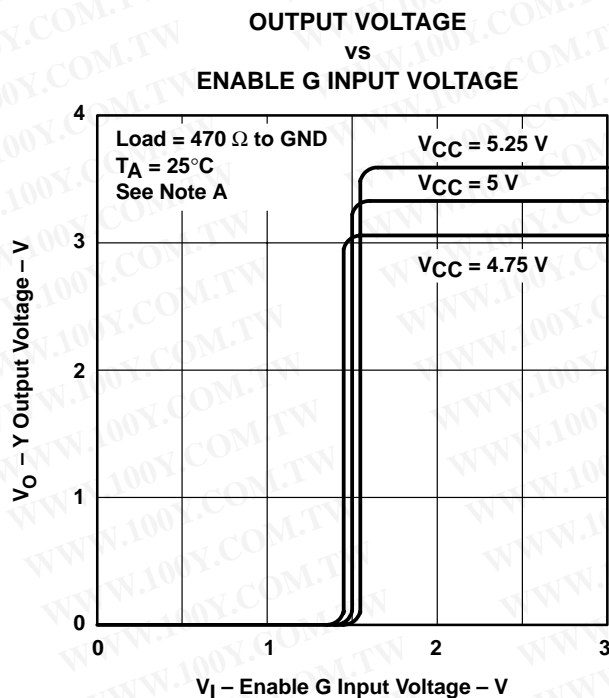

Figure 2

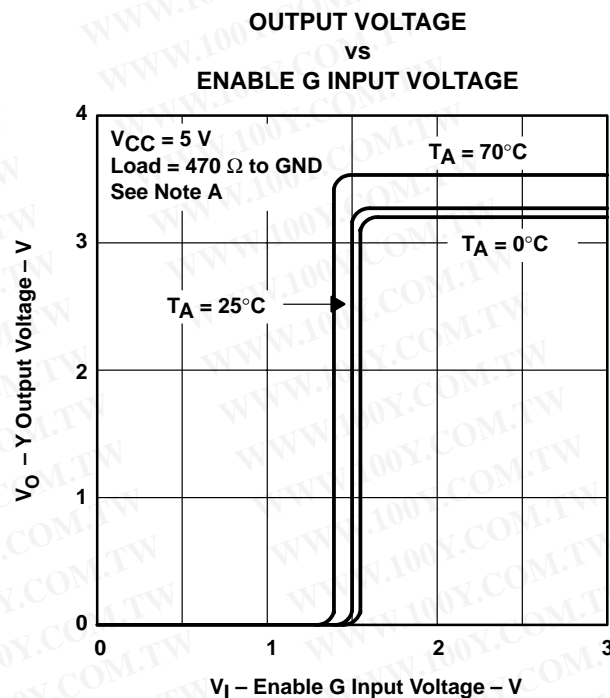

Figure 3

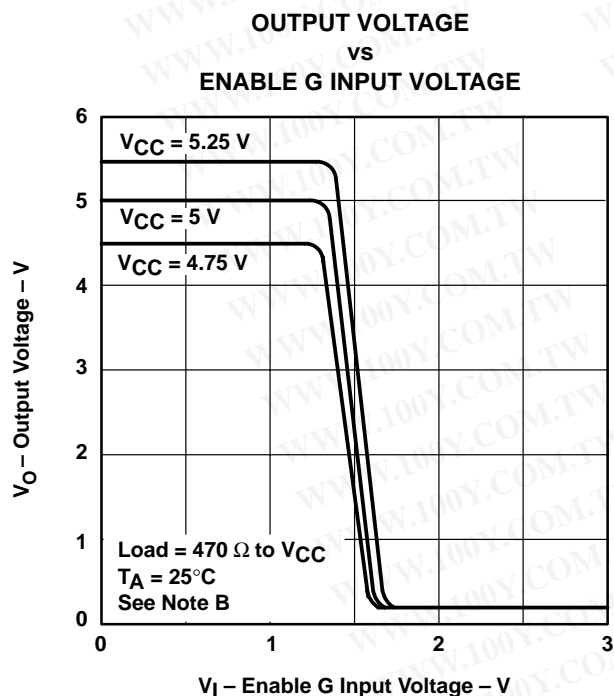

Figure 4

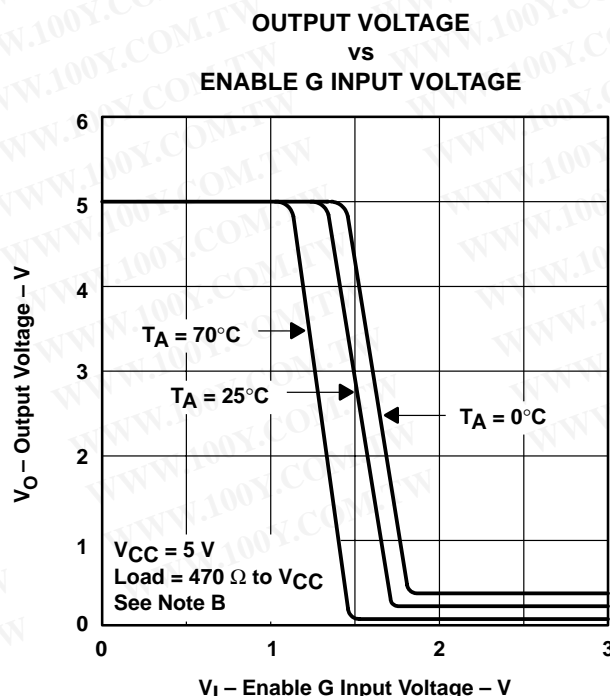

Figure 5

NOTES: A. The A input is connected to  $V_{CC}$  during testing of the Y outputs and to ground during testing of the Z outputs.  
B. The A input is connected to ground during testing of the Y outputs and to  $V_{CC}$  during testing of the Z outputs.

# AM26LS31C, AM26LS31M QUADRUPLE DIFFERENTIAL LINE DRIVER

勝特力材料 886-3-5753170  
 勝特力电子(上海) 86-21-54151736  
 勝特力电子(深圳) 86-755-83298787  
[Http://www.100y.com.tw](http://www.100y.com.tw)

SLLS114H – JANUARY 1979 – REVISED JULY 2002

## TYPICAL CHARACTERISTICS

HIGH-LEVEL OUTPUT VOLTAGE  
vs  
FREE-AIR TEMPERATURE

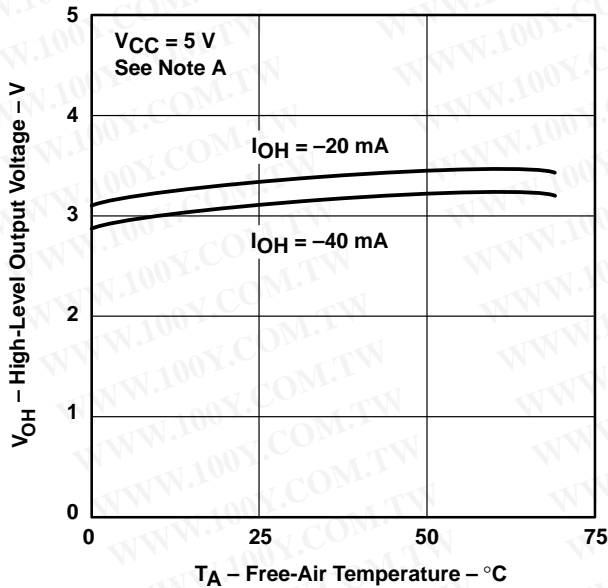

Figure 6

HIGH-LEVEL OUTPUT VOLTAGE  
vs  
HIGH-LEVEL OUTPUT CURRENT

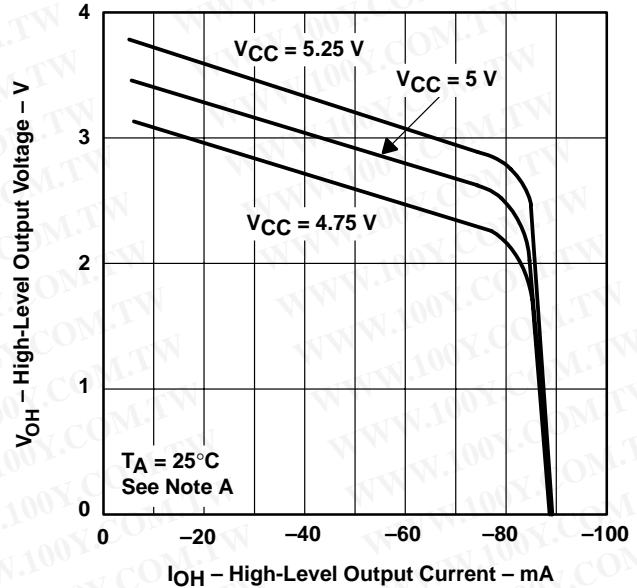

Figure 7

LOW-LEVEL OUTPUT VOLTAGE  
vs  
FREE-AIR TEMPERATURE

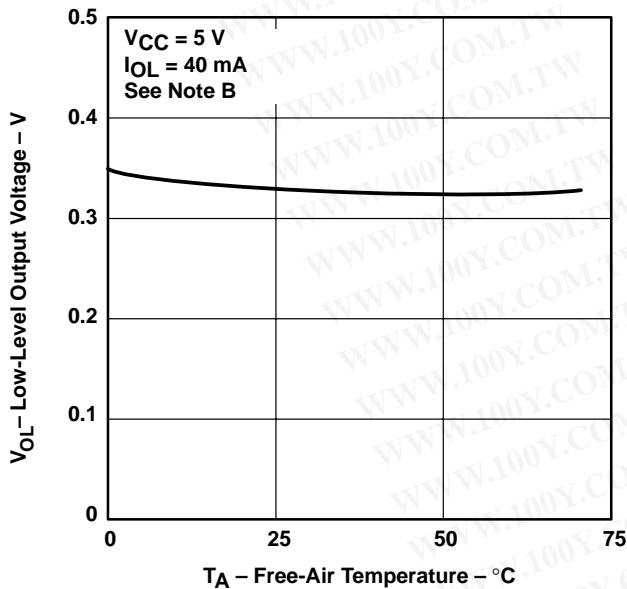

Figure 8

LOW-LEVEL OUTPUT VOLTAGE  
vs  
LOW-LEVEL OUTPUT CURRENT

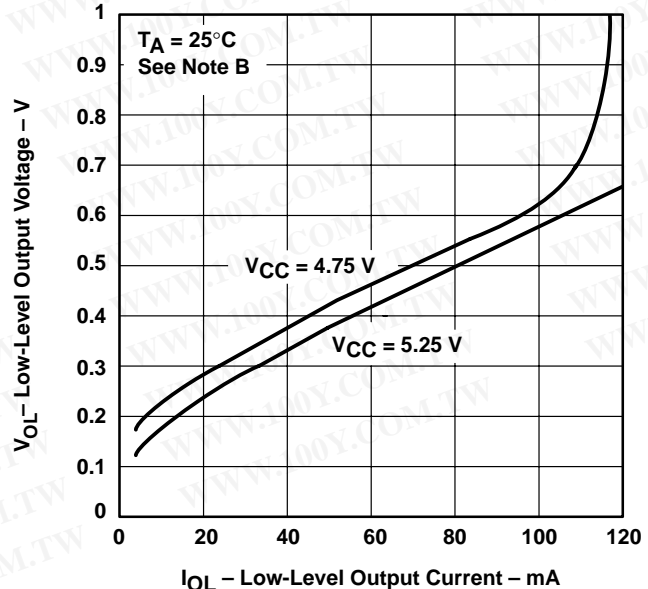
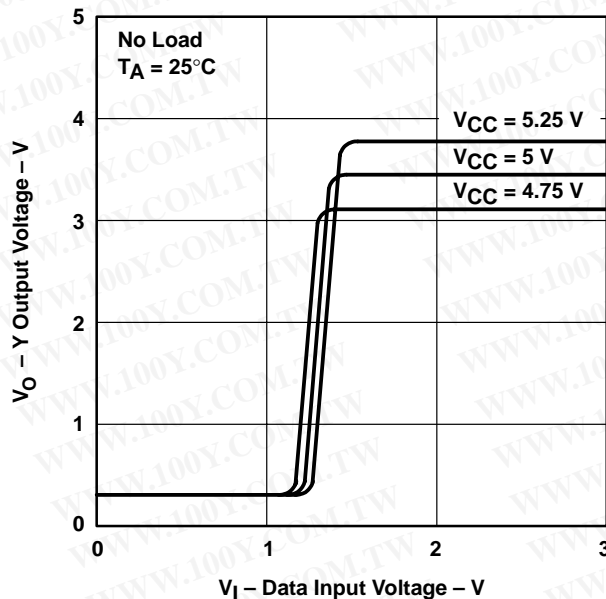

Figure 9

NOTES: A. The A input is connected to  $V_{CC}$  during testing of the Y outputs and to ground during testing of the Z outputs.  
 B. The A input is connected to ground during testing of the Y outputs and to  $V_{CC}$  during testing of the Z inputs.

**TYPICAL CHARACTERISTICS**

**Y OUTPUT VOLTAGE**  
**vs**  
**DATA INPUT VOLTAGE**



**Figure 10**

**Y OUTPUT VOLTAGE**  
**vs**  
**DATA INPUT VOLTAGE**

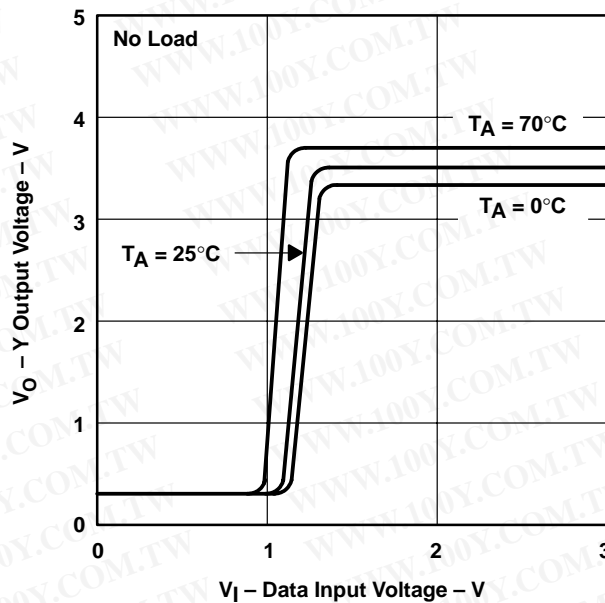

**Figure 11**

勝特力材料 886-3-5753170  
勝特力电子(上海) 86-21-54151736  
勝特力电子(深圳) 86-755-83298787  
[Http://www.100y.com.tw](http://www.100y.com.tw)

#### IMPORTANT NOTICE

Texas Instruments Incorporated and its subsidiaries (TI) reserve the right to make corrections, modifications, enhancements, improvements, and other changes to its products and services at any time and to discontinue any product or service without notice. Customers should obtain the latest relevant information before placing orders and should verify that such information is current and complete. All products are sold subject to TI's terms and conditions of sale supplied at the time of order acknowledgment.

TI warrants performance of its hardware products to the specifications applicable at the time of sale in accordance with TI's standard warranty. Testing and other quality control techniques are used to the extent TI deems necessary to support this warranty. Except where mandated by government requirements, testing of all parameters of each product is not necessarily performed.

TI assumes no liability for applications assistance or customer product design. Customers are responsible for their products and applications using TI components. To minimize the risks associated with customer products and applications, customers should provide adequate design and operating safeguards.

TI does not warrant or represent that any license, either express or implied, is granted under any TI patent right, copyright, mask work right, or other TI intellectual property right relating to any combination, machine, or process in which TI products or services are used. Information published by TI regarding third-party products or services does not constitute a license from TI to use such products or services or a warranty or endorsement thereof. Use of such information may require a license from a third party under the patents or other intellectual property of the third party, or a license from TI under the patents or other intellectual property of TI.

Reproduction of information in TI data books or data sheets is permissible only if reproduction is without alteration and is accompanied by all associated warranties, conditions, limitations, and notices. Reproduction of this information with alteration is an unfair and deceptive business practice. TI is not responsible or liable for such altered documentation.

Resale of TI products or services with statements different from or beyond the parameters stated by TI for that product or service voids all express and any implied warranties for the associated TI product or service and is an unfair and deceptive business practice. TI is not responsible or liable for any such statements.