

FEATURES

- 44 V Supply Maximum Ratings
- V_{SS} to V_{DD} Analog Signal Range
- Low On Resistance (45 Ω max)
- Low ΔR_{ON} (5 Ω max)
- Low R_{ON} Match (4 Ω max)
- Low Power Dissipation
- Fast Switching Times
 - t_{ON} < 175 ns
 - t_{OFF} < 145 ns
- Low Leakage Currents (5 nA max)
- Low Charge Injection (10 pC max)
- Break-Before-Make Switching Action

APPLICATIONS

- Audio and Video Switching
- Battery Powered Systems
- Test Equipment
- Communication Systems

GENERAL DESCRIPTION

The ADG333A is a monolithic CMOS device comprising four independently selectable SPDT switches. It is designed on an LC²MOS process which provides low power dissipation yet achieves a high switching speed and a low on resistance.

The on resistance profile is very flat over the full analog input range ensuring good linearity and low distortion when switching audio signals. High switching speed also makes the part suitable for video signal switching. CMOS construction ensures ultralow power dissipation making the part ideally suited for portable, battery powered instruments.

When they are ON, each switch conducts equally well in both directions and has an input signal range which extends to the power supplies. In the OFF condition, signal levels up to the supplies are blocked. All switches exhibit break-before-make switching action for use in multiplexer applications. Inherent in the design is low charge injection for minimum transients when switching the digital inputs.

FUNCTIONAL BLOCK DIAGRAM

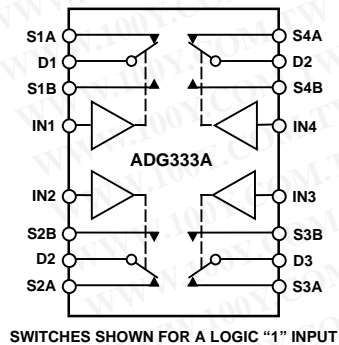

PRODUCT HIGHLIGHTS

1. Extended Signal Range
The ADG333A is fabricated on an enhanced LC²MOS process, giving an increased signal range which extends to the supply rails.
2. Low Power Dissipation
3. Low R_{ON}
4. Single Supply Operation
For applications where the analog signal is unipolar, the ADG333A can be operated from a single rail power supply. The part is fully specified with a single +12 V supply.

REV. 0

Information furnished by Analog Devices is believed to be accurate and reliable. However, no responsibility is assumed by Analog Devices for its use, nor for any infringements of patents or other rights of third parties which may result from its use. No license is granted by implication or otherwise under any patent or patent rights of Analog Devices.

© Analog Devices, Inc., 1995

One Technology Way, P.O. Box 9106, Norwood, MA 02062-9106, U.S.A.
 Tel: 617/329-4700 Fax: 617/326-8703

ADG333A—SPECIFICATIONS¹

DUAL SUPPLY ($V_{DD} = +15\text{ V}$, $V_{SS} = -15\text{ V}$, $GND = 0\text{ V}$, unless otherwise noted)

Parameter	+25°C	-40°C to +85°C	Units	Test Conditions/Comments
ANALOG SWITCH				
Analogue Signal Range		V_{SS} to V_{DD}	V	
R_{ON}	20		Ω typ	$V_D = \pm 10\text{ V}$, $I_S = -1\text{ mA}$
	45	45	Ω max	
ΔR_{ON}		5	Ω max	$V_D = \pm 5\text{ V}$, $I_S = -10\text{ mA}$
R_{ON} Match		4	Ω max	$V_D = \pm 10\text{ V}$, $I_S = -10\text{ mA}$
LEAKAGE CURRENTS				
Source OFF Leakage I_S (OFF)	± 0.1		nA typ	$V_{DD} = +16.5\text{ V}$, $V_{SS} = -16.5\text{ V}$
	± 0.25	± 3	nA max	$V_D = \pm 15.5\text{ V}$, $V_S = +15.5\text{ V}$
Channel ON Leakage I_D , I_S (ON)	± 0.1		nA typ	Test Circuit 2
	± 0.4	± 5	nA max	$V_S = V_D = \pm 15.5\text{ V}$
				Test Circuit 3
DIGITAL INPUTS				
Input High Voltage, V_{INH}		2.4	V min	
Input Low Voltage, V_{INL}		0.8	V max	
Input Current				
I_{INL} or I_{INH}		± 0.005	μA typ	$V_{IN} = 0\text{ V}$ or V_{DD}
		± 0.5	μA max	
DYNAMIC CHARACTERISTICS²				
t_{ON}	90		ns typ	$R_L = 300\ \Omega$, $C_L = 35\text{ pF}$;
		175	ns max	$V_S = \pm 10\text{ V}$; Test Circuit 4
t_{OFF}	80		ns typ	$R_L = 300\ \Omega$, $C_L = 35\text{ pF}$;
		145	ns max	$V_S = \pm 10\text{ V}$; Test Circuit 4
Break-Before-Make Delay, t_{OPEN}	10		ns min	$R_L = 300\ \Omega$, $C_L = 35\text{ pF}$;
Charge Injection	2		pC typ	$V_S = +5\text{ V}$; Test Circuit 5
	10		pC max	$V_D = 0\text{ V}$, $R_D = 0\ \Omega$, $C_L = 10\text{ nF}$;
OFF Isolation	72		dB typ	$V_{DD} = +15\text{ V}$, $V_{SS} = -15\text{ V}$; Test Circuit 6
Channel-to-Channel Crosstalk	85		dB typ	$R_L = 75\ \Omega$, $C_L = 5\text{ pF}$, $f = 1\text{ MHz}$;
				$V_S = 2.3\text{ V rms}$, Test Circuit 7
C_S (OFF)	5		pF typ	$R_L = 75\ \Omega$, $C_L = 5\text{ pF}$, $f = 1\text{ MHz}$;
C_D , C_S (ON)	20		pF typ	$V_S = 2.3\text{ V rms}$, Test Circuit 8
POWER REQUIREMENTS				
I_{DD}	0.05		mA typ	Digital Inputs = 0 V or 5 V
	0.25	0.35	mA max	
I_{SS}	0.01		μA typ	
	1	5	μA max	
V_{DD}/V_{SS}		$\pm 3/\pm 20$	V min/V max	$ V_{DD} = V_{SS} $

NOTES

¹Temperature range is as follows: B Version: -40°C to $+85^\circ\text{C}$.

²Guaranteed by design, not subject to production test.

Specifications subject to change without notice.

勝特力材料 886-3-5753170
 勝特力电子(上海) 86-21-54151736
 勝特力电子(深圳) 86-755-83298787
[Http://www.100y.com.tw](http://www.100y.com.tw)

SINGLE SUPPLY ($V_{DD} = +12\text{ V}$, $V_{SS} = 0\text{ V} \pm 10\%$, $GND = 0\text{ V}$, unless otherwise noted)

Parameter	+25°C	-40°C to +85°C	Units	Test Conditions/Comments
ANALOG SWITCH Analog Signal Range R_{ON}	35	0 to V_{DD} 75	V Ω typ Ω max	$V_D = +1\text{ V}$, $+10\text{ V}$, $I_S = -1\text{ mA}$
LEAKAGE CURRENTS Source OFF Leakage I_S (OFF) Channel ON Leakage I_D , I_S (ON)	± 0.1 ± 0.25 ± 0.1 ± 0.4	± 3 ± 5	nA typ nA max nA typ nA max	$V_{DD} = +13.2\text{ V}$ $V_D = 12.2\text{ V}/1\text{ V}$, $V_S = 1\text{ V}/12.2\text{ V}$ Test Circuit 2 $V_S = V_D = 12.2\text{ V}/1\text{ V}$ Test Circuit 3
DIGITAL INPUTS Input High Voltage, V_{INH} Input Low Voltage, V_{INL} Input Current I_{INL} or I_{INH}		2.4 0.8 ± 0.005 ± 0.5	V min V max μA typ μA max	$V_{IN} = 0\text{ V}$ or V_{DD}
DYNAMIC CHARACTERISTICS ² t_{ON} t_{OFF} Break-Before-Make Delay, t_{OPEN} Charge Injection OFF Isolation Channel-to-Channel Crosstalk C_S (OFF) C_D , C_S (ON)	110 100 10 5 72 85 5 20	200 180	ns typ ns max ns typ ns max ns min ns min pC typ dB typ dB typ pF typ pF typ	$R_L = 300\ \Omega$, $C_L = 35\text{ pF}$; $V_S = +8\text{ V}$; Test Circuit 4 $R_L = 300\ \Omega$, $C_L = 35\text{ pF}$; $V_S = +8\text{ V}$; Test Circuit 4 $R_L = 300\ \Omega$, $C_L = 35\text{ pF}$; $V_S = +5\text{ V}$; Test Circuit 5 $V_D = 6\text{ V}$, $R_D = 0\ \Omega$, $C_L = 10\text{ nF}$; $V_{DD} = +12\text{ V}$, $V_{SS} = -0\text{ V}$; Test Circuit 6 $R_L = 75\ \Omega$, $C_L = 5\text{ pF}$, $f = 1\text{ MHz}$; $V_S = 1.15\text{ V rms}$, Test Circuit 7 $R_L = 75\ \Omega$, $C_L = 5\text{ pF}$, $f = 1\text{ MHz}$; $V_S = 1.15\text{ V rms}$, Test Circuit 8
POWER REQUIREMENTS I_{DD} V_{DD}	0.05 0.25	0.35 +3/+30	mA typ mA max V min/V max	$V_{DD} = +13.5\text{ V}$ Digital Inputs = 0 V or 5 V

NOTES

¹Temperature range is as follows: B Version: -40°C to $+85^\circ\text{C}$.²Guaranteed by design, not subject to production test.

Specifications subject to change without notice.

勝特力材料 886-3-5753170
 勝特力电子(上海) 86-21-54151736
 勝特力电子(深圳) 86-755-83298787
[Http://www.100y.com.tw](http://www.100y.com.tw)

ADG333A

ABSOLUTE MAXIMUM RATINGS¹

(T_A = +25°C unless otherwise noted)

V _{DD} to V _{SS}	+44 V
V _{DD} to GND	-0.3 V to +30 V
V _{SS} to GND	+0.3 V to -30 V
Analog, Digital Inputs ²	V _{SS} - 2 V to V _{DD} + 2 V or 20 mA, Whichever Occurs First
Continuous Current, S or D	20 mA
Peak Current, S or D	40 mA (Pulsed at 1 ms, 10% Duty Cycle Max)
Operating Temperature Range	
Industrial (B Version)	-40°C to +85°C
Storage Temperature Range	-65°C to +125°C
Junction Temperature	+150°C
Plastic Package	
θ _{JA} , Thermal Impedance	103°C/W
Lead Temperature, Soldering (10 sec)	+260°C

SOIC Package

θ _{JA} , Thermal Impedance	74°C/W
Lead Temperature, Soldering	
Vapor Phase (60 sec)	+215°C
Infrared (15 sec)	+220°C

SSOP Package

θ _{JA} , Thermal Impedance	130°C/W
Lead Temperature, Soldering	
Vapor Phase (60 sec)	+215°C
Infrared (15 sec)	+220°C

NOTES

¹Stresses above those listed under “Absolute Maximum Ratings” may cause permanent damage to the device. This is a stress rating only and functional operation of the device at these or any other conditions above those listed in the operational sections of this specification is not implied. Exposure to absolute maximum rating conditions for extended periods may affect device reliability. Only one absolute maximum rating may be applied at any one time.

²Overvoltages at IN, S or D will be clamped by internal diodes. Current should be limited to the maximum ratings given.

CAUTION

ESD (electrostatic discharge) sensitive device. Electrostatic charges as high as 4000 V readily accumulate on the human body and test equipment and can discharge without detection. Although the ADG333A features proprietary ESD protection circuitry, permanent damage may occur on devices subjected to high energy electrostatic discharges. Therefore, proper ESD precautions are recommended to avoid performance degradation or loss of functionality.



ORDERING GUIDE

Model	Temperature Range	Package Option*
ADG333ABN	-40°C to +85°C	N-20
ADG333ABR	-40°C to +85°C	R-20
ADG333ABRS	-40°C to +85°C	RS-20

*N = Plastic DIP, R = Small Outline IC (SOIC). RS = Shrink Small Outline Package (SSOP).

Table I. Truth Table

Logic	Switch A	Switch B
0	OFF	ON
1	ON	OFF

勝特力材料 886-3-5753170
 勝特力电子(上海) 86-21-54151736
 勝特力电子(深圳) 86-755-83298787
[Http://www.100y.com.tw](http://www.100y.com.tw)

TERMINOLOGY

S	Source Terminal. May be an input or output.	C_D, C_S (ON)	“ON” Switch Capacitance.
D	Drain Terminal. May be an input or output.	t_{ON}	Delay between applying the digital control input and the output switching on.
IN	Logic Control Input.	t_{OFF}	Delay between applying the digital control input and the output switching off.
R_{ON}	Ohmic resistance between D and S.	t_{OPEN}	Break Before Make delay when switches are configured as a multiplexer.
ΔR_{ON}	R_{ON} variation due to a change in the analog input voltage with a constant load current.	V_{INL}	Maximum input voltage for logic “0.”
R_{ON} Match	Difference between the R_{ON} of any two channels.	V_{INH}	Minimum input voltage for logic “1.”
I_S (OFF)	Source leakage current with the switch “OFF.”	I_{INL} (I_{INH})	Input current of the digital input.
I_D (OFF)	Drain leakage current with the switch “OFF.”	Crosstalk	A measure of unwanted signal which is coupled through from one channel to another as a result of parasitic capacitance.
I_D, I_S (ON)	Channel leakage current with the switch “ON.”	Off Isolation	A measure of unwanted signal coupling through an “OFF” switch.
V_D (V_S)	Analog voltage on terminals D, S.	Charge Injection	A measure of the glitch impulse transferred from the digital input to the analog output during switching.
C_S (OFF)	“OFF” Switch Source Capacitance.		
C_D (OFF)	“OFF” Switch Drain Capacitance.		

PIN CONFIGURATION

DIP/SOIC/SSOP

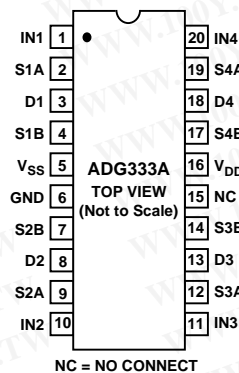

勝特力材料 886-3-5753170
 勝特力电子(上海) 86-21-54151736
 勝特力电子(深圳) 86-755-83298787
[Http://www.100y.com.tw](http://www.100y.com.tw)

ADG333A–Typical Performance Graphs

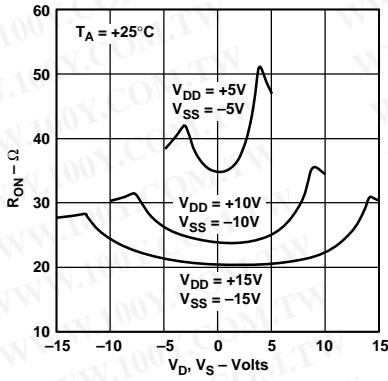

Figure 1. R_{ON} as a Function of V_D (V_S): Dual Supply

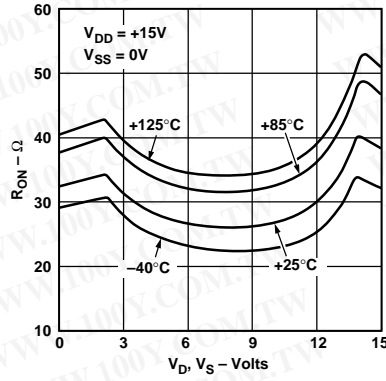

Figure 4. R_{ON} as a Function of V_D (V_S) for Different Temperatures: Single Supply

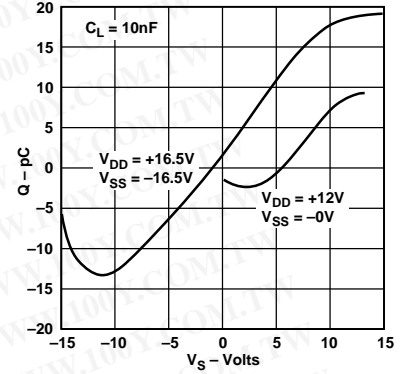

Figure 7. Charge Injection as a Function of V_S

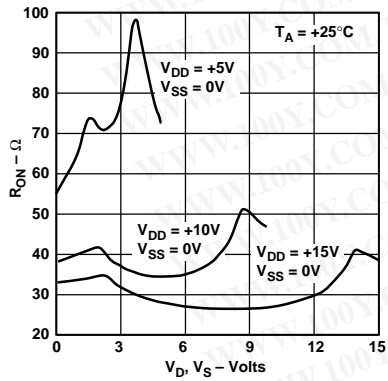

Figure 2. R_{ON} as a Function of V_D (V_S): Single Power Supply

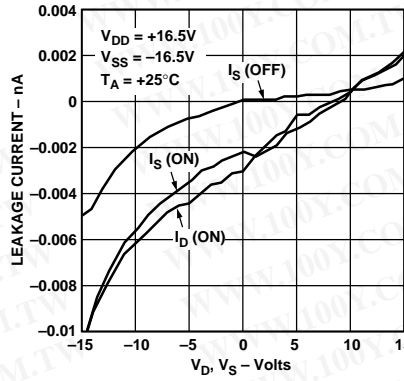

Figure 5. Leakage Currents as a Function of V_D (V_S): Dual Supply

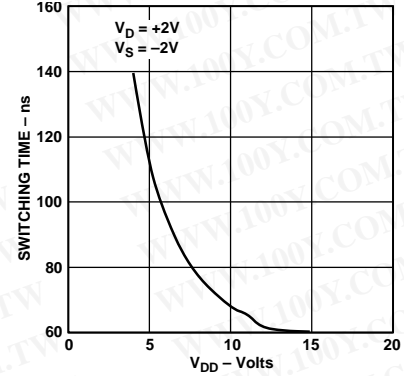

Figure 8. Switching Time as a Function of V_{DD}

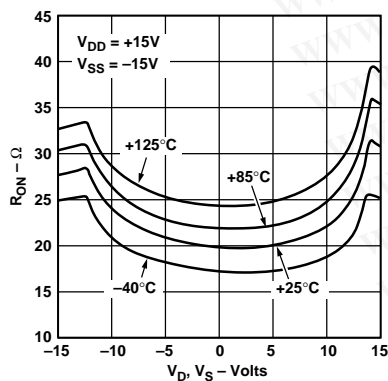

Figure 3. R_{ON} as a Function of V_D (V_S) for Different Temperatures: Dual Supply

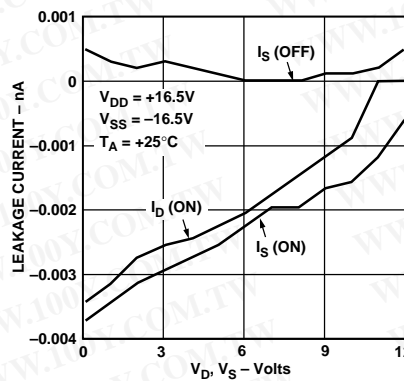

Figure 6. Leakage Currents as a Function of V_D (V_S): Single Supply

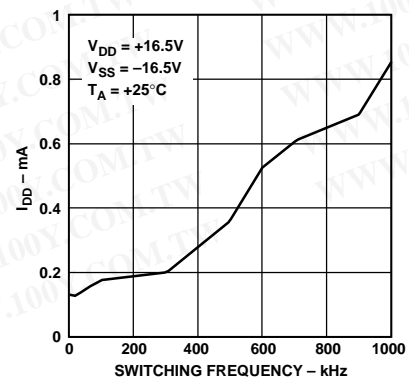
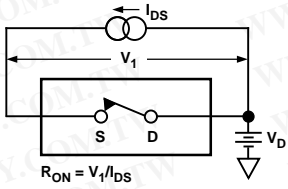
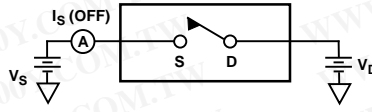

Figure 9. I_{DD} as a Function of Switching Frequency

勝特力材料 886-3-5753170
 勝特力电子(上海) 86-21-54151736
 勝特力电子(深圳) 86-755-83298787
[Http://www.100y.com.tw](http://www.100y.com.tw)



Test Circuit 1. On Resistance



Test Circuit 2. Off Leakage

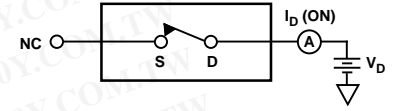

Test Circuit 3. On Leakage

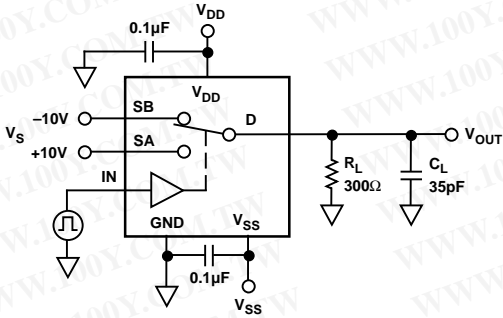

Test Circuit 4. Switching Times

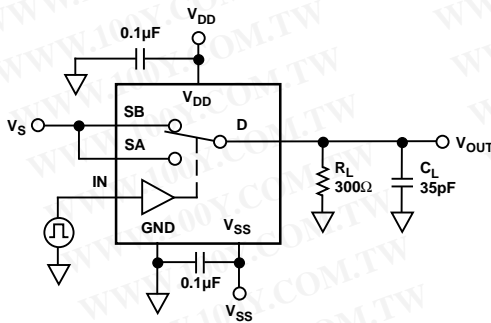
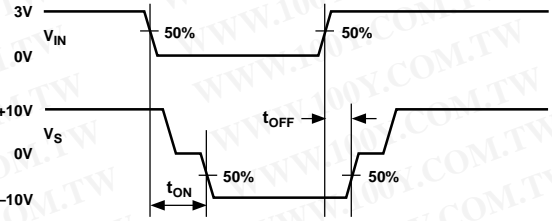

Test Circuit 5. Break-Before-Make Delay, t_{OPEN}

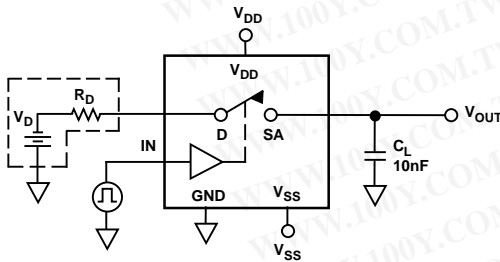
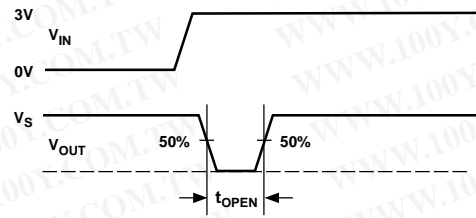

Test Circuit 6. Charge Injection

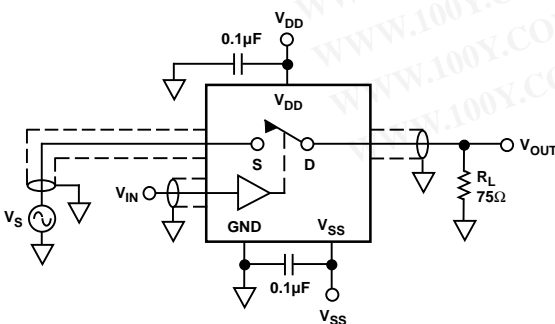
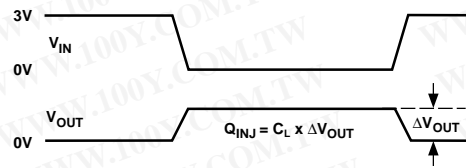

Test Circuit 7. Off Isolation

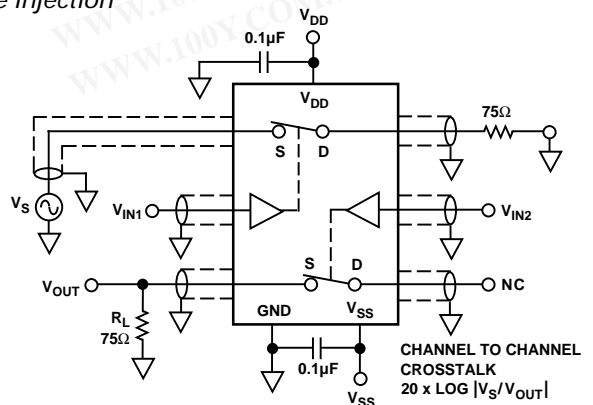

Test Circuit 8. Channel-to-Channel Crosstalk
CHANNEL TO CHANNEL CROSSTALK $20 \times \text{LOG} |V_S/V_{OUT}|$

ADG333A

APPLICATIONS INFORMATION

ADG333A Supply Voltages

The ADG333A can operate off a dual or signal supply. V_{SS} should be connected to GND when operating with a single supply. When using a dual supply the ADG333A can also operate with unbalanced supplies, for example $V_{DD} = 20\text{ V}$ and $V_{SS} = -5\text{ V}$. The only restrictions are that V_{DD} to GND must not exceed 30 V, V_{SS} to GND must not drop below -30 V and V_{DD} to V_{SS} must not exceed +44 V. It is important to remember that the ADG333A supply voltage directly affects the input signal range, the switch ON resistance and the switching times of the part. The effects of the power supplies on these characteristics

can be clearly seen from the characteristic curves in this data sheet.

Power Supply Sequencing

When using CMOS devices care must be taken to ensure correct power-supply sequencing. Incorrect power-supply sequencing can result in the device being subjected to stresses beyond those maximum ratings listed in the data sheet. This is also true for the ADG333A. Always sequence V_{DD} on first followed by V_{SS} and the logic signals. An external signal within the maximum specified ratings can then be safely presented to the source or drain of the switch

OUTLINE DIMENSIONS

Dimensions shown in inches and (mm).

20-Pin Plastic DIP (N-20)

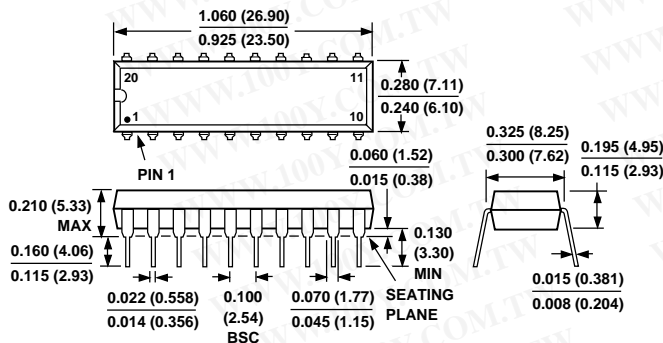

20-Pin SOIC (R-20)

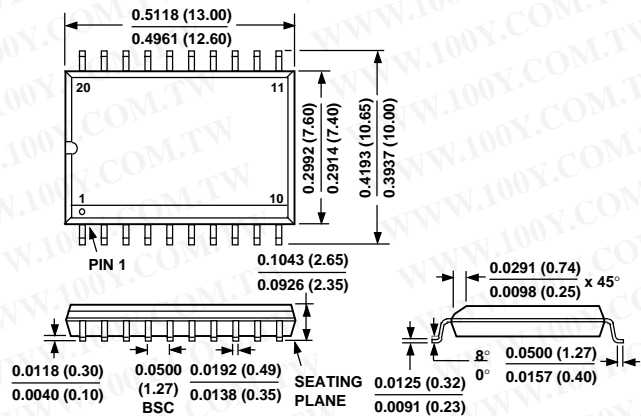

20-Pin SSOP (RS-20)

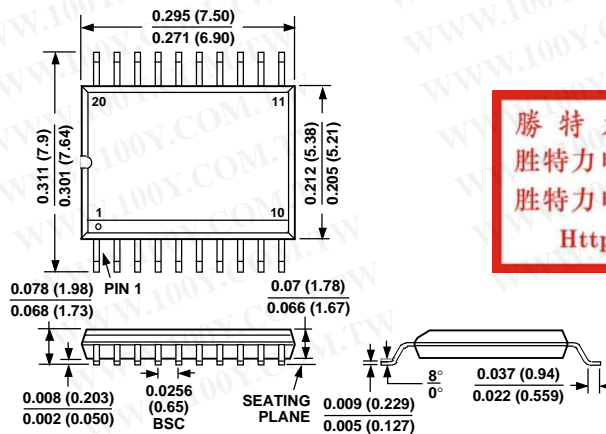

LEADS WILL BE EITHER TIN PLATED OR SOLDIER DIPPED IN ACCORDANCE WITH MIL-M-38510 REQUIREMENTS

勝特力材料 886-3-5753170
 勝特力电子(上海) 86-21-54151736
 勝特力电子(深圳) 86-755-83298787
[Http://www.100y.com.tw](http://www.100y.com.tw)

C2076-18-10/95

PRINTED IN U.S.A.