

# Fractional-N Frequency Synthesizer

## ADF4153

### FEATURES

- RF bandwidth 500 MHz to 4 GHz
- 2.7 V to 3.3 V power supply
- Separate  $V_P$  allows extended tuning voltage
- Programmable dual-modulus prescaler 4/5, 8/9
- Programmable charge pump currents
- 3-wire serial interface
- Analog and digital lock detect
- Power-down mode
- Pin compatible with the ADF4110/ADF4111/ADF4112/ADF4113 and ADF4106
- Programmable modulus on fractional-N synthesizer
- Trade-off noise versus spurious performance

### APPLICATIONS

- CATV equipment
- Base stations for mobile radio (GSM, PCS, DCS, CDMA, WCDMA)
- Wireless handsets (GSM, PCS, DCS, CDMA, WCDMA)
- Wireless LANs
- Communications test equipment

### GENERAL DESCRIPTION

The ADF4153 is a fractional-N frequency synthesizer that implements local oscillators in the upconversion and downconversion sections of wireless receivers and transmitters. It consists of a low noise digital phase frequency detector (PFD), a precision charge pump, and a programmable reference divider. There is a  $\Sigma$ - $\Delta$  based fractional interpolator to allow programmable fractional-N division. The INT, FRAC, and MOD registers define an overall N divider ( $N = (\text{INT} + (\text{FRAC}/\text{MOD}))$ ). In addition, the 4-bit reference counter (R counter) allows selectable REF frequencies at the PFD input. A complete phase-locked loop (PLL) can be implemented if the synthesizer is used with an external loop filter and a voltage controlled oscillator (VCO).

Control of all on-chip registers is via a simple 3-wire interface. The device operate with a power supply ranging from 2.7 V to 3.3 V and can be powered down when not in use.

### FUNCTIONAL BLOCK DIAGRAM

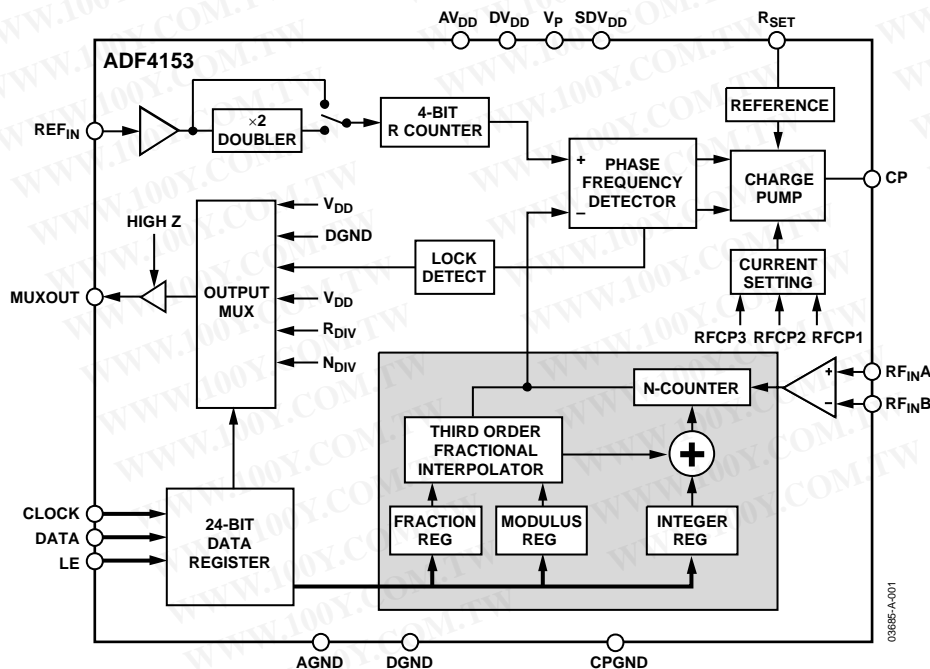

Figure 1.

### Rev. A

Information furnished by Analog Devices is believed to be accurate and reliable. However, no responsibility is assumed by Analog Devices for its use, nor for any infringements of patents or other rights of third parties that may result from its use. Specifications subject to change without notice. No license is granted by implication or otherwise under any patent or patent rights of Analog Devices. Trademarks and registered trademarks are the property of their respective owners.

**TABLE OF CONTENTS**

Specifications.....	3	R Divider Register, R1 .....	17
Timing Characteristics.....	5	Control Register, R2 .....	17
Absolute Maximum Ratings.....	6	Noise and Spur Register, R3 .....	18
ESD Caution.....	6	Reserved Bits .....	18
Pin Configuration and Pin Function Descriptions.....	7	RF Synthesizer: A Worked Example .....	18
Typical Performance Characteristics .....	8	Modulus.....	19
Circuit Description.....	10	Reference Doubler and Reference Divider .....	19
Reference Input Section.....	10	12-Bit Programmable Modulus.....	19
RF Input Stage.....	10	Spurious Optimization and Fastlock .....	19
RF INT Divider.....	10	Phase Resync and Spur Consistency .....	19
INT, FRAC, MOD, and R Relationship.....	10	Spurious Signals—Predicting Where They Will Appear.....	20
RF R COUNTER .....	10	Filter Design—ADIsimPLL.....	20
Phase Frequency Detector (PFD) and Charge Pump.....	11	Interfacing .....	20
MUXOUT and LOCK Detect.....	11	PCB Design Guidelines for Chip Scale Package .....	21
Input Shift Registers .....	11	Outline Dimensions .....	22
Program Modes .....	11	Ordering Guide .....	22
N Divider Register, R0 .....	17		

**REVISION HISTORY**

1/04—Data Sheet Changed from a REV. 0 to a REV. A

Renumbered Figures and Tables.....	UNIVERSAL
Changes to Specifications .....	3
Changes to Pin Function Description .....	7
Changes to RF Power-Down section .....	17
Changes to PCB Design Guidelines for Chip Scale Package section .....	21
Updated Outline Dimensions .....	22
Updated Ordering Guide.....	22

7/03—Revision 0: Initial Version

## SPECIFICATIONS<sup>1</sup>

$AV_{DD} = DV_{DD} = SDV_{DD} = 2.7\text{ V to }3.3\text{ V}$ ;  $V_P = AV_{DD}$  to  $5.5\text{ V}$ ;  $AGND = DGND = 0\text{ V}$ ;  $T_A = T_{MIN}$  to  $T_{MAX}$ , unless otherwise noted; dBm referred to  $50\ \Omega$ .

Table 1.

Parameter	B Version	Unit	Test Conditions/Comments
<b>RF CHARACTERISTICS (3 V)</b>			
RF Input Frequency ( $RF_{IN}$ ) <sup>2</sup>	0.5/4.0	GHz min/max	See Figure 17 for input circuit. –8 dBm/0 dBm min/max. For lower frequencies, ensure slew rate (SR) > 396 V/μs.
	1.0/4.0	GHz min/max	–10 dBm/0 dBm min/max.
<b>REFERENCE CHARACTERISTICS</b>			
$REF_{IN}$ Input Frequency <sup>2</sup>	10/250	MHz min/max	See Figure 16 for input circuit. For $f < 10\text{ MHz}$ , use a dc-coupled CMOS compatible square wave, slew rate > 21 V/μs.
$REF_{IN}$ Input Sensitivity	0.7/ $AV_{DD}$	V p-p min/max	AC-coupled.
	0 to $AV_{DD}$	V max	CMOS compatible.
$REF_{IN}$ Input Capacitance	10	pF max	
$REF_{IN}$ Input Current	±100	μA max	
<b>PHASE DETECTOR</b>			
Phase Detector Frequency <sup>3</sup>	32	MHz max	
<b>CHARGE PUMP</b>			
$I_{CP}$ Sink/Source			Programmable. See Table 5.
High Value	5	mA typ	With $R_{SET} = 5.1\text{ k}\Omega$ .
Low Value	312.5	μA typ	
Absolute Accuracy	2.5	% typ	With $R_{SET} = 5.1\text{ k}\Omega$ .
$R_{SET}$ Range	1.5/10	kΩ min/max	
$I_{CP}$ Three-State Leakage Current	1	nA typ	Sink and source current.
Matching	2	% typ	$0.5\text{ V} < V_{CP} < V_P - 0.5$ .
$I_{CP}$ vs. $V_{CP}$	2	% typ	$0.5\text{ V} < V_{CP} < V_P - 0.5$ .
$I_{CP}$ vs. Temperature	2	% typ	$V_{CP} = V_P/2$ .
<b>LOGIC INPUTS</b>			
$V_{INH}$ , Input High Voltage	1.4	V min	
$V_{INL}$ , Input Low Voltage	0.6	V max	
$I_{INH}/I_{INL}$ , Input Current	±1	μA max	
$C_{IN}$ , Input Capacitance	10	pF max	
<b>LOGIC OUTPUTS</b>			
$V_{OH}$ , Output High Voltage	1.4	V min	Open-drain 1 kΩ pull-up to 1.8 V.
$V_{OL}$ , Output Low Voltage	0.4	V max	$I_{OL} = 500\ \mu\text{A}$ .
<b>POWER SUPPLIES</b>			
$AV_{DD}$	2.7/3.3	V min/V max	
$DV_{DD}$ , $SDV_{DD}$	$AV_{DD}$		
$V_P$	$AV_{DD}/5.5$	V min/V max	
$I_{DD}$ <sup>4</sup>	24	mA max	20 mA typical.
Low Power Sleep Mode	1	μA typ	
<b>NOISE CHARACTERISTICS</b>			
Phase Noise Figure of Merit <sup>5</sup>	–217	dBc/Hz typ	
ADF4153 Phase Noise Floor <sup>6</sup>	–147	dBc/Hz typ	@ 10 MHz PFD frequency.
	–143	dBc/Hz typ	@ 26 MHz PFD frequency.
Phase Noise Performance <sup>7</sup>			@ VCO output.
1750 MHz Output <sup>8</sup>	–106	dBc/Hz typ	@ 1 kHz offset, 26 MHz PFD frequency.

See footnotes on next page.

# ADF4153

勝特力材料 886-3-5753170  
勝特力电子(上海) 86-21-54151736  
勝特力电子(深圳) 86-755-83298787  
[Http://www.100y.com.tw](http://www.100y.com.tw)

<sup>1</sup> Operating temperature is B version:  $-40^{\circ}\text{C}$  to  $+80^{\circ}\text{C}$ .

<sup>2</sup> Use a square wave for frequencies below  $f_{\text{MIN}}$ .

<sup>3</sup> Guaranteed by design. Sample tested to ensure compliance.

<sup>4</sup> AC coupling ensures  $AV_{\text{DD}}/2$  bias. See Figure 16 for typical circuit.

<sup>5</sup> This figure can be used to calculate phase noise for any application. Use the formula  $-217 + 10\log(f_{\text{PFD}}) + 20\log N$  to calculate in-band phase noise performance as seen at the VCO output. The value given is the lowest noise mode.

<sup>6</sup> The synthesizer phase noise floor is estimated by measuring the in-band phase noise at the output of the VCO and subtracting  $20\log N$  (where N is the N divider value). The value given is the lowest noise mode.

<sup>7</sup> The phase noise is measured with the EVAL-ADF4153EB1 evaluation board and the HP8562E spectrum analyzer.

<sup>8</sup>  $f_{\text{REFIN}} = 26 \text{ MHz}$ ;  $f_{\text{PFD}} = 10 \text{ MHz}$ ; offset frequency = 1 kHz;  $\text{RF}_{\text{OUT}} = 1750 \text{ MHz}$ ;  $N = 175$ ; loop B/W = 20 kHz; lowest noise mode.

## TIMING CHARACTERISTICS<sup>1</sup>

$AV_{DD} = DV_{DD} = SDV_{DD} = 2.7\text{ V to }3.3\text{ V}$ ;  $V_P = AV_{DD}$  to  $5.5\text{ V}$ ;  $AGND = DGND = 0\text{ V}$ ;  $T_A = T_{MIN}$  to  $T_{MAX}$ , unless otherwise noted; dBm referred to  $50\ \Omega$ .

Table 2.

Parameter	Limit at $T_{MIN}$ to $T_{MAX}$ (B Version)	Unit	Test Conditions/Comments
$t_1$	20	ns min	LE Setup Time
$t_2$	10	ns min	DATA to CLOCK Setup Time
$t_3$	10	ns min	DATA to CLOCK Hold Time
$t_4$	25	ns min	CLOCK High Duration
$t_5$	25	ns min	CLOCK Low Duration
$t_6$	10	ns min	CLOCK to LE Setup Time
$t_7$	20	ns min	LE Pulse Width

<sup>1</sup> Guaranteed by design but not production tested.

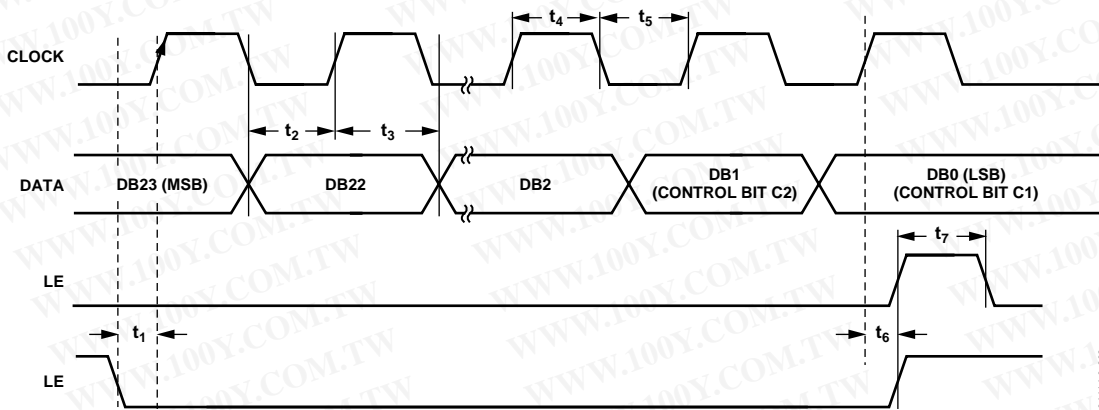

Figure 2. Timing Diagram

04414-002

# ADF4153

勝特力材料 886-3-5753170  
勝特力电子(上海) 86-21-54151736  
勝特力电子(深圳) 86-755-83298787  
[Http://www.100y.com.tw](http://www.100y.com.tw)

## ABSOLUTE MAXIMUM RATINGS<sup>1, 2, 3, 4</sup>

T<sub>A</sub> = 25°C, unless otherwise noted.

Table 3.

Parameter	Rating
V <sub>DD</sub> to GND	-0.3 V to +4 V
V <sub>DD</sub> to V <sub>DD</sub>	-0.3 V to +0.3 V
V <sub>P</sub> to GND	-0.3 V to +5.8 V
V <sub>P</sub> to V <sub>DD</sub>	-0.3 V to +5.8 V
Digital I/O Voltage to GND	-0.3 V to V <sub>DD</sub> + 0.3 V
Analog I/O Voltage to GND	-0.3 V to V <sub>DD</sub> + 0.3 V
REF <sub>IN</sub> , RF <sub>IN</sub> to GND	-0.3 V to V <sub>DD</sub> + 0.3 V
Operating Temperature Range	
Industrial (B Version)	-40°C to +85°C
Storage Temperature Range	-65°C to +150°C
Maximum Junction Temperature	150°C
TSSOP $\theta_{JA}$ Thermal Impedance	150.4°C/W
LFCSP $\theta_{JA}$ Thermal Impedance (Paddle Soldered)	122°C/W
LFCSP $\theta_{JA}$ Thermal Impedance (Paddle Not Soldered)	216°C/W
Lead Temperature, Soldering	
Vapor Phase (60 sec)	215°C
Infrared	220°C

<sup>1</sup> Stresses above those listed under Absolute Maximum Ratings may cause permanent damage to the device. This is a stress rating only; functional operation of the device at these or any other conditions above those listed in the operational sections of this specification is not implied. Exposure to absolute maximum rating conditions for extended periods may affect device reliability.

<sup>2</sup> This device is a high performance RF integrated circuit with an ESD rating of < 2 kV, and it is ESD sensitive. Proper precautions should be taken for handling and assembly.

<sup>3</sup> GND = AGND = DGND = 0 V.

<sup>4</sup> V<sub>DD</sub> = AV<sub>DD</sub> = DV<sub>DD</sub> = SDV<sub>DD</sub>.

## ESD CAUTION

ESD (electrostatic discharge) sensitive device. Electrostatic charges as high as 4000 V readily accumulate on the human body and test equipment and can discharge without detection. Although this product features proprietary ESD protection circuitry, permanent damage may occur on devices subjected to high energy electrostatic discharges. Therefore, proper ESD precautions are recommended to avoid performance degradation or loss of functionality.



## PIN CONFIGURATION AND PIN FUNCTION DESCRIPTIONS

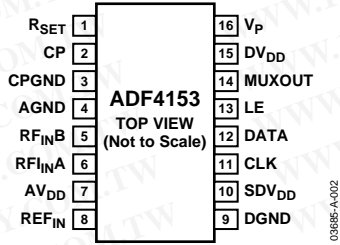

Figure 3. TSSOP Pin Configuration

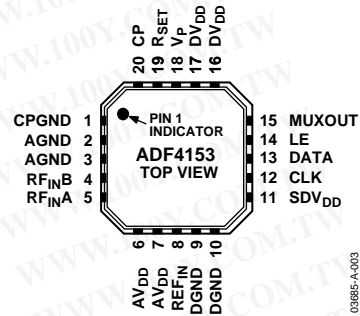

Figure 4. LFCSP Pin Configuration

Table 4. Pin Function Descriptions

TSSOP	LFCSP	Mnemonic	Description
1	19	R <sub>SET</sub>	Connecting a resistor between this pin and ground sets the maximum charge pump output current. The relationship between I <sub>CP</sub> and R <sub>SET</sub> is $I_{CP\max} = \frac{25.5}{R_{SET}}$ With R <sub>SET</sub> = 5.1 kΩ, I <sub>CP</sub> max = 5 mA.
2	20	CP	Charge Pump Output. When enabled, this provides ±I <sub>CP</sub> to the external loop filter, which in turn drives the external VCO.
3	1	CPGND	Charge Pump Ground. This is the ground return path for the charge pump.
4	2, 3	AGND	Analog Ground. This is the ground return path of the prescaler.
5	4	RF <sub>INB</sub>	Complementary Input to the RF Prescaler. This point should be decoupled to the ground plane with a small bypass capacitor, typically 100 pF (see Figure 17).
6	5	RF <sub>INA</sub>	Input to the RF Prescaler. This small-signal input is normally ac-coupled from the VCO.
7	6, 7	AV <sub>DD</sub>	Positive Power Supply for the RF Section. Decoupling capacitors to the digital ground plane should be placed as close as possible to this pin. AV <sub>DD</sub> has a value of 3 V ± 10%. AV <sub>DD</sub> must have the same voltage as DV <sub>DD</sub> .
8	8	REF <sub>IN</sub>	Reference Input. This is a CMOS input with a nominal threshold of V <sub>DD</sub> /2 and an equivalent input resistance of 100 kΩ (see Figure 16). This input can be driven from a TTL or CMOS crystal oscillator, or it can be ac-coupled.
9	9, 10	DGND	Digital Ground.
10	11	SDV <sub>DD</sub>	Σ-Δ Power. Decoupling capacitors to the digital ground plane should be placed as close as possible to this pin. SDV <sub>DD</sub> has a value of 3 V ± 10%. SDV <sub>DD</sub> must have the same voltage as DV <sub>DD</sub> .
11	12	CLK	Serial Clock Input. This serial clock is used to clock in the serial data to the registers. The data is latched into the shift register on the CLK rising edge. This input is a high impedance CMOS input.
12	13	DATA	Serial Data Input. The serial data is loaded MSB first with the two LSBs being the control bits. This input is a high impedance CMOS input.
13	14	LE	Load Enable, CMOS Input. When LE is high, the data stored in the shift registers is loaded into one of the four latches, the latch being selected using the control bits.
14	15	MUXOUT	This multiplexer output allows either the RF lock detect, the scaled RF, or the scaled reference frequency to be accessed externally.
15	16, 17	DV <sub>DD</sub>	Positive Power Supply for the Digital Section. Decoupling capacitors to the digital ground plane should be placed as close as possible to this pin. DV <sub>DD</sub> has a value of 3 V ± 10%. DV <sub>DD</sub> must have the same voltage as AV <sub>DD</sub> .
16	18	V <sub>P</sub>	Charge Pump Power Supply. This should be greater than or equal to V <sub>DD</sub> . In systems where V <sub>DD</sub> is 3 V, it can be set to 5.5 V and used to drive a VCO with a tuning range of up to 5.5 V.

# ADF4153

## TYPICAL PERFORMANCE CHARACTERISTICS

Figure 5 to Figure 10:  $R_{FOUT} = 1.722\text{ GHz}$ , PFD Freq = 26 MHz, INT = 66, Channel Spacing = 200 kHz, Modulus = 130, Fraction = 1/130, and  $I_{CP} = 5\text{ mA}$ .

Loop Bandwidth = 20 kHz, Reference = Fox 10 MHz TCXO, VCO = Vari-L VCO190-1750T, Eval Board = Eval-ADF4153EB1, measurements taken on HP8562E spectrum analyzer.

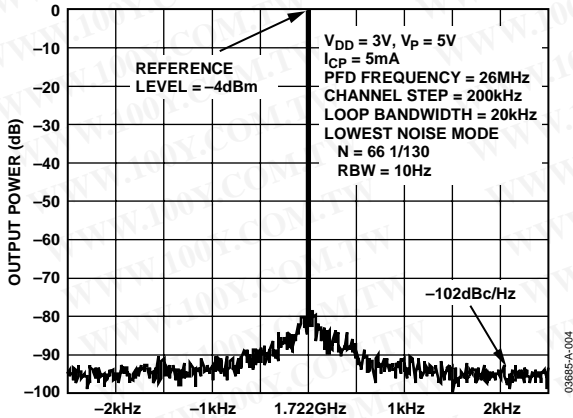

Figure 5. Phase Noise (Lowest Noise Mode)

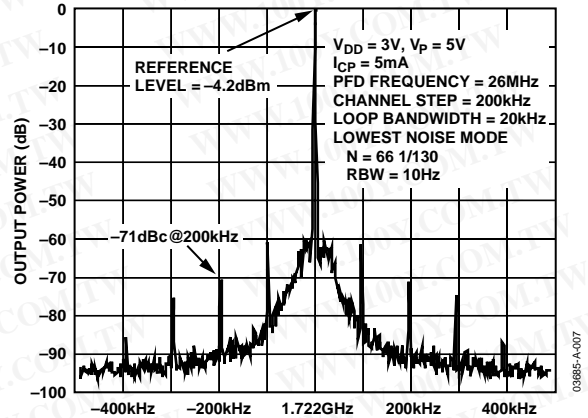

Figure 8. Spurs (Lowest Noise Mode)

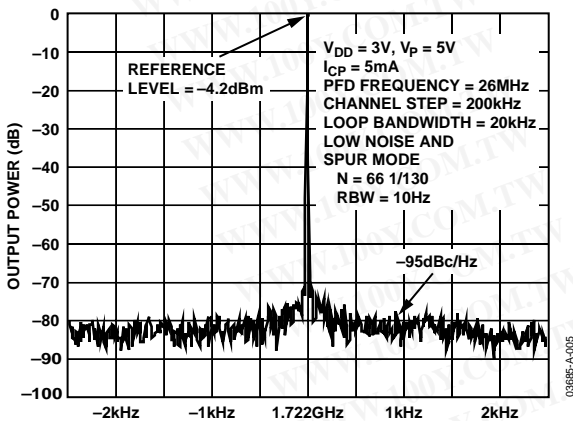

Figure 6. Phase Noise (Low Noise Mode and Spur Mode)

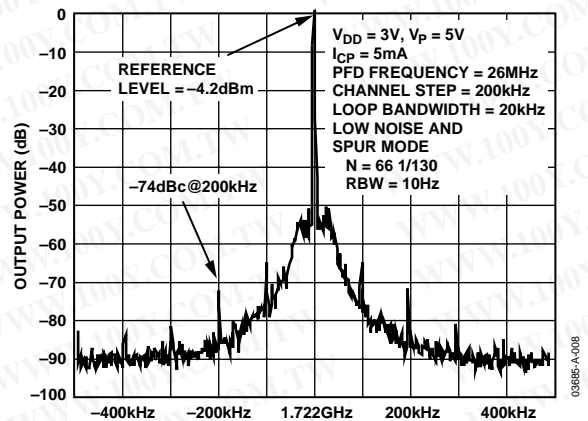

Figure 9. Spurs (Low Noise and Spur Mode)

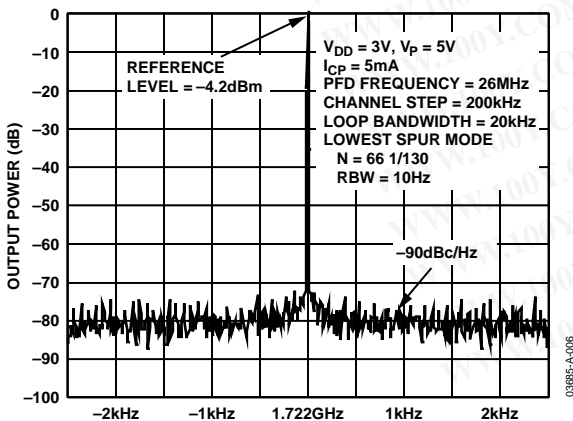

Figure 7. Phase Noise (Lowest Spur Mode)

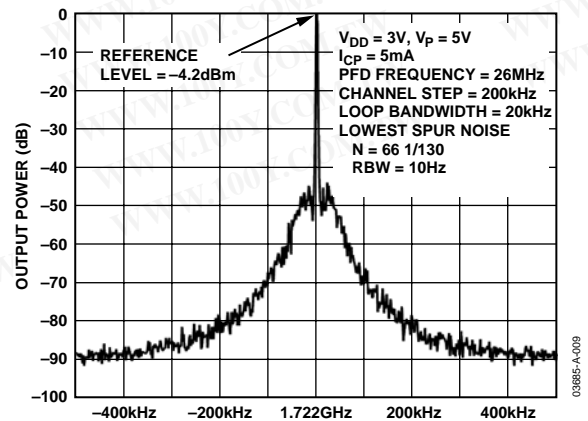

Figure 10. Spurs (Lowest Spur Mode)

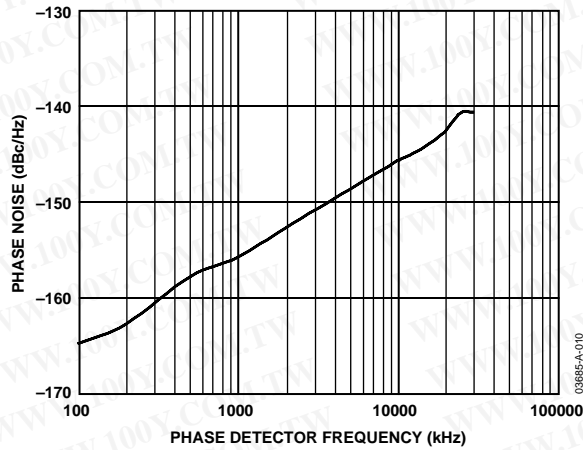

Figure 11. PFD Noise Floor vs. PFD Frequency (Lowest Noise Mode)

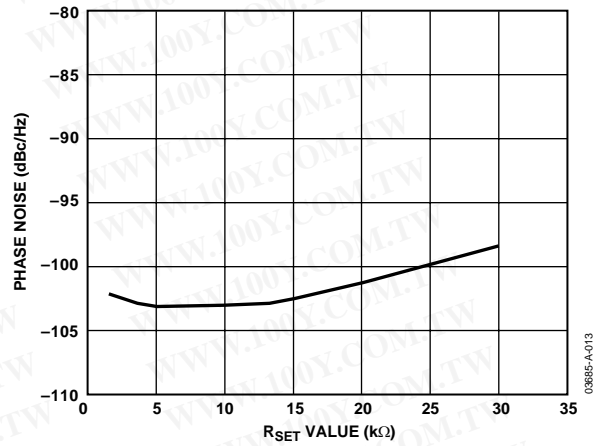

Figure 14. Phase Noise vs.  $R_{SET}$

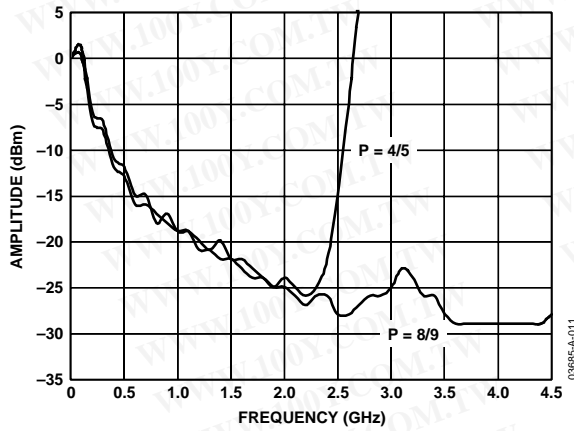

Figure 12. RF Input Sensitivity

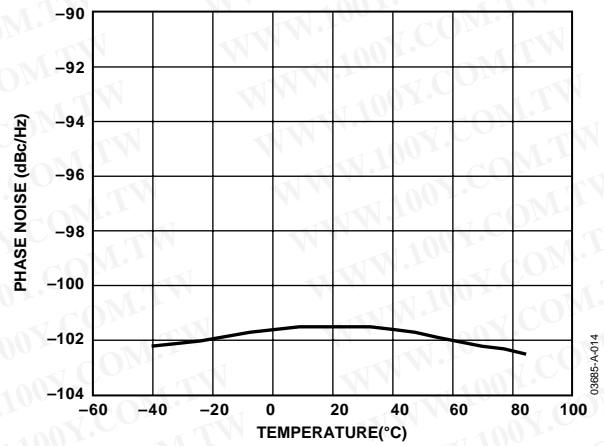

Figure 15. Phase Noise vs. Temperature

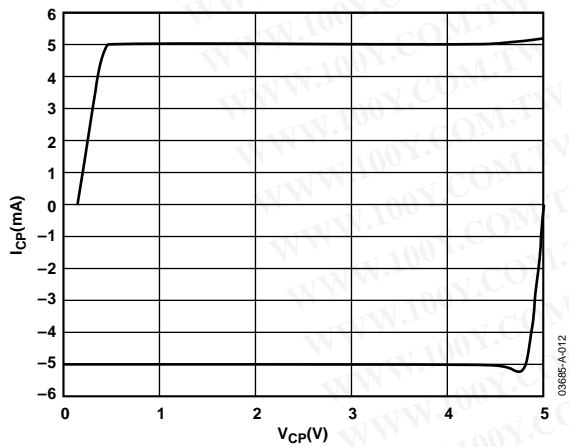

Figure 13. Charge Pump Output Characteristics

# ADF4153

## CIRCUIT DESCRIPTION

### REFERENCE INPUT SECTION

The reference input stage is shown in Figure 16. SW1 and SW2 are normally closed switches. SW3 is normally open. When power-down is initiated, SW3 is closed and SW1 and SW2 are opened. This ensures that there is no loading of the REF<sub>IN</sub> pin on power-down.

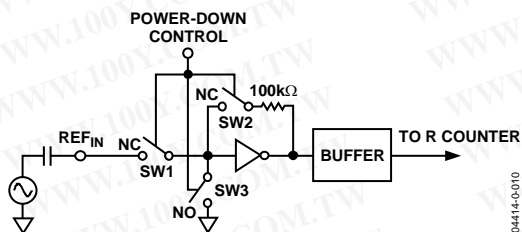

Figure 16. Reference Input Stage

### RF INPUT STAGE

The RF input stage is shown in Figure 17. It is followed by a 2-stage limiting amplifier to generate the current mode logic (CML) clock levels needed for the prescaler.

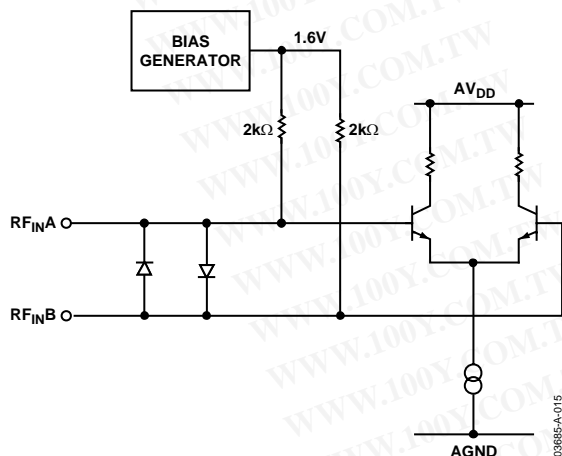

Figure 17. RF Input Stage

### RF INT DIVIDER

The RF INT CMOS counter allows a division ratio in the PLL feedback counter. Division ratios from 31 to 511 are allowed.

### INT, FRAC, MOD, AND R RELATIONSHIP

The INT, FRAC, and MOD values, in conjunction with the R counter, make it possible to generate output frequencies that are spaced by fractions of the phase frequency detector (PFD). See the RF Synthesizer: A Worked Example section for more information. The RF VCO frequency ( $RF_{OUT}$ ) equation is

$$RF_{OUT} = F_{PFD} \times (INT + (FRAC/MOD)) \tag{1}$$

where  $RF_{OUT}$  is the output frequency of external voltage controlled oscillator (VCO).

$$F_{PFD} = REF_{IN} \times (1 + D)/R \tag{2}$$

where:

$REF_{IN}$  is the reference input frequency.

$D$  is the REF<sub>IN</sub> doubler bit.

$R$  is the preset divide ratio of binary 4-bit programmable reference counter (1 to 15).

$INT$  is the preset divide ratio of binary 9-bit counter (31 to 511).

$MOD$  is the preset modulus ratio of binary 12-bit programmable FRAC counter (2 to 4095).

$FRAC$  is the preset fractional ratio of binary 12-bit programmable FRAC counter (0 to MOD).

### RF R COUNTER

The 4-bit RF R counter allows the input reference frequency ( $REF_{IN}$ ) to be divided down to produce the reference clock to the PFD. Division ratios from 1 to 15 are allowed.

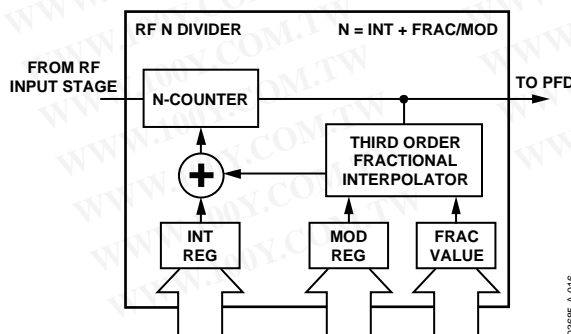

Figure 18. A and B Counters

## PHASE FREQUENCY DETECTOR (PFD) AND CHARGE PUMP

The PFD takes inputs from the R counter and N counter and produces an output proportional to the phase and frequency difference between them. Figure 19 is a simplified schematic. The PFD includes a fixed delay element that sets the width of the antibacklash pulse, which is typically 3 ns. This pulse ensures that there is no dead zone in the PFD transfer function, and gives a consistent reference spur level.

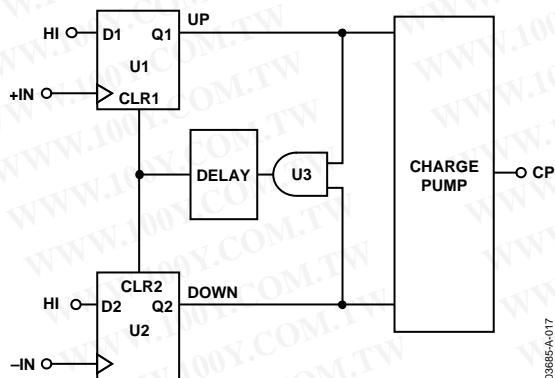

Figure 19. PFD Simplified Schematic

## MUXOUT AND LOCK DETECT

The output multiplexer on the ADF4153 allows the user to access various internal points on the chip. The state of MUXOUT is controlled by M3, M2, and M1 (see Table 8). Figure 20 shows the MUXOUT section in block diagram form.

The N-channel open-drain analog lock detect should be operated with an external pull-up resistor of 10 kΩ nominal. When lock has been detected, it is high with narrow low-going pulses.

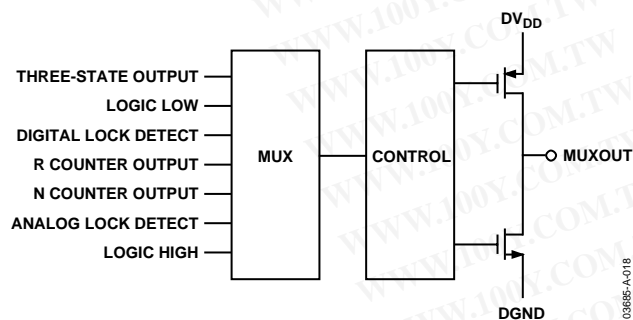

Figure 20. MUXOUT Schematic

## INPUT SHIFT REGISTERS

The ADF4153 digital section includes a 4-bit RF R counter, a 9-bit RF N counter, a 12-bit FRAC counter, and a 12-bit modulus counter. Data is clocked into the 24-bit shift register on each rising edge of CLK. The data is clocked in MSB first. Data is transferred from the shift register to one of four latches on the rising edge of LE. The destination latch is determined by the state of the two control bits (C2 and C1) in the shift register. These are the 2 LSBs, DB1 and DB0, as shown in Figure 2. The truth table for these bits is shown in Table 5. Table 6 shows a summary of how the latches are programmed.

## PROGRAM MODES

Table 5 through Table 10 show how to set up the program modes in the ADF4153.

The ADF4153 programmable modulus is double buffered. This means that two events have to occur before the part uses a new modulus value. First, the new modulus value is latched into the device by writing to the R divider register. Second, a new write must be performed on the N divider register. Therefore, any time that the modulus value has been updated, the N divider register must be written to after this, to ensure that the modulus value is loaded correctly.

Table 5. C2 and C1 Truth Table

Control Bits		Register
C2	C1	
0	0	N Divider Register
0	1	R Divider Register
1	0	Control Register
1	1	Noise and Spur Register

ADF4153

勝特力材料 886-3-5753170  
 勝特力电子(上海) 86-21-54151736  
 勝特力电子(深圳) 86-755-83298787  
 Http://www.100y.com.tw

Table 6. Register Summary

FASTLOCK		9-BIT INTEGER VALUE (INT)									12-BIT FRACTIONAL VALUE (FRAC)										CONTROL BITS		
DB23	DB22	DB21	DB20	DB19	DB18	DB17	DB16	DB15	DB14	DB13	DB12	DB11	DB10	DB9	DB8	DB7	DB6	DB5	DB4	DB3	DB2	DB1	DB0
FL1	N9	N8	N7	N6	N5	N4	N3	N2	N1	F12	F11	F10	F9	F8	F7	F6	F5	F4	F3	F2	F1	C2 (0)	C1 (0)

LOAD CONTROL		MUXOUT				RESERVED	PRESCALER	4-BIT R COUNTER				12-BIT INTERPOLATOR MODULUS VALUE (MOD)										CONTROL BITS	
DB23	DB22	DB21	DB20	DB19	DB18	DB17	DB16	DB15	DB14	DB13	DB12	DB11	DB10	DB9	DB8	DB7	DB6	DB5	DB4	DB3	DB2	DB1	DB0
P3	M3	M2	M1	P2	P1	R4	R3	R2	R1	M12	M11	M10	M9	M8	M7	M6	M5	M4	M3	M2	M1	C2 (0)	C1 (1)

RESYNC				REFERENCE DOUBLER	CP/2	CP CURRENT SETTING				PD POLARITY	LDP	POWER-DOWN	CP THREE-STATE	COUNTER RESET	CONTROL BITS	
DB15	DB14	DB13	DB12	DB11	DB10	DB9	DB8	DB7	DB6	DB5	DB4	DB3	DB2	DB1	DB0	
S4	S3	S2	S1	U6	CP3	CP2	CP1	CP0	U5	U4	U3	U2	U1	C2 (1)	C1 (0)	

RESERVED	NOISE AND SPUR MODE				RESERVED			NOISE AND SPUR MODE	CONTROL BITS	
DB10	DB9	DB8	DB7	DB6	DB5	DB4	DB3	DB2	DB1	DB0
T9	T8	T7	T6	T5	T4	T3	T2	T1	C2 (1)	C1 (1)

Table 7. N Divider Register Map

FAST LOCK	9-BIT INTEGER VALUE (INT)										12-BIT FRACTIONAL VALUE (FRAC)										CONTROL BITS		
	DB23	DB22	DB21	DB20	DB19	DB18	DB17	DB16	DB15	DB14	DB13	DB12	DB11	DB10	DB9	DB8	DB7	DB6	DB5	DB4	DB3	DB2	DB1
FL1	N9	N8	N7	N6	N5	N4	N3	N2	N1	F12	F11	F10	F9	F8	F7	F6	F5	F4	F3	F2	F1	C2 (0)	C1 (0)

F12	F11	F10	F9	F8	F7	F6	F5	F4	F3	F2	F1	FRACTIONAL VALUE (FRAC)
0	0	0	.....	0	0	0	0	0	0	0	0	0
0	0	0	.....	0	0	0	0	0	0	0	1	1
0	0	0	.....	0	0	0	0	0	0	1	0	2
0	0	0	.....	0	0	0	0	0	0	1	1	3
.	.	.	.....	.	.	.	.	.	.	.	.	.
.	.	.	.....	.	.	.	.	.	.	.	.	.
.	.	.	.....	.	.	.	.	.	.	.	.	.
1	1	1	.....	1	0	0	0	0	0	0	0	4092
1	1	1	.....	1	0	1	0	0	0	0	1	4093
1	1	1	.....	1	1	0	0	0	0	0	0	4094
1	1	1	.....	1	1	1	0	0	0	0	1	4095

N9	N8	N7	N6	N5	N4	N3	N2	N1	INTEGER VALUE (INT)
0	0	0	0	1	1	1	1	1	31
0	0	0	1	0	0	0	0	0	32
0	0	0	1	0	0	0	0	1	33
0	0	0	1	0	0	0	1	0	34
.	.	.	.	.	.	.	.	.	.
.	.	.	.	.	.	.	.	.	.
.	.	.	.	.	.	.	.	.	.
1	1	1	1	1	1	1	0	1	509
1	1	1	1	1	1	1	1	0	510
1	1	1	1	1	1	1	1	1	511

FL1	FASTLOCK
0	NORMAL OPERATION
1	FAST LOCK ENABLED

Table 8. R Divider Register Map

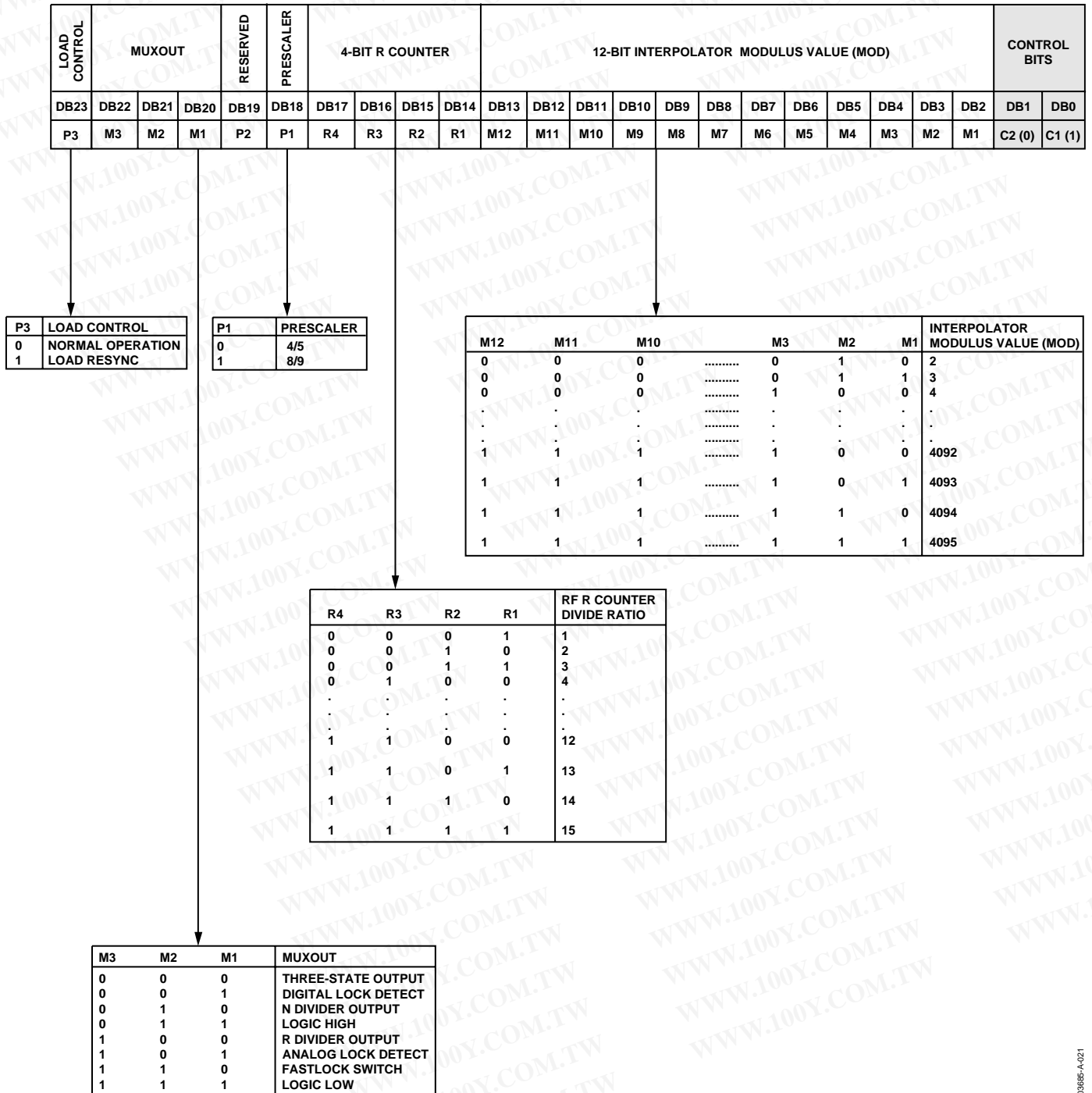
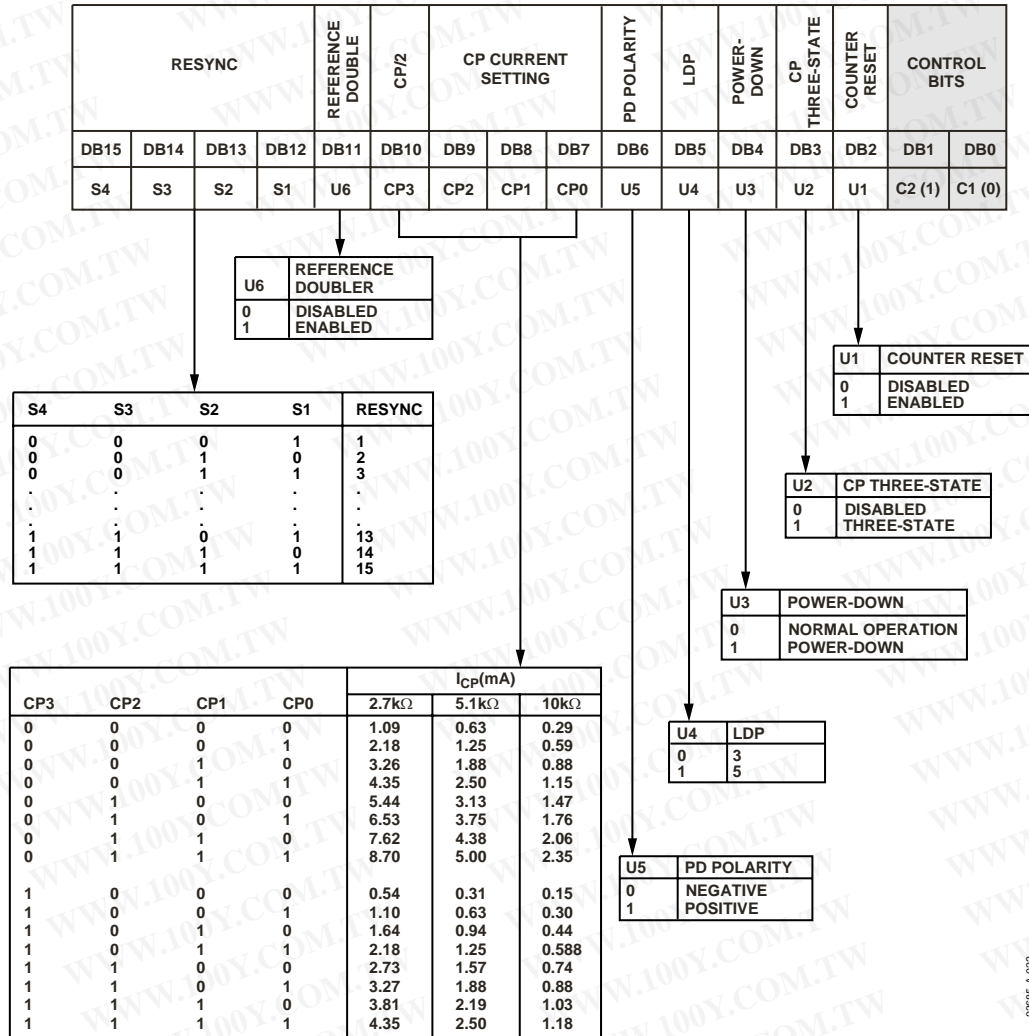

Table 9. Control Register Map



03865-A-022

# ADF4153

Table 10. Noise and Spur Register

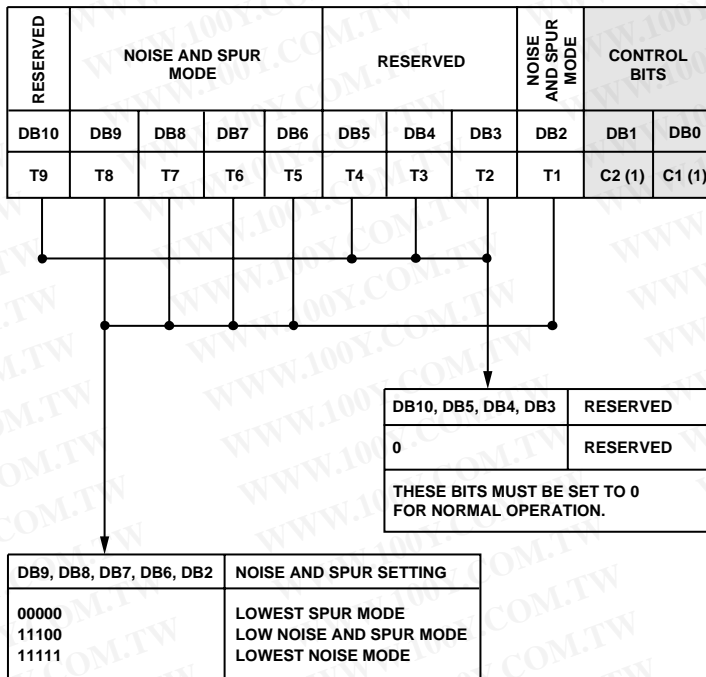

03865-A-023

## N DIVIDER REGISTER, R0

With R0[1, 0] set to [0, 0], the on-chip N divider register is programmed. Table 7 shows the input data format for programming this register.

### 9-Bit INT Value

These nine bits control what is loaded as the INT value. This is used to determine the overall feedback division factor. It is used in Equation 1.

### 12-Bit FRAC Value

These 12 bits control what is loaded as the FRAC value into the fractional interpolator. This is part of what determines the overall feedback division factor. It is used in Equation 1. The FRAC value must be less than or equal to the value loaded into the MOD register.

### Fastlock

When set to logic high, this enables the fastlock. This sets the charge pump current to its maximum value. When set to logic low, the charge pump current is equal to the value programmed in the function register.

## R DIVIDER REGISTER, R1

With R1[1, 0] set to [0, 1], the on-chip R divider register is programmed. Table 8 shows the input data format for programming this register.

### Load Control

When set to logic high, the value being programmed in the modulus is not loaded into the modulus. Instead, it sets the resync delay of the  $\Sigma$ - $\Delta$ . This is done to ensure phase resync when changing frequencies. See the Phase Resync and Spur Consistency section for more information and a worked example.

### MUXOUT

The on-chip multiplexer is controlled by R1[22 ... 20] on the ADF4153. Table 8 shows the truth table.

### Digital Lock Detect

The digital lock detect output goes high if there are 40 successive PFD cycles with an input error of less than 15 ns. It stays high until a new channel is programmed or until the error at the PFD input exceeds 30 ns for one or more cycles. If the loop bandwidth is narrow compared to the PFD frequency, the error at the PFD inputs may drop below 15 ns for 40 cycles around a cycle slip. Therefore, the digital lock detect may go falsely high for a short period until the error again exceeds 30 ns. In this case, the digital lock detect is reliable only as a loss-of-lock detector.

### Prescaler (P/P + 1)

The dual-modulus prescaler (P/P + 1), along with the INT, FRAC, and MOD counters, determines the overall division ratio from the RF<sub>IN</sub> to the PFD input. Operating at CML levels, it

takes the clock from the RF input stage and divides it down for the counters. It is based on a synchronous 4/5 core. When set to 4/5, the maximum RF frequency allowed is 2 GHz. Therefore, when operating the ADF4153 above 2 GHz, this must be set to 8/9. The prescaler limits the INT value.

With P = 4/5, N<sub>MIN</sub> = 31.

With P = 8/9, N<sub>MIN</sub> = 91.

The prescaler can also influence the phase noise performance. If INT < 91, a prescaler of 4/5 should be used. For applications where INT > 91, P = 8/9 should be used for optimum noise performance (see Table 8).

### 4-Bit RF R Counter

The 4-bit RF R counter allows the input reference frequency (REF<sub>IN</sub>) to be divided down to produce the reference clock to the phase frequency detector (PFD). Division ratios from 1 to 15 are allowed.

### 12-Bit Interpolator Modulus

This programmable register sets the fractional modulus. This is the ratio of the PFD frequency to the channel step resolution on the RF output. Refer to the RF Synthesizer: A Worked Example section for more information.

The ADF4153 programmable modulus is double buffered. This means that two events have to occur before the part uses a new modulus value. First, the new modulus value is latched into the device by writing to the R divider register. Second, a new write must be performed on the N divider register. Therefore, any time that the modulus value has been updated, the N divider register must be written to after this, to ensure that the modulus value is loaded correctly.

## CONTROL REGISTER, R2

With R2[1, 0] set to [0, 1], the on-chip control register is programmed. Table 9 shows the input data format for programming this register.

### RF Counter Reset

DB3 is the RF counter reset bit for the ADF4153. When this is 1, the RF synthesizer counters are held in reset. For normal operation, this bit should be 0.

### RF Charge Pump Three-State

This bit puts the charge pump into three-state mode when programmed to 1. It should be set to 0 for normal operation.

### RF Power-Down

DB4 on the ADF4153 provides the programmable power-down mode. Setting this bit to 1 performs a power-down. Setting this bit to 0 returns the synthesizer to normal operation. While in software power-down mode, the part retains all information in its registers. Only when supplies are removed are the register contents lost.

When a power-down is activated, the following events occur:

1. All active dc current paths are removed.
2. The synthesizer counters are forced to their load state conditions.
3. The charge pump is forced into three-state mode.
4. The digital lock detect circuitry is reset.
5. The  $RF_{IN}$  input is debiased.
6. The input register remains active and capable of loading and latching data.

#### Lock Detect Precision (LDP)

When this bit is programmed to 0, three consecutive reference cycles of 15 ns must occur before digital lock detect is set. When this bit is programmed to 1, five consecutive reference cycles of 15 ns must occur before digital lock detect is set.

#### Phase Detector Polarity

DB6 in the ADF4153 sets the phase detector polarity. When the VCO characteristics are positive, this should be set to 1. When they are negative, it should be set to 0.

#### Charge Pump Current Setting

DB7, DB8, and DB9 set the charge pump current setting. This should be set to the charge pump current that the loop filter is designed with (see Table 9).

#### $REF_{IN}$ Doubler

Setting this bit to 0 feeds the  $REF_{IN}$  signal directly to the 4-bit RF R counter, disabling the doubler. Setting this bit to 1 multiplies the  $REF_{IN}$  frequency by a factor of 2 before feeding into the 4-bit R counter. When the doubler is disabled, the  $REF_{IN}$  falling edge is the active edge at the PFD input to the fractional synthesizer. When the doubler is enabled, both the rising and falling edges of  $REF_{IN}$  become active edges at the PFD input.

When the doubler is enabled and the lowest spur mode is chosen, the in-band phase noise performance is sensitive to the  $REF_{IN}$  duty cycle. The phase noise degradation can be as much as 5 dB for the  $REF_{IN}$  duty cycles outside a 45% to 55% range. The phase noise is insensitive to the  $REF_{IN}$  duty cycle in the lowest noise mode and in the lowest noise and spur mode. The phase noise is insensitive to  $REF_{IN}$  duty cycle when the doubler is disabled.

### NOISE AND SPUR REGISTER, R3

With R3[1, 0] set to 1, 1, the on-chip noise and spur register is programmed. Table 10 shows the input data format for programming this register.

#### Noise and Spur Mode

Noise and spur mode allows the user to optimize a design either for improved spurious performance or for improved phase noise performance. When the lowest spur setting is chosen,

dither is enabled. This randomizes the fractional quantization noise so that it looks more like white noise rather than spurious noise. This means that the part is optimized for improved spurious performance. This operation would normally be used when the PLL closed-loop bandwidth is wide, for fast-locking applications. (Wide-loop bandwidth is seen as a loop bandwidth greater than 1/10 of the  $RF_{OUT}$  channel step resolution ( $f_{RES}$ )). A wide-loop filter does not attenuate the spurs to a level that a narrow-loop bandwidth would. When the low noise and spur setting is enabled, dither is disabled. This optimizes the synthesizer to operate with improved noise performance. However, the spurious performance is degraded in this mode compared to the lowest spurs setting. To further improve noise performance, the lowest noise setting option can be used, which reduces the phase noise. As well as disabling the dither, it also ensures that the charge pump is operating in an optimum region for noise performance. This setting is extremely useful where a narrow-loop filter bandwidth is available. The synthesizer ensures extremely low noise and the filter attenuates the spurs. The typical performance characteristics give the user an idea of the trade-off in a typical WCDMA setup for the different noise and spur settings.

#### RESERVED BITS

These bits should be set to 0 for normal operation.

#### RF SYNTHESIZER: A WORKED EXAMPLE

This equation governs how the synthesizer should be programmed.

$$RF_{OUT} = [INT + (FRAC/MOD)] \times [F_{PFD}] \quad (3)$$

where:

$RF_{OUT}$  is the RF frequency output.

$INT$  is the integer division factor.

$FRAC$  is the fractionality.

$MOD$  is the modulus.

$$F_{PFD} = [REF_{IN} \times (1 + D)] / R \quad (4)$$

where:

$REF_{IN}$  is the reference frequency input.

$D$  is the RF  $REF_{IN}$  doubler bit.

$R$  is the RF reference division factor.

Example: In a GSM 1800 system, where 1.8 GHz RF frequency output ( $RF_{OUT}$ ) is required, a 13 MHz reference frequency input ( $REF_{IN}$ ) is available and a 200 kHz channel resolution ( $f_{RES}$ ) is required on the RF output.

$$MOD = REF_{IN} / f_{RES}$$

$$MOD = 13 \text{ MHz} / 200 \text{ kHz} = 65$$

From Equation 4:

$$F_{PFD} = \lceil 13 \text{ MHz} \times (1 + 0) / 1 \rceil = 13 \text{ MHz} \quad (5)$$

$$1.8 \text{ G} = 13 \text{ MHz} \times (INT + FRAC/65) \geq$$

$$INT = 138; \geq FRAC = 30 \quad (6)$$

## MODULUS

The choice of modulus (MOD) depends on the reference signal ( $REF_{IN}$ ) available and the channel resolution ( $f_{RES}$ ) required at the RF output. For example, a GSM system with 13 MHz  $REF_{IN}$  would set the modulus to 65. This means that the RF output resolution ( $f_{RES}$ ) is the 200 kHz (13 MHz/65) necessary for GSM.

## REFERENCE DOUBLER AND REFERENCE DIVIDER

The reference doubler on-chip allows the input reference signal to be doubled. This is useful for increasing the PFD comparison frequency. Making the PFD frequency higher improves the noise performance of the system. Doubling the PFD frequency usually results in an improvement in noise performance of 3 dB. It is important to note that the PFD cannot be operated above 32 MHz due to a limitation in the speed of the  $\Sigma$ - $\Delta$  circuit of the N divider.

## 12-BIT PROGRAMMABLE MODULUS

Unlike most other fractional-N PLLs, the ADF4153 allows the user to program the modulus over a 12-bit range. This means that the user can set up the part in many different configurations for the application, when combined with the reference doubler and the 4-bit R counter.

For example, here is an application that requires 1.75 GHz RF and 200 kHz channel step resolution. The system has a 13 MHz reference signal.

One possible setup is feeding the 13 MHz directly to the PFD and programming the modulus to divide by 65. This would result in the required 200 kHz resolution.

Another possible setup is using the reference doubler to create 26 MHz from the 13 MHz input signal. This 26 MHz is then fed into the PFD. The modulus is now programmed to divide by 130. This also results in 200 kHz resolution and offers superior phase noise performance over the previous setup.

The programmable modulus is also very useful for multi-standard applications. If a dual-mode phone requires PDC and GSM 1800 standards, the programmable modulus is a huge

benefit. PDC requires 25 kHz channel step resolution, whereas GSM 1800 requires 200 kHz channel step resolution. A 13 MHz reference signal could be fed directly to the PFD. The modulus would be programmed to 520 when in PDC mode (13 MHz/520 = 25 kHz). The modulus would be reprogrammed to 65 for GSM 1800 operation (13 MHz/65 = 200 kHz). It is important that the PFD frequency remains constant (13 MHz). This allows the user to design one loop filter that can be used in both setups without running into stability issues. It is the ratio of the RF frequency to the PFD frequency that affects the loop design. Keeping this relationship constant, instead of changing the modulus factor, results in a stable filter.

## SPURIOUS OPTIMIZATION AND FASTLOCK

As mentioned earlier, the part can be optimized for spurious performance. However, in fast locking applications, the loop bandwidth needs to be wide, and therefore the filter does not provide much attenuation of the spurs. The programmable charge pump can be used to get around this issue. The filter is designed for a narrow-loop bandwidth so that steady-state spurious specifications are met. This is designed using the lowest charge pump current setting. To implement fastlock during a frequency jump, the charge pump current is set to the maximum setting for the duration of the jump. This has the effect of widening the loop bandwidth, which improves lock time. When the PLL has locked to the new frequency, the charge pump is again programmed to the lowest charge pump current setting. This narrows the loop bandwidth to its original cutoff frequency to allow better attenuation of the spurs than the wide-loop bandwidth.

## PHASE RESYNC AND SPUR CONSISTENCY

Setting the RESYNC bits [S4, S3, S2, and S1] enables the phase RESYNC feature. With a fractional denominator of MOD, a fractional-N PLL can settle with any one of  $(2 \times \pi) / MOD$  valid phase offsets with respect to the reference input. This is different from integer-N where the RF output always settles to the same static phase offset with respect to the input reference, which is zero ideally. This is not an issue in applications that require only a consistent frequency lock. When RESYNC is enabled, it also ensures that spur levels remain consistent when the PLL returns to a certain frequency. This is due to the fact that the RESYNC function resets the  $\Sigma$ - $\Delta$  modulator. RESYNC is enabled by setting the S4 to S1 bits in R2 to a nonzero value. When the S4 to S1 bits are 0, 0, 0, and 0, RESYNC is disabled.

For applications where a consistent phase relationship between the output and reference is required (i.e., digital beam forming), the ADF4153 can be used with the phase resync feature enabled. This ensures that if the user programs the PLL to jump from Frequency (and Phase) A to Frequency (and Phase) B and back again to Frequency A, the PLL returns to the original phase (Phase A).

## ADF4153

When enabled, it activates every time the user programs Register R0 to set a new output frequency. However, if a cycle slip occurs in the settling transient after the phase RESYNC operation, the phase RESYNC is lost. This can be avoided by delaying the RESYNC activation until the locking transient is close to its final frequency. This is done by rewriting to R1 after R1 has been set up as normal. Setting load control [DB23] allows this. When set, instead of determining the fractional denominator, the MOD bits [M12 to M1] are used to set a time interval from when the new channel is programmed to the time the RESYNC is activated. This is called the delay. Its value should be programmed to set a time interval that is at least as long as the RF PLL lock time.

For example, if  $REF_{IN} = 26$  MHz and  $MOD = 130$  to give 200 kHz output steps ( $f_{RES}$ ), and the RF loop has a settling time of 150  $\mu$ s, then delay should be programmed to 3,900, as  $26 \text{ MHz} \times 150 \mu\text{s} = 3,900$ .

If the application requires the delay to be greater than 4095, the RESYNC bits should be increased. For example, if the lock time above is 1.5 ms, the delay should be programmed to  $26 \text{ MHz} \times 1.5 \text{ ms} = 39,000$ . In this case, program M12 to M1 to 3,900 and program S4 to S1 to 10. The delay is  $3,900 \times 10 = 39,000$ .

### SPURIOUS SIGNALS—PREDICTING WHERE THEY WILL APPEAR

Just as in integer-N PLLs, spurs appear at PFD frequency offsets from the carrier. In a fractional-N PLL, spurs also appear at frequencies equal to the  $RF_{OUT}$  channel step resolution ( $f_{RES}$ ). The third-order fractional interpolator engine of the ADF4153 may also introduce subfractional spurs. If the fractional denominator (MOD) is divisible by 2, spurs appear at  $1/2 f_{RES}$ . If the fractional denominator (MOD) is divisible by 3, spurs appear at  $1/3 f_{RES}$ . Harmonics of all spurs mentioned will also appear. With the lowest spur mode enabled, the fractional and subfractional spurs is attenuated dramatically. The worst-case spurs appear when the fraction is programmed to  $(1/MOD)$ . For example, in a GSM 900 MHz system with a 26 MHz PFD frequency and an  $RF_{OUT}$  channel step resolution ( $f_{RES}$ ) of 200 kHz, the  $MOD = 130$ . PFD spurs appear at 26 MHz offset, and fractional spurs appear at 200 kHz offset. Since MOD is divisible by 2, subfractional spurs are also present at 100 kHz offset.

### FILTER DESIGN—ADISIMPLL

A filter design and analysis program is available to help the user to implement PLL design. Visit [www.analog.com/pll](http://www.analog.com/pll) for a free download of the ADISimPLL software. The software designs, simulates, and analyzes the entire PLL frequency domain and time domain response. Various passive and active filter architectures are allowed. REV. #2 of ADISimPLL allows analysis of the ADF4153.

## INTERFACING

The ADF4153 has a simple SPI® compatible serial interface for writing to the device. SCLK, SDATA, and LE control the data transfer. When LE (latch enable) is high, the 22 bits that have been clocked into the input register on each rising edge of SCLK are transferred to the appropriate latch. See Figure 2 for the timing diagram and Table 5 for the latch truth table.

The maximum allowable serial clock rate is 20 MHz. This means that the maximum update rate possible for the device is 909 kHz or one update every 1.1  $\mu$ s. This is more than adequate for systems that have typical lock times in the hundreds of microseconds.

### ADuC812 Interface

Figure 21 shows the interface between the ADF4153 and the ADuC812 MicroConverter®. Since the ADuC812 is based on an 8051 core, this interface can be used with any 8051-based microcontroller. The MicroConverter is set up for SPI master mode with  $CPHA = 0$ . To initiate the operation, the I/O port driving LE is brought low. Each latch of the ADF4153 needs a 24-bit word, which is accomplished by writing three 8-bit bytes from the MicroConverter to the device. After the third byte is written, the LE input should be brought high to complete the transfer.

When operating in the mode described, the maximum SCLOCK rate of the ADuC812 is 4 MHz. This means that the maximum rate at which the output frequency can be changed is 180 kHz.

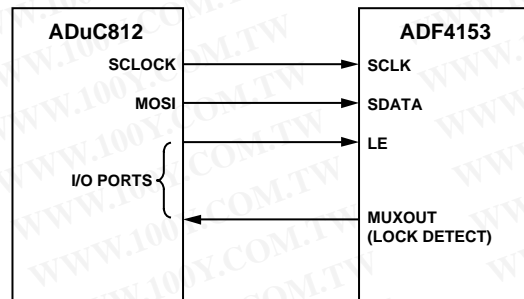

Figure 21. ADuC812 to ADF4153 Interface

### ADSP-2181 Interface

Figure 22 shows the interface between the ADF4153 and the ADSP-21xx digital signal processor. As discussed previously, the ADF4153 needs a 24-bit serial word for each latch write. The easiest way to accomplish this using the ADSP-21xx family is to use the autobuffered transmit mode of operation with alternate framing. This provides a means for transmitting an entire block of serial data before an interrupt is generated. Set up the word length for eight bits and use three memory locations for each 24-bit word. To program each 24-bit latch, store the three 8-bit bytes, enable the autobuffered mode, and write to the transmit register of the DSP. This last operation initiates the autobuffer transfer.

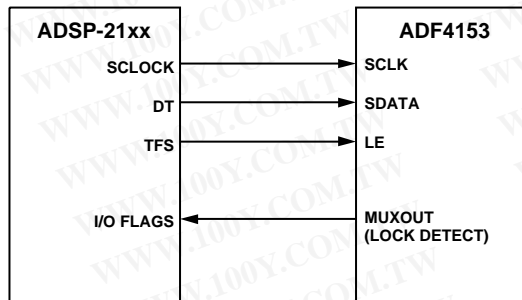

Figure 22. ADSP-21xx to ADF4153 Interface

### PCB DESIGN GUIDELINES FOR CHIP SCALE PACKAGE

The lands on the chip scale package (CP-20) are rectangular. The printed circuit board pad for these should be 0.1 mm longer than the package land length and 0.05 mm wider than the package land width. The land should be centered on the pad. This ensures that the solder joint size is maximized.

The bottom of the chip scale package has a central thermal pad. The thermal pad on the printed circuit board should be at least as large as this exposed pad. On the printed circuit board, there should be a clearance of at least 0.25 mm between the thermal pad and the inner edges of the pad pattern. This ensures that shorting is avoided.

Thermal vias may be used on the printed circuit board thermal pad to improve thermal performance of the package. If vias are used, they should be incorporated in the thermal pad at 1.2 mm pitch grid. The via diameter should be between 0.3 mm and 0.33 mm, and the via barrel should be plated with 1 oz. copper to plug the via.

The user should connect the printed circuit board thermal pad to AGND.

