

勝特力材料 886-3-5753170
 勝特力电子(上海) 86-21-54151736
 勝特力电子(深圳) 86-755-83298787
 Http://www.100y.com.tw

3141 THRU 3144

SENSITIVE HALL-EFFECT SWITCHES FOR HIGH-TEMPERATURE OPERATION

These Hall-effect switches are monolithic integrated circuits with tighter magnetic specifications, designed to operate continuously over extended temperatures to +150°C, and are more stable with both temperature and supply voltage changes. The unipolar switching characteristic makes these devices ideal for use with a simple bar or rod magnet. The four basic devices (3141, 3142, 3143, and 3144) are identical except for magnetic switch points.

Each device includes a voltage regulator for operation with supply voltages of 4.5 to 24 volts, reverse battery protection diode, quadratic Hall-voltage generator, temperature compensation circuitry, small-signal amplifier, Schmitt trigger, and an open-collector output to sink up to 25 mA. With suitable output pull up, they can be used with bipolar or CMOS logic circuits. The A3141- and A3142- are improved replacements for the UGN/UGS3140-; the A3144- is the improved replacement for the UGN/UGS3120-.

The first character of the part number suffix determines the device operating temperature range. Suffix 'E-' is for the automotive and industrial temperature range of -40°C to +85°C. Suffix 'L-' is for the automotive and military temperature range of -40°C to +150°C. Three package styles provide a magnetically optimized package for most applications. Suffix '-LT' is a miniature SOT-89/TO-243AA transistor package for surface-mount applications; suffix '-U' is a three-lead plastic mini-SIP, while suffix '-UA' is a three-lead ultra-mini-SIP.

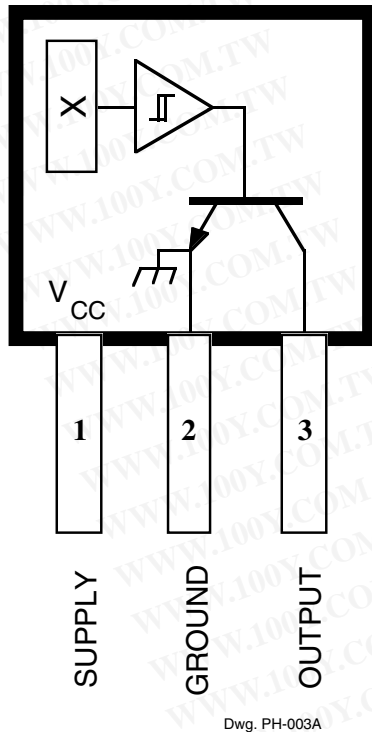

Pinning is shown viewed from branded side.

ABSOLUTE MAXIMUM RATINGS at $T_A = +25^\circ\text{C}$

Supply Voltage, V_{CC}	28 V
Reverse Battery Voltage, V_{RCC}	-35 V
Magnetic Flux Density, B	Unlimited
Output OFF Voltage, V_{OUT}	28 V
Reverse Output Voltage, V_{OUT}	-0.5 V
Continuous Output Current, I_{OUT}	25 mA
Operating Temperature Range, T_A	
Suffix 'E-'	-40°C to +85°C
Suffix 'L-'	-40°C to +150°C
Storage Temperature Range, T_S	-65°C to +170°C

FEATURES and BENEFITS

- Superior Temp. Stability for Automotive or Industrial Applications
- 4.5 V to 24 V Operation ... Needs Only An Unregulated Supply
- Open-Collector 25 mA Output ... Compatible with Digital Logic
- Reverse Battery Protection
- Activate with Small, Commercially Available Permanent Magnets
- Solid-State Reliability
- Small Size
- Resistant to Physical Stress

Always order by complete part number, e.g., **A3141ELT**.

3141 THRU 3144
SENSITIVE
HALL-EFFECT SWITCHES
FOR HIGH-TEMP. OPERATION

勝特力材料 886-3-5753170
 勝特力电子(上海) 86-21-54151736
 勝特力电子(深圳) 86-755-83298787
 Http://www.100y.com.tw

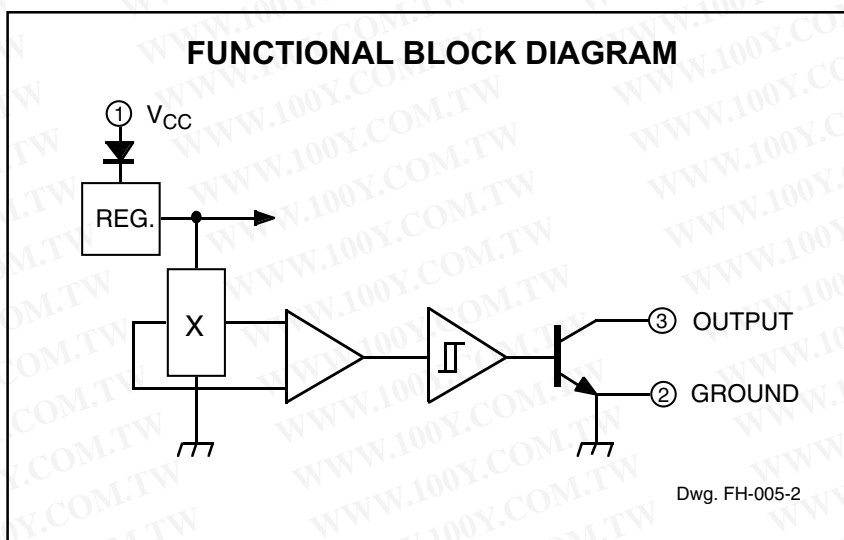

ELECTRICAL CHARACTERISTICS at $V_{CC} = 8\text{ V}$ over operating temperature range.

Characteristic	Symbol	Test Conditions	Limits			
			Min.	Typ.	Max.	Units
Supply Voltage	V_{CC}	Operating	4.5	—	24	V
Output Saturation Voltage	$V_{OUT(SAT)}$	$I_{OUT} = 20\text{ mA}$, $B > B_{OP}$	—	175	400	mV
Output Leakage Current	I_{OFF}	$V_{OUT} = 24\text{ V}$, $B < B_{RP}$	—	<1.0	10	μA
Supply Current	I_{CC}	$B < B_{RP}$ (Output OFF)	—	4.4	9.0	mA
Output Rise Time	t_r	$R_L = 820\ \Omega$, $C_L = 20\text{ pF}$	—	0.04	2.0	μs
Output Fall Time	t_f	$R_L = 820\ \Omega$, $C_L = 20\text{ pF}$	—	0.18	2.0	μs

MAGNETIC CHARACTERISTICS in gauss over operating supply voltage range.

Characteristic	Part Numbers*											
	A3141-			A3142-			A3143-			A3144-		
	Min.	Typ.	Max.	Min.	Typ.	Max.	Min.	Typ.	Max.	Min.	Typ.	Max.
B_{OP} at $T_A = 25^\circ\text{C}$	50	100	160	130	180	230	220	280	340	70	—	350
over operating temp. range	30	100	175	115	180	245	205	280	355	35	—	450
B_{RP} at $T_A = 25^\circ\text{C}$	10	45	130	75	125	175	165	225	285	50	—	330
over operating temp. range	10	45	145	60	125	190	150	225	300	25	—	430
B_{hys} at $T_A = 25^\circ\text{C}$	20	55	80	30	55	80	30	55	80	20	55	—
over operating temp. range	20	55	80	30	55	80	30	55	80	20	55	—

NOTES: Typical values are at $T_A = +25^\circ\text{C}$ and $V_{CC} = 8\text{ V}$.

B_{OP} = operate point (output turns ON); B_{RP} = release point (output turns OFF); B_{hys} = hysteresis ($B_{OP} - B_{RP}$).

*Complete part number includes a suffix to identify operating temperature range (E- or L-) and package type (-LT, -U, or -UA).



勝特力材料 886-3-5753170
 勝特力电子(上海) 86-21-54151736
 勝特力电子(深圳) 86-755-83298787
 Http://www.100y.com.tw

3141 THRU 3144 SENSITIVE HALL-EFFECT SWITCHES FOR HIGH-TEMP. OPERATION

TYPICAL OPERATING CHARACTERISTICS

A3142- SWITCH POINTS

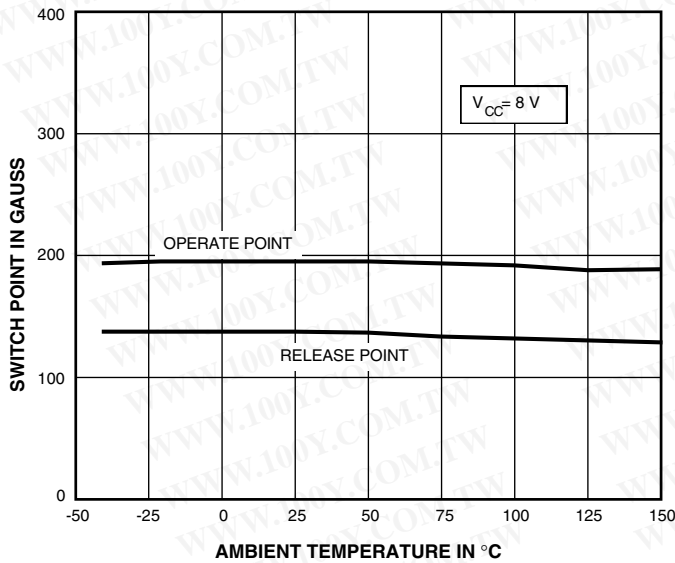

Dwg. GH-044

OUTPUT SATURATION VOLTAGE

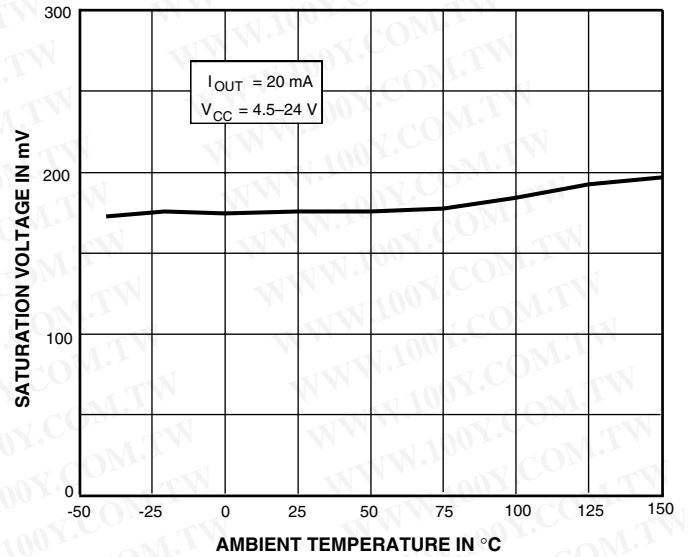

Dwg. GH-040-1

SUPPLY CURRENT

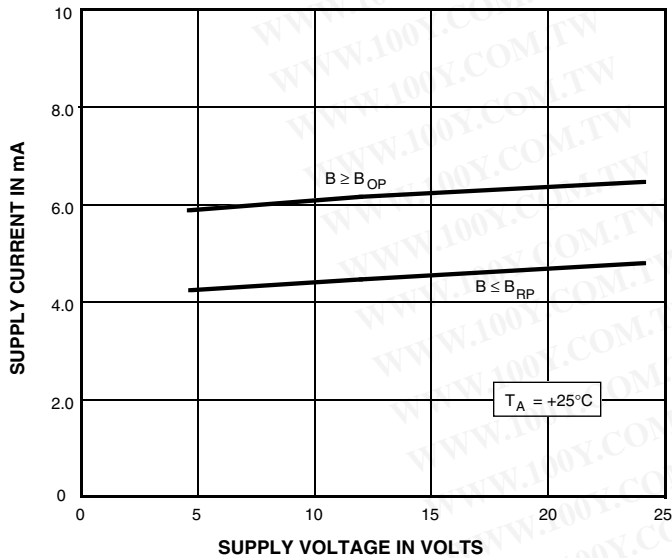

Dwg. GH-041-1

SUPPLY CURRENT

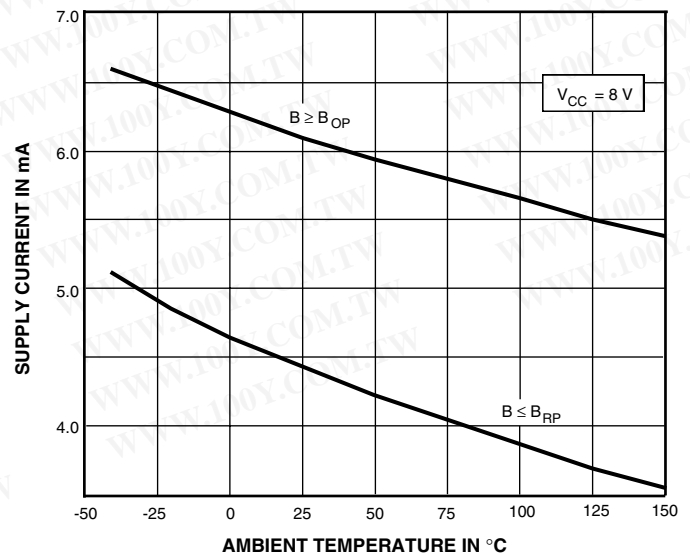

Dwg. GH-039-1

* Complete part number includes a suffix denoting operating temperature range (E- or L-) and package type (-LT, -U, or -UA).

3141 THRU 3144
SENSITIVE
HALL-EFFECT SWITCHES
FOR HIGH-TEMP. OPERATION

勝特力材料 886-3-5753170
 勝特力电子(上海) 86-21-54151736
 勝特力电子(深圳) 86-755-83298787
 Http://www.100y.com.tw

SENSOR LOCATIONS
 ($\pm 0.005''$ [0.13 mm] die placement)

Suffix "LT"

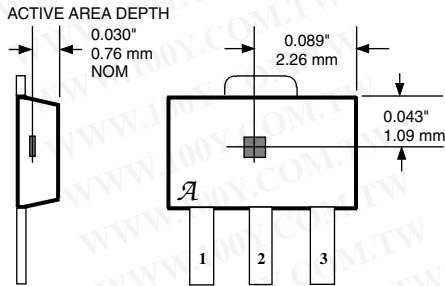

Dwg. MH-008-2C

Suffix "U"

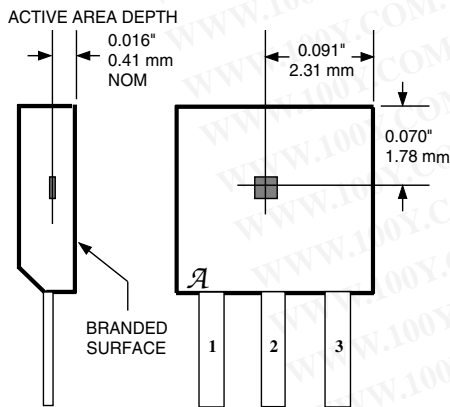

Dwg. MH-002-2B

Suffix "UA"

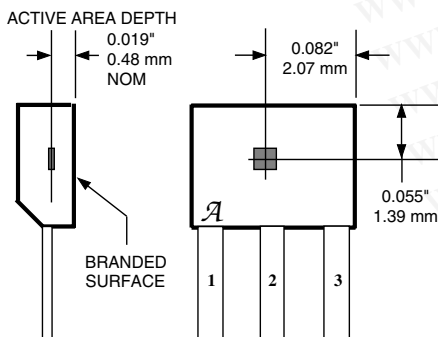

Dwg. MH-011-10

TYPICAL OPERATING CHARACTERISTICS (cont.)

CHANGE IN OPERATE POINT

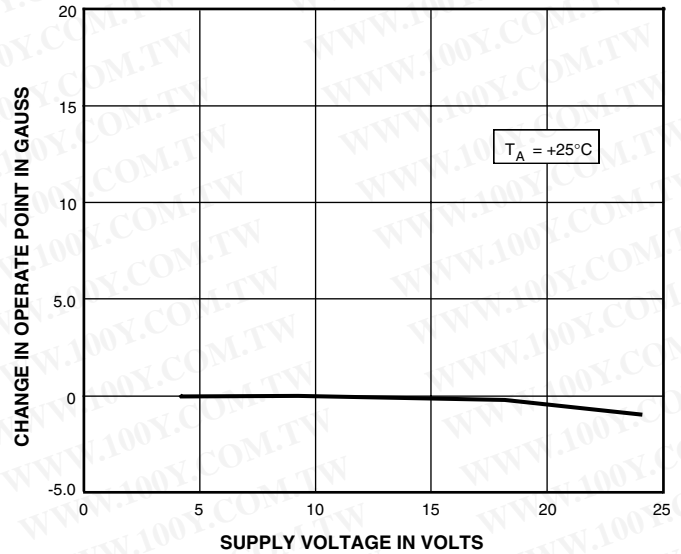

Dwg. GH-042-1

OPERATION

The output of these devices (pin 3) switches low when the magnetic field at the Hall sensor exceeds the operate point threshold (B_{OP}). At this point, the output voltage is $V_{OUT(SAT)}$. When the magnetic field is reduced to below the release point threshold (B_{RP}), the device output goes high. The difference in the magnetic operate and release points is called the hysteresis (B_{hys}) of the device. This built-in hysteresis allows clean switching of the output even in the presence of external mechanical vibration and electrical noise.

勝特力材料 886-3-5753170
 勝特力电子(上海) 86-21-54151736
 勝特力电子(深圳) 86-755-83298787
[Http://www.100y.com.tw](http://www.100y.com.tw)

3141 THRU 3144
SENSITIVE
HALL-EFFECT SWITCHES
FOR HIGH-TEMP. OPERATION

PACKAGE DESIGNATOR 'LT'
 (SOT-89/TO-243AA)

Dimensions in Inches
 (for reference only)

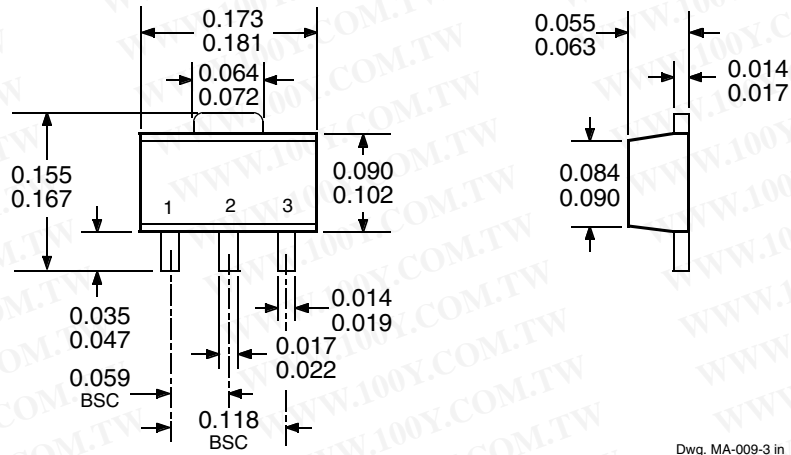

Dwg. MA-009-3 in

Dimensions in Millimeters
 (controlling dimensions)

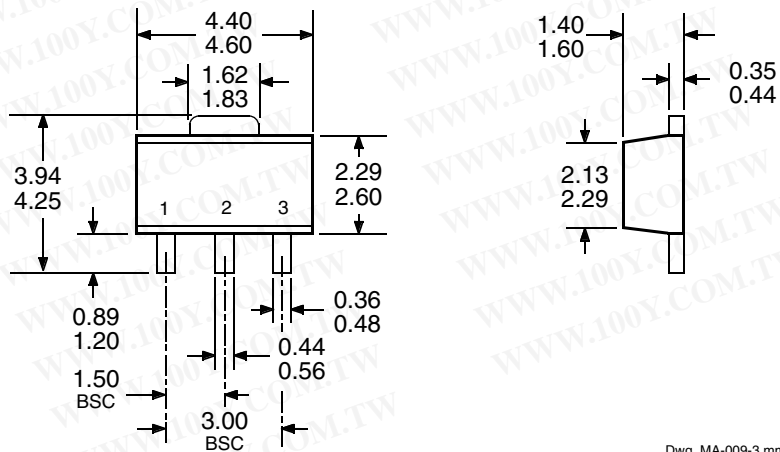

Dwg. MA-009-3 mm

- NOTES: 1. Tolerances on package height and width represent allowable mold offsets. Dimensions given are measured at the widest point (parting line).
2. Exact body and lead configuration at vendor's option within limits shown.
3. Height does not include mold gate flash.

3141 THRU 3144
SENSITIVE
HALL-EFFECT SWITCHES
FOR HIGH-TEMP. OPERATION

勝特力材料 886-3-5753170
 勝特力电子(上海) 86-21-54151736
 勝特力电子(深圳) 86-755-83298787
[Http://www.100y.com.tw](http://www.100y.com.tw)

PACKAGE DESIGNATOR 'U'

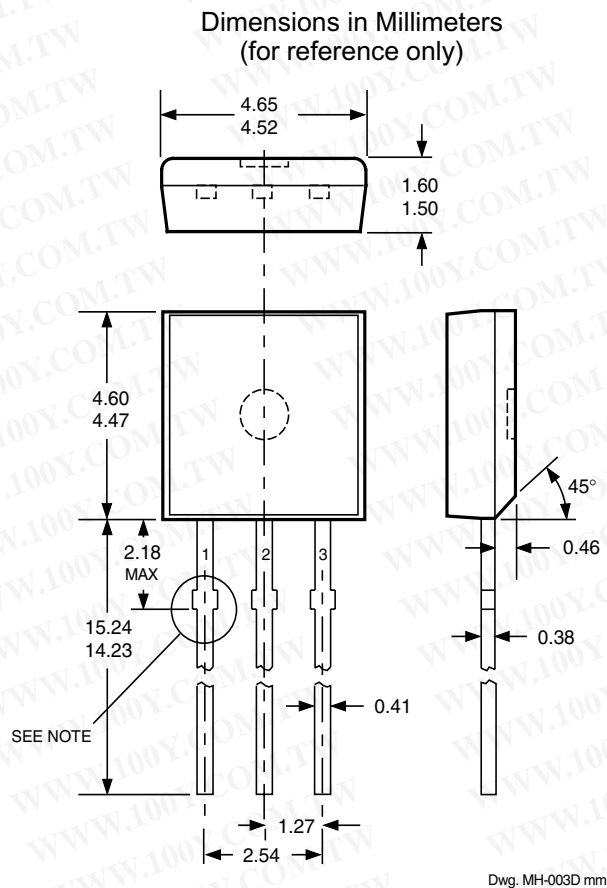
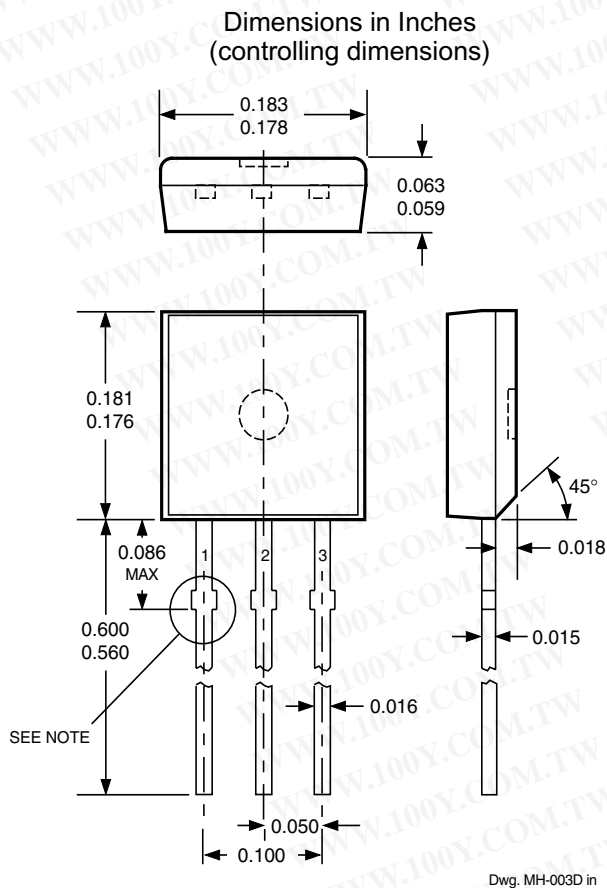

**Devices in the 'U' package are
 NOT RECOMMENDED FOR NEW DESIGN**

- NOTES: 1. Tolerances on package height and width represent allowable mold offsets. Dimensions given are measured at the widest point (parting line).
2. Exact body and lead configuration at vendor's option within limits shown.
3. Height does not include mold gate flash.
4. Recommended minimum PWB hole diameter to clear transition area is 0.035" (0.89 mm).

勝特力材料 886-3-5753170
 勝特力电子(上海) 86-21-54151736
 勝特力电子(深圳) 86-755-83298787
 Http://www.100y.com.tw

3141 THRU 3144
SENSITIVE
HALL-EFFECT SWITCHES
FOR HIGH-TEMP. OPERATION

PACKAGE DESIGNATOR 'UA'

Dimensions in Inches
(controlling dimensions)

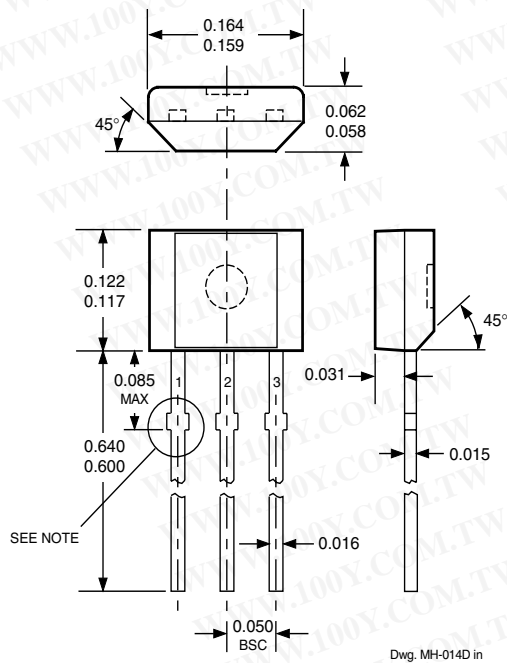

Dimensions in Millimeters
(for reference only)

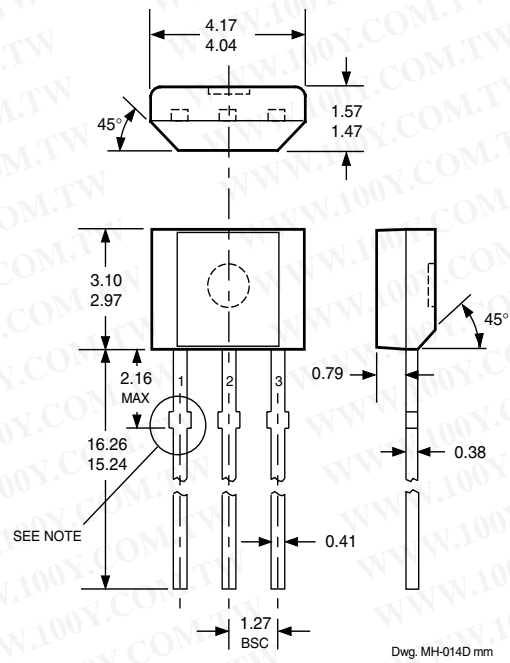

- NOTES: 1. Tolerances on package height and width represent allowable mold offsets. Dimensions given are measured at the widest point (parting line).
2. Exact body and lead configuration at vendor's option within limits shown.
3. Height does not include mold gate flash.

Allegro MicroSystems, Inc. reserves the right to make, from time to time, such departures from the detail specifications as may be required to permit improvements in the design of its products.

The information included herein is believed to be accurate and reliable. However, Allegro MicroSystems, Inc. assumes no responsibility for its use; nor for any infringements of patents or other rights of third parties which may result from its use.

3141 THRU 3144
SENSITIVE
HALL-EFFECT SWITCHES
FOR HIGH-TEMP. OPERATION

勝特力材料 886-3-5753170
 勝特力电子(上海) 86-21-54151736
 勝特力电子(深圳) 86-755-83298787
 Http://www.100y.com.tw

HALL-EFFECT SENSORS SELECTION GUIDE

Partial Part Number	Avail. Oper. Temp.	Characteristics at T _A = +25°C			Features	Notes
		B _{OP} (max)	B _{RP} (min)	B _{hys} (typ)		
HALL-EFFECT UNIPOLAR SWITCHES in order of B_{OP} and B_{hys}						
3240	E/L	+50	+5.0	10	chopper stabilized	1
3210	E	±70	±5.0	7.7	micropower, chopper stabilized	
3361	E	+120	+50	5.0*	2-wire, chopper stabilized	
3362	E	+120	+50	5.0*	2-wire, chopper stabilized	
3161	E	+160	+30	20	2-wire	
3141	E/L	+160	+10	55		
3235	S	+175	+25	15*	output 1	2
		-25	-175	15*	output 2	2
5140	E	+200	+50	55	300 mA output	1, 3
3142	E/L	+230	+75	55		
3143	E/L	+340	+165	55		
3144	E/L	+350	+50	55		
3122	E/L	+400	+140	105		
3123	E/L	+440	+180	105		
3121	E/L	+450	+125	105		
3150	J	+40 to +850	-	20	programmable, chopper stabilized	1
HALL-EFFECT LATCHES & BIPOLAR SWITCHES[†] in order of B_{OP} and B_{hys}						
3260	E/L	+30	-30	20	bipolar, chopper stabilized	
3280	E/L	+40	-40	45	chopper stabilized	
3134	E/L	+50	-50	27	bipolar switch	
3133	K/L/S	+75	-75	52	bipolar switch	
3281	E/L	+90	-90	100	chopper stabilized	
3132	K/L/S	+95	-95	52	bipolar switch	
3187	E/L	+150	-150	100*		
3177	S	+150	-150	200		
3625	S	+150	-150	200	900 mA outputs	1, 3, 5
3626	S	+150	-150	200	400 mA outputs	1, 3, 5
3195	E/L	+160	-160	220		1, 4
3197	L	+160	-160	230		1
3175	S	+170	-170	200		
3188	E/L	+180	-180	200*		
3283	E/L	+180	-180	300	chopper stabilized	
3189	E/L	+230	-230	100*		
3275	S	+250	-250	100*		5
3185	E/L	+270	-270	340*		

Operating Temperature Ranges:

S = -20°C to +85°C, E = -40°C to +85°C, J = -40°C to +115°C, K = -40°C to +125°C, L = -40°C to +150°C

Notes 1. Protected.

2. Output 1 switches on south pole, output 2 switches on north pole for 2-phase, bifilar-wound, unipolar-driven brushless dc motor control.

3. Power driver output.

4. Active pull down.

5. Complementary outputs for 2-phase bifilar-wound, unipolar-driven brushless dc motor control.

* Minimum.

† Latches will not switch on removal of magnetic field; bipolar switches may switch on removal of field but require field reversal for reliable operation over operating temperature range.