

## FEATURES

- *Guaranteed* Filter Specification for  $\pm 2.37V$  and  $\pm 5V$  Supply
- Operates Up to 30kHz
- Low Power and 88dB Dynamic Range at  $\pm 2.5V$  Supply
- Center Frequency Q Product Up to 1.6MHz
- *Guaranteed* Offset Voltages
- *Guaranteed* Clock-to-Center Frequency Accuracy Over Temperature:
  - 0.3% for LTC1060A
  - 0.8% for LTC1060
- *Guaranteed* Q Accuracy Over Temperature
- Low Temperature Coefficient of Q and Center Frequency
- Low Crosstalk, 70dB
- Clock Inputs TTL and CMOS Compatible

## APPLICATIONS

- Single 5V Supply Medium Frequency Filters
- Very High Q and High Dynamic Range Bandpass, Notch Filters
- Tracking Filters
- Telecom Filters

## DESCRIPTION

The LTC<sup>®</sup>1060 consists of two high performance, switched capacitor filters. Each filter, together with 2 to 5 resistors, can produce various 2nd order filter functions such as lowpass, bandpass, highpass notch and allpass. The center frequency of these functions can be tuned by an external clock or by an external clock and resistor ratio. Up to 4th order full biquadratic functions can be achieved by cascading the two filter blocks. Any of the classical filter configurations (like Butterworth, Chebyshev, Bessel, Cauer) can be formed.

The LTC1060 operates with either a single or dual supply from  $\pm 2.37V$  to  $\pm 8V$ . When used with low supply (i.e. single 5V supply), the filter typically consumes 12mW and can operate with center frequencies up to 10kHz. With  $\pm 5V$  supply, the frequency range extends to 30kHz and very high Q values can also be obtained.

The LTC1060 is manufactured by using Linear Technology's enhanced LTCMOS<sup>™</sup> silicon gate process. Because of this, low offsets, high dynamic range, high center frequency Q product and excellent temperature stability are obtained.

The LTC1060 is pinout compatible with MF10.

LT, LTC and LT are registered trademarks of Linear Technology Corporation.  
 LTCMOS trademark of Linear Technology Corporation.

## TYPICAL APPLICATION

Single 5V, Gain of 1000 4th Order Bandpass Filter

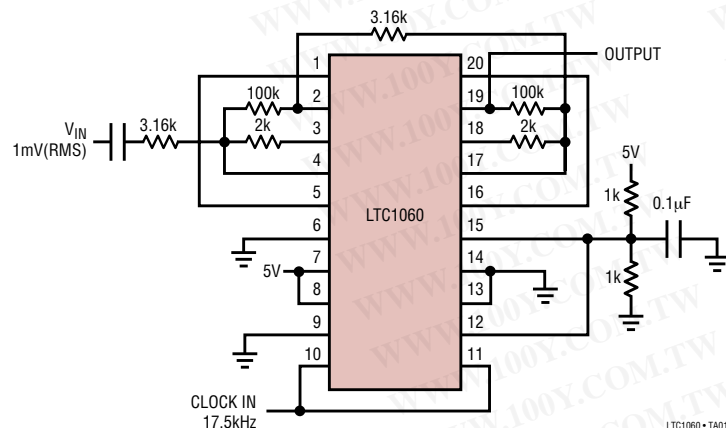

Amplitude Response

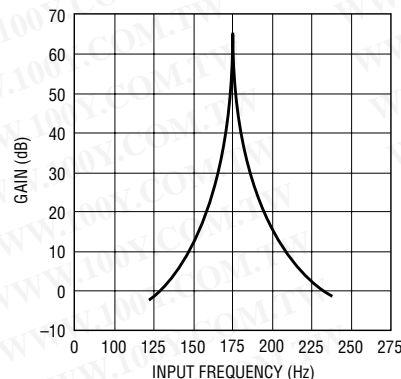

# LTC1060

## ABSOLUTE MAXIMUM RATINGS

(Note 1)

Supply Voltage .....	18V
Power Dissipation .....	500mW
Operating Temperature Range	
LTC1060AC/LTC1060C .....	$-40^{\circ}\text{C} \leq T_A \leq 85^{\circ}\text{C}$
LTC1060AM/LTC1060M .....	$-55^{\circ}\text{C} \leq T_A \leq 125^{\circ}\text{C}$
Storage Temperature Range .....	$-65^{\circ}\text{C}$ to $150^{\circ}\text{C}$
Lead Temperature (Soldering, 10 sec) .....	300°C

勝特力材料 886-3-5753170  
 勝特力电子(上海) 86-21-34970699  
 勝特力电子(深圳) 86-755-83298787  
[Http://www.100y.com.tw](http://www.100y.com.tw)

## PACKAGE/ORDER INFORMATION

TOP VIEW		ORDER PART NUMBER
LP <sub>A</sub> 1	20 LP <sub>B</sub>	LTC1060ACN LTC1060CN LTC1060CSW
BP <sub>A</sub> 2	19 BP <sub>B</sub>	
N/AP/HP <sub>A</sub> 3	18 N/AP/HP <sub>B</sub>	
INV <sub>A</sub> 4	17 INV <sub>B</sub>	
S1 <sub>A</sub> 5	16 S1 <sub>B</sub>	
S <sub>A/B</sub> 6	15 AGND	
V <sub>A</sub> <sup>+</sup> 7	14 V <sub>A</sub> <sup>-</sup>	
V <sub>D</sub> <sup>+</sup> 8	13 V <sub>D</sub> <sup>-</sup>	
LSH 9	12 50/100/HOLD	
CLK <sub>A</sub> 10	11 CLK <sub>B</sub>	
N PACKAGE 20-LEAD PDIP SW PACKAGE 20-LEAD PLASTIC SO WIDE $T_{JMAX} = 100^{\circ}\text{C}, \theta_{JA} = 100^{\circ}\text{C/W (N)}$ $T_{JMAX} = 150^{\circ}\text{C}, \theta_{JA} = 80^{\circ}\text{C/W (SW)}$		LTC1060ACJ LTC1060MJ LTC1060AMJ LTC1060CJ
J PACKAGE 20-LEAD CERDIP $T_{JMAX} = 150^{\circ}\text{C}, \theta_{JA} = 70^{\circ}\text{C/W}$		
<b>OBSOLETE PACKAGE</b> Consider the N20 and SW20 Package for Alternate Source		

Consult LTC Marketing for parts specified with wider operating temperature ranges.

## ELECTRICAL CHARACTERISTICS

The ● denotes specifications which apply over the full operating temperature range, otherwise specifications are at  $T_A = 25^{\circ}\text{C}$ . (Complete Filter)  $V_S = \pm 5\text{V}$ , unless otherwise noted.

PARAMETER	CONDITIONS	MIN	TYP	MAX	UNITS	
Center Frequency Range (See Applications Information)	$f_0 \cdot Q \leq 400\text{kHz}$ , Mode 1, Figure 4 $f_0 \cdot Q \leq 1.6\text{MHz}$ , Mode 1, Figure 4		0.1 to 20k 0.1 to 16k		Hz Hz	
Clock-to-Center Frequency Ratio						
LTC1060A	Mode 1, 50:1, $f_{CLK} = 250\text{kHz}$ , $Q = 10$	●		50 ± 0.3%		
LTC1060	Mode 1, 50:1, $f_{CLK} = 250\text{kHz}$ , $Q = 10$	●		50 ± 0.8%		
LTC1060A	Mode 1, 100:1, $f_{CLK} = 500\text{kHz}$ , $Q = 10$	●		100 ± 0.3%		
LTC1060	Mode 1, 100:1, $f_{CLK} = 500\text{kHz}$ , $Q = 10$	●		100 ± 0.8%		
Q Accuracy						
LTC1060A	Mode 1, 50:1 or 100:1, $f_0 = 5\text{kHz}$ , $Q = 10$	●	±0.5	3	%	
LTC1060	Mode 1, 50:1 or 100:1, $f_0 = 5\text{kHz}$ , $Q = 10$	●	±0.5	5	%	
$f_0$ Temperature Coefficient	Mode 1, $f_{CLK} < 500\text{kHz}$		-10		ppm/°C	
Q Temperature Coefficient	Mode 1, $f_{CLK} < 500\text{kHz}$ , $Q = 10$		20		ppm/°C	
DC Offset $V_{OS1}$		●	2	15	mV	
$V_{OS2}$	$f_{CLK} = 250\text{kHz}$ , 50:1, $S_{A/B} = \text{High}$	●	3	40	mV	
$V_{OS2}$	$f_{CLK} = 500\text{kHz}$ , 100:1, $S_{A/B} = \text{High}$	●	6	80	mV	
$V_{OS2}$	$f_{CLK} = 250\text{kHz}$ , 50:1, $S_{A/B} = \text{Low}$	●	2	30	mV	
$V_{OS2}$	$f_{CLK} = 500\text{kHz}$ , 100:1, $S_{A/B} = \text{Low}$	●	4	60	mV	
$V_{OS3}$	$f_{CLK} = 250\text{kHz}$ , 50:1, $S_{A/B} = \text{Low}$	●	2	30	mV	
$V_{OS3}$	$f_{CLK} = 500\text{kHz}$ , 100:1, $S_{A/B} = \text{Low}$	●	4	60	mV	
DC Lowpass Gain Accuracy	Mode 1, $R1 = R2 = 50\text{k}$		±0.1	2	%	
BP Gain Accuracy at $f_0$	Mode 1, $Q = 10$ , $f_0 = 5\text{kHz}$		±0.1		%	
Clock Feedthrough	$f_{CLK} \leq 1\text{MHz}$		10		mV(p-p)	
Max Clock Frequency			1.5		MHz	
Power Supply Current		●	3	5	8	mA
				12	mA	
Crosstalk				70	dB	

1060fb

# ELECTRICAL CHARACTERISTICS

The ● denotes specifications which apply over the full operating temperature range, otherwise specifications are at  $T_A = 25^\circ\text{C}$ . (Complete Filter)  $V_S = \pm 2.37\text{V}$ .

PARAMETER	CONDITIONS	MIN	TYP	MAX	UNITS
Center Frequency Range	$f_0 \cdot Q \leq 100\text{kHz}$		0.1 to 10k		Hz
Clock-to-Center Frequency Ratio				$50 \pm 0.5\%$	
LTC1060A	Mode 1, 50:1, $f_{\text{CLK}} = 250\text{kHz}$ , $Q = 10$	●			
LTC1060	Mode 1, 50:1, $f_{\text{CLK}} = 250\text{kHz}$ , $Q = 10$		$50 \pm 0.8\%$		
LTC1060A	Mode 1, 100:1, $f_{\text{CLK}} = 250\text{kHz}$ , $Q = 10$	●	$100 \pm 0.5\%$		
LTC1060	Mode 1, 100:1, $f_{\text{CLK}} = 250\text{kHz}$ , $Q = 10$		$100 \pm 0.8\%$		
Q Accuracy					%
LTC1060A	Mode1, 50:1 or 100:1, $f_0 = 2.5\text{kHz}$ , $Q = 10$		$\pm 2$		%
LTC1060	Mode1, 50:1 or 100:1, $f_0 = 2.5\text{kHz}$ , $Q = 10$		$\pm 4$		%
Max Clock Frequency			500		kHz
Power Supply Current			2.5	4	mA

The ● denotes specifications which apply over the full operating temperature range, otherwise specifications are at  $T_A = 25^\circ\text{C}$ . (Internal Op Amps).

PARAMETER	CONDITIONS	MIN	TYP	MAX	UNITS
Supply Voltage Range		$\pm 2.37$		$\pm 8$	V
Voltage Swings					V
LTC1060A	$V_S = \pm 5\text{V}$ , $R_L = 5\text{k}$ (Pins 1,2,19,20) $R_L = 3.5\text{k}$ (Pins 3,18)	$\pm 4$	$\pm 4$		V
LTC01060		$\pm 3.8$	$\pm 4$		V
LTC01060, LTC01060A		$\pm 3.6$	$\pm 4$		V
Output Short-Circuit Current	$V_S = \pm 5\text{V}$				mA
Source			25		mA
Sink			3		mA
Op Amp GBW Product	$V_S = \pm 5\text{V}$		2		MHz
Op Amp Slew Rate	$V_S = \pm 5\text{V}$		7		V/ $\mu\text{s}$
Op Amp DC Open Loop Gain	$R_L = 10\text{k}$ , $V_S = \pm 5\text{V}$		85		dB

Note 1: Absolute Maximum Ratings are those values beyond which the life of a device may be impaired.

## BLOCK DIAGRAM

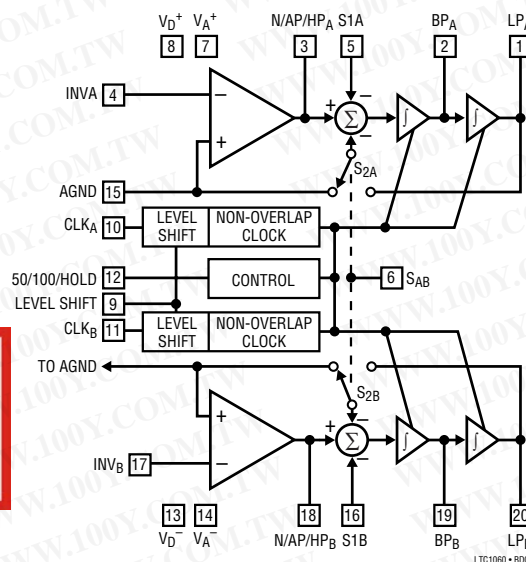

**勝特力材料 886-3-5753170**  
**勝特力电子(上海) 86-21-34970699**  
**勝特力电子(深圳) 86-755-83298787**  
[Http://www.100y.com.tw](http://www.100y.com.tw)

TYPICAL PERFORMANCE CHARACTERISTICS

Graph 1. Mode 1:  
 ( $f_{CLK}/f_0$ ) Deviation vs Q

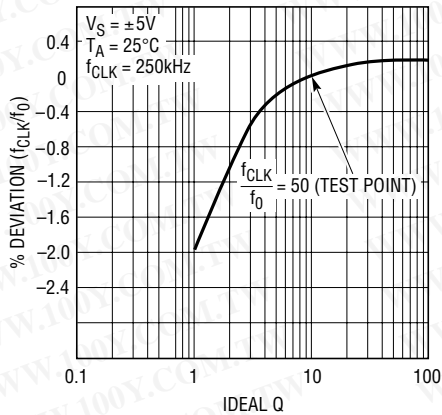

LTC1060 • TPC01

Graph 2. Mode 1:  
 ( $f_{CLK}/f_0$ ) Deviation vs Q

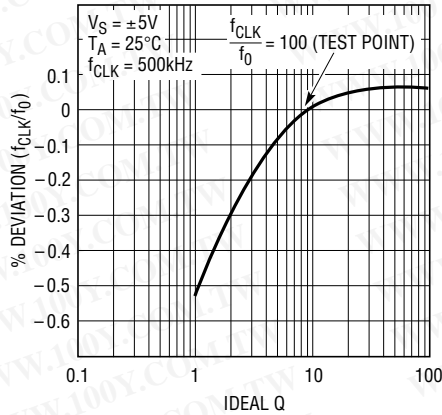

LTC1060 • TPC02

Graph 3. Mode 1:  
 Q Error vs Clock Frequency

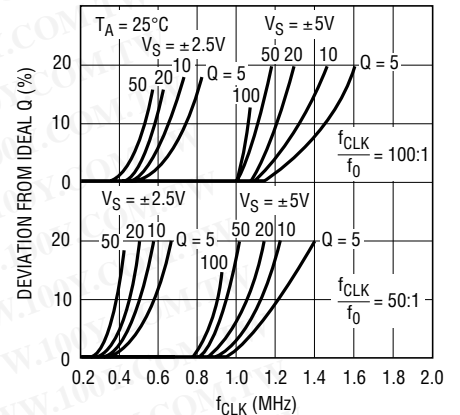

LTC1060 • TPC03

Graph 4. Mode 1:  
 Q Error vs Clock Frequency

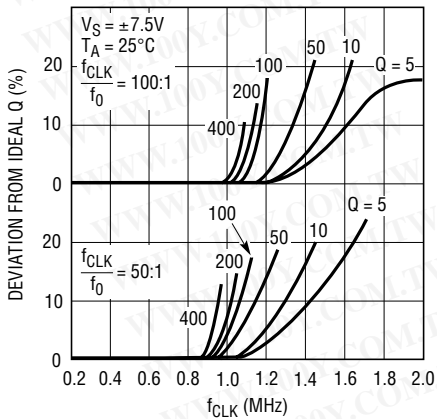

LTC1060 • TPC04

Graph 5. Mode 1: Measured Q vs  
 $f_{CLK}$  and Temperature

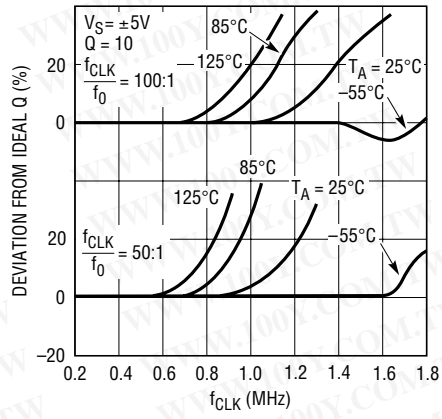

LTC1060 • TPC05

Graph 6. Mode 1:  
 ( $f_{CLK}/f_0$ ) vs  $f_{CLK}$  and Q

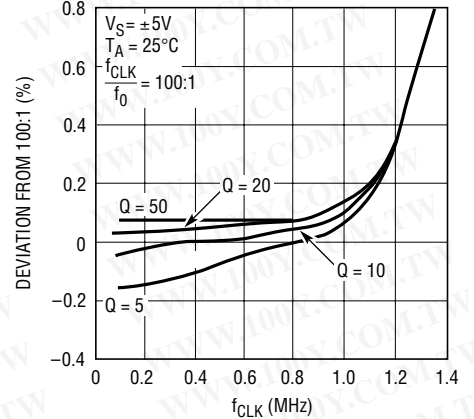

LTC1060 • TPC06

Graph 7. Mode 1:  
 ( $f_{CLK}/f_0$ ) vs  $f_{CLK}$  and Q

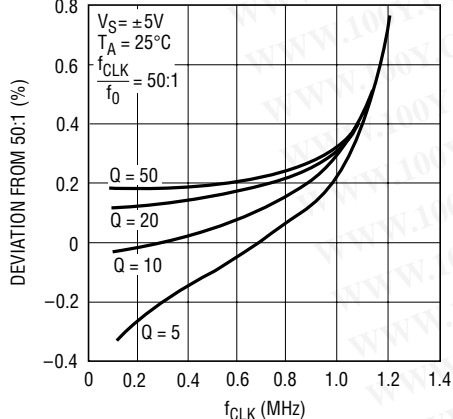

LTC1060 • TPC07

Graph 8. Mode 1: ( $f_{CLK}/f_0$ ) vs  $f_{CLK}$   
 and Temperature

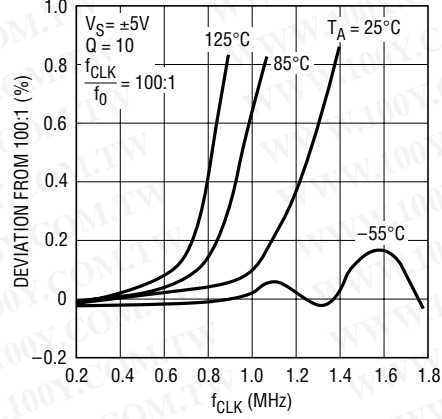

LTC1060 • TPC08

Graph 9. Mode 1: ( $f_{CLK}/f_0$ ) vs  $f_{CLK}$   
 and Temperature

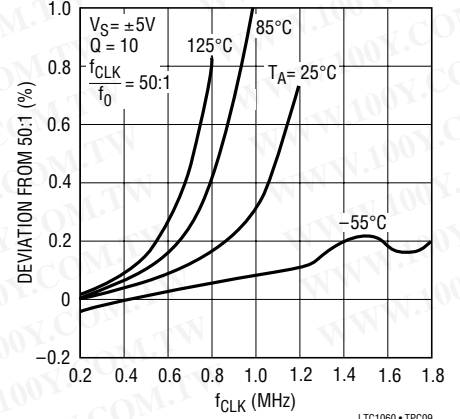

LTC1060 • TPC09

# TYPICAL PERFORMANCE CHARACTERISTICS

**Graph 10. Mode 1:**  
 $(f_{CLK}/f_0)$  vs  $f_{CLK}$  and Q

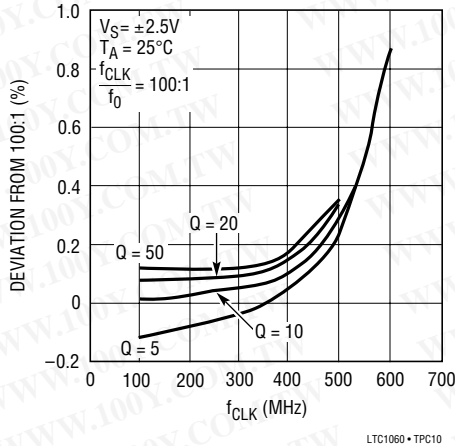

LTC1060 • TPC10

**Graph 11. Mode 1:**  
 $(f_{CLK}/f_0)$  vs  $f_{CLK}$  and Q

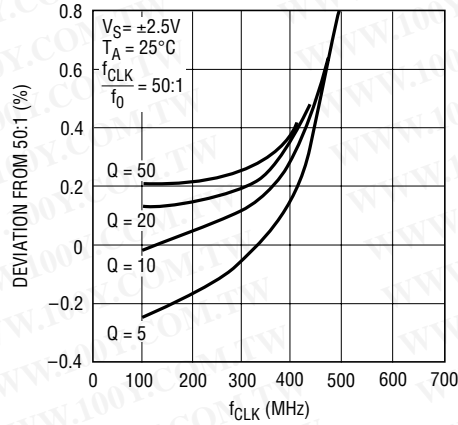

LTC1060 • TPC11

**Graph 12. Mode 1:**  $(f_{CLK}/f_0)$  vs  $f_{CLK}$  and Temperature

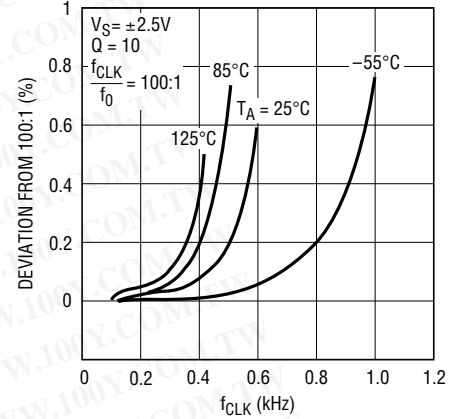

LTC1060 • TPC12

**Graph 13. Mode 1:**  $(f_{CLK}/f_0)$  vs  $f_{CLK}$  and Temperature

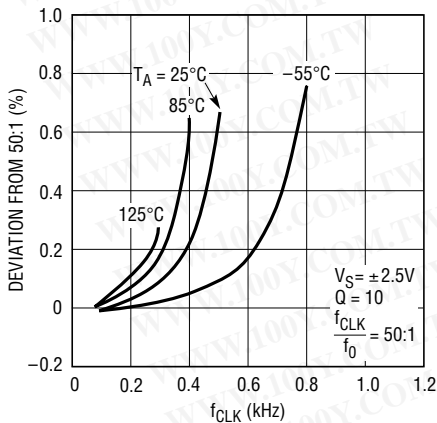

LTC1060 • TPC13

**Graph 14. Mode 1:**  
 Notch Depth vs Clock Frequency

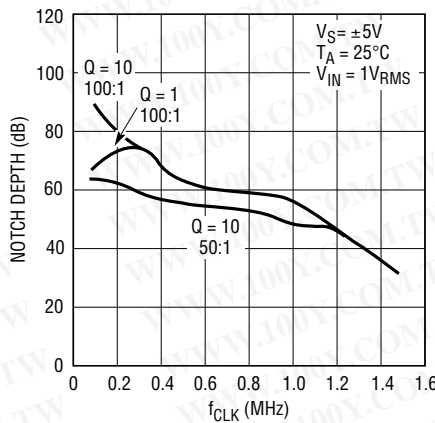

LTC1060 • TPC14

**Graph 15. Mode 3:** Deviation of  $(f_{CLK}/f_0)$  with Respect to Q = 10 Measurement

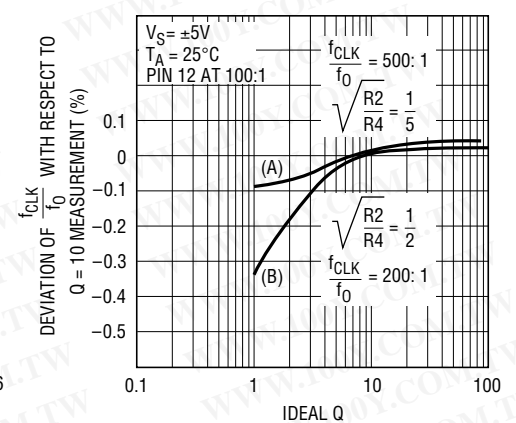

LTC1060 • TPC15

**Graph 16. Mode 3:**  
 Q Error vs Clock Frequency

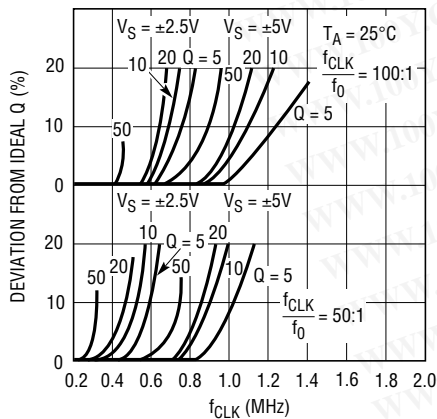

LTC1060 • TPC16

**Graph 17. Mode 3 (R2 = R4):**  
 Q Error vs Clock Frequency

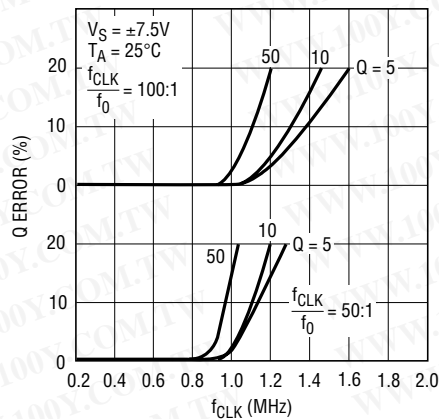

LTC1060 • TPC17

**Graph 18. Mode 3 (R2 = R4):**  
 Measured Q vs  $f_{CLK}$  and Temperature

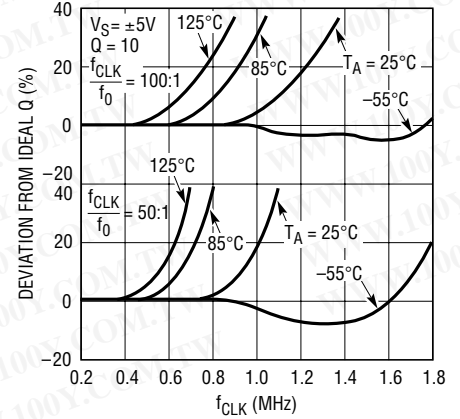

LTC1060 • TPC18

1060f8

TYPICAL PERFORMANCE CHARACTERISTICS

Graph 19. Mode 3 (R2 = R4):  
 ( $f_{CLK}/f_0$ ) vs  $f_{CLK}$  and Q

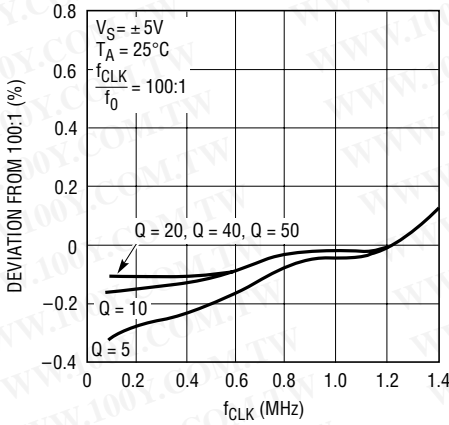

LTC1060 • TPC19

Graph 20. Mode 3 (R2 = R4):  
 ( $f_{CLK}/f_0$ ) vs  $f_{CLK}$  and Q

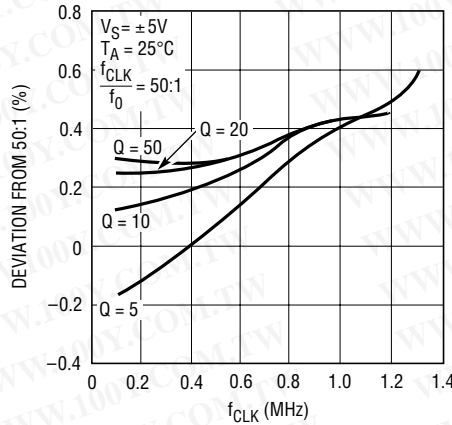

LTC1060 • TPC20

Graph 21. Mode 3 (R2 = R4):  
 ( $f_{CLK}/f_0$ ) vs  $f_{CLK}$  and Temperature

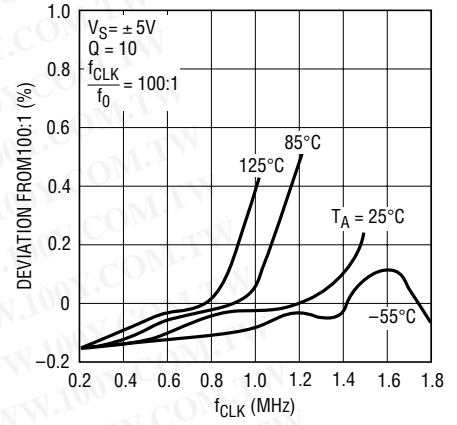

LTC1060 • TPC21

Graph 22. Mode 3 (R2 = R4):  
 ( $f_{CLK}/f_0$ ) vs  $f_{CLK}$  and Temperature

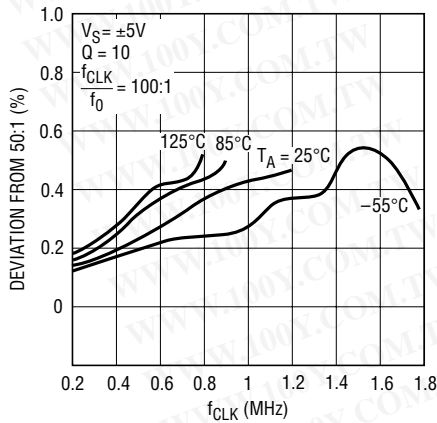

LTC1060 • TPC22

Graph 23. Mode 3 (R2 = R4):  
 ( $f_{CLK}/f_0$ ) vs  $f_{CLK}$  and Temperature

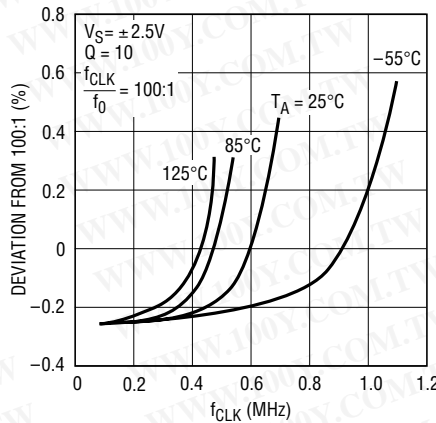

LTC1060 • TPC23

Graph 24. Mode 3 (R2 = R4):  
 ( $f_{CLK}/f_0$ ) vs  $f_{CLK}$  and Temperature

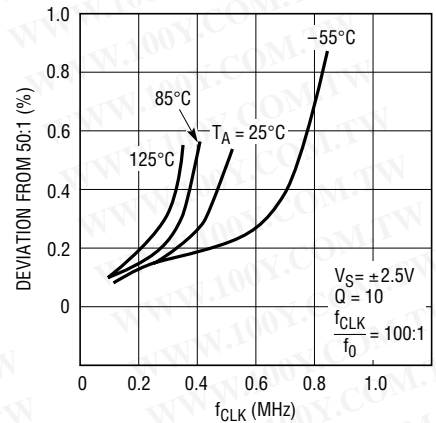

LTC1060 • TPC24

Graph 25. Mode 1c (R5 = 0),  
 Mode 2 (R2 = R4) Q Error vs  
 Clock Frequency

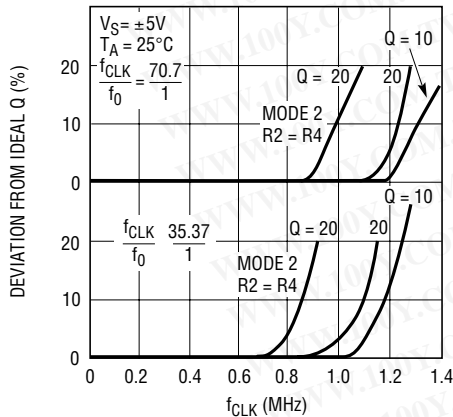

LTC1060 • TPC25

Graph 26. Supply Current vs  
 Supply Voltage

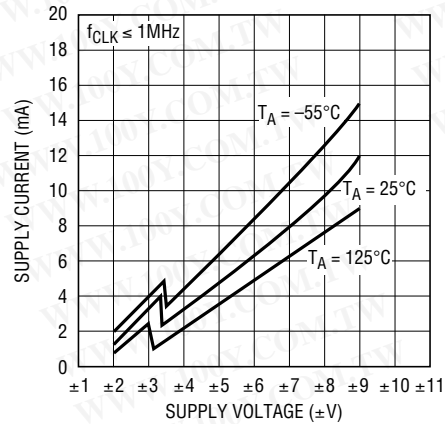

LTC1060 • TPC26

## PIN DESCRIPTION AND APPLICATIONS INFORMATION

### Power Supplies

The  $V^+_A$  and  $V^+_D$  (pins 7 and 8) and the  $V^-_A$  and  $V^-_D$  (Pins 14 and 13) are, respectively, the analog and digital positive and negative supply pins. For most cases, Pins 7 and 8 should be tied together and bypassed by a 0.1  $\mu$ F disc ceramic capacitor. The same holds for Pins 13 and 14. If the LTC1060 operates in a high digital noise environment, the supply pins can be bypassed separately. Pins 7 and 8 are internally connected through the IC substrate and should be biased from the same DC source. Pins 13 and 14 should also be biased from the same DC source.

The LTC1060 is designed to operate with  $\pm 2.5V$  supply (or single 5V) and with  $\pm 5V$  to  $\pm 8V$  supplies. The minimum supply, where the filter operates reliably, is  $\pm 2.37V$ . With low supply operation, the maximum input clock frequency is about 500kHz. Beyond this, the device exhibits excessive Q enhancement and center frequency errors.

### Clock Input Pins and Level Shift

The level shift (LSh) Pin 9 is used to accommodate T<sup>2</sup>L or CMOS clock levels. With dual supplies equal or higher to  $\pm 4.5V$ , Pin 9 should be connected to ground (same potential as the AGND pin). Under these conditions the clock levels can be T<sup>2</sup>L or CMOS. With single supply operation, the negative supply pins and the LSh pin should be tied to the system ground. The AGND, Pin 15, should be biased at 1/2 supplies, as shown in the “Single 5V Gain of 1000 4th Order Bandpass Filter” circuit. Again, under these conditions, the clock levels can be T<sup>2</sup>L or CMOS. The input clock pins (10,11) share the same level shift pin. The clock logic threshold level over temperature is typically 1.5V  $\pm$  0.1V above the LSh pin potential. The duty cycle of the input clock should be close to 50%. For clock frequencies below 1MHz, the ( $f_{CLK}/f_0$ ) ratio is independent from the clock input levels and from its rise and fall times. Fast rising clock edges, however, improve the filter DC offsets. For clock frequencies above 1MHz, T<sup>2</sup>L level clocks are recommended.

### 50/100/Hold (Pin 12)

By tying Pin 12 to ( $V^+_A$  and  $V^+_D$ ), the filter operates in the 50:1 mode. With  $\pm 5V$  supplies, Pin 12 can be typically 1V below the positive supply without affecting the 50:1

operation of the device. By tying Pin 12 to 1/2 supplies (which should be the AGND potential), the LTC1060 operates in the 100:1 mode. The 1/2 supply bias of Pin 12 can vary around the 1/2 supply potential without affecting the 100:1 filter operation. This is shown in Table 1.

When Pin 12 is shorted to the negative supply pin, the filter operation is stopped and the bandpass and lowpass outputs act as a S/H circuit holding the last sample. The hold step is 20mV and the droop rate is 150 $\mu$ V/second!

Table 1

TOTAL POWER SUPPLY	VOLTAGE RANGE OF PIN 12 FOR 100:1 OPERATION
5V	2.5 $\pm$ 0.5V
10V	5V $\pm$ 1V
15V	7.5V $\pm$ 1.5V

### S<sub>1A</sub>, S<sub>1B</sub> (Pins 5 and 16)

These are voltage signal input pins and, if used, they should be driven with a source impedance below 5k $\Omega$ . The S<sub>1A</sub>, S<sub>1B</sub> pins can be used to alter the CLK to center frequency ratio ( $f_{CLK}/f_0$ ) of the filter (see Modes 1b, 1c, 2a, 2b) or to feedforward the input signal for allpass filter configurations (see Modes 4 and 5). When these pins are not used, they should be tied to the AGND pin.

### S<sub>A/B</sub> (Pin 6)

When S<sub>A/B</sub> is high, the S2 input of the filter's voltage summer (see Block Diagram) is tied to the lowpass output. This frees the S1 pin to realize various modes of operation for improved applications flexibility. When the S<sub>A/B</sub> pin is connected to the negative supply, the S2 input switches to ground and internally becomes inactive. This improves the filter noise performance and typically lowers the value of the offset  $V_{OS2}$ .

### AGND (Pin 15)

This should be connected to the system ground for dual supply operation. When the LTC1060 operates with a single positive supply, the analog ground pin should be tied to 1/2 supply and bypassed with a 0.1  $\mu$ F capacitor, as shown in the application, “Single 5V, Gain of 1000 4th Order Bandpass Filter.” The positive inputs of all the

## APPLICATIONS INFORMATION

internal op amps, as well as the reference point of all the internal switches are connected to the AGND pin. Because of this, a “clean” ground is recommended.

### $f_{CLK}/f_0$ Ratio

The  $f_{CLK}/f_0$  reference of 100:1 or 50:1 is derived from the filter center frequency measured in mode 1, with a  $Q = 10$  and  $V_S = \pm 5V$ . The clock frequencies are, respectively, 500kHz/250kHz for the 100:1/150:1 measurement. All the curves shown in the Typical Performance Characteristics section are normalized to the above references.

Graphs 1 and 2 in the Typical Performance Characteristics show the  $(f_{CLK}/f_0)$  variation versus values of ideal  $Q$ . The LTC1060 is a sampled data filter and it only approximates continuous time filters. In this data sheet, the LTC1060 is treated in the frequency domain because this approximation is good enough for most filter applications. The LTC1060 deviates from its ideal continuous filter model when the  $(f_{CLK}/f_0)$  ratio decreases and when the  $Q$ 's are low. Since low  $Q$  filters are not selective, the frequency domain approximation is well justified. In Graph 15 the LTC1060 is connected in mode 3 and its  $(f_{CLK}/f_0)$  ratio is adjusted to 200:1 and 500:1. Under these conditions, the filter is over-sampled and the  $(f_{CLK}/f_0)$  curves are nearly independent of the  $Q$  values. In mode 3, the  $(f_{CLK}/f_0)$  ratio typically deviates from the tested one in mode 1 by  $\pm 0.1\%$ .

### $f_0 \times Q$ Product Ratio

This is a figure of merit of general purpose active filter building blocks. The  $f_0 \times Q$  product of the LTC1060 depends on the clock frequency, the power supply voltages, the junction temperature and the mode of operation.

At 25°C ambient temperature for  $\pm 5V$  supplies, and for clock frequencies below 1MHz, in mode 1 and its derivatives, the  $f_0 \times Q$  product is mainly limited by the desired  $f_0$  and  $Q$  accuracy. For instance, from Graph 4 at 50:1 and for  $f_{CLK}$  below 800kHz, a predictable ideal  $Q$  of 400 can be obtained. Under this condition, a respectable  $f_0 \times Q$  product of 6.4MHz is achieved. The 16kHz center frequency will be about 0.22% off from the tested value at 250kHz clock (see Graph 1). For the same clock frequency of 800kHz and for the same  $Q$  value of 400, the  $f_0 \times Q$  product can be further increased if the

clock-to-center frequency is lowered below 50:1. In mode 1c with  $R_6 = 0$  and  $R_6 = \infty$ , the  $(f_{CLK}/f_0)$  ratio is  $50/\sqrt{2}$ . The  $f_0 \times Q$  product can now be increased to 9MHz since, with the same clock frequency and same  $Q$  value, the filter can handle a center frequency of  $16kHz \times \sqrt{2}$ .

For clock frequencies above 1MHz, the  $f_0 \times Q$  product is limited by the clock frequency itself. From Graph 4 at  $\pm 7.5V$  supply, 50:1 and 1.4MHz clock, a  $Q$  of 5 has about 8% error; the measured 28kHz center frequency was skewed by 0.8% with respect to the guaranteed value at 250kHz clock. Under these conditions, the  $f_0 \times Q$  product is only 140kHz but the filter can handle higher input signal frequencies than the 800kHz clock frequency, very high  $Q$  case described above.

Mode 3, Figure 11, and the modes of operation where  $R_4$  is finite, are “slower” than the basic mode 1. This is shown in Graph 16 and 17. The resistor  $R_4$  places the input op amp inside the resonant loop. The finite GBW of this op amp creates an additional phase shift and enhances the  $Q$  value at high clock frequencies. Graph 16 was drawn with a small capacitor,  $C_C$ , placed across  $R_4$  and as such, at  $V_S = \pm 5V$ , the  $(1/2\pi R_4 C_C) = 2MHz$ . With  $V_S = \pm 2.5V$  the  $(1/2\pi R_4 C_C)$  should be equal to 1.4MHz. This allows the  $Q$  curve to be slightly “flatter” over a wider range of clock frequencies. If, at  $\pm 5V$  supply, the clock is below 900kHz (or 400kHz for  $V_S = \pm 2.5V$ ), this capacitor,  $C_C$ , is not needed.

For Graph 25, the clock-to-center frequency ratios are altered to 70.7:1 and 35.35:1. This is done by using mode 1c with  $R_5 = 0$ , Figure 7, or mode 2 with  $R_2 = R_4 = 10k\Omega$ . The mode 1c, where the input op amp is outside the main loop, is much faster. Mode 2, however, is more versatile. At 50:1, and for  $T_A = 25^\circ C$  the mode 1c can be tuned for center frequencies up to 30kHz.

### Output Noise

The wideband RMS noise of the LTC1060 outputs is nearly independent from the clock frequency, provided that the clock itself does not become part of the noise. The LTC1060 noise slightly decreases with  $\pm 2.5V$  supply. The noise at the BP and LP outputs increases for high  $Q$ 's. Table 2 shows typical values of wideband RMS noise. The numbers in parentheses are the noise measurement in mode 1 with the  $S_{A/B}$  pin shorted to  $V^-$  as shown in Figure 25.

## APPLICATIONS INFORMATION

Table 2. Wideband RMS Noise

V <sub>S</sub>	$\frac{f_{CLK}}{f_0}$	NOTCH/HP ( $\mu V_{RMS}$ )	BP ( $\mu V_{RMS}$ )	LP ( $\mu V_{RMS}$ )	CONDITIONS
±5V	50:1	49 (42)	52 (43)	75 (65)	Mode1, R1 = R2 = R3 Q = 1
±5V	100:1	70 (55)	80 (58)	90 (88)	
±2.5V	50:1	33 (31)	36 (32)	48 (43)	
±2.5V	100:1	48 (40)	52 (40)	66 (55)	
±5V	50:1	20 (18)	150 (125)	186 (155)	Mode 1, Q = 10 R1 = R3 for BP out R1 = R2 for LP out
±5V	100:1	25 (21)	220 (160)	240 (180)	
±2.5V	50:1	16 (15)	100 (80)	106 (87)	
±2.5V	100:1	20 (17)	150 (105)	150 (119)	
±5V	50:1	57	57	62	Mode 3, R1 = R2 = R3 = R4 Q = 1
±5V	100:1	72	72	80	
±2.5V	50:1	40	40	42	
±2.5V	100:1	50	50	53	
±5V	50:1	135	120	140	Mode 3, R2 = R4, Q = 10 R3 = R1 for BP out R4 = R1 for LP and HP out
±5V	100:1	170	160	185	
±2.5V	50:1	100	88	100	
±2.5V	100:1	125	115	130	

### Short-Circuit Currents

Short circuits to ground, positive or negative power supply are allowed as long as the power supplies do not exceed ±5V and the ambient temperature stays below 85°C. Above ±5V and at elevated temperatures, continuous

short circuits to the negative power supply will cause excessive currents to flow. Under these conditions, the device will get damaged if the short-circuit current is allowed to exceed 80mA.

## DEFINITION OF FILTER FUNCTIONS

Each building block of the LTC1060, together with an external clock and a few resistors, closely approximates 2nd order filter functions. These are tabulated below in the frequency domain.

- Bandpass function:** available at the bandpass output Pins 2 (19). (Figure 1.)

$$G(s) = H_{OBP} \frac{s\omega_0/Q}{s^2 + (s\omega_0/Q) + \omega_0^2}$$

$H_{OBP}$  = Gain at  $\omega = \omega_0$

$f_0 = \omega/2\pi$ ;  $f_0$  is the center frequency of the complex pole pair. At this frequency, the phase shift between input and output is  $-180^\circ$ .

$Q$  = Quality factor of the complex pole pair. It is the ratio of  $f_0$  to the  $-3dB$  bandwidth of the 2nd order bandpass function. The  $Q$  is always measured at the filter BP output.

- Lowpass function:** available at the LP output Pins 1 (20). (Figure 2.)

$$G(s) = H_{OLP} \frac{\omega_0^2}{s^2 + s(\omega_0/Q) + \omega_0^2}$$

$H_{OLP}$  DC gain of the LP output.

## DEFINITION OF FILTER FUNCTIONS

3. **Highpass function:** available only in mode 3 at the output Pins 3 (18). (Figure 3.)

$$G(s) = H_{OHP} \frac{s^2}{s^2 + s(\omega_0/Q) + \omega_0^2}$$

$$H_{OHP} = \text{gain of the HP output for } f \rightarrow \frac{f_{CLK}}{2}$$

4. **Notch function:** available at Pins 3 (18) for several modes of operation.

$$G(s) = (H_{ON2}) \frac{s^2 + \omega_0^2}{s^2 + (s\omega_0/Q) + \omega_0^2}$$

$$H_{ON2} = \text{gain of the notch output for } f \rightarrow \frac{f_{CLK}}{2}$$

$$H_{ON1} = \text{gain of the notch output for } f \rightarrow 0$$

$f_n = \omega_n/2\pi$ ;  $f_n$  is the frequency of the notch occurrence.

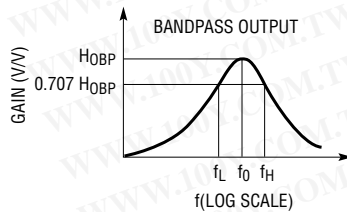

$$Q = \frac{f_0}{f_H - f_L}; f_0 = \sqrt{f_L f_H}$$

$$f_L = f_0 \left( \frac{-1}{2Q} + \sqrt{\left(\frac{1}{2Q}\right)^2 + 1} \right)$$

$$f_H = f_0 \left( \frac{1}{2Q} + \sqrt{\left(\frac{1}{2Q}\right)^2 + 1} \right)$$

TLC1060 • DFF01

Figure 1

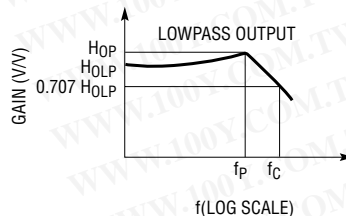

$$f_c = f_0 \cdot \sqrt{\left(1 - \frac{1}{2Q^2}\right) + \sqrt{\left(1 - \frac{1}{2Q^2}\right)^2 + 1}}$$

$$f_p = f_0 \sqrt{1 - \frac{1}{2Q^2}}$$

$$H_{OP} = H_{OLP} \cdot \frac{1}{\frac{1}{Q} \sqrt{1 - \frac{1}{4Q^2}}}$$

TLC1060 • DFF02

Figure 2

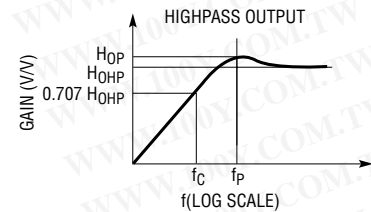

$$f_c = f_0 \cdot \left[ \sqrt{\left(1 - \frac{1}{2Q^2}\right) + \sqrt{\left(1 - \frac{1}{2Q^2}\right)^2 + 1}} \right]^{-1}$$

$$f_p = f_0 \cdot \left[ \sqrt{1 - \frac{1}{2Q^2}} \right]^{-1}$$

$$H_{OP} = H_{OHP} \cdot \frac{1}{\frac{1}{Q} \sqrt{1 - \frac{1}{4Q^2}}}$$

TLC1060 • DFF03

Figure 3

## MODES OF OPERATION

Table 3. Modes of Operation: 1st Order Functions

MODE	PIN 2 (19)	PIN 3 (18)	$f_c$	$f_z$
6a	LP	HP	$\frac{f_{CLK}}{100(50)} \cdot \frac{R2}{R3}$	
6b	LP	LP	$\frac{f_{CLK}}{100(50)} \cdot \frac{R2}{R3}$	
7	LP	AP	$\frac{f_{CLK}}{100(50)} \cdot \frac{R2}{R3}$	$\frac{f_{CLK}}{100(50)} \cdot \frac{R2}{R3}$

# MODES OF OPERATION

Table 4. Modes of Operation: 2nd Order Functions

MODE	PIN 1 (20)	PIN 2 (19)	PIN 3 (18)	$f_0$	$f_n$
1	LP	BP	Notch	$\frac{f_{CLK}}{100(50)}$	
1a	LP	BP	BP	$\frac{f_{CLK}}{100(50)}$	
1b	LP	BP	Notch	$\frac{f_{CLK}}{100(50)} \cdot \sqrt{\frac{R6}{R5 + R6}}$	$\frac{f_{CLK}}{100(50)} \cdot \sqrt{\frac{R6}{R5 + R6}}$
1c	LP	BP	Notch	$\frac{f_{CLK}}{100(50)} \cdot \sqrt{1 + \frac{R6}{R5 + R6}}$	$\frac{f_{CLK}}{100(50)} \cdot \sqrt{1 + \frac{R6}{R5 + R6}}$
2	LP	BP	Notch	$\frac{f_{CLK}}{100(50)} \cdot \sqrt{1 + \frac{R2}{R4}}$	$\frac{f_{CLK}}{100(50)}$
2a	LP	BP	Notch	$\frac{f_{CLK}}{100(50)} \cdot \sqrt{1 + \frac{R2}{R4} + \frac{R6}{R5 + R6}}$	$\frac{f_{CLK}}{100(50)} \cdot \sqrt{1 + \frac{R6}{R5 + R6}}$
2b	LP	BP	Notch	$\frac{f_{CLK}}{100(50)} \cdot \sqrt{\frac{R2}{R4} + \frac{R6}{R5 + R6}}$	$\frac{f_{CLK}}{100(50)} \cdot \sqrt{\frac{R6}{R5 + R6}}$
3	LP	BP	HP	$\frac{f_{CLK}}{100(50)} \cdot \sqrt{\frac{R2}{R4}}$	
3a	LP	BP	Notch	$\frac{f_{CLK}}{100(50)} \cdot \sqrt{\frac{R2}{R4}}$	$\frac{f_{CLK}}{100(50)} \cdot \sqrt{\frac{R_h}{R_l}}$
4	LP	BP	AP	$\frac{f_{CLK}}{100(50)}$	
4a	LP	BP	AP	$\frac{f_{CLK}}{100(50)} \cdot \sqrt{\frac{R2}{R4}}$	
5	LP	BP	CZ	$\frac{f_{CLK}}{100(50)} \cdot \sqrt{1 + \frac{R2}{R4}}$	$\frac{f_{CLK}}{100(50)} \cdot \sqrt{1 - \frac{R1}{R4}}$

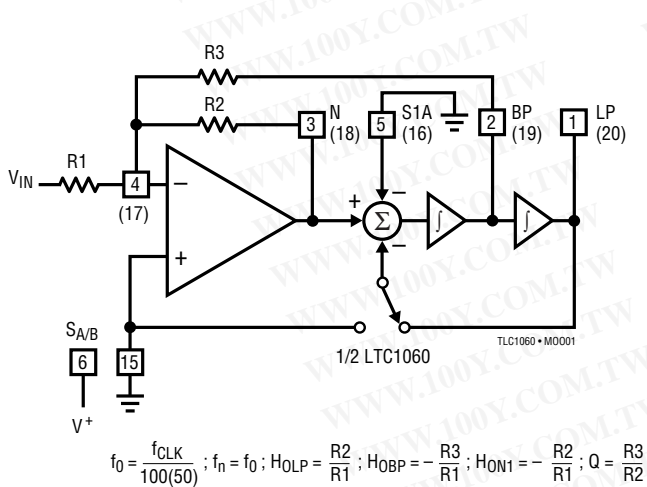

Figure 4. Mode 1: 2nd Order Filter Providing Notch, Bandpass, Lowpass

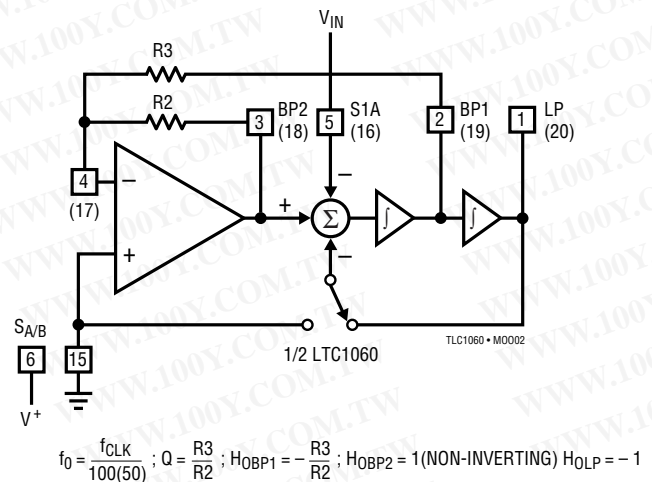

Figure 5. Mode 1a: 2nd Order Filter Providing Bandpass, Lowpass

# LTC1060

## MODES OF OPERATION

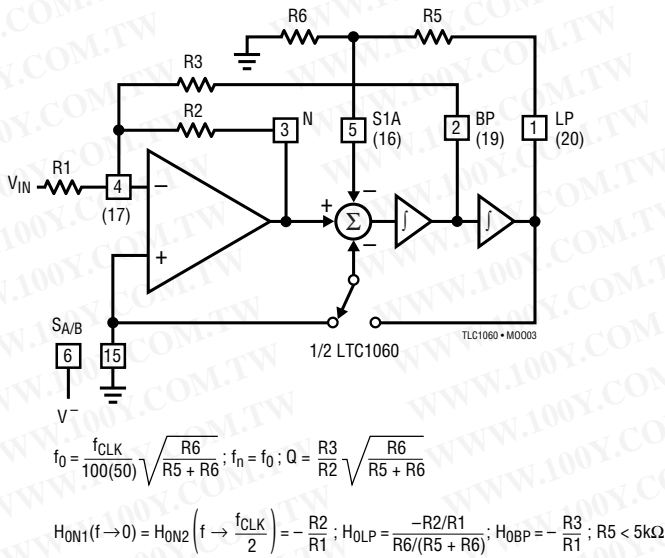

Figure 6. Mode 1b: 2nd Order Filter Providing Notch, Bandpass, Lowpass

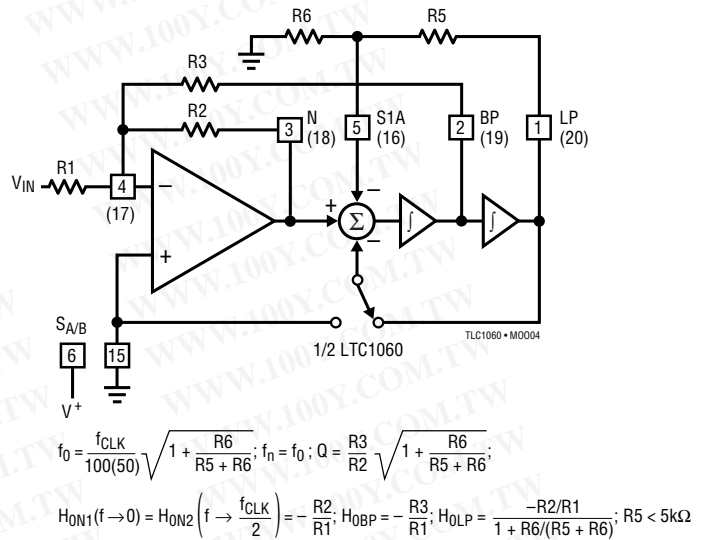

Figure 7. Mode 1c: 2nd Order Filter Providing Notch, Bandpass, Lowpass

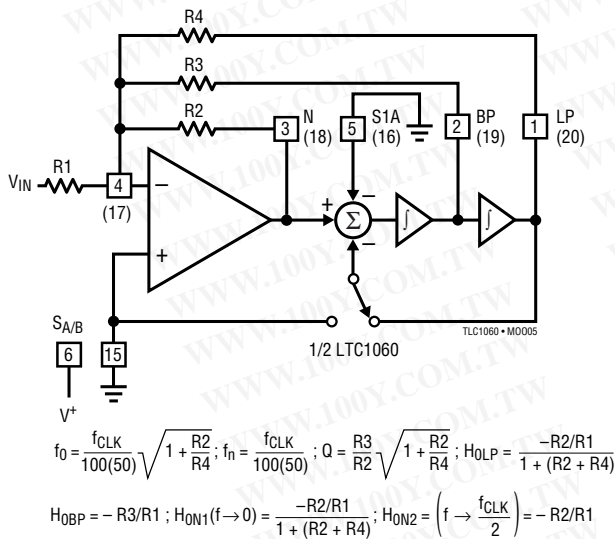

Figure 8. Mode 2: 2nd Order Filter Providing Notch, Bandpass, Lowpass

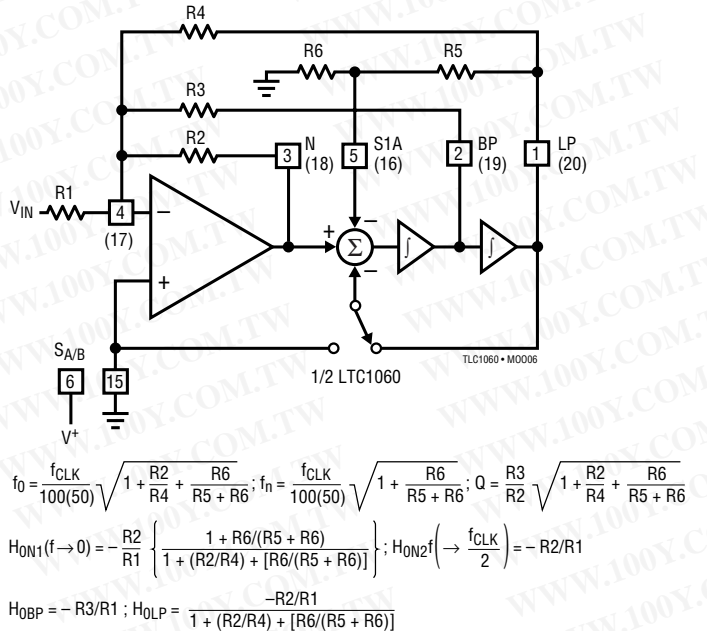
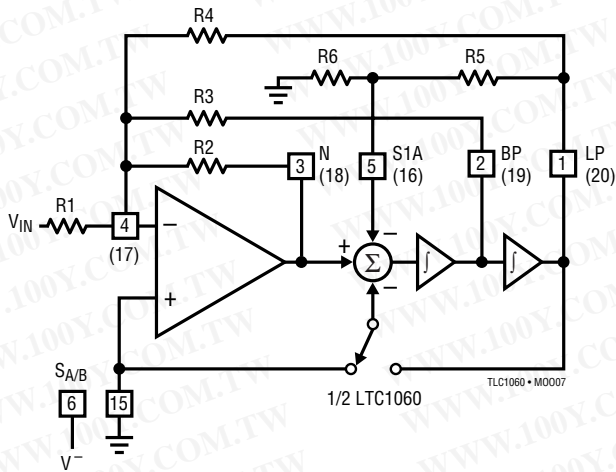

Figure 9. Mode 2a: 2nd Order Filter Providing Notch, Bandpass, Lowpass

# MODES OF OPERATION



$$f_0 = \frac{f_{CLK}}{100(50)} \sqrt{\frac{R_2}{R_4} + \frac{R_6}{R_5 + R_6}}; f_n = \frac{f_{CLK}}{100(50)} \sqrt{\frac{R_6}{R_5 + R_6}}; Q = \frac{R_3}{R_2} \sqrt{\frac{R_2}{R_4} + \frac{R_6}{R_5 + R_6}}$$

$$H_{0N1}(f \rightarrow 0) = -\frac{R_2}{R_1} \left\{ \frac{R_6/(R_5 + R_6)}{(R_2/R_4) + [R_6/(R_5 + R_6)]} \right\}; H_{0N2} \left( f \rightarrow \frac{f_{CLK}}{2} \right) = -R_2/R_1$$

$$H_{0BP} = -R_3/R_1; H_{0LP} = \frac{-R_2/R_1}{(R_2/R_4) + [R_6/(R_5 + R_6)]}$$

Figure 10. Mode 2b: 2nd Order Filter Providing Notch, Bandpass, Lowpass

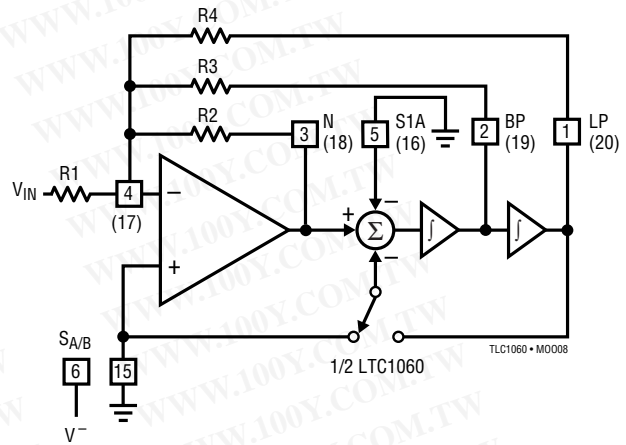

$$f_0 = \frac{f_{CLK}}{100(50)} \sqrt{\frac{R_2}{R_4}}; Q = \frac{R_3}{R_2} \sqrt{\frac{R_2}{R_4}}; H_{0HP} = -R_2/R_1; H_{0BP} = -R_3/R_1; H_{0LP} = -R_4/R_1$$

Figure 11. Mode 3: 2nd Order Filter Providing Highpass, Bandpass, Lowpass

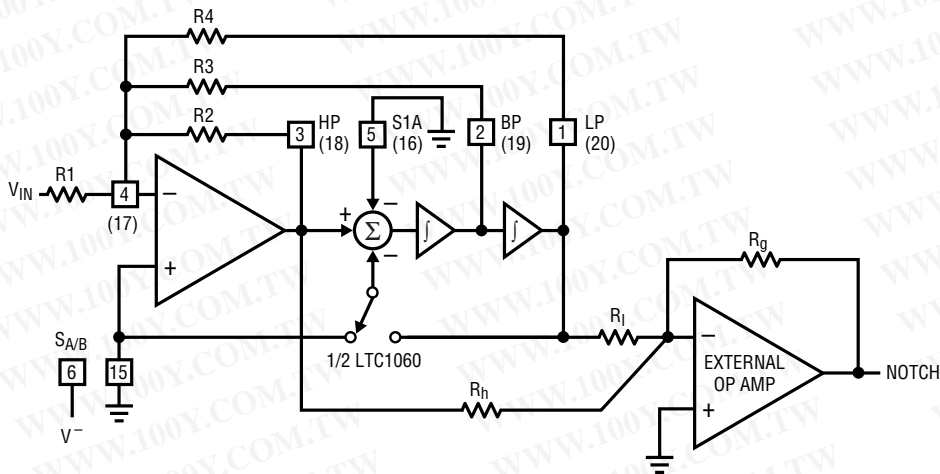

$$f_0 = \frac{f_{CLK}}{100(50)} \sqrt{\frac{R_2}{R_4}}; f_n = \frac{f_{CLK}}{100(50)} \sqrt{\frac{R_h}{R_1}}; H_{0HP} = -R_2/R_1; H_{0BP} = -R_3/R_1; H_{0LP} = -R_4/R_1$$

$$H_{0N1}(f \rightarrow 0) = \frac{R_g}{R_1} \cdot \frac{R_4}{R_1}; H_{0N2} \left( f \rightarrow \frac{f_{CLK}}{2} \right) = \frac{R_g}{R_h} \cdot \frac{R_2}{R_1}; H_{0N}(f = f_0) = Q \left( \frac{R_g}{R_1} H_{0LP} - \frac{R_g}{R_h} H_{0HP} \right); Q = \frac{R_3}{R_2} \sqrt{\frac{R_2}{R_4}}$$

Figure 12. Mode 3a: 2nd Order Filter Providing Highpass, Bandpass, Lowpass, Notch

TLC1060 • M0009

MODES OF OPERATION

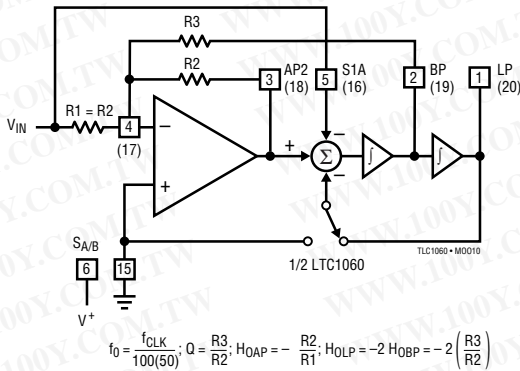

Figure 13. Mode 4: 2nd Order Filter Providing Allpass, Bandpass, Lowpass

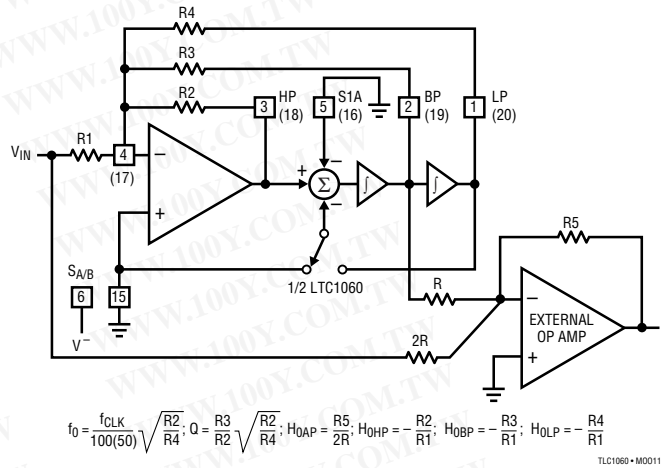

Figure 14. Mode 4a: 2nd Order Filter Providing Highpass, Bandpass, Lowpass, Allpass

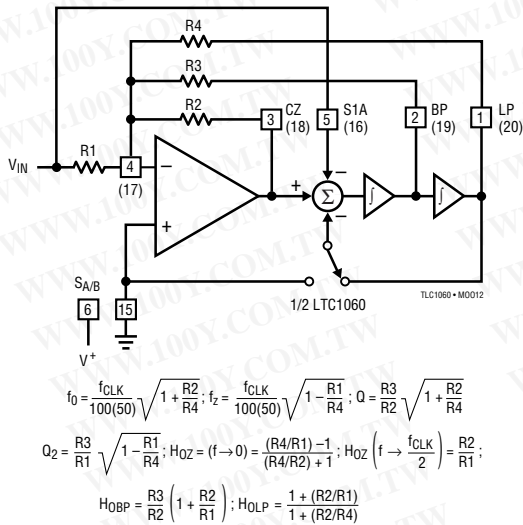

Figure 15. Mode 5: 2nd Order Filter Providing Numerator Complex Zeros, Bandpass, Lowpass

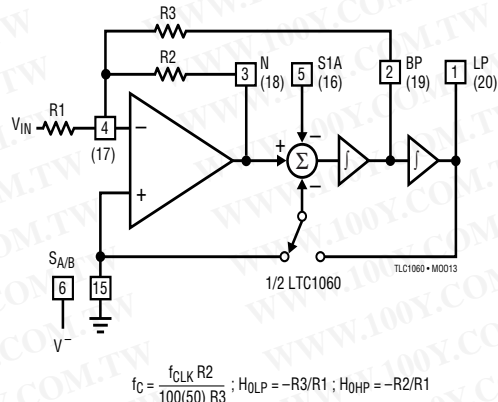

Figure 16. Mode 6a: 1st Order Filter Providing Highpass, Lowpass

勝特力材料 886-3-5753170  
 勝特力电子(上海) 86-21-34970699  
 勝特力电子(深圳) 86-755-83298787  
[Http://www.100y.com.tw](http://www.100y.com.tw)

## MODES OF OPERATION

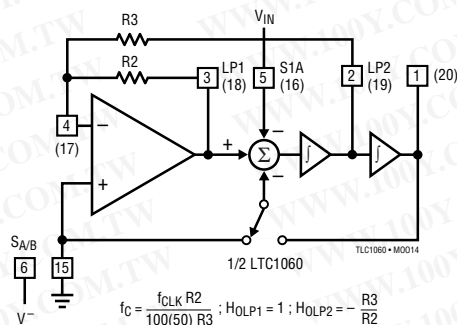

Figure 17. Mode 6b: 1st Order Filter Providing Lowpass

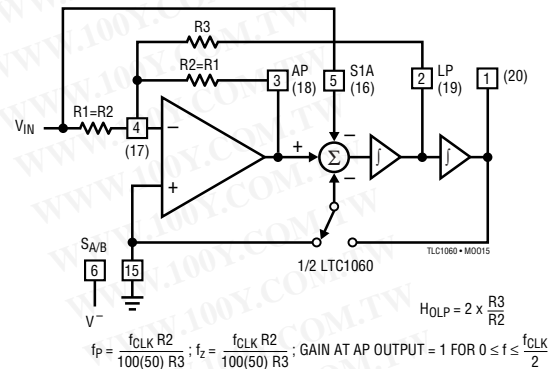

Figure 18. Mode 7: 1st Order Filter Providing Allpass, Lowpass

## COMMENTS ON THE MODES OF OPERATION

There are basically three modes of operation: mode 1, mode 2, mode 3. In the mode 1 (Figure 4), the input amplifier is outside the resonant loop. Because of this, mode 1 and its derivatives (mode 1a, 1b, 1c) are faster than modes 2 and 3. In mode 1, for instance, the Q errors are becoming noticeable above 1MHz clock frequency.

Mode 1a (Figure 5), represents the most simple hook-up of the LTC1060. Mode 1a is useful when voltage gain at the bandpass output is required. The bandpass voltage gain, however, is equal to the value of Q; if this is acceptable, a second order, clock tunable, BP resonator can be achieved with only 2 resistors. The filter center frequency directly depends on the external clock frequency. For high order filters, mode 1a is not practical since it may require several clock frequencies to tune the overall filter response.

Mode 1 (Figure 4), provides a clock tunable notch; the depth is shown in Graph 14. Mode 1 is a practical configuration for second order clock tunable bandpass/notch filters. In mode 1, a bandpass output with a very high Q, together with unity gain, can be obtained without creating problems with the dynamics of the remaining notch and lowpass outputs.

Modes 1b and 1c (Figures 6 and 7), are similar. They both produce a notch with a frequency which is always equal to the filter building block center frequency. The notch and the center frequency, however, can be adjusted with an external resistor ratio.

The practical clock-to-center frequency ratio range is:

$$\frac{500}{1} \geq \frac{f_{CLK}}{f_0} \geq \frac{100}{1} \left( \text{or } \frac{50}{1} \right); \text{ mode 1b}$$

$$\frac{100}{1} \text{ or } \frac{50}{1} \geq \frac{f_{CLK}}{f_0} \geq \frac{100}{\sqrt{2}} \text{ or } \frac{50}{\sqrt{2}}; \text{ mode 1c}$$

The input impedance of the S1 pin is clock dependent, and in general R5 should not be larger than 5k. Mode 1b can be used to increase the clock-to-center frequency ratio beyond 100:1. For this mode, a practical limit for the ( $f_{CLK}/f_0$ ) ratio is 500:1. Beyond this, the filter will exhibit large output offsets. Mode 1c is the fastest mode of operation: In the 50:1 mode and with ( $R5 = 0, R6 = \infty$ ) the clock-to-center frequency ratio becomes ( $50/\sqrt{2}$ ) and center frequencies beyond 20kHz can easily be achieved as shown in Graph 25. Figure 19 illustrates how to cascade the two sections of the LTC1060 connected in mode 1c to obtain a sharp fourth order, 1dB ripple, BP Chebyshev filter. Note that the center frequency to the BW ratio for this fourth order bandpass filter is 20/1. By varying the clock frequency to sweep the filter, the center frequency of the overall filter will increase proportionally and so will the BW to maintain the 20:1 ratio constant. All the modes of operation yield constant Q's; with any filter realization the BW's will vary when the filter is swept. This is shown in Figure 19, where the BP filter is swept from 1kHz to 20kHz center frequency.

## COMMENTS ON THE MODES OF OPERATION

Modes 2, 2a, and 2b have a notch output which frequency,  $f_n$ , can be tuned independently from the center frequency,  $f_0$ . For all cases, however,  $f_n < f_0$ . These modes are useful when cascading second order functions to create an

overall elliptic highpass, bandpass or notch response. The input amplifier and its feedback resistors ( $R_2/R_4$ ) are now part of the resonant loop. Because of this, mode 2 and its derivatives are slower than mode 1's.

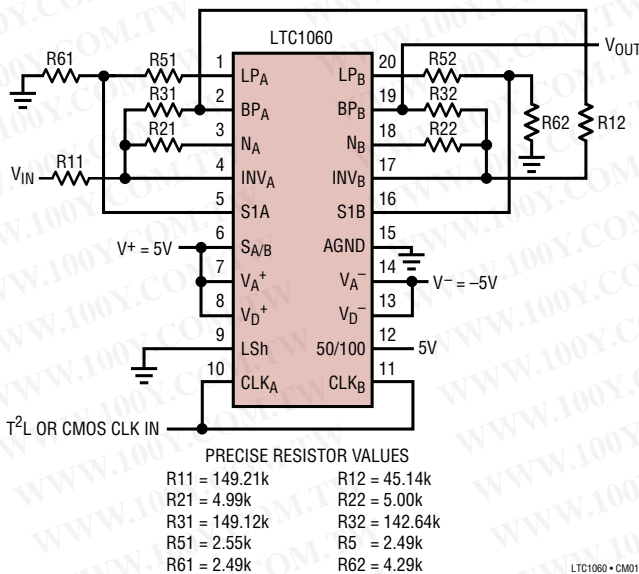

**Figure 19. Cascading the Two Sections of the LTC1060 Connected in Mode 1c to Obtain a Clock Tunable 4th Order 1dB Ripple Bandpass Chebyshev Filter with (Center Frequency)/(Ripple Bw) = 20/1.**

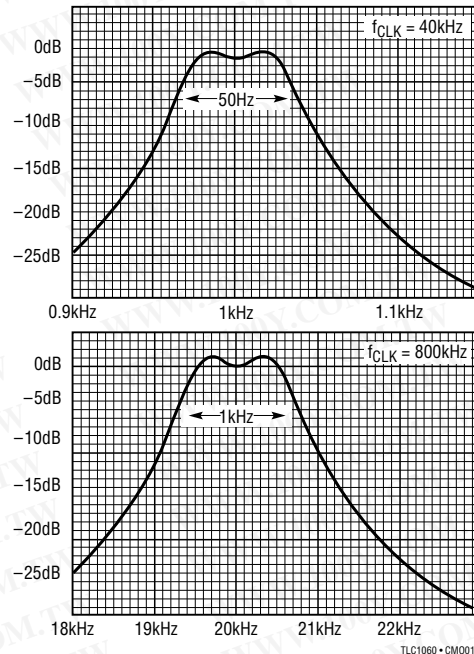

In mode 3 (Figure 11), a single resistor ratio ( $R_2/R_4$ ) can tune the center frequency below or above the  $f_{CLK}/100$  (or  $f_{CLK}/50$ ) ratio. Mode 3 is a state variable configuration since it provides a highpass, bandpass, lowpass output through progressive integration; notches are obtained by summing the highpass and lowpass outputs (mode 3a, Figure 12). The notch frequency can be tuned below or above the center frequency through the resistor ratio ( $R_h/R_i$ ). Because of this, modes 3 and 3a are the most versatile and useful modes for cascading second order sections to obtain high order elliptic filters. Figure 20 shows the two sections of an LTC1060 connected in mode 3a to obtain a clock tunable 4th order sharp elliptic bandpass filter. The first notch is created by summing directly the HP and LP outputs of the first section into the inverting input of the second section op amp. The individual Q's are 29.6 and the filter maintains its shape and performance up to 20kHz center frequency (Figure 21). For this circuit an external op amp is required to obtain the 2nd notch. The dynamics of Figure 20 are excellent be-

cause the amplitude response at each output pin does not exceed 0dB. The gain in the passband depends on the ratio of  $(R_g/R_{h2}) \cdot (R_{22}/R_{h1}) \cdot (R_{21}/R_{11})$ . Any gain value can be obtained by acting on the  $(R_g/R_{h2})$  ratio of the external op amp, meanwhile the remaining ratios are adjusted for optimum dynamics of the LTC1060 output nodes. The external op amp of Figure 20 is not always required. In Figure 22, one section of the LTC1060 in mode 3a is cascaded with the other section in mode 2b to obtain a 4th order, 1dB ripple, elliptic bandreject filter. This configuration is interesting because a 4th order function with two different notches is realized without requiring an external op amp. The clock-to-center frequency ratio is adjusted to 200:1; this is done in order to better approximate a linear R,C notch filter. The amplitude response of the filter is shown in Figure 23 with up to 1MHz clock frequency. The 0dB bandwidth to the stop bandwidth ratio is 9/1. When the filter is centered at 1kHz, it should theoretically have a 44dB rejection with a 50Hz stop bandwidth. For a more narrow filter than the above, the unused BP output of the

## COMMENTS ON THE MODES OF OPERATION

mode 2b section (Figure 22), has a gain exceeding unity which limits the dynamic range of the overall filter. For very selective bandpass/bandreject filters, the mode 3a

approach, as in Figure 20, yields better dynamic range since the external op amp helps to optimize the dynamics of the output nodes of the LTC1060.

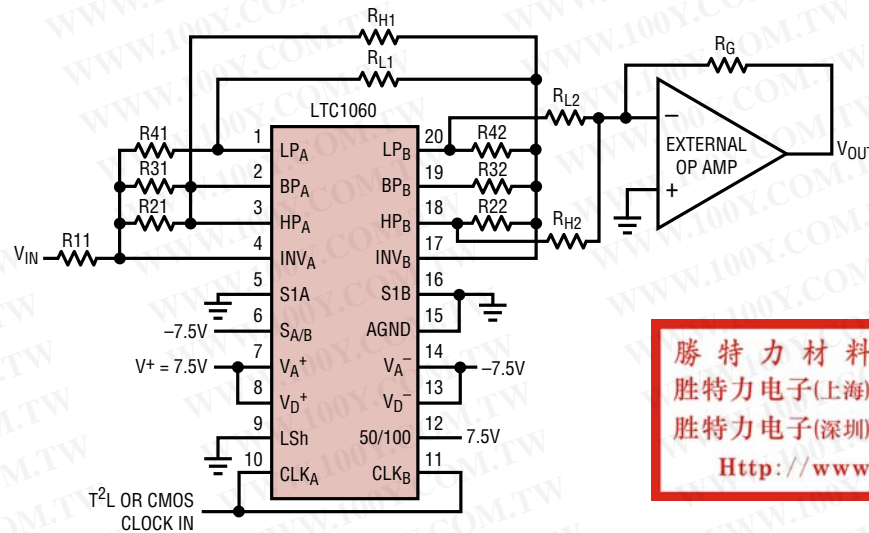

**勝特力材料 886-3-5753170**  
**勝特力电子(上海) 86-21-34970699**  
**勝特力电子(深圳) 86-755-83298787**  
[Http://www.100y.com.tw](http://www.100y.com.tw)

PRECISE RESISTOR VALUES

R11 = 155.93k	R21 = 5k	R31 = 152k	R41 = 5.27k
RH1 = 13.2k	RL1 = 10.74k	R22 = 5.26k	R32 = 151.8k
R42 = 5k	RL2 = 6.11k	RH2 = 5k	RG = 37.3k

NOTE: FOR CLOCK FREQUENCIES ABOVE 700kHz, A 12pF CAPACITOR ACROSS R41 AND A 20pF CAPACITOR ACROSS R42 WERE USED TO PREVENT THE PASSBAND RIPPLE FROM ANY ADDITIONAL PEAKING

LTC1060 • CM02

**Figure 20. Combining Mode 3 with Mode 3a to Make The 4th Order BP Filter of Figure 21 with Improved Dynamics. The Gain at Each Output Node is ≤ 0dB for all Input Frequencies.**

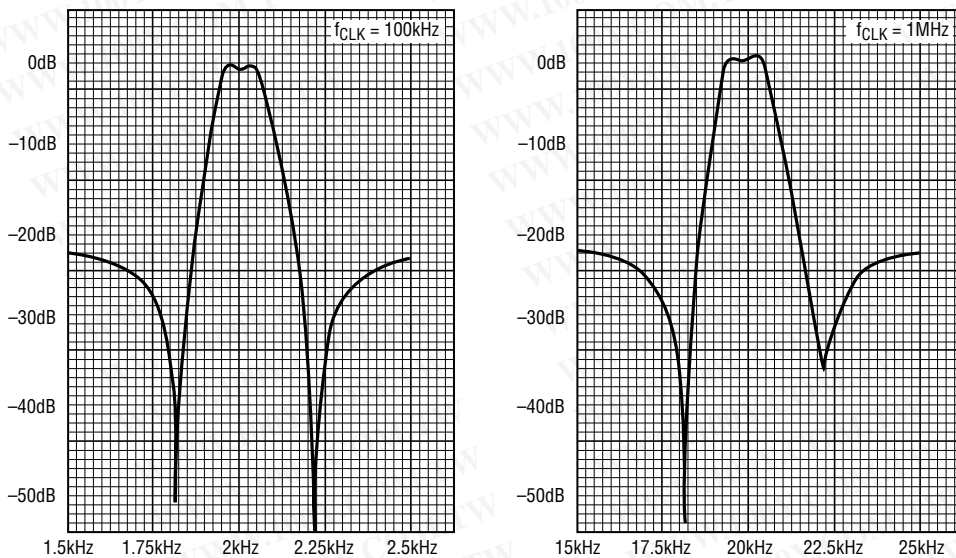

TLC1060 • CM003

**Figure 21. The BP Filter of Figure 20, When Swept From a 2kHz to 20kHz Center Frequency.**

COMMENTS ON THE MODES OF OPERATION

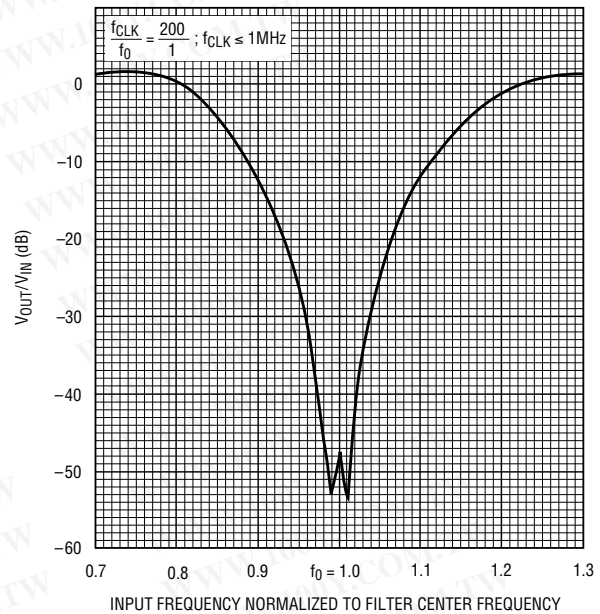
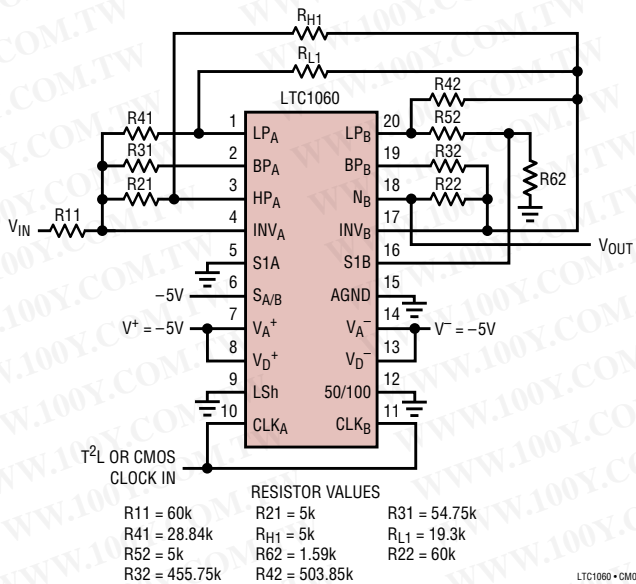

Figure 22. Combining Mode 3 with Mode 2b to Create a 4th Order BR Elliptic Filter with 1dB Ripple and a Ratio of 0dB to Stop Bandwidth Equal to 9/1.

Figure 23. Amplitude Response of the Notch Filter of Figure 22

LTC1060 OFFSETS

Switched capacitor integrators generally exhibit higher input offsets than discrete R, C integrators. These offsets are mainly due to the charge injection of the CMOS switches into the integrating capacitors and they are temperature independent.

The internal op amp offsets also add to the overall offset budget and they are typically a couple of millivolts. Because of this, the DC output offsets of switched capacitor filters are usually higher than the offsets of discrete active filters.

Figure 24 shows half of an LTC1060 filter building block with its equivalent input offsets  $V_{OS1}$ ,  $V_{OS2}$ ,  $V_{OS3}$ . All three are 100% tested for both sides of the LTC1060.  $V_{OS2}$  is generally the larger offset. When the  $S_{A/B}$ , Pin 6, of the LTC1060 is shorted to the negative supply (i.e., mode 3), the value of the  $V_{OS2}$  decreases. Additionally, with  $S_{A/B}$  low, a 20% to 30% noise reduction is observed. Mode 1 can still be achieved, if desired, by shorting the S1 pin to the lowpass output (Figure 25).

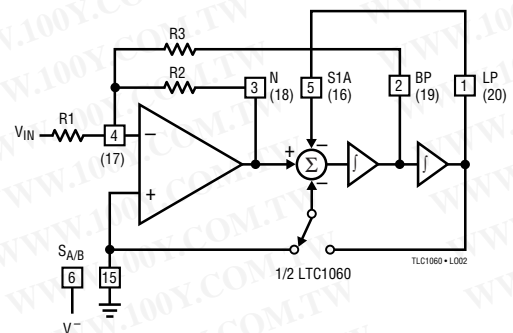
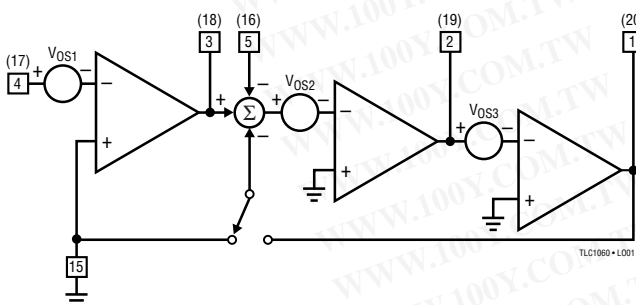

Figure 24. Equivalent Input Offsets of 1/2 LTC1060 Filter Building Block

Figure 25. Mode 1(LN): Same Operation as Mode 1 but Lower  $V_{OS2}$  Offset and Lower Noise

## LTC1060 OFFSETS

### Output Offsets

The DC offset at the filter bandpass output is always equal to  $V_{OS3}$ . The DC offsets at the remaining two outputs (Notch and LP) depend on the mode of operation and external resistor ratios. Table 5 illustrates this.

It is important to know the value of the DC output offsets, especially when the filter handles input signals with large

dynamic range. As a rule of thumb, the output DC offsets increase when:

1. The Q's decrease.
2. The ratio ( $f_{CLK}/f_0$ ) increases beyond 100:1. This is done by decreasing either the ( $R2/R4$ ) or the  $R6/(R5 + R6)$  resistor ratios.

Table 5

MODE	$V_{OSN}$ PIN 3 (18)	$V_{OSBP}$ PIN 2 (19)	$V_{OSLP}$ PIN 1 (20)
1,4	$V_{OS1} [(1/Q) + 1 +   H_{OLP}  ] - V_{OS3}/Q$	$V_{OS3}$	$V_{OSN} - V_{OS2}$
1a	$V_{OS1} [1 + (1/Q)] - V_{OS3}/Q$	$V_{OS3}$	$V_{OSN} - V_{OS2}$
1b	$V_{OS1} [(1/Q) + 1 + R2/R1] - V_{OS3}/Q$	$V_{OS3}$	$\sim (V_{OSN} - V_{OS2}) (1 + R5/R6)$
1c	$V_{OS1} [(1/Q) + 1 + R2/R1] - V_{OS3}/Q$	$V_{OS3}$	$\sim (V_{OSN} - V_{OS2}) \frac{(R5 + R6)}{(R5 + 2R6)}$
2, 5	$[V_{OS1}(1 + R2/R1 + R2/R3 + R2/R4) - V_{OS3}(R2/R3)]$ • $[R4/(R2 + R4) + V_{OS2}(R2/(R2 + R4))]$	$V_{OS3}$	$V_{OSN} - V_{OS2}$
2a	$[V_{OS1}(1 + R2/R1 + R2/R3 + R2/R4) - V_{OS3}(R2/R3)]$ • $\left[ \frac{R4(1+k)}{R2 + R4(1+k)} + V_{OS2} \left[ \frac{R2}{R2 + R4(1+k)} \right] \right]; k = \frac{R6}{R5 + R6}$	$V_{OS3}$	$\sim (V_{OSN} - V_{OS2}) \frac{(R5 + R6)}{(R5 + 2R6)}$
2b	$[V_{OS1}(1 + R2/R1 + R2/R3 + R2/R4) - V_{OS3}(R2/R3)]$ • $\left[ \frac{R4k}{R2 + R4k} + V_{OS2} \left[ \frac{R2}{R2 + R4k} \right] \right]; k = \frac{R6}{R5 + R6}$	$V_{OS3}$	$\sim (V_{OSN} - V_{OS2}) (1 + R5/R6)$
3, 4a	$V_{OS2}$	$V_{OS3}$	$V_{OS1} \left[ 1 + \frac{R4}{R1} + \frac{R4}{R2} + \frac{R4}{R3} \right] - V_{OS2} \left( \frac{R4}{R2} \right)$ $- V_{OS3} \left( \frac{R4}{R3} \right)$

## PACKAGE DESCRIPTION

### N Package 20-Lead PDIP (Narrow .300 Inch) (Reference LTC DWG # 05-08-1510)

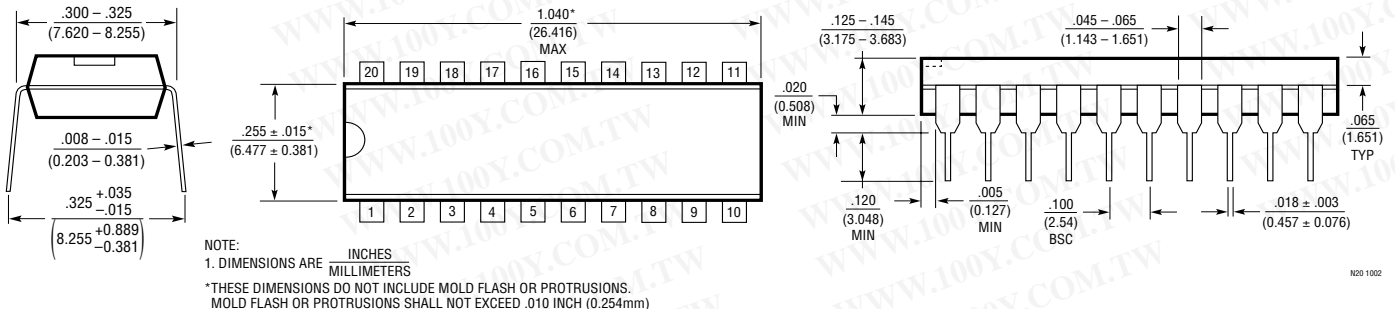

**PACKAGE DESCRIPTION**

