



勝特力材料 886-3-5753170  
勝特力电子(上海) 86-21-34970699  
勝特力电子(深圳) 86-755-83298787  
[Http://www.100y.com.tw](http://www.100y.com.tw)

## 一、產品圖面/尺寸 (Drawings and Dimensions)

尺寸 DIMENSIONS

(單位 UNIT : mm)



ROTATION DIRECTION: COUNTER-CLOCKWISE

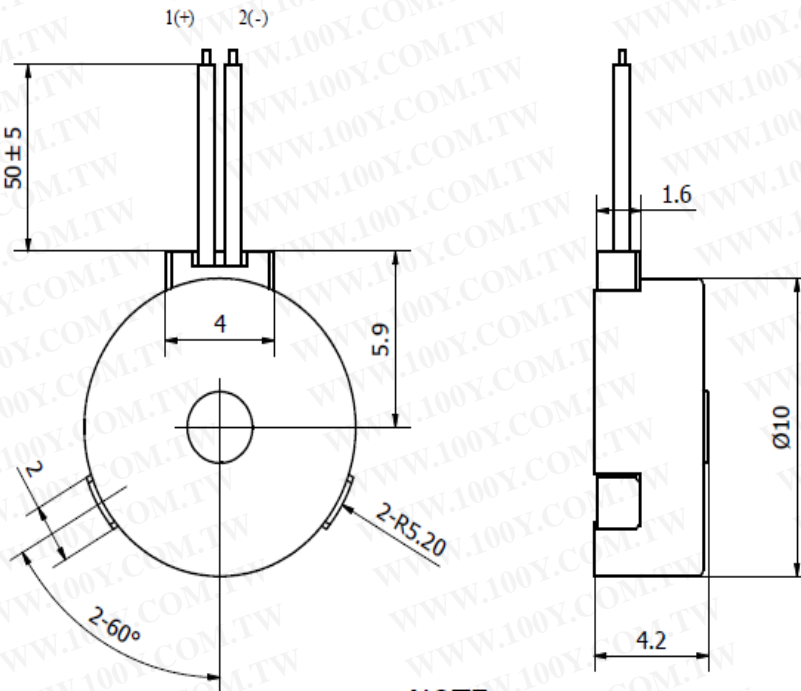

NOTE

WIRE:UL1571 AWG#32

LINE1:RED WIRE----- (+)

LINE2:BLACK WIRE----- (-)



9001 : 2015

## 二、產品規格/特性 (Specification and Features)

### 規格 SPECIFICATIONS

型號 Model Number	RVN1004
品名 Product Name	無刷振動馬達 Brushless Vibration Motor
額定電壓 Rated Voltage (VDC)	3.0
運轉電壓 Operating Voltage (VDC)	2.8 ~ 3.3
額定電流 Rated Current (mA)	48 (max:55)
轉速 Rotation Speed (RPM)	7,000 ~ 9,000
振動強度 Vibration Intensity ( $m/s^2$ )	5.0 ~ 11.8 MAX.
負載重量 Load Mass (g)	25 ~ 100
絕緣強度 Insulation Resistance	10MEGA. $\Omega$ Min. at 500VDC (between housing and (+) terminal)
耐壓強度 Dielectric Strength	5mA Max. at 500VAC、60Hz、One Minute (between housing and (+) terminal)
重量 Weight (g)	1.1
認證 Compliance	CE、RoHS
防水防塵 IP rating	IP57

\*規格視實際情況更動不作另行通知。Specifications subject to changes without notice.

\*\*運作環境溫度 Operating Temperature :  $-20^{\circ}\text{C} \sim +70^{\circ}\text{C}$

### 性能曲線 PERFORMANCE CURVE

RVN1004 (3V)

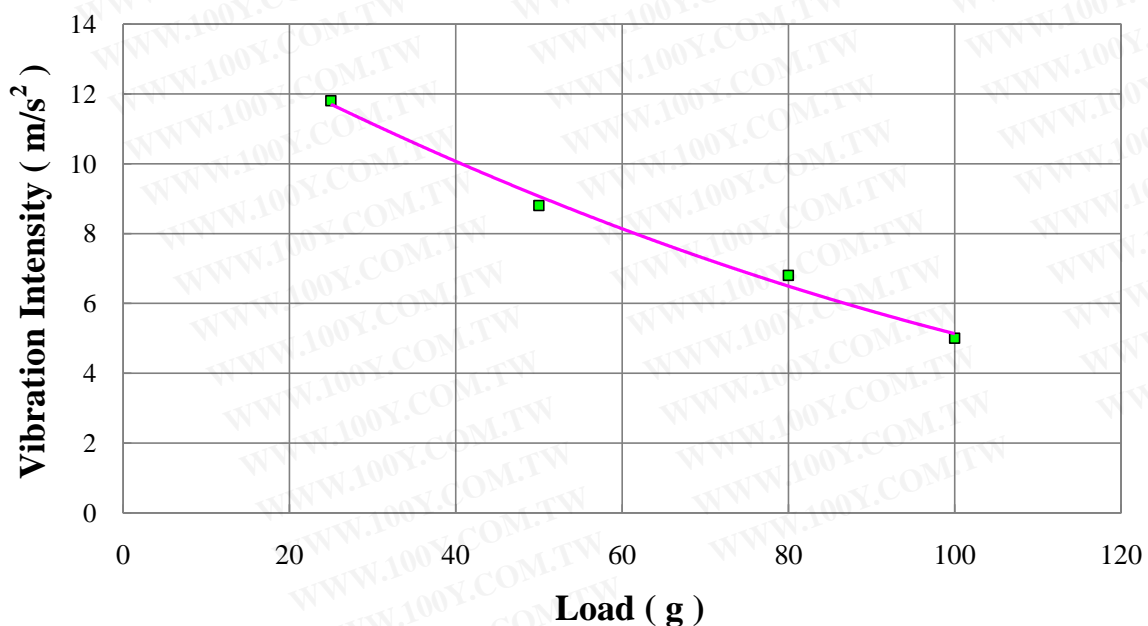

## 振動量量測 VIBRATION MEASUREMENT

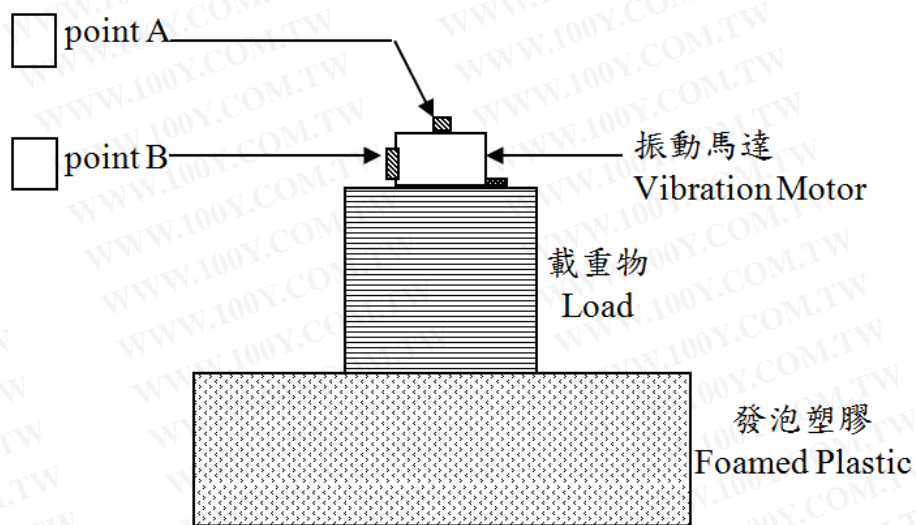

1. 載重物質質量為 25~100 克。The mass of the load ranges from 25g to 100g.
2. 載重物材質為 Al 6061。The material of the load is Al 6061.
3. 量測方式：將待測振動馬達黏貼於載重物上，載重物置於發泡塑膠墊之上，然後以加速規量測馬達本體上 A 點或 B 點的加速度值。

The vibration motor under test is attached to a load on foam plastic, and the measurement is taken at point A or B via an accelerometer.

4. 振動量強度係以加速度表示，單位為  $m/s^2$  或  $G$  ( $=9.8 m/s^2$ )。

Vibration intensity is expressed in terms of acceleration with the unit of  $m/s^2$  or  $G$ , which equals to  $9.8 m/s^2$ .