



Analog Output Module Catalog Number 1771-OFE Series B

Contents



This icon is used when additional information is available in the *Analog Output Module User Manual*, publication 1771-UM030.

勝特力材料 886-3-5753170
勝特力电子(上海) 86-21-34970699
勝特力电子(深圳) 86-755-83298787
[Http://www.100y.com.tw](http://www.100y.com.tw)

Important User Information

Use this document as a guide when installing the 1771-OFE analog output module.

To	See page
↓ Important User Information	1
↓ Understand Product Compatibility	4
↓ Calculate Power Requirements	4
↓ Determine Module Placement	5
↓ Set the Module Configuration Jumpers	5
↓ Install the Keying Bands	8
↓ Install the Module and Field Wiring Arm	9
↓ Connect Wiring to the Field Wiring Arm	10
↓ Ground the Chassis and Module	11
↓ Configure the Module	12
For this reference information	
➡ Diagnostics and Troubleshooting	13
➡ Hazardous Locations	15
➡ Specifications	16

Because of the variety of uses for the products described in this publication, those responsible for the application and use of these products must satisfy themselves that all necessary steps have been taken to assure that each application and use meets all performance and safety requirements, including any applicable laws, regulations, codes and standards. In no event will Rockwell Automation be responsible or liable for indirect or consequential damage resulting from the use or application of these products.

Any illustrations, charts, sample programs, and layout examples shown in this publication are intended solely for purposes of example. Since there are many variables and requirements associated with any particular installation, Rockwell Automation does not assume responsibility or liability (to include intellectual property liability) for actual use based upon the examples shown in this publication.

Allen–Bradley publication SGI–1.1, Safety Guidelines for Application, Installation, and Maintenance of Solid–State Control (available from your local Rockwell Automation office), describes some important differences between solid–state equipment and electromechanical devices that should be taken into consideration when applying products such as those described in this publication.

Reproduction of the contents of this copyrighted publication, in whole or part, without written permission of Rockwell Automation, is prohibited.

Throughout this publication, notes may be used to make you aware of safety considerations. The following annotations and their accompanying statements help you to identify a potential hazard, avoid a potential hazard, and recognize the consequences of a potential hazard.

WARNING

Identifies information about practices or circumstances that can cause an explosion in a hazardous environment, which may lead to personal injury or death, property damage, or economic loss.

ATTENTION

Identifies information about practices or circumstances that may lead to personal injury or death, property damage, or economic loss.

IMPORTANT

Identifies information that is critical for successful application and understanding of the product.

ATTENTION**Environment and Enclosure**

This equipment is intended for use in a Pollution Degree 2 industrial environment, in overvoltage Category II applications (as defined in IEC publication 60664–1), at altitudes up to 2000 meters without derating.

This equipment is considered Group 1, Class A industrial equipment according to IEC/CISPR Publication 11. Without appropriate precautions, there may be potential difficulties ensuring electromagnetic compatibility in other environments due to conducted as well as radiated disturbance.

This equipment is supplied as “open type” equipment. It must be mounted within an enclosure that is suitably designed for those specific environmental conditions that will be present, and appropriately designed to prevent personal injury resulting from accessibility to live parts. The interior of the enclosure must be accessible only by the use of a tool. Subsequent sections of this publication may contain additional information regarding specific enclosure type ratings that are required to comply with certain product safety certifications.

See NEMA Standards publication 250 and IEC publication 60529, as applicable, for explanations of the degrees of protection provided by different types of enclosures. Also, see the appropriate sections in this publication, as well as the Allen–Bradley publication 1770–4.1, (“Industrial Automation Wiring and Grounding Guidelines”), for additional installation requirements pertaining to this equipment.

ATTENTION**Preventing Electrostatic Discharge**

This equipment is sensitive to electrostatic discharge, which can cause internal damage and affect normal operation. Follow these guidelines when you handle this equipment:

- Touch a grounded object to discharge potential static.
- Wear an approved grounding wriststrap.
- Do not touch connectors or pins on component boards.
- Do not touch circuit components inside the equipment.
- If available, use a static-safe workstation.
- When not in use, keep modules in appropriate static-safe packaging.

Understand Product Compatibility

The 1771-OFE module can be used with any 1771 I/O chassis. Compatibility and data table use is listed below.

Catalog Number	Use of Data Table				Compatibility			
	Input Image Bits	Output Image Bits	Read Block Words	Write Block Words	Addressing			Chassis Series
					1/2-Slot	1-Slot	2-Slot	
1771-OFE/B	8	8	5	13	Y	Y	Y	A, B

A = Compatible with 1771-A1, -A2, -A4
 B = Compatible with 1771-A1B, -A2B, -A3B, -A3B1, -A4B
 Y = Compatible without restriction.

Calculate Power Requirements

The analog output module receives its power through the 1771 I/O chassis backplane from the chassis power supply. It does not require any other external power supply. When planning your system, you must consider the power usage of all modules in the I/O chassis to prevent overloading the I/O chassis backplane and/or power supply. Add this to the requirements of all other modules in the I/O chassis.

Analog Module	Power Requirement
1771-OFE1	1.5A @ 5V dc
1771-OFE2	
1771-OFE3	2.5A @ 5V dc

Determine Module Placement in the I/O Chassis

Place your module in any I/O module slot of the I/O chassis except for the left-most slot. This slot is reserved for PC processors or adapter modules.

ATTENTION



Group your modules to minimize adverse affects from radiated electrical noise and heat. We recommend the following.

- Group analog output and low voltage dc modules away from ac modules or high voltage dc modules to minimize electrical noise interference.
- Do not place this module in the same I/O group with a discrete high-density I/O module when using 2-slot addressing.
- Limit adjacent slot power dissipation to 10W maximum.

Set the Module Configuration Jumpers

The module configuration jumpers consist of:

- the last state configuration jumper (all versions)
- the voltage range configuration jumpers (1771-OFE1 only).

The type of module you have dictates how you set the configuration jumpers.

There are three versions of the analog output module:

Catalog Number	Module Output	Output Range	
1771-OFE1	Voltage	1-5V dc 0-10V dc $\pm 10V$ dc	Selected by configuration jumpers
1771-OFE2	Current	4-20mA	Factory set
1771-OFE3	Current	0-50mA	Factory set

Current Output Versions of the Module

Current version modules (1771-OFE2 and -OFE3) have all configuration jumpers installed and require no additional configuration. The configuration jumper for the LAST STATE mode output level is in the default position (MID). Refer to the section entitled “Set the Last State Configuration Jumpers” for additional configuration information.

Voltage Output Version of the Module

If you are using the voltage output version (1771-OFE1), you must set several configuration jumpers on the module's circuit board. You must set these jumpers before you can proceed with configuring the module. When you set these jumpers, you configure each channel for one of the three voltage ranges listed above. **The module is shipped with the jumpers in the $\pm 10V$ position.**

Set the Last State Configuration Jumpers

The LAST STATE configuration jumpers determine the value of all the module's outputs whenever communication between the module and the processor is lost. This condition occurs when a processor or adapter faults, or the processor is placed in the PROG or TEST mode, or if the remote I/O cable breaks.

This is a significant safety feature. You can choose to have the module's outputs go to the minimum, middle or maximum of their respective ranges or hold their last state if a module or system fault occurs or if the system processor changes from RUN to PROG mode.

You do this by placing the LAST STATE configuration jumpers on eight (four jumpers on sets of pins) of the stake pins corresponding to MIN, MID or MAX. If you do not place configuration jumpers in one of these positions, the module defaults to the HOLD LAST VALUE setting.

IMPORTANT

- On power-up, the module's output is disabled until the module receives the first block transfer write. The output then enables with the value that you send it in the block transfer write block.
- We ship 1771-OFE modules with the LAST STATE configuration jumpers in the MID position.

ATTENTION



Switch 1 of the I/O rack affects the function of the configuration settings as indicated in the table below.

Rack Switch 1 Setting	Configuration Jumper Setting			
	MIN	MID	MAX	HOLD LAST STATE
Last State	Last State	Last State	Last State	Last State
Reset	Min	Mid	Max	Last State

Rack switch 1 determines what output conditions occur during a rack fault.

To set the last state configuration jumpers, proceed as follows.

ATTENTION



Do not insert modules into or remove modules from the I/O chassis while system power is ON. Failure to observe this rule could result in damage to module circuitry and unexpected machine operation.

Output Range Selection	Minimum Value	Middle Value	Maximum Value
4-20mA	4mA	12mA	20mA
0-50mA	0mA	25mA	50mA
1-5V	1V	3V	5V
0-10V	0V	5V	10V
±10V	-10V	0V	+10V

These output conditions are active **only** if the following conditions exist:

- the module faults
- the processor is in the PROGRAM or TEST mode
- rack switch 1 is in the reset position

- 1 Locate the last state configuration jumpers. You do not need to remove the module cover.

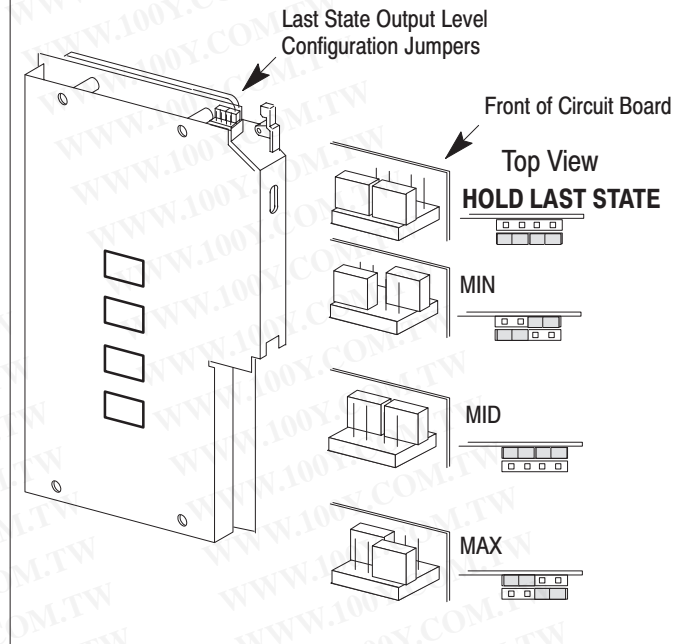

- 2 Carefully pull up on the jumper to remove it from the pins.

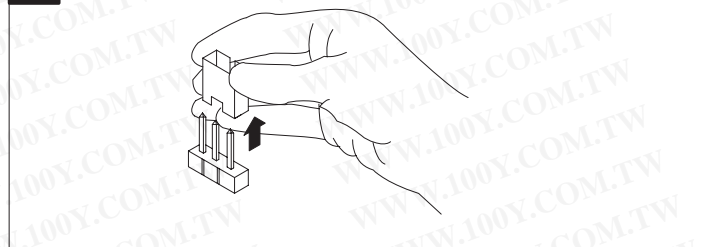

- 3 Carefully reposition the jumper to reflect the desired values in the table to the left.

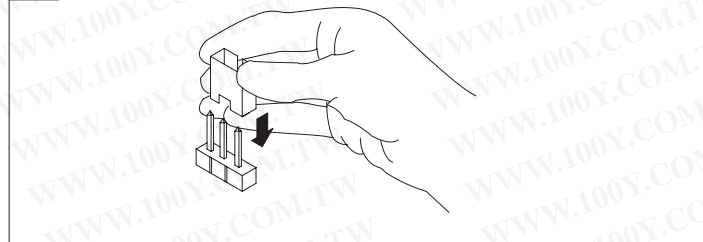

Set the Voltage Range Configuration Jumpers (1771-OFE1 only)

If you ordered the voltage output version, you must set several configuration jumpers located inside the module on the circuit board.

2

Locate the configuration jumpers and set them according to your output voltage requirements.

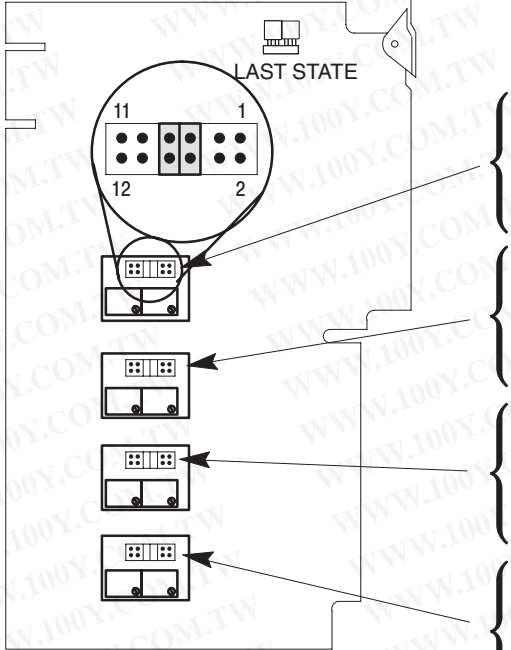

Configuration Jumper Location	Desired Voltage Range			Output Channel
	0-10V	$\pm 10V$	1-5V	
P3, Jumper	11-12	In	Out	1
	9-10	In	Out	
	7-8	Out	In	
	5-6	Out	In	
	3-4	Out	Out	
	1-2	Out	Out	
P5, Jumper	11-12	In	Out	2
	9-10	In	Out	
	7-8	Out	In	
	5-6	Out	In	
	3-4	Out	Out	
	1-2	Out	Out	
P7, Jumper	11-12	In	Out	3
	9-10	In	Out	
	7-8	Out	In	
	5-6	Out	In	
	3-4	Out	Out	
	1-2	Out	Out	
P9, Jumper	11-12	In	Out	4
	9-10	In	Out	
	7-8	Out	In	
	5-6	Out	In	
	3-4	Out	Out	
	1-2	Out	Out	

(side view of jumper)

Install the Keying Bands

ATTENTION



Observe the following precautions when inserting or removing keys:

- Insert or remove keys with your fingers.
- Make sure the key placement is correct

Incorrect keying or the use of a tool can result in damage to the backplane connector and possible system faults.

Position the keying bands in the backplane connectors to correspond to the key slots on the module.

Place the keying bands:
between 10 and 12
between 26 and 28

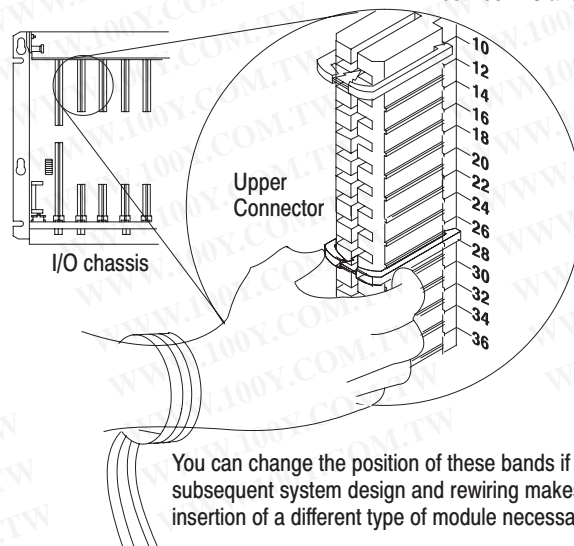

Install the Module and Field Wiring Arm

ATTENTION



Remove power from the 1771 I/O chassis backplane and field wiring arm before removing or installing an I/O module.

- Failure to remove power from the backplane or wiring arm could cause module damage, degradation of performance, or injury.
- Failure to remove power from the backplane could cause injury or equipment damage due to possible unexpected operation.

WARNING



When you insert or remove the module with power applied, or connect or disconnect the field wiring arm with field side power applied, an electrical arc can occur. This could cause an explosion in hazardous location installations.

Be sure that power is removed or the area is nonhazardous before proceeding.

1

Attach the wiring arm (1771-WC) to the horizontal bar at the bottom of the I/O chassis.

The wiring arm pivots upward and connects with the module so you can install or remove the module without disconnecting the wires.

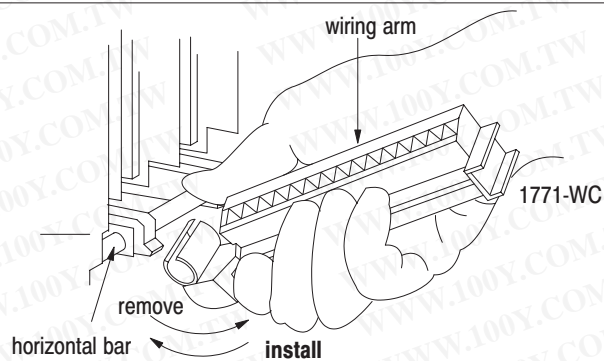

17643

2

1771-A1B, -A2B, -A3B, -A3B1, -A4B I/O chassis

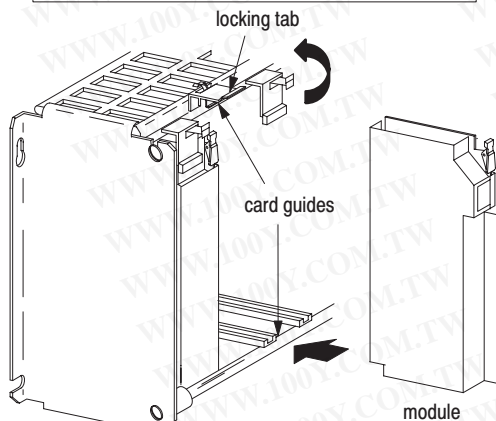

Snap the chassis latch over the top of the module to secure it.

1771-A1B, -A2B, -A3B1, -A4B Series B I/O chassis

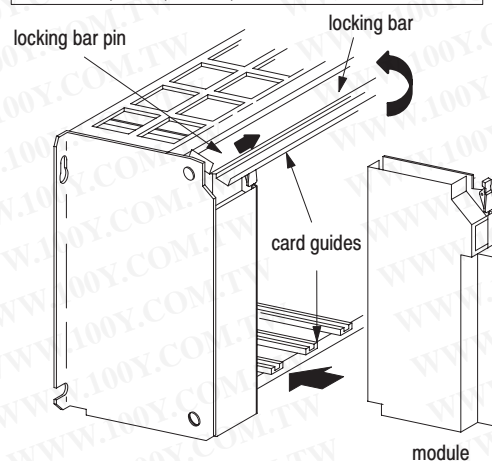

Swing the chassis locking bar down into place to secure the modules. Make sure the locking pins engage.

19809

The 1771-OFE modules are a modular component of the 1771 I/O system requiring a properly installed system chassis. Refer to publication 1771-IN075 for detailed information on acceptable chassis and proper installation and grounding requirements. Limit the maximum adjacent slot power dissipation to 10W maximum.

Connect Wiring to the Field Wiring Arm

Connect your I/O devices to the cat. no. 1771-WC wiring arm shipped with the module.

ATTENTION



Remove power from the 1771 I/O chassis backplane and field wiring arm before removing or installing an I/O module.

- Failure to remove power from the backplane or wiring arm could cause module damage, degradation of performance, or injury.
- Failure to remove power from the backplane could cause injury or equipment damage due to possible unexpected operation.

WARNING



If you connect or disconnect wiring with field-side power is on, an electrical arc can occur. This could cause an explosion in hazardous location installations. Be sure that power is removed or the area is nonhazardous before proceeding.

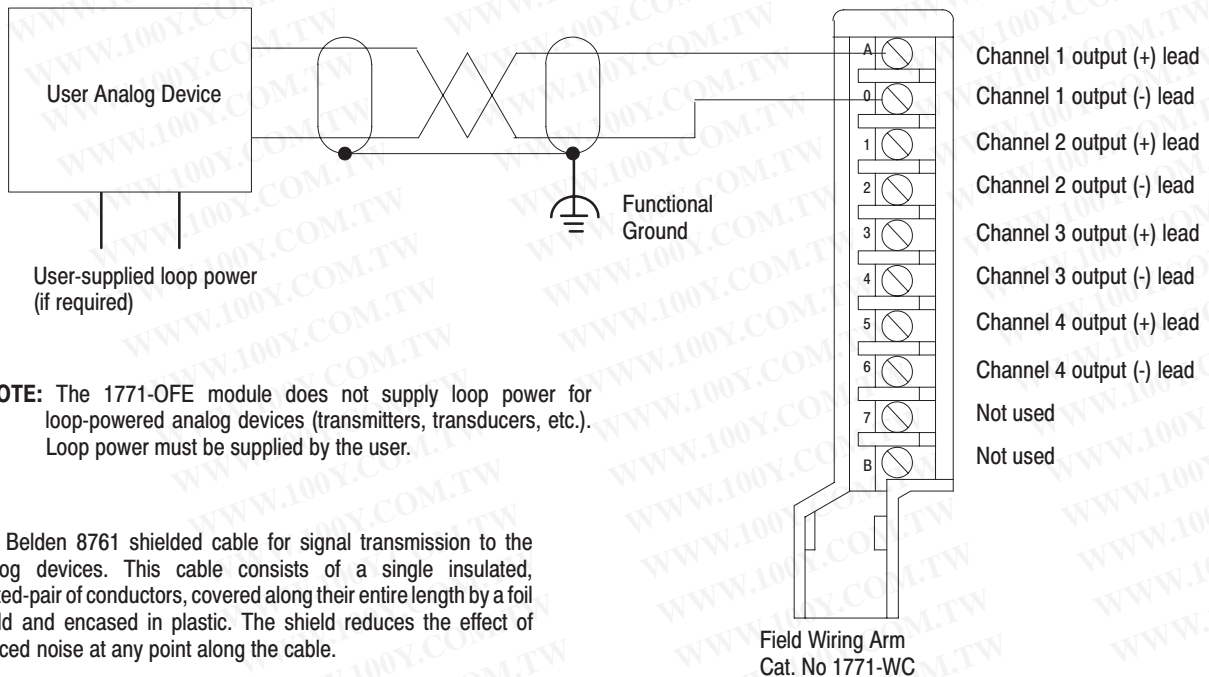

NOTE: The 1771-OFE module does not supply loop power for loop-powered analog devices (transmitters, transducers, etc.). Loop power must be supplied by the user.

Use Belden 8761 shielded cable for signal transmission to the analog devices. This cable consists of a single insulated, twisted-pair of conductors, covered along their entire length by a foil shield and encased in plastic. The shield reduces the effect of induced noise at any point along the cable.

Ground the Chassis and Module

Use the following diagrams to ground your I/O chassis and analog input module. Follow these steps to prepare the cable:

- 1 Remove a length of cable jacket from the Belden 8761 cable.



- 2 Pull the foil shield and bare drain wire from the insulated wires.

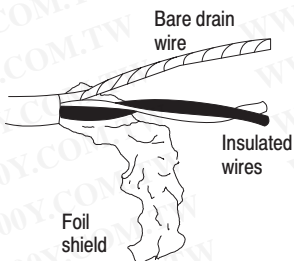

- 3 Twist the foil shield and drain wire together to form a single strand.



- 4 Attach a ground lug.



When using shielded cable wire, ground the foil shield and drain wire only at one end of the cable. We recommend that you wrap the foil shield and drain wire together and connect them to a chassis mounting bolt.

At the opposite end of the cable, tape exposed shield and drain wire with electrical tape to insulate it from electrical contact.

Refer to *Wiring and Grounding Guidelines*, publication 1770-4.1 for additional information.

Chassis Ground

When you connect grounding conductors to the I/O chassis grounding stud, place a star washer under the first lug, then place a nut with captive lock washer on top of each ground lug. Torque the nut with captive washer to 18(±3) pound-inches.

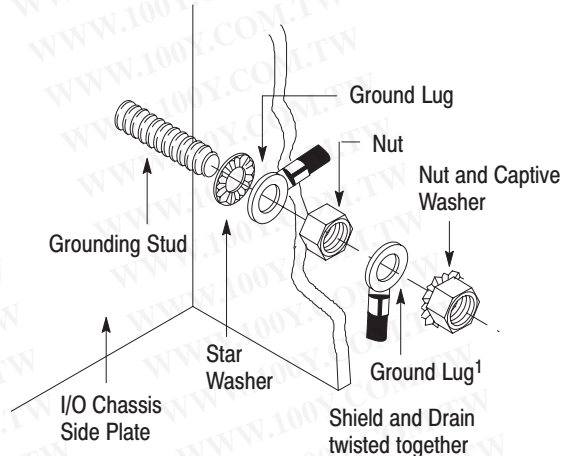

¹Use the cup washer if crimp-on lugs are not used.

Single-point Grounding

Extend shield to termination point. Expose just enough cable to adequately terminate inner conductors.

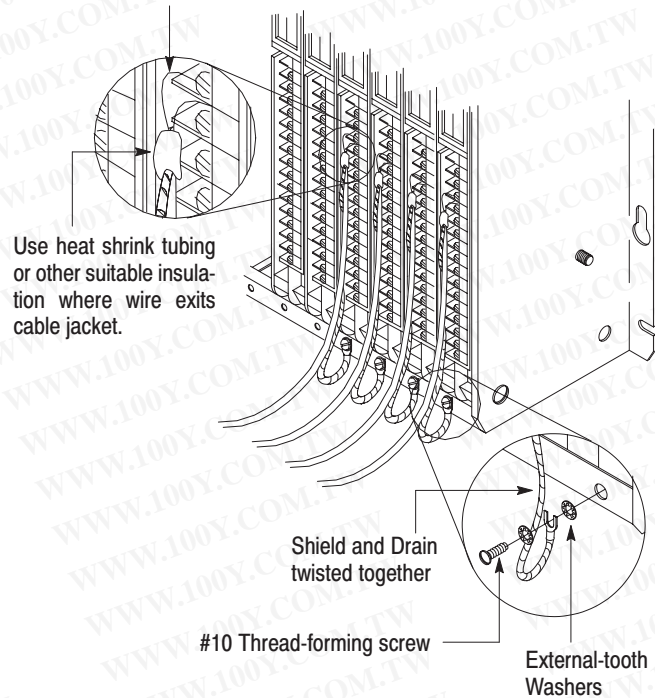

Configure the Module



For detailed configuration information, see chapter 2 of your *Analog Output User Manual* (publication 1771-UM030).

Because of the many analog devices available and the wide variety of possible applications, you must configure the module to conform to the analog device and specific application that you have chosen. Use the configuration information below to configure your module to your specifications.

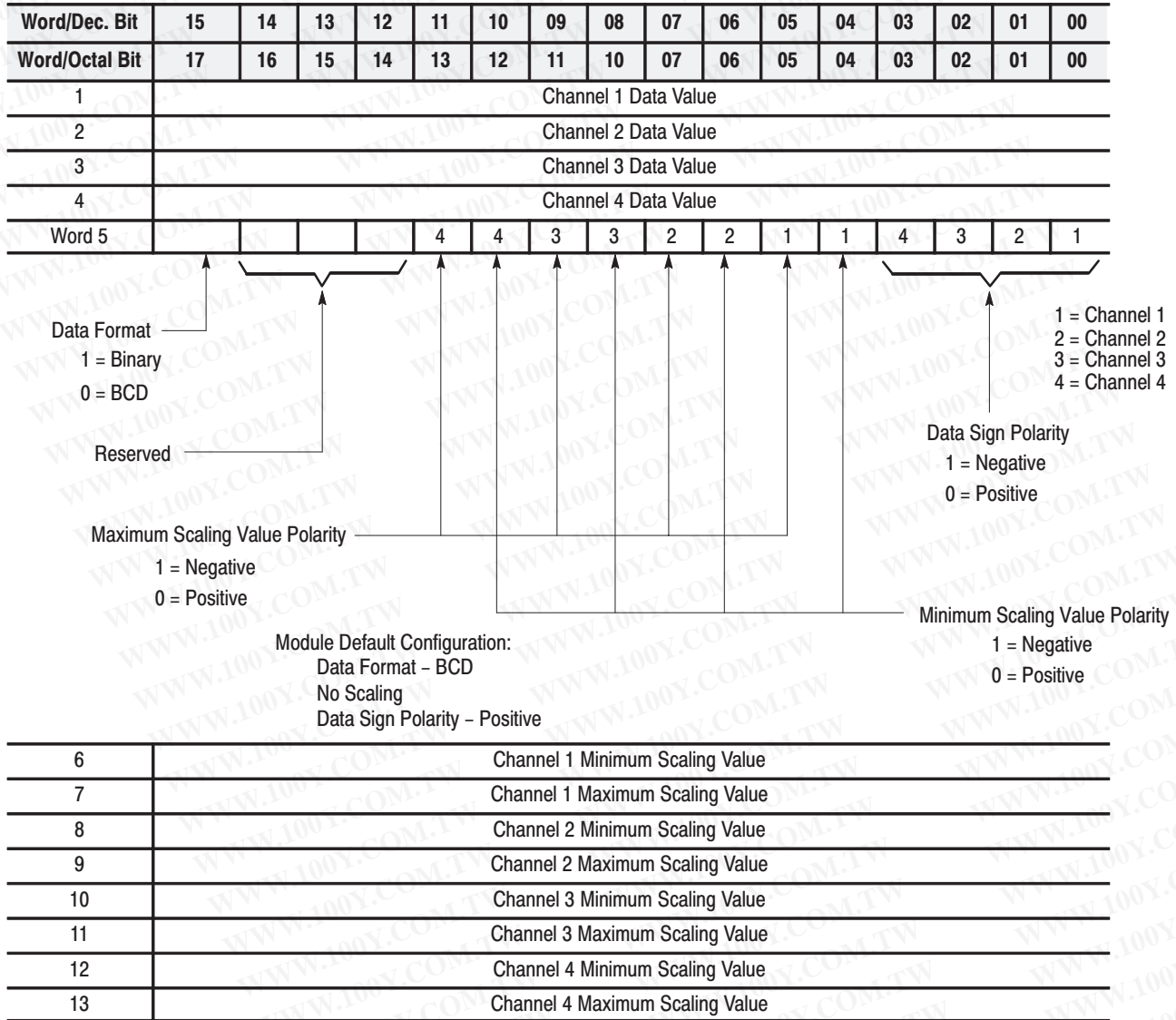

Diagnostics and Troubleshooting

The front panel of the module contains a green RUN and a red FLT (fault) indicator. Possible module fault causes and corrective actions are shown in the table below.

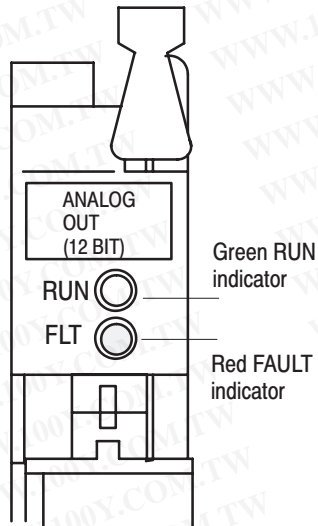

Indicators	Probable Cause	Recommended Action
RUN (green on) FLT (red off)	1. Awaiting configuration BTW 2. Normal operation	1. At power-up, the module output is disabled until the module receives the first BTW. The output is enabled and goes to the value sent in the BTW (normal operation). 2. None
RUN (green on) FLT (red on)	Unsuccessful power-up EEPROM fault Checksum error Hardware failure in module	Cycle power Return module for repair
RUN (green off) FLT (red off)	No power Bad internal fuse	Turn off power. Remove and reinsert module into chassis. Return power. If problem still exists, and chassis power supply is functioning properly, return the module for repair.

Read Block Transfer Status Words

The module allows a five-word read block transfer for rudimentary program or hardware debugging. If a read block transfer request is for more or less than five words, the module will not perform a read block transfer. The following table shows the word assignment for the read block transfer.

Decimal Bit	15	14	13	12	11	10	09	08	07	06	05	04	03	02	01	00
Octal Bit	17	16	15	14	13	12	11	10	07	06	05	04	03	02	01	00
Word 1	Channel 1 DAC Input Data															
2	Channel 2 DAC Input Data															
3	Channel 3 DAC Input Data															
4	Channel 4 DAC Input Data															
5	Not used	I/O Reset	Reserved										Data Valid			

The first four words of the read block transfer show the actual 12 bits of data sent to the module's digital-to-analog converters (DACs).

The first four words in the read block transfer appear in 12-bit binary format regardless of the module's mode of operation (BCD or 12-bit binary).

The fifth word contains the status of each DAC word; that is, whether data is out of range or scaling is improperly programmed. The fifth word also indicates that I/O RESET has been established (when the processor is in the PROG/TEST or RUN mode).

Word	Bits	Description
5	Bits 00-03	When set, indicate invalid channel data is sent to the module. These bits are not reset until a correct write block transfer is sent. Bit 03 corresponds to Channel 4, Bit 02 to Channel 3, and so on.
	Bit 16	Is the I/O RESET bit. When set, it indicates that the processor is in TEST or PROGRAM mode (i.e., block transfer data is not being written to the module).

Hazardous Locations

The following information applies when operating this equipment in hazardous locations:

Products marked “CL I, DIV 2, GP A, B, C, D” are suitable for use in Class I Division 2 Groups A, B, C, and D Hazardous Locations and nonhazardous locations only. Each product is supplied with markings on the rating nameplate indicating the hazardous location temperature code. When combining products within a system, the most adverse temperature code (lowest “T” number) may be used to help determine the overall temperature code of the system. Combinations of equipment in your system are subject to investigation by the local Authority Having Jurisdiction at the time of installation.

WARNING



EXPLOSION HAZARD -

- Do not disconnect equipment unless power has been removed or the area is known to be nonhazardous.
- Do not disconnect connections to this equipment unless power has been removed or the area is known to be nonhazardous. Secure any external connections that mate to this equipment by using screws, sliding latches, threaded connectors, or other means provided with this product.
- Substitution of components may impair suitability for Class I, Division 2.
- If this product contains batteries, they must only be changed in an area known to be nonhazardous.

Informations sur l'utilisation de cet équipement en environnements dangereux:

Les produits marqués CL I, DIV 2, GP A, B, C, D ne conviennent que une utilisation en environnements de Classe I Division 2 Groupes A, B, C, D dangereux et non dangereux. Chaque produit est livré avec des marquages sur sa plaque d'identification qui indiquent le code de température pour les environnements dangereux. Lorsque plusieurs produits sont combinés dans un système, le code de température le plus défavorable (code de température le plus faible) peut être utilisé pour déterminer le code de température global du système. Les combinaisons d'équipements dans le système sont sujettes à inspection par les autorités locales qualifiées au moment de l'installation.

AVERTISSEMENT



RISQUE D'EXPLOSION -

- Couper le courant ou s'assurer que l'environnement est classé non dangereux avant de débrancher l'équipement.
- Couper le courant ou s'assurer que l'environnement est classé non dangereux avant de débrancher les connecteurs. Fixer tous les connecteurs externes reliés à cet équipement à l'aide de vis, loquets coulissants, connecteurs filetés ou autres moyens fournis avec ce produit.
- La substitution de composants peut rendre cet équipement inadapté à une utilisation en environnement de Classe 1, Division 2.
- S'assurer que l'environnement est classé non dangereux avant de changer les piles.

Specifications

Description	Value
Outputs per Module	4 Individually Isolated
Module Location	Bulletin 1771 I/O Chassis – One Slot
Output Voltage Ranges (Nominal) – 1771-OFE1	+1 to +5V DC –10 to +10V DC 0 to +10V DC
Output Current (maximum)	10mA per Channel in Voltage Mode (1771–OFE1)
Output Current Ranges (Nominal)	+4 to +20mA, 5V dc (1771–OFE2) 0 to +50mA, 12.5V dc (1771–OFE3)
Digital Resolution	12-Bit Binary – 1 Part in 4095
Output Capacitance	0.01 μ F (Voltage Outputs) 0.022 μ F (Current Outputs)
Output Impedance	<0.25 ohms for Voltage Outputs Exclusive of Contact Wiring Resistance >1.5 megohms for Current Outputs
Max Loop Impedance in the Current Mode	1771-OFE2 – Up to 1200 ohms Load Resistance 1771-OFE3 – Up to 400 ohms Load Resistance
Output Overload Protection	All outputs are protected against short circuit load conditions not to exceed one minute.
Backplane Power	1771-OFE1 – 1.50A 1771-OFE2 – 1.50A 1771-OFE3 – 2.50A
Power Dissipation	1771-OFE1 – 7.9W 1771-OFE2 – 7.9W 1771-OFE3 – 13.1W
Thermal Dissipation	1771-OFE1 – 26.9 BTU/hr 1771-OFE2 – 26.9 BTU/hr 1771-OFE3 – 44.5 BTU/hr
Adjacent Slot Power Dissipation	10 Watts (max.)
Isolation Voltage	Tested to 850V dc for 1s
D/A Converter Specifications Settling Time	0.8 ms Maximum for a Resistive Load
Internal Scan Rate	8.0 ms for All Channels Using BCD Data and Scaling 1.6 ms for All Channels Using Binary Data and No Scaling
Accuracy (Including Linearity, Gain, and Offset at 25°C)	+0.1% of Full Scale +1/2 LSD (BCD Mode) +1/2 LSB (BINARY Mode)
Temperature Coefficient	+50 ppm/°C of Full Scale Range

Description	Value
Environmental Conditions	
Operating Temperature	IEC 60068-2-1 (Test Ad, Operating Cold) IEC 60068-2-2 (Test Bd, Operating Dry Heat) IEC 60068-2-14 (Test Nb, Operating Thermal Shock) 32 to 140°F (0 to 60°C)
Storage Temperature	IEC 60068-2-1 (Test Ab, Unpackaged, Nonoperating Cold) IEC 60068-2-2 (Test Bb, Unpackaged, Nonoperating Dry Heat) IEC 60068-2-14 (Test Na, Unpackaged, Nonoperating Thermal Shock) -40 to 185°F (-40 to 85°C)
Relative Humidity	IEC 60068-2-30 (Test Db, Unpackaged, Nonoperating Damp Heat) 5 to 95%, noncondensing
Shock	IEC 60068-2-27 (Test Ea, Unpackaged Shock)
Operating	30g
Nonoperating	50g
Vibration	IEC 60068-2-6 (Test Fc, Operating) 2g @ 10-500Hz
ESD Immunity	IEC 61000-4-2 4kV contact discharges
Radiated RF Immunity	IEC 61000-4-3 10V/m with 1kHz sine-wave 80% AM from 30MHz to 1000MHz 10V/m with 200Hz 50% Pulse 100%AM at 900MHz
EFT/B Immunity	IEC 61000-4-4 ±1kV @ 5kHz on signal ports
Surge Transient Immunity	IEC 61000-4-5 ±2kV line-earth (CM) on shielded ports
Conducted RF Immunity	IEC 61000-4-6 10V rms with 1kHz sine wave 80% AM from 150kHz to 30MHz
Emissions	CISPR 11 Group 1, Class A (with appropriate enclosure)
Specifications continued on next page.	

Description	Value
Enclosure Type Rating	None (open-style)
Keying	Between 10 and 12 Between 26 and 28
Field Wiring Arm	Catalog No. 1771-WC
Field Wiring Arm Screw Torque	7-9 pound-inches (0.6-0.7Nm)
Conductors Wire Size	12 gauge (4mm ²) maximum stranded copper wire, (Belden 8761)
Category	3/64 inch (1.2mm) insulation maximum 2 ¹
Certifications (when product is marked)	<p>UL UL Listed Industrial Control Equipment</p> <p>CSA CSA Certified Process Control Equipment for Class I, Division 2 Group A, B, C, D Hazardous Locations</p> <p>CSA CSA Certified Process Control Equipment</p> <p>CE² European Union 89/336/EEC EMC Directive, compliant with: EN 61000-6-4, Industrial Emissions EN 50082-2, Industrial Immunity EN 61326, Meas./Control/Lab., Industrial Requirements EN 61000-6-2, Industrial Immunity</p> <p>EEEx² European Union 94/9/EEC ATEX Directive, compliant with: EN 50021, Potentially Explosive Atmospheres, Protection "n"</p> <p>C-Tick² Australian Radiocommunications Act, compliant with AS/NZS 2064, Industrial Emissions</p>
User Manual	Publication 1771-UM030
<p>¹ Use this conductor category information for planning conductor routing. Refer to publication 1770-4.1, "Industrial Automation Wiring and Grounding Guidelines."</p> <p>² See the Product Certification link at www.ab.com for Declarations of Conformity, Certificates and other certification details</p>	

European Zone 2 Certification

This equipment is intended for use in potentially explosive atmospheres as defined by European Union Directive 94/9/EC.

The LCIE (Laboratoire Central des Industries Electriques) certifies that this equipment has been found to comply with the Essential Health and Safety Requirements relating to the design and construction of Category 3 equipment intended for use in potentially explosive atmospheres, given in Annex II to this Directive. The examination and test results are recorded in confidential report No. 28 682 010.

Compliance with the Essential Health and Safety Requirements has been assured by compliance with EN 50021 (1999).

IMPORTANT

Observe the following additional Zone 2 certification requirements:

- This equipment is not resistant to sunlight or other sources of UV radiation.
 - The secondary of a current transformer shall not be open-circuited when applied in Class I, Zone 2 environments.
 - Equipment of lesser Enclosure Type Rating must be installed in an enclosure providing at least IP54 protection when applied in Class I, Zone 2 environments.
 - This equipment shall be used within its specified ratings defined by Allen-Bradley.
 - Provision shall be made to prevent the rated voltage from being exceeded by transient disturbances of more than 40% when applied in Class I, Zone 2 environments.
-

勝特力材料 886-3-5753170
勝特力电子(上海) 86-21-34970699
勝特力电子(深圳) 86-755-83298787
[Http://www.100y.com.tw](http://www.100y.com.tw)