



Analog Input Module (Catalog Number 1771-IFE/C)

Contents



This icon is used when additional information is available in the *Analog Input Module User Manual*, publication 1771-6.5.115.

If you need a copy of this manual, fax the enclosed User Manual Request Card to 1-800-576-6340. If you are outside the U.S., fax the card to 1-330-723-4036.

勝特力材料 886-3-5753170
勝特力电子(上海) 86-21-34970699
勝特力电子(深圳) 86-755-83298787
[Http://www.100y.com.tw](http://www.100y.com.tw)

Use this document as a guide when installing the 1771-IFE/C analog input module.

| To | See page |
|--|----------|
| ↓ Prevent Electrostatic Discharge | Below |
| ↓ Understand Compliance to European Union Directives | 2 |
| ↓ Understand Product Compatibility | 2 |
| ↓ Calculate Power Requirements | 3 |
| ↓ Determine Module Placement | 3 |
| ↓ Set the A/B Simulation Jumper | 3 |
| ↓ Set the Configuration Jumpers | 4 |
| ↓ Key the Backplane Connector | 4 |
| ↓ Install the Module and Field Wiring Arm | 5 |
| ↓ Connect Wiring to the Field Wiring Arm | 6 |
| ↓ Ground the Chassis and Module | 9 |
| ↓ Configure the Module | 10 |

| For this reference information | See page |
|---|----------|
| ➡ Status Indicators | 12 |
| ➡ Troubleshooting | 13 |
| ➡ Specifications | 13 |
| ➡ CSA Hazardous Approval | 15 |
| ➡ Differences Between Series A, B and C Modules | 16 |

Prevent Electrostatic Discharge

The analog input module is sensitive to electrostatic discharge.



ATTENTION: Electrostatic discharge can damage integrated circuits or semiconductors if you touch backplane connector pins. Follow these guidelines when you handle the module:

- Touch a grounded object to discharge static potential
- Wear an approved wrist-strap grounding device
- Do not touch the backplane connector or connector pins
- Do not touch circuit components inside the module
- If available, use a static-safe work station
- When not in use, keep the module in its static-shield box

Understand Compliance to European Union Directives

If this product has the CE mark it is approved for installation within the European Union and EEA regions. It has been designed and tested to meet the following directives.

EMC Directive

This product is tested to meet Council Directive 89/336/EEC Electromagnetic Compatibility (EMC) and the following standards, in whole or in part, documented in a technical construction file:

- EN 50081-2EMC – Generic Emission Standard, Part 2 – Industrial Environment
- EN 50082-2EMC – Generic Immunity Standard, Part 2 – Industrial Environment

This product is intended for use in an industrial environment.

Low Voltage Directive

This product is tested to meet Council Directive 73/23/EEC Low Voltage, by applying the safety requirements of EN 61131–2 Programmable Controllers, Part 2 – Equipment Requirements and Tests.

For specific information required by EN 61131-2, see the appropriate sections in this publication, as well as these Allen-Bradley publications:

| Publication | Publication number |
|---|--------------------|
| <i>Industrial Automation Wiring and Grounding Guidelines For Noise Immunity</i> | 1770-4.1 |
| <i>Guidelines for Handling Lithium Batteries</i> | AG-5.4 |
| <i>Automation Systems Catalog</i> | B111 |

Understand Product Compatibility

The 1771-IFE module can be used with any 1771 I/O chassis. Compatibility and data table use is listed below.

| Catalog Number | Use of Data Table | | | | Compatibility | | | |
|----------------|-------------------|-------------------|------------------|-------------------|---------------|--------|--------|----------------|
| | Input Image Bits | Output Image Bits | Read Block Words | Write Block Words | Addressing | | | Chassis Series |
| | | | | | 1/2-Slot | 1-Slot | 2-Slot | |
| 1771-IFE | 8 | 8 | 22 | 39 | Y | Y | Y | A, B |

A = Compatible with 1771-A1, -A2, -A4
 B = Compatible with 1771-A1B, -A2B, -A3B, -A3B1, -A4B
 Y = Compatible without restriction.

Do not use this module with cat. no. 1771-AL PLC-2/20 or 2/30 Local Adapter.

Calculate Power Requirements

The module receives its power through the 1771 I/O power supply and requires 500mA from the backplane.

Add this current to the requirements of all other modules in the I/O chassis to prevent overloading the chassis backplane and/or backplane power supply.

Determine Module Placement in the I/O Chassis

Place your module in any I/O module slot of the I/O chassis except for the extreme left slot. This slot is reserved for PC processors or adapter modules.



ATTENTION: Do not insert or remove modules from the I/O chassis while system power is ON. Failure to observe this rule could result in damage to module circuitry.

Group your modules to minimize adverse affects from radiated electrical noise and heat. We recommend the following.

- Group analog input and low voltage dc modules away from ac modules or high voltage dc modules to minimize electrical noise interference.
- Do not place this module in the same I/O group with a discrete high-density I/O module when using 2-slot addressing. This module uses a byte in both the input and output image tables for block transfer.

Set the A/B Simulation Jumper

The module is shipped with the A/B simulation jumper set in position **POS G** for Series C applications. This setting returns input data above and below the range end points. If you are replacing a Series A or B 1771-IFE module with this module, reset the simulation jumper to the **POS E** position as shown below.

Set the Series A/B Simulation Jumper

1. Locate the simulation jumper at the top edge of the module circuit board.
2. Using your fingers, slide the jumper off the 2 posts.
3. Carefully position the jumper on 2 of the 3 posts that correspond to your requirement.

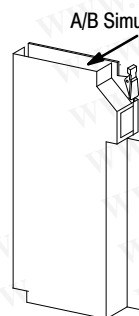

A/B Simulation Jumper

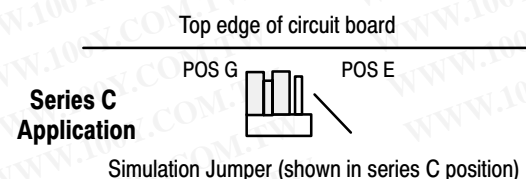
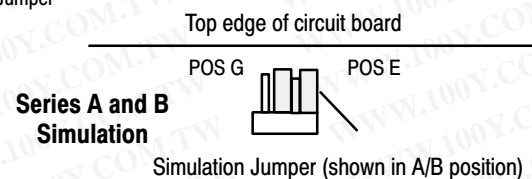

Set the Configuration Jumpers and Key the Backplane Connector

The module has configuration jumpers for determining the input type (voltage or current) desired for each input. **The module is shipped with the configuration jumpers positioned for voltage mode and the A/B simulation jumper set for Series C. If you are replacing a Series A or B 1771-IFE module with this module, reset the simulation jumper as shown above.**

You can select either voltage or current for each input, but all inputs must be either single-ended or differential. **Do not mix single-ended and differential inputs on the module.**

1 Remove the four screws securing the side cover to the module and remove the covers.

19805

3 Reposition the cover and secure with the four screws removed in step 1.

19813

2 Reposition the configuration jumpers associated with each input channel according to your requirements

You can mix voltage mode and current mode settings on the module. Make sure that the entire module is set for either single-ended or differential. Do not mix them.

Voltage Mode
Differential or Single-ended (factory set)

Current Mode

Differential Current:

Single-ended Current:

Single-ended

Odd channel current:

Even channel voltage:

Even channel current:

Odd channel voltage:

Configuration Jumpers

| Single-ended | Differential |
|-------------------|--------------|
| Channel 1 and 2 | Channel 1 |
| Channel 3 and 4 | Channel 2 |
| Channel 5 and 6 | Channel 3 |
| Channel 7 and 8 | Channel 4 |
| Channel 9 and 10 | Channel 5 |
| Channel 11 and 12 | Channel 6 |
| Channel 13 and 14 | Channel 7 |
| Channel 15 and 16 | Channel 8 |

4 **Key the Backplane Connector**

Place your module in any slot in the chassis except the leftmost slot which is reserved for processors or adapters.

Position the keying bands in the backplane connectors to correspond to the key slots on the module.

Place the keying bands:
 between 10 and 12
 between 24 and 26

You can change the position of these bands if subsequent system design and rewiring makes insertion of a different type of module necessary.

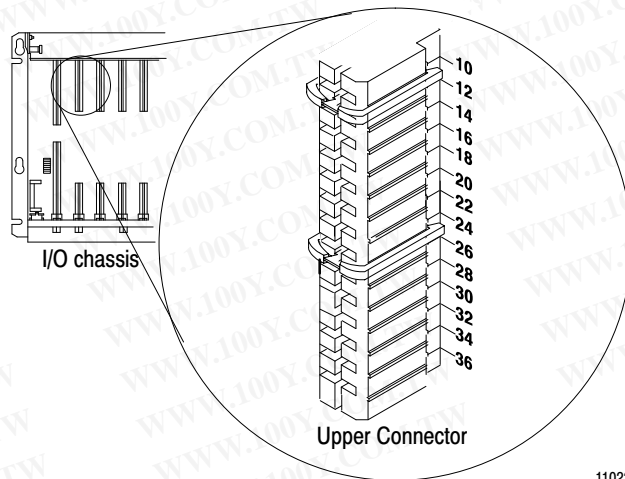

11022-1

Install the Module and Field Wiring Arm



ATTENTION: Remove power from the 1771 I/O chassis backplane and field wiring arm before removing or installing an I/O module.

- Failure to remove power from the backplane or wiring arm could cause module damage, degradation of performance, or injury.
- Failure to remove power from the backplane could cause injury or equipment damage due to possible unexpected operation.

1

Place the module in the card guides on the top and bottom of the chassis that guide the module into position.

Important: Apply firm even pressure on the module to seat it into its backplane connector.

1771-A1B, -A2B, -A3B, -A3B1, -A4B I/O chassis

1771-A1B, -A2B, -A3B1, -A4B Series B I/O chassis

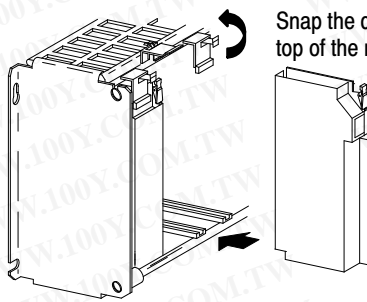

Snap the chassis latch over the top of the module to secure it.

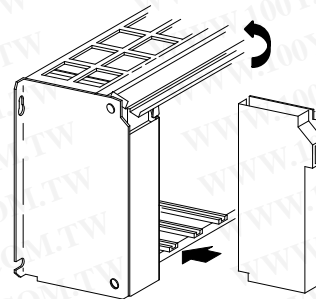

Swing the chassis locking bar down into place to secure the modules. Make sure the locking pins engage.

2

Attach the wiring arm (1771-WG) to the horizontal bar at the bottom of the I/O chassis.

The wiring arm pivots upward and connects with the module so you can install or remove the module without disconnecting the wires.

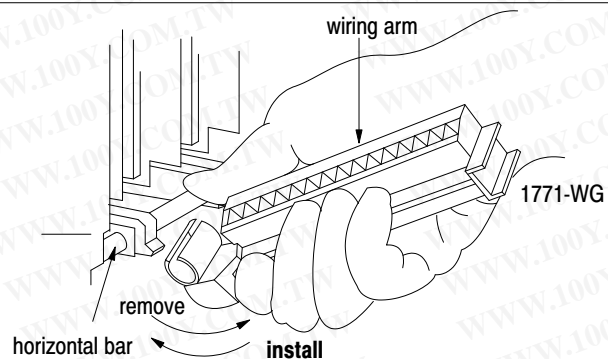

17643

Connect Wiring to the Field Wiring Arm

Connect your I/O devices to the cat. no. 1771-WG wiring arm shipped with the module.



ATTENTION: Remove power from the 1771 I/O chassis backplane and field wiring arm before removing or installing an I/O module.

- Failure to remove power from the backplane or wiring arm could cause module damage, degradation of performance, or injury.
- Failure to remove power from the backplane could cause injury or equipment damage due to possible unexpected operation.

Input connections for the 1771-IFE module with:

- single-ended inputs are shown on page 7
- differential inputs are shown on page 8

Minimizing Ground Loops

To minimize ground-loop currents on input circuits:

- use single-ended mode whenever possible
- use 2-wire transmitters with a common power supply
- separate 2-wire and 4-wire transmitters between different modules
- tie 4-wire transmitter and/or separate power supply grounds together

Important: We do not recommend mixing 2-wire and 4-wire transmitter inputs on the same module. Power supply placement can make it impossible to eliminate ground loops.

Cable Lengths

Recommended maximum cable length for voltage-mode input devices is 50 feet. This recommendation is based on considerations of signal degradation and electrical noise immunity in typical industrial environments. Cable length for current-mode input devices need not be as restrictive because analog signals from these devices are less sensitive to electrical noise interference.

Connection Diagram for 16 Single-ended Inputs and Two-Wire Transmitters

Note: Refer to transmitter manufacturers specifications for power supply connections.

NOTE:

- All module commons are electrical-ly tied together inside the module.
- Jumper all unused channels to module common to reduce noise.
- Tie power supply grounds together to minimize ground loops.

Attention: Analog input signals must be within $\pm 14.25V$ referenced to module common. This input signal includes any common mode voltage present between either input terminal and module common. If an input terminal exceeds this range, channel-to-channel crosstalk can cause invalid input readings and invalid underrange or overrange bits.

The 1771-IFE module does not supply loop power for the input device. The user must supply loop power for loop-powered input devices.

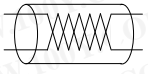

The sensor cable must be shielded. The shield must:

- extend the length of the cable, but be connected only at the 1771 I/O chassis
- extend up to the point of termination

Important: The shield should extend to the termination point, exposing just enough cable to adequately terminate the inner conductors. Use heat shrink or another suitable insulation where the wire exits the cable jacket.

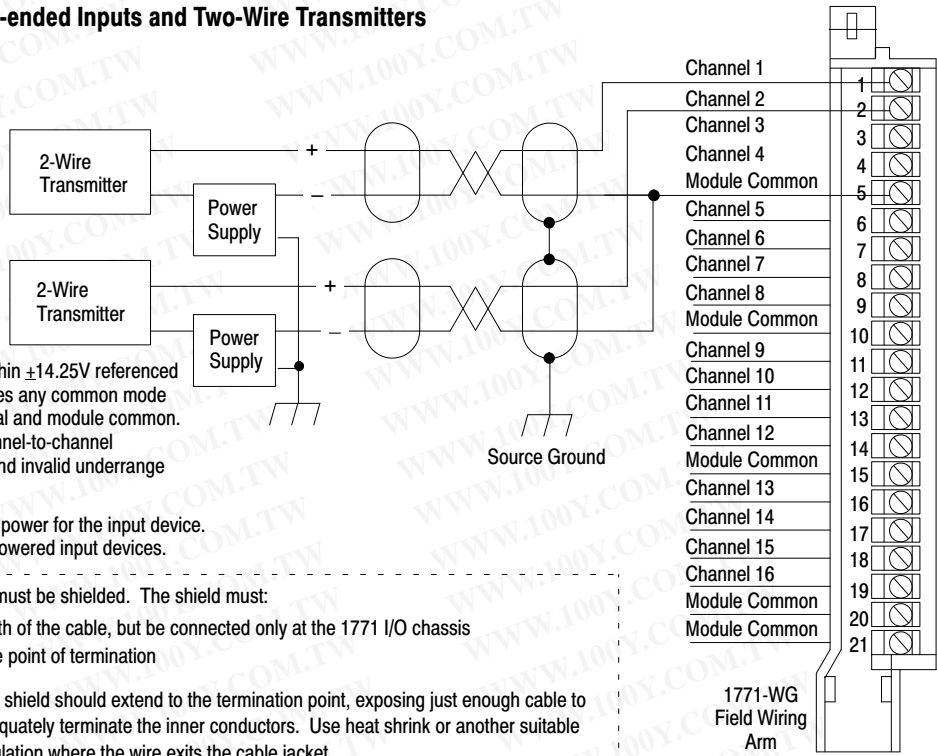

Connection Diagram for 16 Single-ended Inputs and Four-Wire Transmitters

Note: Refer to transmitter manufacturers specifications for power supply connections.

NOTE:

- All module commons are electrical-ly tied together inside the module.
- Jumper all unused channels to module common to reduce noise.
- Tie power supply grounds together to minimize ground loops.

Attention: Analog input signals must be within $\pm 14.25V$ referenced to module common. This input signal includes any common mode voltage present between either input terminal and module common. If an input terminal exceeds this range, channel-to-channel crosstalk can cause invalid input readings and invalid underrange or overrange bits.

The 1771-IFE module does not supply loop power for the input device. The user must supply loop power for loop-powered input devices.

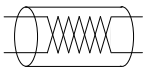

The sensor cable must be shielded. The shield must:

- extend the length of the cable, but be connected only at the 1771 I/O chassis
- extend up to the point of termination

Important: The shield should extend to the termination point, exposing just enough cable to adequately terminate the inner conductors. Use heat shrink or another suitable insulation where the wire exits the cable jacket.

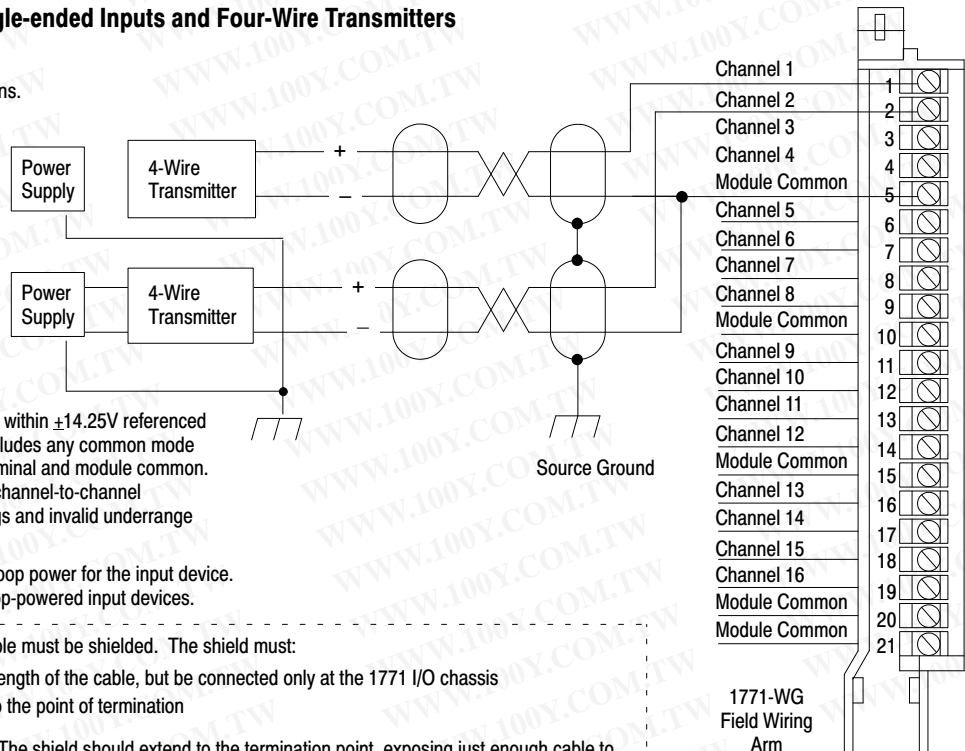

Connection Diagram for 8 Differential Inputs and Two-Wire Transmitters

Note: Refer to transmitter manufacturers specifications for power supply connections.

NOTE:

- Unused channels must have their + and - inputs jumpered together and tied to module common to reduce noise.
- Tie power supply grounds together to minimize ground loops.

Attention: Analog input signals must be within $\pm 14.25V$ referenced to module common. If an input channel exceeds this range, channel-to-channel crosstalk can cause invalid input readings and invalid underrange or overrange bits.

The 1771-IFE module does not supply loop power for the input device. The user must supply loop power for loop-powered input devices.

Configuring the module for differential inputs does not provide isolation.

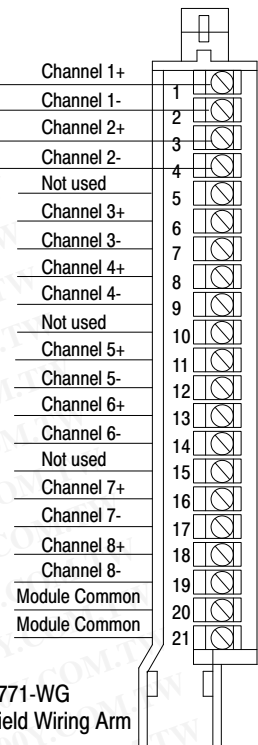
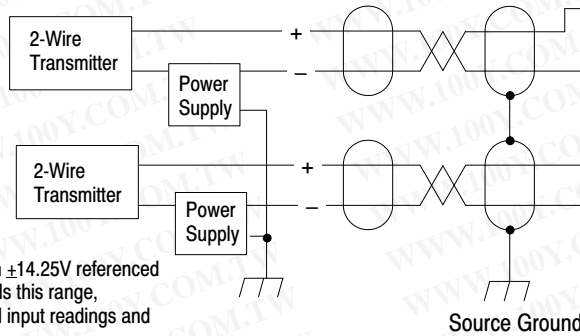

- The sensor cable must be shielded. The shield must:
- extend the length of the cable, but be connected only at the 1771 I/O chassis
 - extend up to the point of termination

Important: The shield should extend to the termination point, exposing just enough cable to adequately terminate the inner conductors. Use heat shrink or another suitable insulation where the wire exits the cable jacket.

1771-WG Field Wiring Arm

Connection Diagram for 8 Differential Inputs and Four-Wire Transmitters

Note: Refer to transmitter manufacturers specifications for power supply connections.

NOTE:

- Unused channels must have their + and - inputs jumpered together and tied to module common to reduce noise.
- Tie power supply grounds together to minimize ground loops.

Attention: Analog input signals must be within $\pm 14.25V$ referenced to module common. If an input channel exceeds this range, channel-to-channel crosstalk can cause invalid input readings and invalid underrange or overrange bits.

The 1771-IFE module does not supply loop power for the input device. The user must supply loop power for loop-powered input devices.

Configuring the module for differential inputs does not provide isolation.

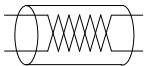
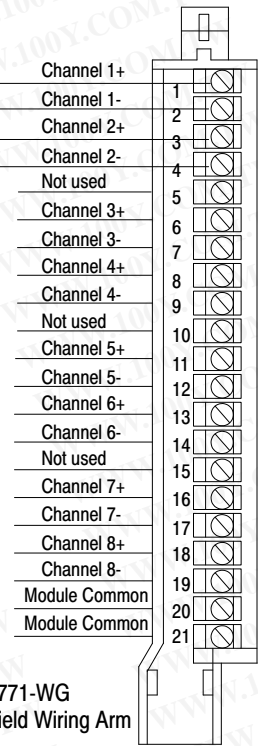
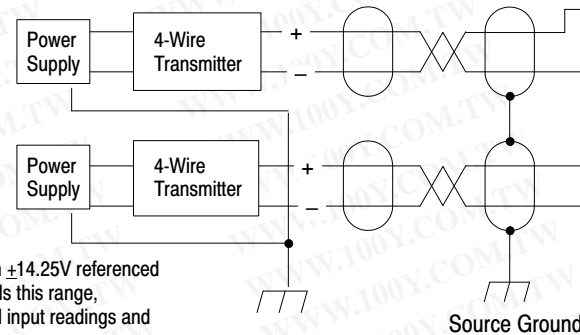

- The sensor cable must be shielded. The shield must:
- extend the length of the cable, but be connected only at the 1771 I/O chassis
 - extend up to the point of termination

Important: The shield should extend to the termination point, exposing just enough cable to adequately terminate the inner conductors. Use heat shrink or another suitable insulation where the wire exits the cable jacket.

1771-WG Field Wiring Arm

Ground the Chassis and Module

Use the following diagrams to ground your I/O chassis and analog input module. Follow these steps to prepare the cable:

- 1 Remove a length of cable jacket from the Belden 8761 cable.



- 2 Pull the foil shield and bare drain wire from the insulated wires.

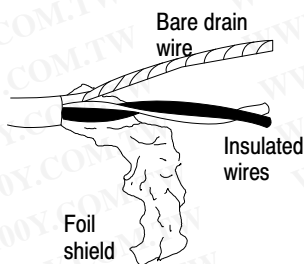

- 3 Twist the foil shield and drain wire together to form a single strand.



- 4 Attach a ground lug.



- 5 Fold shield back, and apply shrink tubing to secure.



When using shielded cable wire, ground the foil shield and drain wire only at one end of the cable. We recommend that you wrap the foil shield and drain wire together and connect them to a chassis mounting bolt. At the opposite end of the cable, tape exposed shield and drain wire with electrical tape to insulate it from electrical contact.

Refer to Industrial Automation Wiring and Grounding Guidelines for Noise Immunity, publication 1770-4.1, for additional information.

Chassis Ground

When you connect grounding conductors to the I/O chassis grounding stud, place a star washer under the first lug, then place a nut with captive lock washer on top of each ground lug.

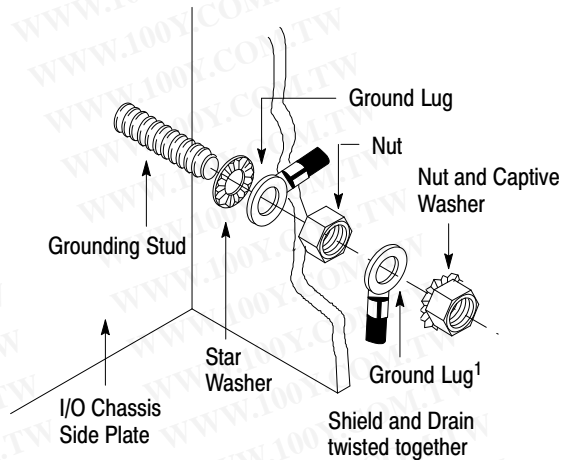

¹Use the cup washer if crimp-on lugs are not used.

Single-point Grounding

Extend shield to termination point. Expose just enough cable to adequately terminate inner conductors.

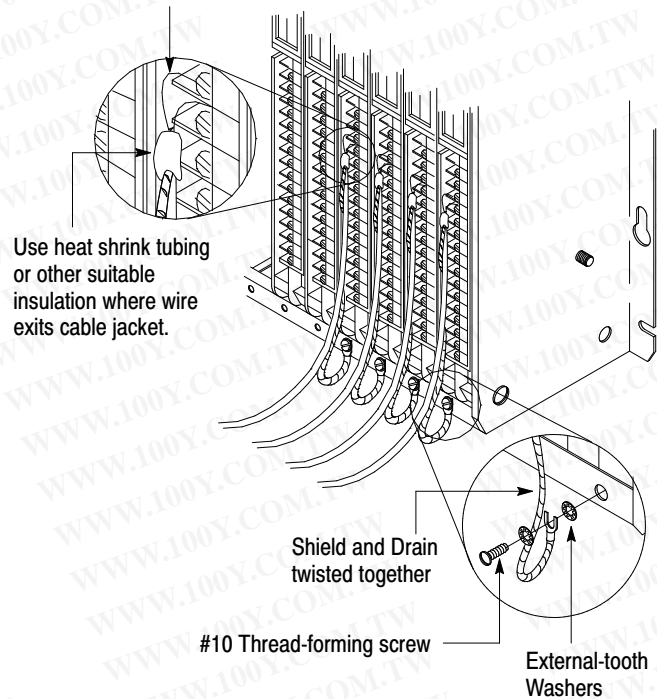

Configure the Module



For detailed configuration information, see chapter 2 of your *Analog Input User Manual* (publication 1771-6.5.115).

Because of the many analog devices available and the wide variety of possible applications, you must configure the module to conform to the analog device and specific application that you have chosen. Use the configuration information below to configure your module to your specifications.

| Dec. Bits | 15 | 14 | 13 | 12 | 11 | 10 | 09 | 08 | 07 | 06 | 05 | 04 | 03 | 02 | 01 | 00 | Description | | | | | | | | | | | | | | | |
|---|--|-------------------------|--------|-----------------------------|---------------------------------|------------|----------------|----|----|----|--|----|----|----|----|-----------------------------------|-----------------------------------|-------------|-------------|-------------|---|---|---------------|---|---|----------|---|---|-------------------------|---|---|-------------------------|
| Octal Bits | 17 | 16 | 15 | 14 | 13 | 12 | 11 | 10 | 07 | 06 | 05 | 04 | 03 | 02 | 01 | 00 | | | | | | | | | | | | | | | | |
| Word 1 | 8 | | 7 | | 6 | | 5 | | 4 | | 3 | | 2 | | 1 | | Range Selection - Channels 1 - 8 | | | | | | | | | | | | | | | |
| 2 | 16 | | 15 | | 14 | | 13 | | 12 | | 11 | | 10 | | 9 | | Range Selection - Channels 9 - 16 | | | | | | | | | | | | | | | |
| Input range selections allow the user to configure the inputs for any of 7 input voltage or current ranges. Two bits are required for each channel. Bits 00 and 01 for channel 1, bits 02 and 03 for channel 2, etc. | Bit 01 | | Bit 00 | | Voltage or Current Input | | | | | | | | | | | | | | | | | | | | | | | | | | | |
| | 0 | | 0 | | 1 to 5V dc, 4 to 20mA (default) | | | | | | | | | | | | | | | | | | | | | | | | | | | |
| | 0 | | 1 | | 0 to 5V dc, 0 to 20mA | | | | | | | | | | | | | | | | | | | | | | | | | | | |
| | 1 | | 0 | | -5 to +5V dc, -20 to +20mA | | | | | | | | | | | | | | | | | | | | | | | | | | | |
| 1 | | 1 | | -10 to +10V dc, 0 to 10V dc | | | | | | | | | | | | | | | | | | | | | | | | | | | | |
| 3 | Real Time Sampling | | | | Data Format | Input Type | Digital Filter | | | | Real time sampling, data format, input type and digital filter | | | | | | | | | | | | | | | | | | | | | |
| <p>Real time sampling - Default is no RTS.</p> <p>Data format - set to match your processor.</p> <table border="1"> <tr> <td>Bit 10 (12)</td> <td>Bit 09 (11)</td> <td>Data format</td> </tr> <tr> <td>0</td> <td>0</td> <td>BCD (default)</td> </tr> <tr> <td>0</td> <td>1</td> <td>Reserved</td> </tr> <tr> <td>1</td> <td>0</td> <td>Two's complement binary</td> </tr> <tr> <td>1</td> <td>1</td> <td>Signed magnitude binary</td> </tr> </table> <p>Digital filter reduces effect of noise on input. (Default is no filter.)</p> <p>Input type, set bit for differential mode on all channels. Reset (0) = single-ended inputs (default) Set (1) = differential inputs</p> | | | | | | | | | | | | | | | | | | Bit 10 (12) | Bit 09 (11) | Data format | 0 | 0 | BCD (default) | 0 | 1 | Reserved | 1 | 0 | Two's complement binary | 1 | 1 | Signed magnitude binary |
| Bit 10 (12) | Bit 09 (11) | Data format | | | | | | | | | | | | | | | | | | | | | | | | | | | | | | |
| 0 | 0 | BCD (default) | | | | | | | | | | | | | | | | | | | | | | | | | | | | | | |
| 0 | 1 | Reserved | | | | | | | | | | | | | | | | | | | | | | | | | | | | | | |
| 1 | 0 | Two's complement binary | | | | | | | | | | | | | | | | | | | | | | | | | | | | | | |
| 1 | 1 | Signed magnitude binary | | | | | | | | | | | | | | | | | | | | | | | | | | | | | | |
| 4 | Minimum sign bits , when set, designate negative minimum scaling values for the corresponding input channels. Bit 00 corresponds to channel 1, bit 01 corresponds to channel 2, etc. | | | | | | | | | | | | | | | Sign Bits, minimum scaling values | | | | | | | | | | | | | | | | |
| 5 | Maximum sign bits , when set, designate maximum scaling values that are negative. Maximum scaling value must be greater than minimum on any particular channel. Bit 00 corresponds to channel 1, bit 01 corresponds to channel 2, etc. | | | | | | | | | | | | | | | Sign Bits, maximum scaling values | | | | | | | | | | | | | | | | |
| 6, 8, 10, 12, 14, 16, 18, 20, 22, 24, 26, 28, 30, 32, 34, 36 | Minimum scaling values for each channel. Enter in BCD format. | | | | | | | | | | | | | | | Channel 1 - minimum scaling | | | | | | | | | | | | | | | | |
| 7, 9, 11, 13, 15, 17, 19, 21, 23, 25, 27, 29, 31, 33, 35, 37 | Maximum scaling values for each channel. Enter in BCD format. | | | | | | | | | | | | | | | Channel 1 - maximum scaling | | | | | | | | | | | | | | | | |
| 38 | Offset calibration - Each bit represents a channel (bit 00 to channel 1, bit 01 to channel 2, etc.). When the bit is set, and a BTW has been sent, the module will read the channels and adjust the offset to analog ground potential. In differential mode, bits 08 thru 15 (10 thru 17 in octal) are ignored. In current mode, apply 0mA. | | | | | | | | | | | | | | | Offset Calibration | | | | | | | | | | | | | | | | |
| 39 | Gain calibration - Each bit represents a channel (bit 00 to channel 1, bit 01 to channel 2, etc.). When the bit is set, and a BTW has been sent, the module will read the channels and adjust the gain correction values. If used on +, 0 to 5, or 1 to 5V ranges, a value of 5V is expected. If used on +10V range, 10V is expected. In differential mode, bits 08 thru 15 (10 thru 17 in octal) are ignored. In current mode, apply 20mA. | | | | | | | | | | | | | | | Gain Calibration | | | | | | | | | | | | | | | | |

Use the following table to read data from your input module.

| Dec. Bits | 15 | 14 | 13 | 12 | 11 | 10 | 09 | 08 | 07 | 06 | 05 | 04 | 03 | 02 | 01 | 00 | Description |
|------------|----|----|----|----|----|----|----|----|----|----|----|----|-----|----|----|----|-------------|
| Octal Bits | 17 | 16 | 15 | 14 | 13 | 12 | 11 | 10 | 07 | 06 | 05 | 04 | 03 | 02 | 01 | 00 | |
| Word 1 | | | | | | | | | | HF | EE | CS | RTS | IS | OR | PU | Diagnostics |

Hardware fault - (HF) When this bit is set, the dc/dc converter fuse has blown. Digital logic will continue to operate.

EEPROM status bit - (EE) This bit is set if an error occurs saving calibration data to nonvolatile memory. If this bit is set at powerup, the data from the EEPROM did not pass the checksum and no calibration values are used.

Calibration status bit - (CS) When calibrating the module, this bit will be cleared if the calibration was successful. If the bit is set, an incorrect voltage/current was applied, or offset and gain calibrations were attempted simultaneously.

Real time sample fault bit - (RTS) This bit is set if the module is configured for RTS and a block transfer read has not occurred within the user-programmed period.

Power up bit - (PU) Used by the module to tell the processor that it is alive but not yet configured. It is a key element in the application program.

Out of range bit - (OR) This bit is sent to tell the processor that one or more channels are either over or under range.¹

Invalid scaling bit - (IS) This bit reports that the scaling is somehow invalid. Usually, both values are equal or minimum is greater than maximum when this bit comes on. Can also be an **invalid filter** value.

| Octal Bits | 17 | 16 | 15 | 14 | 13 | 12 | 11 | 10 | 07 | 06 | 05 | 04 | 03 | 02 | 01 | 00 | Description |
|------------|--|----|----|----|----|----|----|----|----|----|----|----|----|----|----|---------------------------------|-----------------------------------|
| 2 | 16 | 15 | 14 | 13 | 12 | 11 | 10 | 9 | 8 | 7 | 6 | 5 | 4 | 3 | 2 | 1 | Data underrange for channels 1–16 |
| 3 | 16 | 15 | 14 | 13 | 12 | 11 | 10 | 9 | 8 | 7 | 6 | 5 | 4 | 3 | 2 | 1 | Data overrange for channels 1–16 |
| | <p>Underrange bits for each channel. Bit 00 for channel 1, bit 01 for channel 2, etc.¹ These bits are set (1) at approximately the input range limits shown on the right.</p> <p>Overrange bits for each channel. Bit 00 for channel 1, bit 01 for channel 2, etc.¹ These bits are set (1) at approximately the input range limits shown on the right.</p> | | | | | | | | | | | | | | | 1 to 5V dc, 4 to 20mA (default) | |
| | | | | | | | | | | | | | | | | 0 to 5V dc, 0 to 20mA | |
| | | | | | | | | | | | | | | | | -5 to +5V dc, -20 to +20mA | |
| | | | | | | | | | | | | | | | | -10 to +10V dc, 0 to 10V dc | |
| 4 | 16 | 15 | 14 | 13 | 12 | 11 | 10 | 9 | 8 | 7 | 6 | 5 | 4 | 3 | 2 | 1 | Data polarity for channels 1–16 |
| | <p>Polarity bits – Set when input is less than zero. Bit 00 for channel 1, bit 01 for channel 2, etc.</p> | | | | | | | | | | | | | | | | |
| 5 | Channel 1 Input | | | | | | | | | | | | | | | Channel 1 Input | |
| 6 | Channel 2 Input | | | | | | | | | | | | | | | Channel 2 Input | |
| 7 | Channel 3 Input | | | | | | | | | | | | | | | Channel 3 Input | |
| 8 | Channel 4 Input | | | | | | | | | | | | | | | Channel 4 Input | |
| | | | | | | | | | | | | | | | | | |
| 20 | Channel 16 Input | | | | | | | | | | | | | | | Channel 16 Input | |
| 21 | <p>Offset calibration results bits – Each bit represents a channel. After a calibration BTW has been sent, the module confirms calibration by echoing back the channels that were calibrated during the offset calibration BTW. In differential mode, channels 09 thru 16 are zero.</p> | | | | | | | | | | | | | | | Offset Calibration Results | |
| 22 | <p>Gain calibration results bits – Each bit represents a channel. After a calibration BTW has been sent, the module confirms calibration by echoing back the channels that were calibrated during the gain calibration BTW. In differential mode, channels 09 thru 16 are zero.</p> | | | | | | | | | | | | | | | Gain Calibration Results | |

¹ **Attention:** If an input terminal's voltage exceeds $\pm 14.25V$ as referenced to module common, channel-to-channel crosstalk can cause invalid input readings and invalid underrange/overrange bits.

Default Configuration

If a write block of five words with all zeroes is sent to the module, default selections will be:

- 1 to 5V dc or 4 to 20mA (dependent on configuration jumper setting)
- BCD data format
- no real time sampling (RTS)
- no filtering
- no scaling
- single-ended inputs

Interpret Status Indicators

The front panel of the analog input module contains a green RUN indicator and a red FAULT indicator. At power-up, the module momentarily turns on the red indicator as a lamp test, then checks for:

- correct RAM operation
- firmware errors

If there is no fault, the red indicator turns off.

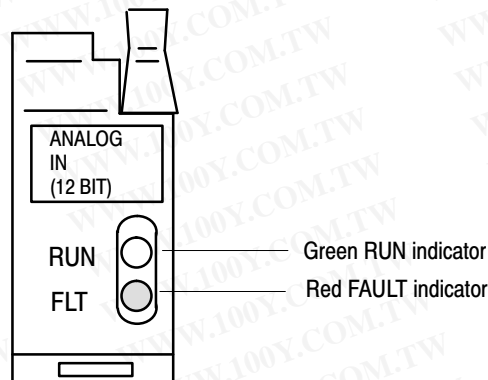

The green indicator comes on when the module is powered. It will flash until the module is programmed. If a fault is found initially or occurs later, the red fault indicator lights. The module also reports status and specific faults (if they occur) in every transfer of data (BTR) to the PC processor. Monitor the green and red indicators and status bits in word 1 of the BTR file when troubleshooting your module.

Troubleshooting

Possible module fault causes and corrective action is described in the following table.





For detailed troubleshooting information, see chapter 7 of your *Analog Input User Manual* (publication 1771-6.5.115).

| Indicators | Probable Cause | Recommended Action |
|---------------------------------------|--|---|
| RUN (green on) FLT (red off) | Normal operation | None |
| RUN (green blinking) FLT (red off) | Awaiting configuration Block Transfer Write | Send configuration BTW |
| RUN (green off) FLT (red on) | Hardware failure in module | Return module for repair |
| RUN (green off) FLT (red off) | No power | Turn off power. Remove and reinsert module into chassis. Return power. If problem still exists, and chassis power supply is functioning properly, return the module for repair. |

Specifications

| Description | Value |
|---|---|
| Inputs per module | 16 single-ended; 8 differential low level |
| Module Location | 1771 I/O rack – 1 slot |
| Input voltage ranges (nominal) | +1 to +5V dc 0 to +5V dc -5 to +5V dc -10 to +10V dc 0 to +10V dc |
| Input current ranges (nominal) | +4 to +20mA 0 to +20mA -20 to +20mA |
| Resolution | 12-bit binary 12 bits plus sign on bipolar ranges |
| Accuracy | 0.1% of full scale range @ 25°C |
| Linearity | ±1 LSB |
| Repeatability | ±1 LSB |
| Isolation Voltage | Isolation meets or exceeds UL Standard 508, and CSA Standard C22.2 No. 142. |
| Input overvoltage protection | 200V (voltage mode) ¹ 8V (current mode) ² |
| Input overcurrent protection (current ranges) | 30mA |
| Common mode voltage | ±14.25 Volts |
| Input impedance | >10 Megohms for voltage ranges; 250 ohms for current ranges |
| Common mode rejection | 80 db, dc–120 Hz |
| Current Requirements | 500mA @ +5V from I/O chassis backplane |
| Power Dissipation | 2.5 Watts (maximum) |

Specifications continued on next page





| Description | Value |
|---|--|
| Thermal Dissipation | 8.52 BTU/hr (maximum) |
| Unscaled BCD and binary output to processor | 0000 to +4095 ₁₀ for polar ranges (0 to 5V, +1 to +5V, 0 to +20mA, and +4 to +20mA) -4095 ₁₀ to 4095 ₁₀ for bipolar ranges ($\pm 5V$, $\pm 10V$, $\pm 20mA$) |
| Engineering units sent to processor | $\pm 9999_{10}$ with selectable scaling |
| Internal scan rate | 13.7 ms for 8 differential inputs (no digital filtering) –add 0.3ms for filtering 27.4 ms for 16 single-ended input (no digital filtering) –add 0.3 for filtering |
| Environmental conditions | |
| Operational temperature: | 0 to 60°C (32 to 140°F) |
| Storage temperature: | -40 to 85°C (-40 to 185°F) |
| Relative humidity: Operating | 5 to 95% (without condensation) |
| Storage | 5 to 85% (without condensation) |
| Conductors Wiring | 14 gauge (2mm ²) stranded (max.) 3/64 inch (1.2mm) insulation (max.) |
| Category | Category 2 ³ |
| Keying | between 10 and 12 between 24 and 26 |
| Wiring Arm | Catalog Number 1771-WG |
| Field Wiring Arm Screw Torque | 7-9 inch-pounds |
| Agency Certification (when product or packaging is marked) | <ul style="list-style-type: none"> •   Class 1 Div 2 Hazardous ⁴ •  marked for all applicable directives |
| User Manual | Publication 1771-6.5.115 |

¹ The inputs are protected to 200V. However, if an input terminal's voltage exceeds $\pm 14.25V$ as referenced to module common, channel-to-channel crosstalk can cause invalid input readings and invalid underrange/overrange bits.

² Only 8 volts can be placed directly across the input when configured in the current mode.

³ Refer to publication 1770-4.1, "Industrial Automation Wiring and Grounding Guidelines for Noise Immunity."

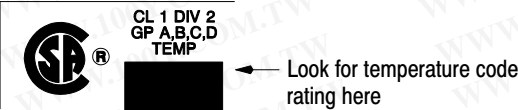
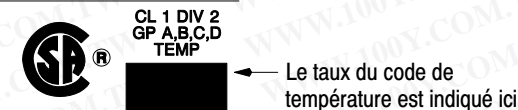
⁴ CSA certification— Class I, Division 2, Group A, B, C, D or nonhazardous locations.

| CSA Hazardous Location Approval | Approbation d'utilisation dans des emplacements dangereux par la CSA |
|--|--|
| <p>CSA certifies products for general use as well as for use in hazardous locations. Actual CSA certification is indicated by the product label as shown below, and not by statements in any user documentation.</p> | <p>La CSA certifie les produits d'utilisation générale aussi bien que ceux qui s'utilisent dans des emplacements dangereux. La certification CSA en vigueur est indiquée par l'étiquette du produit et non par des affirmations dans la documentation à l'usage des utilisateurs.</p> |
| <p>Example of the CSA certification product label</p>  | <p>Exemple d'étiquette de certification d'un produit par la CSA</p>  |
| <p>To comply with CSA certification for use in hazardous locations, the following information becomes a part of the product literature for CSA-certified Allen-Bradley industrial control products.</p> <ul style="list-style-type: none"> • This equipment is suitable for use in Class I, Division 2, Groups A, B, C, D, or non-hazardous locations only. • The products having the appropriate CSA markings (that is, Class I Division 2, Groups A, B, C, D), are certified for use in other equipment where the suitability of combination (that is, application or use) is determined by the CSA or the local inspection office having jurisdiction. | <p>Pour satisfaire à la certification de la CSA dans des endroits dangereux, les informations suivantes font partie intégrante de la documentation des produits industriels de contrôle Allen-Bradley certifiés par la CSA.</p> <ul style="list-style-type: none"> • Cet équipement convient à l'utilisation dans des emplacements de Classe 1, Division 2, Groupes A, B, C, D, ou ne convient qu'à l'utilisation dans des endroits non dangereux. • Les produits portant le marquage approprié de la CSA (c'est à dire, Classe 1, Division 2, Groupes A, B, C, D) sont certifiés à l'utilisation pour d'autres équipements où la convenance de combinaison (application ou utilisation) est déterminée par la CSA ou le bureau local d'inspection qualifié. |
| <p>Important: Due to the modular nature of a PLC[®] control system, the product with the highest temperature rating determines the overall temperature code rating of a PLC control system in a Class I, Division 2 location. The temperature code rating is marked on the product label as shown.</p> | <p>Important: Par suite de la nature modulaire du système de contrôle PLC[®], le produit ayant le taux le plus élevé de température détermine le taux d'ensemble du code de température du système de contrôle d'un PLC dans un emplacement de Classe 1, Division 2. Le taux du code de température est indiqué sur l'étiquette du produit.</p> |
| <p>Temperature code rating</p>  | <p>Taux du code de température</p>  |
| <p>The following warnings apply to products having CSA certification for use in hazardous locations.</p> | <p>Les avertissements suivants s'appliquent aux produits ayant la certification CSA pour leur utilisation dans des emplacements dangereux.</p> |
|  <p>ATTENTION: Explosion hazard —</p> <ul style="list-style-type: none"> • Substitution of components may impair suitability for Class I, Division 2. • Do not replace components unless power has been switched off or the area is known to be non-hazardous. • Do not disconnect equipment unless power has been switched off or the area is known to be non-hazardous. • Do not disconnect connectors unless power has been switched off or the area is known to be non-hazardous. Secure any user-supplied connectors that mate to external circuits on an Allen-Bradley product using screws, sliding latches, threaded connectors, or other means such that any connection can withstand a 15 Newton (3.4 lb.) separating force applied for a minimum of one minute. |  <p>AVERTISSEMENT: Risque d'explosion —</p> <ul style="list-style-type: none"> • La substitution de composants peut rendre ce matériel inacceptable pour les emplacements de Classe 1, Division 2. • Couper le courant ou s'assurer que l'emplacement est désigné non dangereux avant de remplacer les composants. • Avant de débrancher l'équipement, couper le courant ou s'assurer que l'emplacement est désigné non dangereux. • Avant de débrancher les connecteurs, couper le courant ou s'assurer que l'emplacement est reconnu non dangereux. Attacher tous connecteurs fournis par l'utilisateur et reliés aux circuits externes d'un appareil Allen-Bradley à l'aide de vis, loquets coulissants, connecteurs filetés ou autres moyens permettant aux connexions de résister à une force de séparation de 15 newtons (3,4 lb. - 1,5 kg) appliquée pendant au moins une minute. |

PLC est une marque déposée de Allen-Bradley Company, Inc.
 PLC is a registered trademark of Allen-Bradley Company, Inc.
 Le sigle CSA est la marque déposée de l'Association des Standards pour le Canada.
 CSA logo is a registered trademark of the Canadian Standards Association.

Differences Between Series A, B and C Modules

| Feature | Series A, and B | Series C |
|------------------------|--|--|
| Indicator lights | <ol style="list-style-type: none"> At power-up, the green run indicator comes on and stays on. Limited to 3 bits of diagnostic information | <ol style="list-style-type: none"> At powerup, the green run indicator blinks until a configuration BTW is received. After a configuration BTW is received, the green indicator stays on. Has 6 bits of diagnostic information representing 6 possible faults. |
| Input Data | Input clamped at range ends. Will not go above or below range limits. | Returns input data above and below the range end points. For example, a 1–5V input with default scaling will return all values between $\pm 5.2V$. Jumper settable for Series A and B simulation. |
| Default Scaling | | Allows default scaling with both maximum and minimum scaling values as zero. No scaling error will be reported. |
| Block Transfer Lengths | Maximum block transfers lengths of 20 words for BTR and 37 words for BTW. Default length of 0 words. | Maximum block transfers lengths of 22 words for BTR and 39 words for BTW (due to autocalibration). Default length of 0 words (same as series A). |
| Configuration Plugs | 24 configuration plugs to set on 3 row headers. | 16 configuration plugs to set on eight 2 row headers. |
| Compatibility | The series A and B modules are compatible with the 1771-AL PLC local adapter. | The series C module is not compatible with the 1771-AL PLC local adapter. |
| Calibration Procedures | Used jumpers and potentiometers to adjust 10V reference and null input offset. | Uses precision voltage source to supply voltage and a block transfer to set offset and gain. |
| Agency Approvals | Series A module not CE certified. Series B module CE certified. | Series C module CE certified. |

勝特力材料 886-3-5753170
 勝特力电子(上海) 86-21-34970699
 勝特力电子(深圳) 86-755-83298787
[Http://www.100y.com.tw](http://www.100y.com.tw)



Allen-Bradley, a Rockwell Automation Business, has been helping its customers improve productivity and quality for more than 90 years. We design, manufacture and support a broad range of automation products worldwide. They include logic processors, power and motion control devices, operator interfaces, sensors and a variety of software. Rockwell is one of the world's leading technology companies.



Worldwide representation.

Argentina • Australia • Austria • Bahrain • Belgium • Brazil • Bulgaria • Canada • Chile • China, PRC • Colombia • Costa Rica • Croatia • Cyprus • Czech Republic • Denmark • Ecuador • Egypt • El Salvador • Finland • France • Germany • Greece • Guatemala • Honduras • Hong Kong • Hungary • Iceland • India • Indonesia • Ireland • Israel • Italy • Jamaica • Japan • Jordan • Korea • Kuwait • Lebanon • Malaysia • Mexico • Netherlands • New Zealand • Norway • Pakistan • Peru • Philippines • Poland • Portugal • Puerto Rico • Qatar • Romania • Russia-CIS • Saudi Arabia • Singapore • Slovakia • Slovenia • South Africa, Republic • Spain • Sweden • Switzerland • Taiwan • Thailand • Turkey • United Arab Emirates • United Kingdom • United States • Uruguay • Venezuela • Yugoslavia

Allen-Bradley Headquarters, 1201 South Second Street, Milwaukee, WI 53204 USA, Tel: (1) 414 382-2000 Fax: (1) 414 382-4444