

# DATA SHEET

勝特力材料 886-3-5753170  
勝特力电子(上海) 86-21-54151736  
勝特力电子(深圳) 86-755-83298787  
[Http://www.100y.com.tw](http://www.100y.com.tw)

## 74LVC138A

3-to-8 line decoder/demultiplexer;  
inverting

Product specification

1998 Apr 28

# 3-to-8 line decoder/demultiplexer; inverting

# 74LVC138A

## FEATURES

- Wide supply voltage range of 1.2 to 3.6 V
- In accordance with JEDEC standard no. 8-1A
- Inputs accept voltages up to 5.5 V
- CMOS lower power consumption
- Direct interface with TTL levels
- Demultiplexing capability
- Multiple input enable for easy expansion
- Ideal for memory chip select decoding
- Active LOW mutually exclusive outputs
- Output drive capability 50 Ω transmission lines at 85°C

## DESCRIPTION

The 74LVC138A is a low-voltage, low-power, high-performance Si-gate CMOS device, superior to most advanced CMOS compatible TTL families.

The 74LVC138A accepts three binary weighted address inputs ( $A_0$ ,  $A_1$ ,  $A_2$ ) and when enabled, provides 8 mutually exclusive active LOW outputs ( $\bar{Y}_0$  to  $\bar{Y}_7$ ).

The 74LVC138A features three enable inputs: two active LOW ( $\bar{E}_1$  and  $\bar{E}_2$ ) and one active HIGH ( $E_3$ ). Every output will be HIGH unless  $E_1$  and  $E_2$  are LOW and  $E_3$  is HIGH.

This multiple enable function allows easy parallel expansion of the 74LV138A to a 1-of-32 (5 lines to 32 lines) decoder with just four 74LV138A ICs and one inverter. The 74LV138A can be used as an eight output demultiplexer by using one of the active LOW enable inputs as the data input and the remaining enable inputs as strobes. Unused enable inputs must be permanently tied to their appropriate active HIGH or LOW state.

## QUICK REFERENCE DATA

GND = 0 V;  $T_{amb} = 25^\circ\text{C}$ ;  $t_r = t_f \leq 2.5$  ns

SYMBOL	PARAMETER	CONDITIONS	TYPICAL	UNIT
$t_{PHL}/t_{PLH}$	Propagation delay An to $\bar{Y}_n$ , $E_3$ to $\bar{Y}_n$ , $E_n$ to $\bar{Y}_n$	$C_L = 50$ pF; $V_{CC} = 3.3$ V	3.5 3.5	ns
$C_I$	Input capacitance		5.0	pF
$C_{PD}$	Power dissipation capacitance per package	$V_{CC} = 3.3$ V Notes 1 and 2	44	pF

### NOTES:

- $C_{PD}$  is used to determine the dynamic power dissipation ( $P_D$  in  $\mu\text{W}$ )  
 $P_D = C_{PD} \times V_{CC}^2 \times f_i + \sum (C_L \times V_{CC}^2 \times f_o)$  where:  
 $f_i$  = input frequency in MHz;  $C_L$  = output load capacity in pF;  
 $f_o$  = output frequency in MHz;  $V_{CC}$  = supply voltage in V;  
 $\sum (C_L \times V_{CC}^2 \times f_o)$  = sum of the outputs.
- The condition is  $V_I = \text{GND}$  to  $V_{CC}$

**勝特力材料 886-3-5753170**  
**胜特力电子(上海) 86-21-54151736**  
**胜特力电子(深圳) 86-755-83298787**  
[Http://www.100y.com.tw](http://www.100y.com.tw)

## ORDERING INFORMATION

PACKAGES	TEMPERATURE RANGE	OUTSIDE NORTH AMERICA	NORTH AMERICA	PKG. DWG. #
16-Pin Plastic SO	-40°C to +85°C	74LVC138A D	74LVC138A D	SOT109-1
16-Pin Plastic SSOP Type II	-40°C to +85°C	74LVC138A DB	74LVC138A DB	SOT338-1
16-Pin Plastic TSSOP Type I	-40°C to +85°C	74LVC138A PW	74LVC138APW DH	SOT403-1

## PIN CONFIGURATION

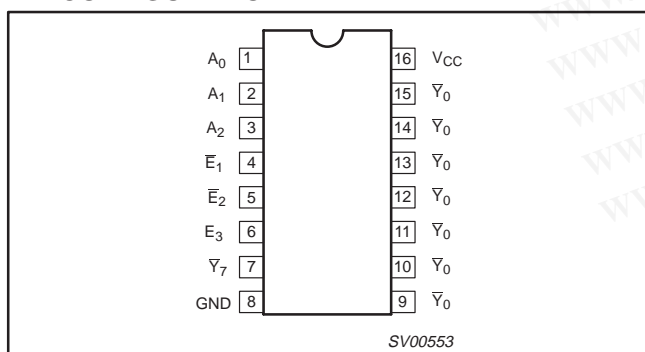

## LOGIC DIAGRAM

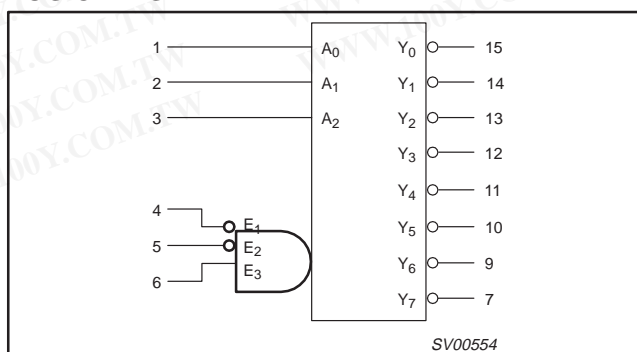

# 3-to-8 line decoder/demultiplexer; inverting

# 74LVC138A

### PIN DESCRIPTION

PIN NUMBER	SYMBOL	NAME AND FUNCTION
1, 2, 3	$A_0$ to $A_2$	Address inputs
4, 5	$\bar{E}_1, \bar{E}_2$	Enable inputs (active LOW)
6	$E_3$	Enable inputs (active HIGH)
15, 14, 13, 12, 11, 10, 9, 7	$\bar{Y}_0$ to $\bar{Y}_7$	Outputs
8	GND	Ground (0 V)
16	$V_{CC}$	Positive supply voltage

### FUNCTIONAL DIAGRAM

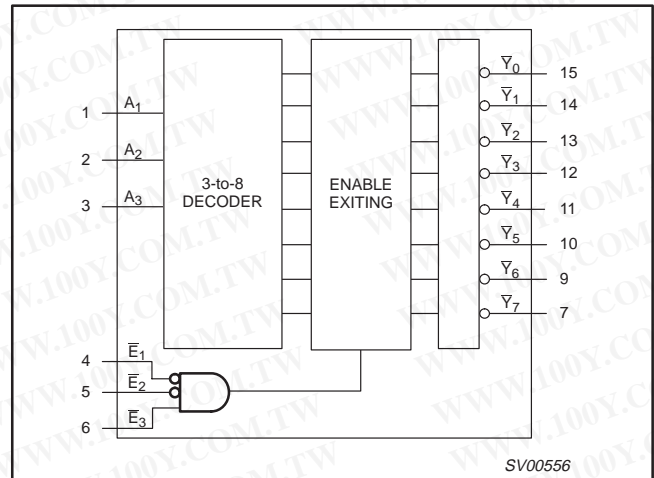

### LOGIC SYMBOL (IEEE/IEC)

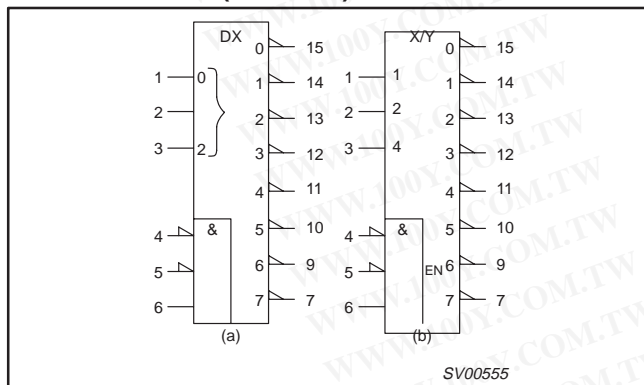

**勝特力材料 886-3-5753170**  
**勝特力电子(上海) 86-21-54151736**  
**勝特力电子(深圳) 86-755-83298787**  
[Http://www.100y.com.tw](http://www.100y.com.tw)

### FUNCTION TABLE

INPUTS						OUTPUTS							
$\bar{E}_1$	$\bar{E}_2$	$E_3$	$A_0$	$A_1$	$A_2$	$\bar{Y}_0$	$\bar{Y}_1$	$\bar{Y}_2$	$\bar{Y}_3$	$\bar{Y}_4$	$\bar{Y}_5$	$\bar{Y}_6$	$\bar{Y}_7$
H	X	X	X	X	X	H	H	H	H	H	H	H	H
X	H	X	X	X	X	H	H	H	H	H	H	H	H
X	X	L	X	X	X	H	H	H	H	H	H	H	H
L	L	H	L	L	L	L	H	H	H	H	H	H	H
L	L	H	H	L	L	H	L	H	H	H	H	H	H
L	L	H	L	H	L	H	H	L	H	H	H	H	H
L	L	H	H	H	L	H	H	H	H	L	H	H	H
L	L	H	H	L	H	H	H	H	H	H	L	H	H
L	L	H	L	H	H	H	H	H	H	H	H	L	H
L	L	H	H	H	H	H	H	H	H	H	H	H	L

#### NOTES:

H = HIGH voltage level  
 L = LOW voltage level  
 X = don't care

## 3-to-8 line decoder/demultiplexer; inverting

74LVC138A

## RECOMMENDED OPERATING CONDITIONS

SYMBOL	PARAMETER	CONDITIONS	LIMITS		UNIT
			MIN	MAX	
$V_{CC}$	DC supply voltage (for max. speed performance)		2.7	3.6	V
	DC supply voltage (for low-voltage applications)		1.2	3.6	
$V_I$	DC input voltage range		0	5.5	V
$V_{I/O}$	DC output voltage range; output HIGH or LOW state		0	$V_{CC}$	V
	DC input voltage range; output 3-State		0	5.5	
$T_{amb}$	Operating free-air temperature range		-40	+85	°C
$t_r, t_f$	Input rise and fall times	$V_{CC} = 1.2$ to $2.7V$ $V_{CC} = 2.7$ to $3.6V$	0	20 10	ns/V

ABSOLUTE MAXIMUM RATINGS<sup>1</sup>

In accordance with the Absolute Maximum Rating System (IEC 134).  
Voltages are referenced to GND (ground = 0V).

SYMBOL	PARAMETER	CONDITIONS	RATING	UNIT
$V_{CC}$	DC supply voltage		-0.5 to +6.5	V
$I_{IK}$	DC input diode current	$V_I < 0$	-50	mA
$V_I$	DC input voltage	Note 2	-0.5 to +6.5	V
$I_{OK}$	DC output diode current	$V_O > V_{CC}$ or $V_O < 0$	± 50	mA
$V_{I/O}$	DC output voltage; output HIGH or LOW	Note 2	-0.5 to $V_{CC} + 0.5$	V
	DC input voltage; output 3-State	Note 2	-0.5 to 6.5	
$I_O$	DC output source or sink current	$V_O = 0$ to $V_{CC}$	± 50	mA
$I_{GND}, I_{CC}$	DC $V_{CC}$ or GND current		± 100	mA
$T_{stg}$	Storage temperature range		-65 to +150	°C
$P_{TOT}$	Power dissipation per package			
	- plastic mini-pack (SO) - plastic shrink mini-pack (SSOP and TSSOP)	above +70°C derate linearly with 8 mW/K above +60°C derate linearly with 5.5 mW/K	500 500	mW

## NOTES:

- Stresses beyond those listed may cause permanent damage to the device. These are stress ratings only and functional operation of the device at these or any other conditions beyond those indicated under "recommended operating conditions" is not implied. Exposure to absolute-maximum-rated conditions for extended periods may affect device reliability.
- The input and output voltage ratings may be exceeded if the input and output current ratings are observed.

勝特力材料 886-3-5753170  
 勝特力电子(上海) 86-21-54151736  
 勝特力电子(深圳) 86-755-83298787  
[Http://www.100y.com.tw](http://www.100y.com.tw)

## 3-to-8 line decoder/demultiplexer; inverting

## 74LVC138A

**DC ELECTRICAL CHARACTERISTICS**

Over recommended operating conditions. Voltages are referenced to GND (ground = 0V).

SYMBOL	PARAMETER	TEST CONDITIONS	LIMITS			UNIT
			Temp = -40°C to +85°C			
			MIN	TYP <sup>1</sup>	MAX	
V <sub>IH</sub>	HIGH level input voltage	V <sub>CC</sub> = 1.2V	V <sub>CC</sub>			V
		V <sub>CC</sub> = 2.7 to 3.6V	2.0			
V <sub>IL</sub>	LOW level input voltage	V <sub>CC</sub> = 1.2V			GND	V
		V <sub>CC</sub> = 2.7 to 3.6V			0.8	
V <sub>OH</sub>	HIGH level output voltage	V <sub>CC</sub> = 2.7V; V <sub>I</sub> = V <sub>IH</sub> or V <sub>IL</sub> ; I <sub>O</sub> = -12mA	V <sub>CC</sub> - 0.5			V
		V <sub>CC</sub> = 3.0V; V <sub>I</sub> = V <sub>IH</sub> or V <sub>IL</sub> ; I <sub>O</sub> = -100μA	V <sub>CC</sub> - 0.2	V <sub>CC</sub>		
		V <sub>CC</sub> = 3.0V; V <sub>I</sub> = V <sub>IH</sub> or V <sub>IL</sub> ; I <sub>O</sub> = -12mA	V <sub>CC</sub> - 0.6			
		V <sub>CC</sub> = 3.0V; V <sub>I</sub> = V <sub>IH</sub> or V <sub>IL</sub> ; I <sub>O</sub> = -24mA	V <sub>CC</sub> - 1.0			
V <sub>OL</sub>	LOW level output voltage	V <sub>CC</sub> = 2.7V; V <sub>I</sub> = V <sub>IH</sub> or V <sub>IL</sub> ; I <sub>O</sub> = 12mA			0.40	V
		V <sub>CC</sub> = 3.0V; V <sub>I</sub> = V <sub>IH</sub> or V <sub>IL</sub> ; I <sub>O</sub> = 100μA		GND	0.20	
		V <sub>CC</sub> = 3.0V; V <sub>I</sub> = V <sub>IH</sub> or V <sub>IL</sub> ; I <sub>O</sub> = 24mA			0.55	
I <sub>I</sub>	Input leakage current	V <sub>CC</sub> = 3.6V; V <sub>I</sub> = 5.5V or GND		±0.1	±5	μA
I <sub>CC</sub>	Quiescent supply current	V <sub>CC</sub> = 3.6V; V <sub>I</sub> = V <sub>CC</sub> or GND; I <sub>O</sub> = 0		0.1	10	μA
ΔI <sub>CC</sub>	Additional quiescent supply current per input pin	V <sub>CC</sub> = 2.7V to 3.6V; V <sub>I</sub> = V <sub>CC</sub> - 0.6V; I <sub>O</sub> = 0		5	500	μA

**NOTE:**1. All typical values are at V<sub>CC</sub> = 3.3V and T<sub>amb</sub> = 25°C.**AC CHARACTERISTICS**GND = 0 V; t<sub>r</sub> = t<sub>f</sub> ≤ 2.5 ns; C<sub>L</sub> = 50 pF; R<sub>L</sub> = 500Ω; T<sub>amb</sub> = -40°C to +85°C

SYMBOL	PARAMETER	WAVEFORM	LIMITS					UNIT
			V <sub>CC</sub> = 3.3V ±0.3V			V <sub>CC</sub> = 2.7V		
			MIN	TYP <sup>1</sup>	MAX	MIN	MAX	
t <sub>PHL</sub> /t <sub>PLH</sub>	Propagation delay A <sub>n</sub> to $\bar{Y}_n$	Figure 1, 3	1.5	3.5	5.8	1.5	6.8	ns
t <sub>PHL</sub> /t <sub>PLH</sub>	Propagation delay E <sub>3</sub> to $\bar{Y}_n$	Figure 1, 3	1.5	3.6	5.8	1.5	6.8	ns
t <sub>PHL</sub> /t <sub>PLH</sub>	Propagation delay E <sub>n</sub> to $\bar{Y}_n$	Figure 2, 3	1.5	3.5	5.8	1.5	6.8	ns

**NOTE:**1. These typical values are at V<sub>CC</sub> = 3.3V and T<sub>amb</sub> = 25°C.

勝特力材料 886-3-5753170  
 勝特力电子(上海) 86-21-54151736  
 勝特力电子(深圳) 86-755-83298787  
 Http://www.100y.com.tw

# 3-to-8 line decoder/demultiplexer; inverting

# 74LVC138A

### AC WAVEFORMS

$V_M = 1.5\text{ V}$  at  $V_{CC} \geq 2.7\text{ V}$

$V_M = 0.5 \cdot V_{CC}$  at  $V_{CC} < 2.7\text{ V}$

$V_{OL}$  and  $V_{OH}$  are the typical output voltage drop that occur with the output load.

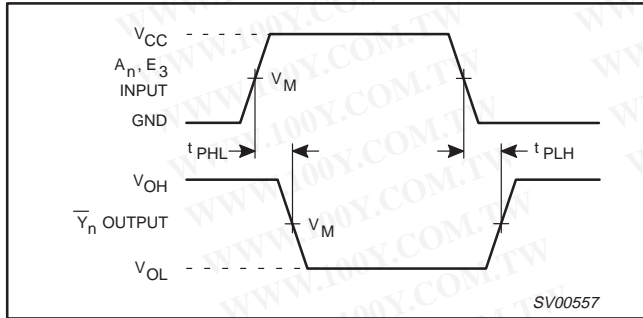

Figure 1. Input (nA) to output (nY) propagation delays.

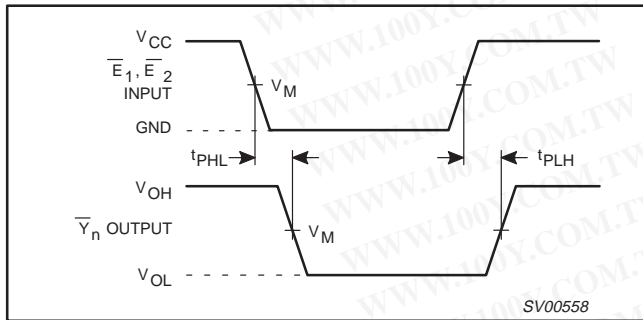

Figure 2. 3-State enable and disable times.

### TEST CIRCUIT

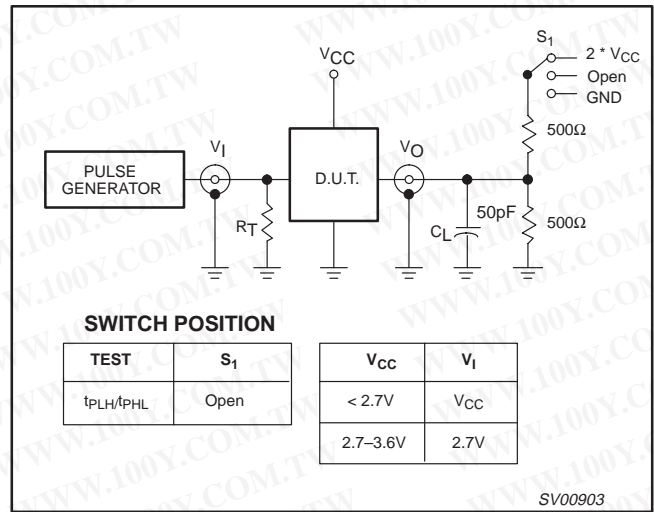

Figure 3. Load circuitry for switching times.

勝特力材料 886-3-5753170  
 勝特力电子(上海) 86-21-54151736  
 勝特力电子(深圳) 86-755-83298787  
[Http://www.100y.com.tw](http://www.100y.com.tw)

3-to-8 line decoder/demultiplexer; inverting

74LVC138A

SO16: plastic small outline package; 16 leads; body width 3.9 mm

SOT109-1

勝特力材料 886-3-5753170  
 勝特力电子(上海) 86-21-54151736  
 勝特力电子(深圳) 86-755-83298787  
[Http://www.100y.com.tw](http://www.100y.com.tw)

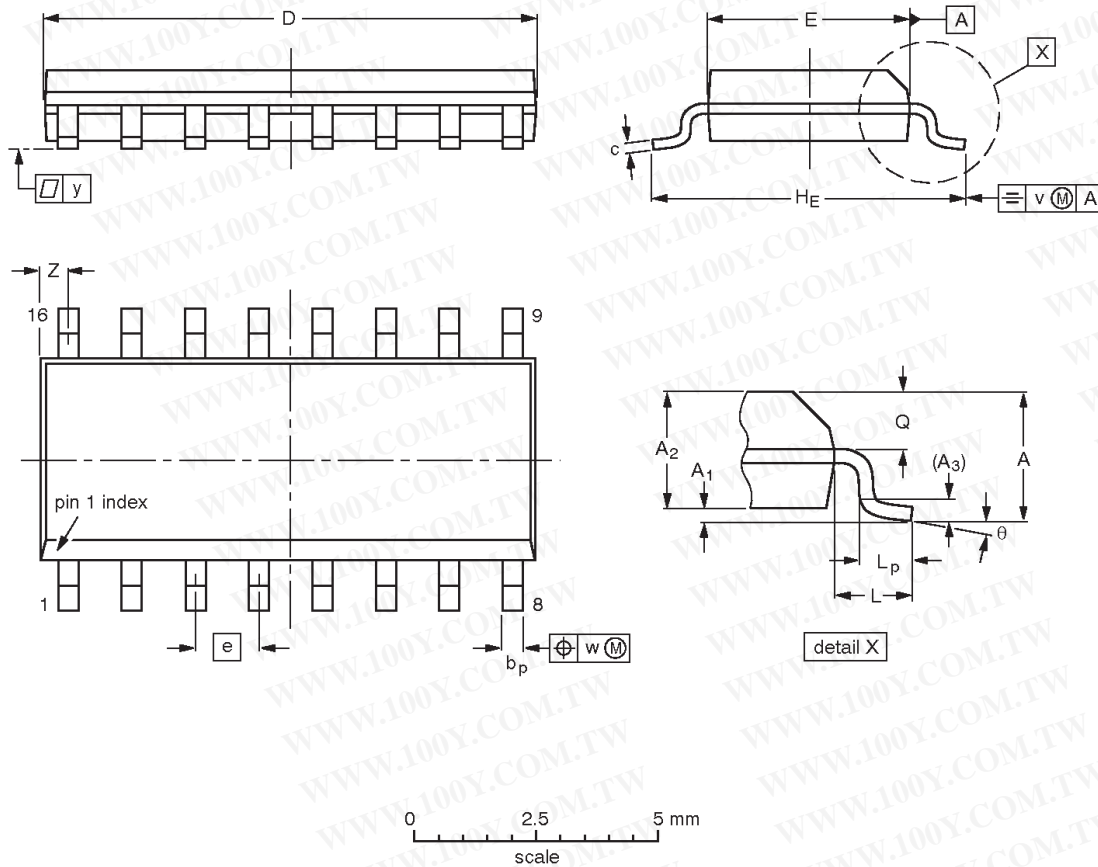

**DIMENSIONS (inch dimensions are derived from the original mm dimensions)**

UNIT	A max.	A <sub>1</sub>	A <sub>2</sub>	A <sub>3</sub>	b <sub>p</sub>	c	D <sup>(1)</sup>	E <sup>(1)</sup>	e	H <sub>E</sub>	L	L <sub>p</sub>	Q	v	w	y	Z <sup>(1)</sup>	$\theta$
mm	1.75	0.25 0.10	1.45 1.25	0.25	0.49 0.36	0.25 0.19	10.0 9.8	4.0 3.8	1.27	6.2 5.8	1.05	1.0 0.4	0.7 0.6	0.25	0.25	0.1	0.7 0.3	8° 0°
inches	0.069	0.010 0.004	0.057 0.049	0.01	0.019 0.014	0.0100 0.0075	0.39 0.38	0.16 0.15	0.050	0.244 0.228	0.041	0.039 0.016	0.028 0.020	0.01	0.01	0.004	0.028 0.012	

**Note**

1. Plastic or metal protrusions of 0.15 mm maximum per side are not included.

OUTLINE VERSION	REFERENCES			EUROPEAN PROJECTION	ISSUE DATE
	IEC	JEDEC	EIAJ		
SOT109-1	076E07S	MS-012AC			95-01-23 97-05-22

3-to-8 line decoder/demultiplexer; inverting

74LVC138A

SSOP16: plastic shrink small outline package; 16 leads; body width 5.3 mm

SOT338-1

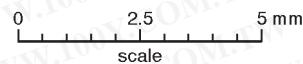
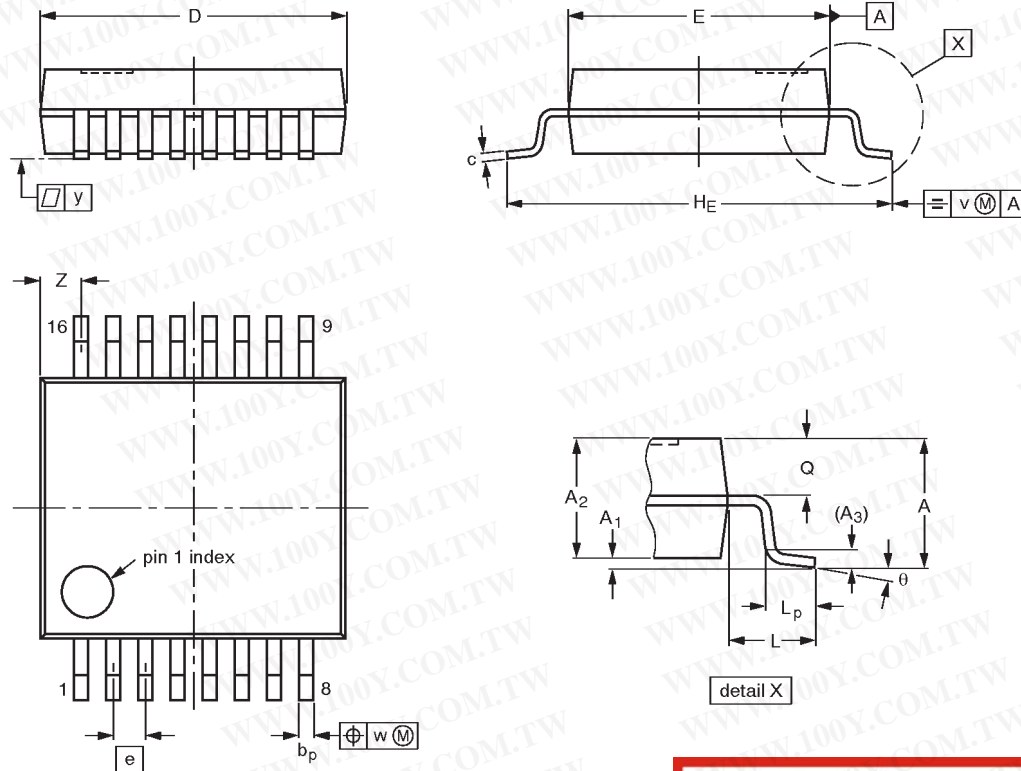

勝特力材料 886-3-5753170  
 勝特力电子(上海) 86-21-54151736  
 勝特力电子(深圳) 86-755-83298787  
[Http://www.100y.com.tw](http://www.100y.com.tw)

DIMENSIONS (mm are the original dimensions)

UNIT	A max.	A <sub>1</sub>	A <sub>2</sub>	A <sub>3</sub>	b <sub>p</sub>	c	D <sup>(1)</sup>	E <sup>(1)</sup>	e	H <sub>E</sub>	L	L <sub>p</sub>	Q	v	w	y	Z <sup>(1)</sup>	θ
mm	2.0	0.21 0.05	1.80 1.65	0.25	0.38 0.25	0.20 0.09	6.4 6.0	5.4 5.2	0.65	7.9 7.6	1.25	1.03 0.63	0.9 0.7	0.2	0.13	0.1	1.00 0.55	8° 0°

Note

1. Plastic or metal protrusions of 0.25 mm maximum per side are not included.

OUTLINE VERSION	REFERENCES				EUROPEAN PROJECTION	ISSUE DATE
	IEC	JEDEC	EIAJ			
SOT338-1		MO-150AC				94-01-14 95-02-04

# 3-to-8 line decoder/demultiplexer; inverting

# 74LVC138A

TSSOP16: plastic thin shrink small outline package; 16 leads; body width 4.4 mm

SOT403-1

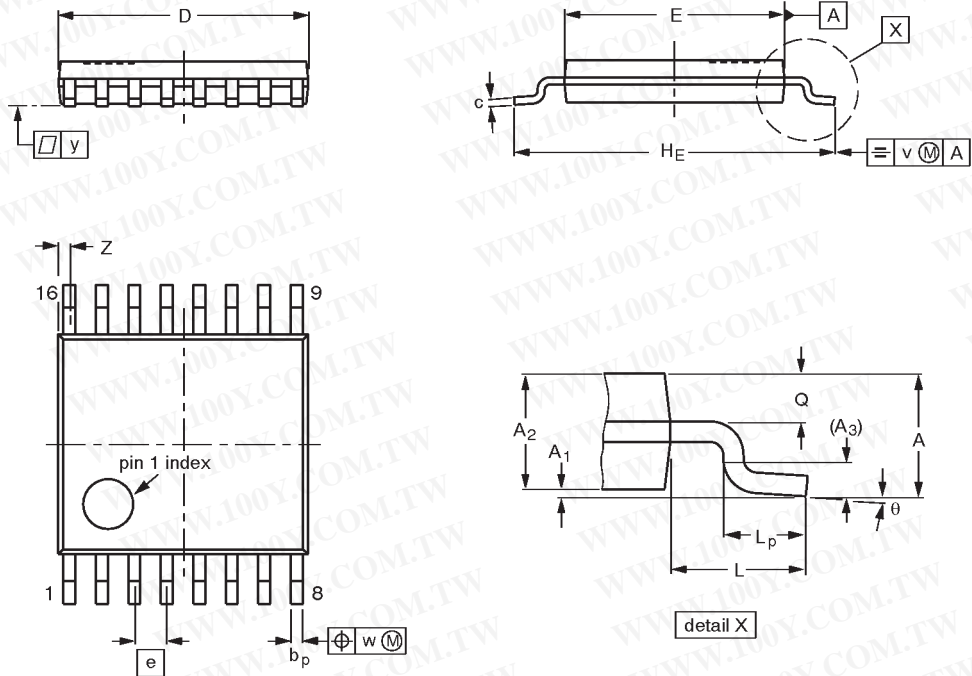

勝特力材料 886-3-5753170  
 勝特力电子(上海) 86-21-54151736  
 勝特力电子(深圳) 86-755-83298787  
[Http://www.100y.com.tw](http://www.100y.com.tw)

**DIMENSIONS (mm are the original dimensions)**

UNIT	A max.	A <sub>1</sub>	A <sub>2</sub>	A <sub>3</sub>	b <sub>p</sub>	c	D <sup>(1)</sup>	E <sup>(2)</sup>	e	H <sub>E</sub>	L	L <sub>p</sub>	Q	v	w	y	Z <sup>(1)</sup>	θ
mm	1.10	0.15 0.05	0.95 0.80	0.25	0.30 0.19	0.2 0.1	5.1 4.9	4.5 4.3	0.65	6.6 6.2	1.0	0.75 0.50	0.4 0.3	0.2	0.13	0.1	0.40 0.06	8° 0°

**Notes**

1. Plastic or metal protrusions of 0.15 mm maximum per side are not included.
2. Plastic interlead protrusions of 0.25 mm maximum per side are not included.

OUTLINE VERSION	REFERENCES				EUROPEAN PROJECTION	ISSUE DATE
	IEC	JEDEC	EIAJ			
SOT403-1		MO-153				94-07-12 95-04-04

## 3-to-8 line decoder/demultiplexer; inverting

74LVC138A

勝特力材料 886-3-5753170  
 胜特力电子(上海) 86-21-54151736  
 胜特力电子(深圳) 86-755-83298787  
[Http://www.100y.com.tw](http://www.100y.com.tw)

## Data sheet status

Data sheet status	Product status	Definition [1]
Objective specification	Development	This data sheet contains the design target or goal specifications for product development. Specification may change in any manner without notice.
Preliminary specification	Qualification	This data sheet contains preliminary data, and supplementary data will be published at a later date. Philips Semiconductors reserves the right to make changes at any time without notice in order to improve design and supply the best possible product.
Product specification	Production	This data sheet contains final specifications. Philips Semiconductors reserves the right to make changes at any time without notice in order to improve design and supply the best possible product.

[1] Please consult the most recently issued datasheet before initiating or completing a design.

## Definitions

**Short-form specification** — The data in a short-form specification is extracted from a full data sheet with the same type number and title. For detailed information see the relevant data sheet or data handbook.

**Limiting values definition** — Limiting values given are in accordance with the Absolute Maximum Rating System (IEC 134). Stress above one or more of the limiting values may cause permanent damage to the device. These are stress ratings only and operation of the device at these or at any other conditions above those given in the Characteristics sections of the specification is not implied. Exposure to limiting values for extended periods may affect device reliability.

**Application information** — Applications that are described herein for any of these products are for illustrative purposes only. Philips Semiconductors make no representation or warranty that such applications will be suitable for the specified use without further testing or modification.

## Disclaimers

**Life support** — These products are not designed for use in life support appliances, devices or systems where malfunction of these products can reasonably be expected to result in personal injury. Philips Semiconductors customers using or selling these products for use in such applications do so at their own risk and agree to fully indemnify Philips Semiconductors for any damages resulting from such application.

**Right to make changes** — Philips Semiconductors reserves the right to make changes, without notice, in the products, including circuits, standard cells, and/or software, described or contained herein in order to improve design and/or performance. Philips Semiconductors assumes no responsibility or liability for the use of any of these products, conveys no license or title under any patent, copyright, or mask work right to these products, and makes no representations or warranties that these products are free from patent, copyright, or mask work right infringement, unless otherwise specified.

Philips Semiconductors  
 811 East Arques Avenue  
 P.O. Box 3409  
 Sunnyvale, California 94088-3409  
 Telephone 800-234-7381

© Copyright Philips Electronics North America Corporation 1998  
 All rights reserved. Printed in U.S.A.

print code

Date of release: 07-98

Document order number:

9397-750-04493

*Let's make things better.*