

DATA SHEET

For a complete data sheet, please also download:

- The IC06 74HC/HCT/HCU/HCMOS Logic Family Specifications
- The IC06 74HC/HCT/HCU/HCMOS Logic Package Information
- The IC06 74HC/HCT/HCU/HCMOS Logic Package Outlines

勝特力材料 886-3-5753170
勝特力电子(上海) 86-21-54151736
勝特力电子(深圳) 86-755-83298787
[Http://www.100y.com.tw](http://www.100y.com.tw)

74HC/HCT4538

Dual retriggerable precision
monostable multivibrator

Product specification
File under Integrated Circuits, IC06

September 1993

Dual retriggerable precision monostable multivibrator

74HC/HCT4538

FEATURES

- Separate reset inputs
- Triggering from leading or trailing edge
- Output capability: standard
- I_{CC} category: MSI
- Power-on reset on-chip

GENERAL DESCRIPTION

The 74HC/HCT4538 are high-speed Si-gate CMOS devices and are pin compatible with "4538" of the "4000B" series. They are specified in compliance with JEDEC standard no. 7A.

The 74HC/HCT4538 are dual retriggerable-resettable monostable multivibrators. Each multivibrator has an active LOW trigger/retrigger input ($\overline{nA_0}$), an active HIGH

trigger/retrigger input (nA_1), an overriding active LOW direct reset input ($\overline{nR_D}$), an output (nQ) and its complement (\overline{nQ}), and two pins (nC_{TC} and nR_{TC}) for connecting the external timing components C_t and R_t . Typical pulse width variation over temperature range is $\pm 0.2\%$.

The "4538" may be triggered by either the positive or the negative edges of the input pulse. The duration and accuracy of the output pulse are determined by the external timing components C_t and R_t . The output pulse width (T) is equal to $0.7 \times R_t \times C_t$. The linear design techniques guarantee precise control of the output pulse width.

A LOW level at $\overline{nR_D}$ terminates the output pulse immediately.

Schmitt-trigger action in the trigger inputs makes the circuit highly tolerant to slower rise and fall times.

QUICK REFERENCE DATA

GND = 0 V; T_{amb} = 25 °C; t_r = t_f = 6 ns

SYMBOL	PARAMETER	CONDITIONS	TYPICAL		UNIT
			HC	HCT	
t _{PHL} / t _{PLH}	propagation delay $\overline{nA_0}$, nA_1 to nQ , \overline{nQ}	C _L = 15 pF; V _{CC} = 5 V	27	30	ns
C _I	input capacitance		3.5	3.5	pF
C _{PD}	power dissipation capacitance per multivibrator	notes 1 and 2	136	138	pF

Notes

1. C_{PD} is used to determine the dynamic power dissipation (P_D in μ W):

$$P_D = C_{PD} \times V_{CC}^2 \times f_i + \sum (C_L \times V_{CC}^2 \times f_o) + 0.48 \times C_{EXT} \times V_{CC}^2 \times f_o + D \times 0.8 \times V_{CC} \text{ where:}$$

f_i = input frequency in MHz

f_o = output frequency in MHz

$\sum (C_L \times V_{CC}^2 \times f_o)$ = sum of outputs

C_L = output load capacitance in pF

V_{CC} = supply voltage in V

D = duty factor in %

C_{EXT} = timing capacitance in pF

2. For HC the condition is V_I = GND to V_{CC}
For HCT the condition is V_I = GND to V_{CC} - 1.5 V

ORDERING INFORMATION

See "74HC/HCT/HCU/HCMOS Logic Package Information".

勝特力材料 886-3-5753170
 勝特力电子(上海) 86-21-54151736
 勝特力电子(深圳) 86-755-83298787
[Http://www.100y.com.tw](http://www.100y.com.tw)

Dual retriggerable precision monostable multivibrator

74HC/HCT4538

PIN DESCRIPTION

PIN NO.	SYMBOL	NAME AND FUNCTION
1, 15	1C _{TC} , 2C _{TC}	external capacitor connections
2, 14	1RC _{TC} , 2RC _{TC}	external resistor/capacitor connections
3, 13	1R _D , 2R _D	direct reset inputs (active LOW)
4, 12	1A ₁ , 2A ₁	trigger inputs (LOW-to-HIGH, edge-triggered)
5, 11	1A ₀ , 2A ₀	trigger inputs (HIGH-to-LOW, edge-triggered)
6, 10	1Q, 2Q	pulse outputs
7, 9	1Q̄, 2Q̄	complementary pulse outputs
8	GND	ground (0 V)
16	V _{CC}	positive supply voltage

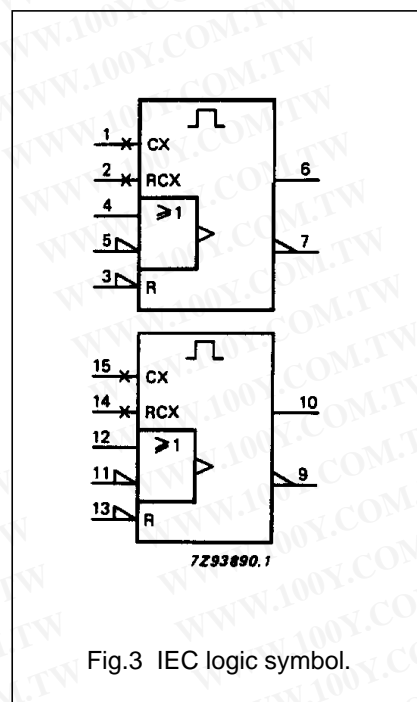
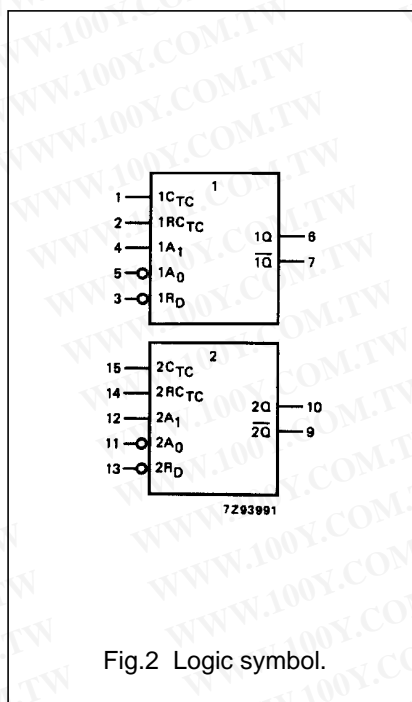
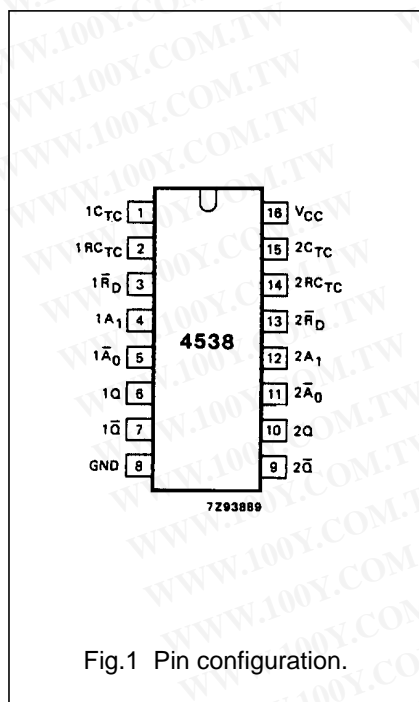

勝特力材料 886-3-5753170
 勝特力电子(上海) 86-21-54151736
 勝特力电子(深圳) 86-755-83298787
[Http://www.100y.com.tw](http://www.100y.com.tw)

Dual retriggerable precision monostable multivibrator

74HC/HCT4538

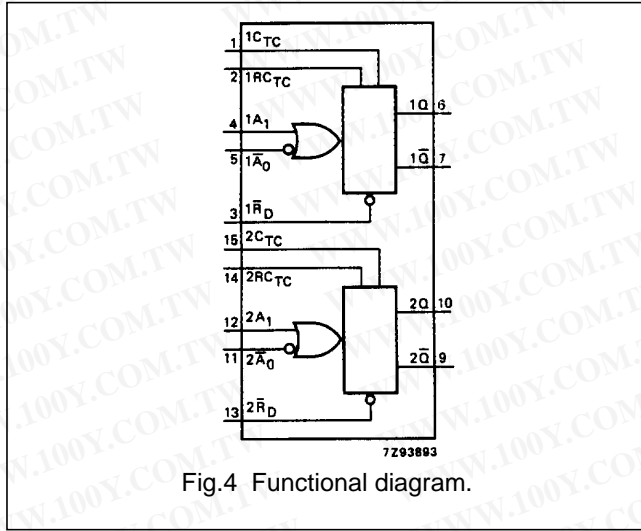

FUNCTION TABLE

INPUTS			OUTPUTS	
$n\bar{A}_0$	nA_1	$n\bar{R}_D$	nQ	$n\bar{Q}$
↓	L	H		
H	↑	H		
X	X	L	L	H

Notes

- H = HIGH voltage level
L = LOW voltage level
X = don't care
↑ = LOW-to-HIGH transition
↓ = HIGH-to-LOW transition
 = one HIGH level output pulse
 = one LOW level output pulse

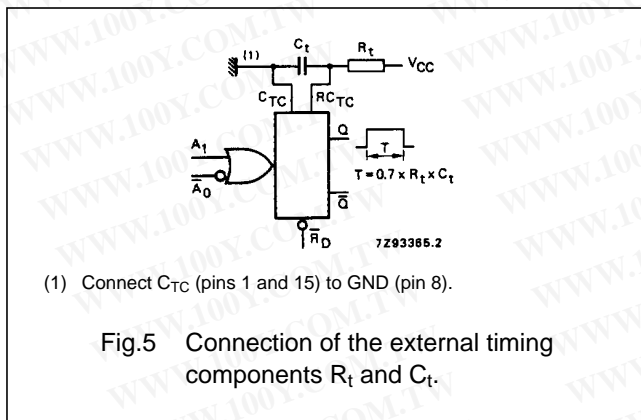

勝特力材料 886-3-5753170
 勝特力电子(上海) 86-21-54151736
 勝特力电子(深圳) 86-755-83298787
[Http://www.100y.com.tw](http://www.100y.com.tw)

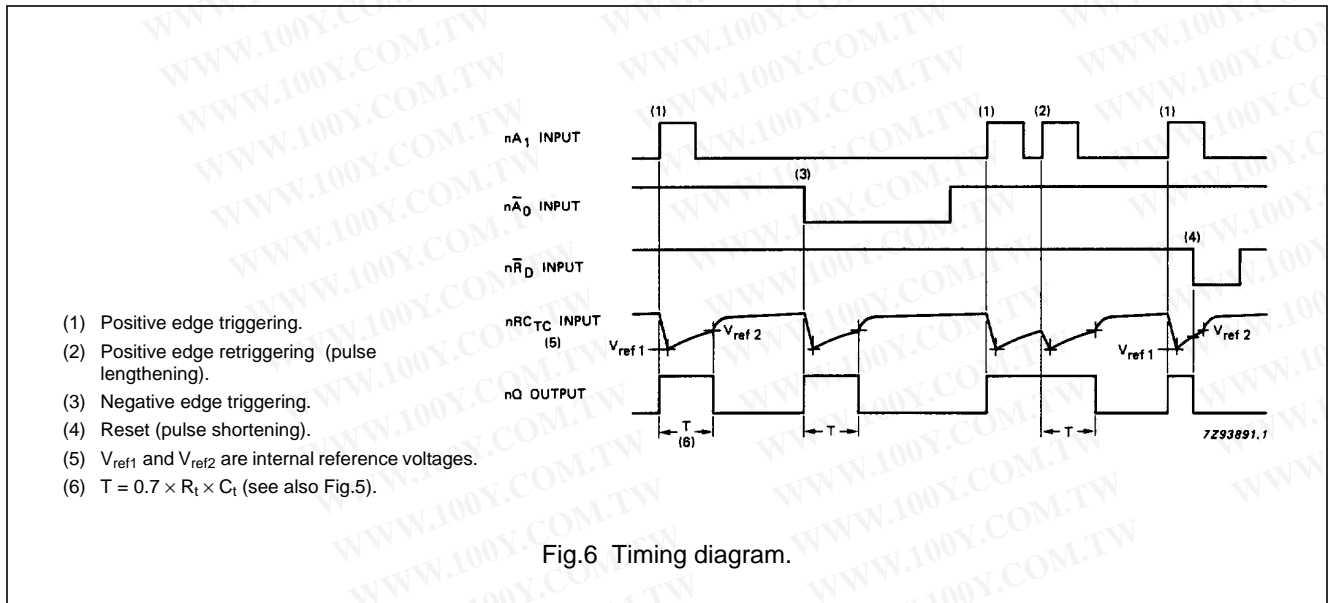

Dual retriggerable precision monostable multivibrator

74HC/HCT4538

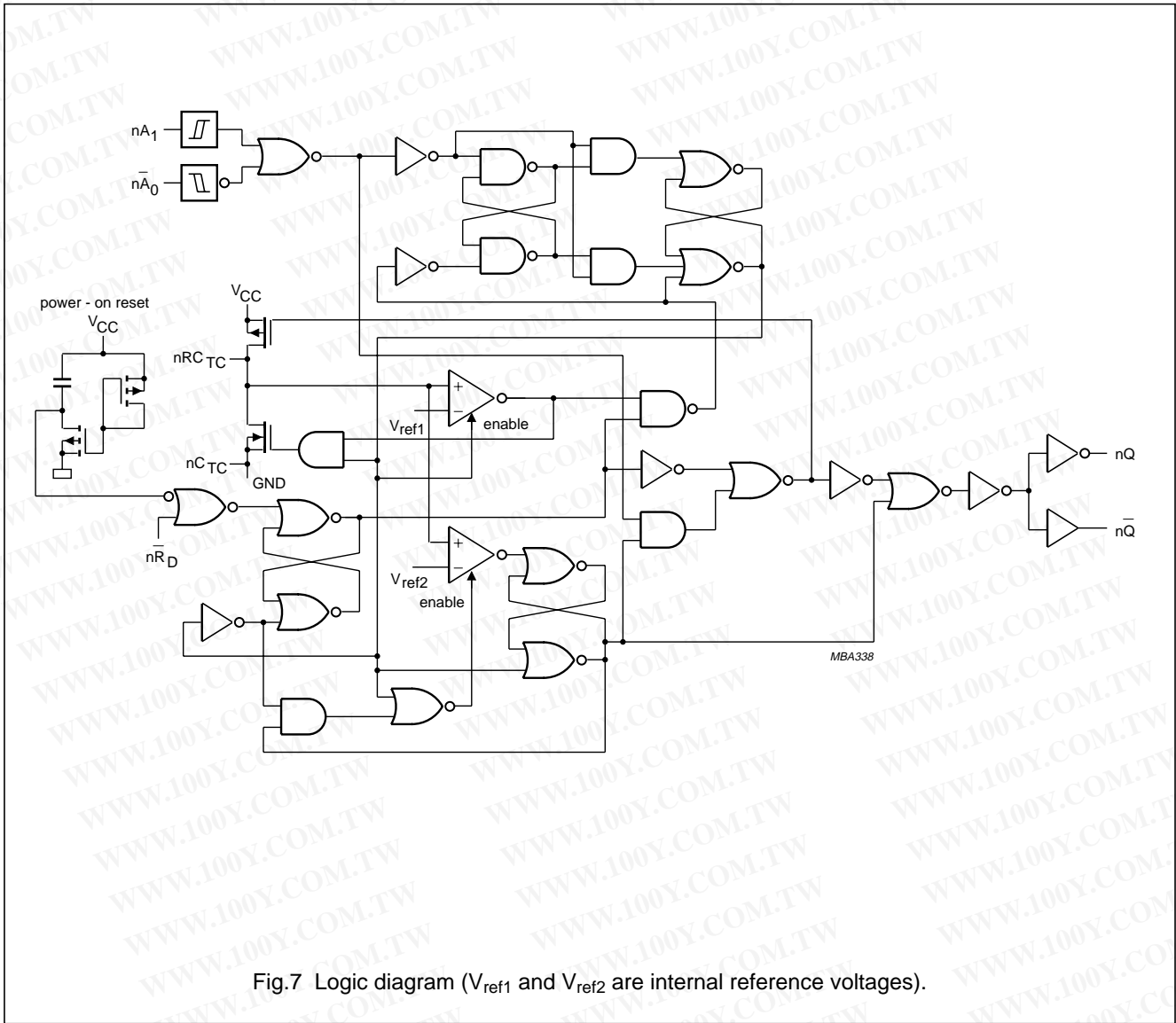

勝特力材料 886-3-5753170
 勝特力电子(上海) 86-21-54151736
 勝特力电子(深圳) 86-755-83298787
[Http://www.100y.com.tw](http://www.100y.com.tw)

Dual retriggerable precision monostable
multivibrator

74HC/HCT4538

DC CHARACTERISTICS FOR 74HC

For the DC characteristics see "74HC/HCT/HCU/HCMOS Logic Family Specifications".

Output capability: standard

I_{CC} category: MSI

AC CHARACTERISTICS FOR 74HC

GND = 0 V; t_r = t_f = 6 ns; C_L = 50 pF

勝特力材料 886-3-5753170
 勝特力电子(上海) 86-21-54151736
 勝特力电子(深圳) 86-755-83298787
[Http://www.100y.com.tw](http://www.100y.com.tw)

SYMBOL	PARAMETER	T _{amb} (°C)						UNIT	TEST CONDITIONS				
		74HC							V _{CC} (V)	OTHER			
		+25			-40 to +85		-40 to +125						
		min.	typ.	max.	min.	max.	min.				max.		
t _{PLH}	propagation delay nA ₀ , nA ₁ to nQ	85	31	265	53	330	66	400	80	68	ns	2.0	Fig.8
t _{PHL}	propagation delay nA ₀ , nA ₁ to nQ̄	83	30	265	53	330	66	400	80	68	ns	2.0	Fig.8
t _{PHL}	propagation delay nR _D to nQ	80	29	265	53	330	66	400	80	68	ns	2.0	Fig.8
t _{PLH}	propagation delay nR _D to nQ̄	83	30	265	53	340	68	400	80	68	ns	2.0	Fig.8
t _{THL} / t _{TLH}	output transition time	19	7	75	15	95	19	110	22	19	ns	2.0	Fig.8
t _w	nA ₀ pulse width LOW	80	16	17	6	100	20	120	24	20	ns	2.0	Fig.8
t _w	nA ₁ pulse width HIGH	80	16	17	6	100	20	120	24	20	ns	2.0	Fig.8
t _w	nR _D pulse width LOW	80	16	19	7	100	20	120	24	20	ns	2.0	Fig.8
t _w	nQ, nQ̄ pulse width HIGH or LOW	0.63	0.70	0.77	0.602	0.798	0.595	0.805			ms	5.0	Fig.8; R _t = 10 kΩ; C _t = 0.1 μF
t _{rem}	removal time R _D to nA ₀ , nA ₁	35	7	6	2	45	9	55	11	9	ns	2.0	Fig.8

Dual retriggerable precision monostable
multivibrator

74HC/HCT4538

SYMBOL	PARAMETER	T _{amb} (°C)							UNIT	TEST CONDITIONS	
		74HC								V _{CC} (V)	OTHER
		+25			-40 to +85		-40 to +125				
		min.	typ.	max.	min.	max.	min.	max.			
t _{rt}	retrigger time nA ₀ , nA ₁	–	455+X	–	–	–	–	ns	2.0 4.5 6.0	Fig.8 X = C _{EXT} / (4.5 × V _{CC})	
R _{EXT}	external timing resistor	10 2	1000 1000					kΩ	2.0 5.0		
C _{EXT}	external timing capacitor	no limits							pF	5.0	

NON-STANDARD DC CHARACTERISTICS FOR 74HC

Voltages are referenced to GND (ground = 0 V)

SYMBOL	PARAMETER	T _{amb} (°C)							UNIT	TEST CONDITIONS		
		74HC								V _{CC} (V)	V _I (V)	OTHER
		+25			-40 to +85		-40 to +125					
		min.	typ.	max.	min.	max.	min.	max.				
±I _i	input leakage current nRC _{EXT}			0.5		5.0		10.0	μA	6.0	2.0 or GND	V _{CC} or GND; note 1

Note

1. This measurement can only be carried out after a trigger pulse is applied.

勝特力材料 886-3-5753170
 勝特力电子(上海) 86-21-54151736
 勝特力电子(深圳) 86-755-83298787
[Http://www.100y.com.tw](http://www.100y.com.tw)

Dual retriggerable precision monostable multivibrator

74HC/HCT4538

DC CHARACTERISTICS FOR 74HCT

For the DC characteristics see *"74HC/HCT/HCU/HCMOS Logic Family Specifications"*.

Output capability: standard

I_{CC} category: MSI

Note to HCT types

The value of additional quiescent supply current (ΔI_{CC}) for a unit load of 1 is given in the family specifications.

To determine ΔI_{CC} per input, multiply this value by the unit load coefficient shown in the table below.

INPUT	UNIT LOAD COEFFICIENT
$\overline{nA_0}$, nA_1	0.50
nR_D	0.65

勝特力材料 886-3-5753170
 勝特力电子(上海) 86-21-54151736
 勝特力电子(深圳) 86-755-83298787
[Http://www.100y.com.tw](http://www.100y.com.tw)

AC CHARACTERISTICS FOR 74HCT

GND = 0 V; $t_r = t_f = 6$ ns; $C_L = 50$ pF

SYMBOL	PARAMETER	T _{amb} (°C)								UNIT	TEST CONDITIONS		
		74HCT									V _{CC} (V)	OTHER	
		+25			-40 to +85		-40 to +125		V _{CC} (V)				OTHER
		min.	typ.	max.	min.	max.	min.	max.					
t _{PLH}	propagation delay $\overline{nA_0}$, nA_1 to nQ		35	60		75		90	ns	4.5	Fig.8		
t _{PHL}	propagation delay $\overline{nA_0}$, nA_1 to \overline{nQ}		35	60		75		90	ns	4.5	Fig.8		
t _{PHL}	propagation delay nR_D to nQ		35	60		75		90	ns	4.5	Fig.8		
t _{PLH}	propagation delay nR_D to \overline{nQ}		35	60		75		90	ns	4.5	Fig.8		
t _{THL} / t _{TLH}	output transition time		7	15		19		21	ns	4.5	Fig.8		
t _w	$\overline{nA_0}$ pulse width LOW	20	11		25		30		ns	4.5	Fig.8		
t _w	nA_1 pulse width HIGH	16	5		20		24		ns	4.5	Fig.8		
t _w	$\overline{nR_D}$ pulse width LOW	20	11		25		30		ns	4.5	Fig.8		
t _w	nQ, \overline{nQ} pulse width HIGH or LOW	0.63	0.70	0.77	0.602	0.798	0.595	0.805	ms	5.0	Fig.8; R _t = 10 k Ω ; C _t = 0.1 μ F		
t _{rem}	removal time $\overline{R_D}$ to $\overline{nA_0}$, nA_1	7	2		9		11		ns	4.5	Fig.8		
t _{rt}	retrigger time $\overline{nA_0}$, nA_1	–	80+X		–		–		ns	4.5	Fig.8 X = C _{EXT} / (4.5 × V _{CC})		
R _{EXT}	external timing resistor	2		1000					k Ω	5.0			
C _{EXT}	external timing capacitor	no limits								pF	5.0		

Dual retriggerable precision monostable multivibrator

74HC/HCT4538

NON-STANDARD DC CHARACTERISTICS FOR 74HCT

Voltages are referenced to GND (ground = 0 V)

SYMBOL	PARAMETER	T _{amb} (°C)						UNIT	TEST CONDITIONS			
		74HCT							V _{CC} (V)	V _I (V)	OTHER	
		+25			-40 to +85		-40 to +125					
		min.	typ	max.	min.	max.	min.					max.
±I _l	input leakage current nRC _{EXT}			0.5		5.0		10.0	µA	5.5	2.0 or GND	V _{CC} or GND; note 1

Note

1. This measurement can only be carried out after a trigger pulse is applied.

AC WAVEFORMS

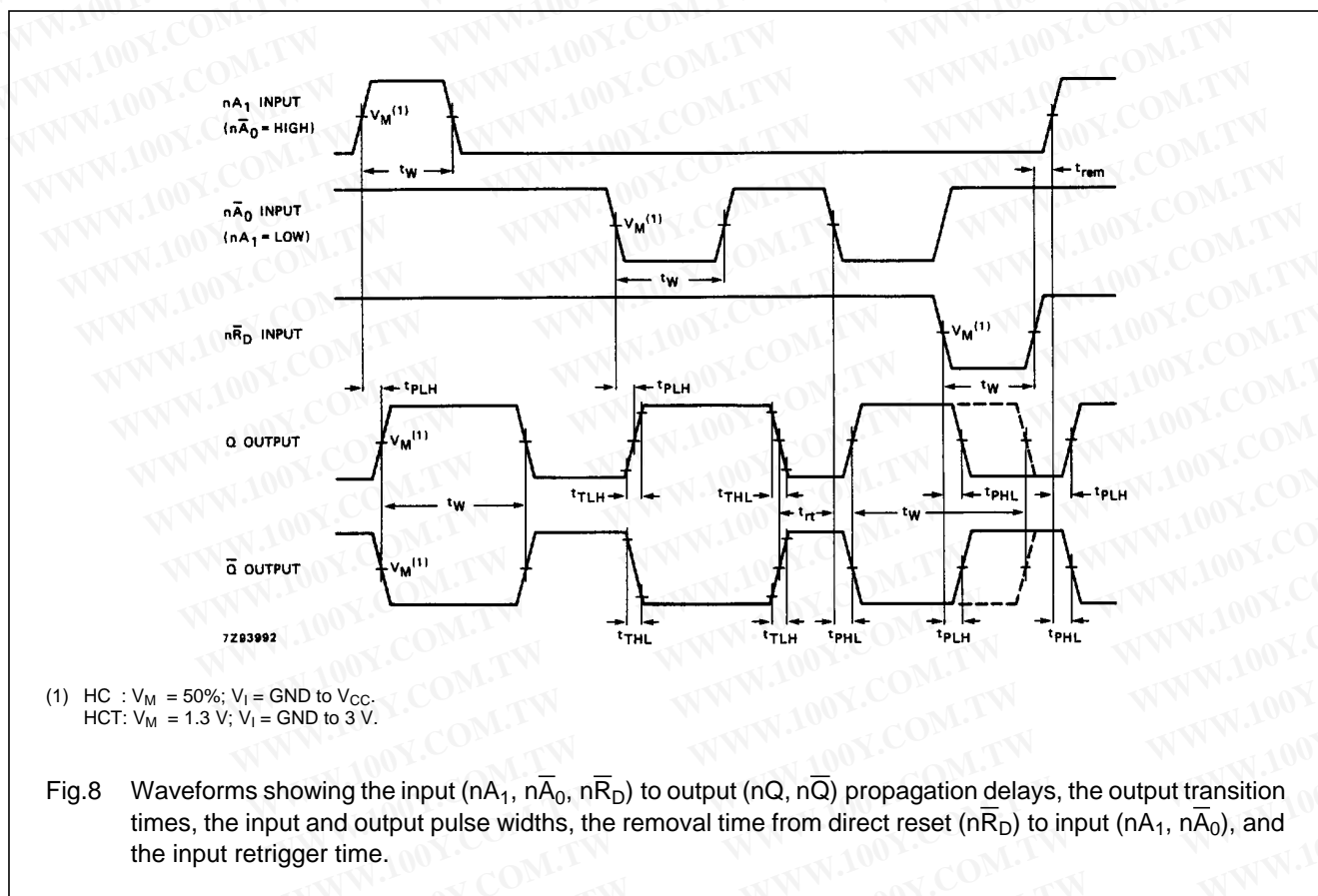

勝特力材料 886-3-5753170
 勝特力电子(上海) 86-21-54151736
 勝特力电子(深圳) 86-755-83298787
[Http://www.100y.com.tw](http://www.100y.com.tw)

Dual retriggerable precision monostable multivibrator

74HC/HCT4538

APPLICATION INFORMATION

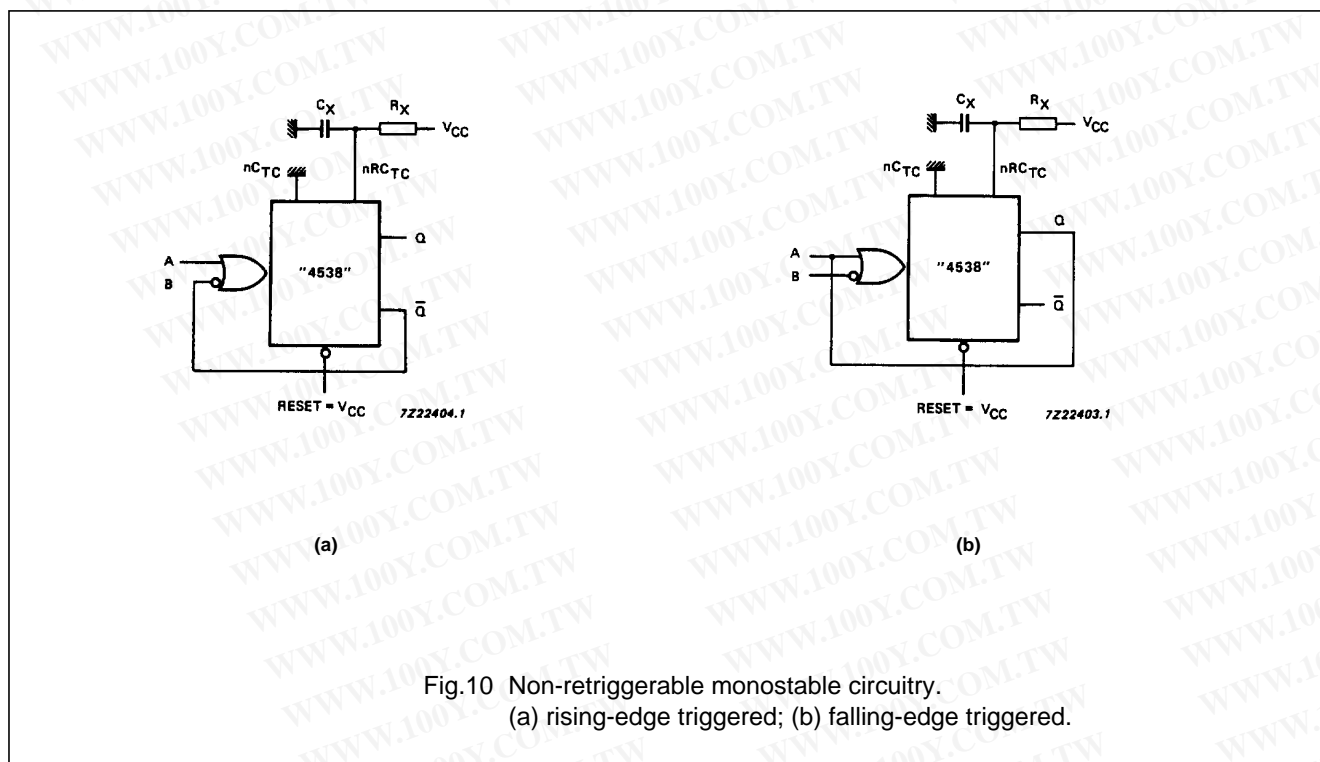
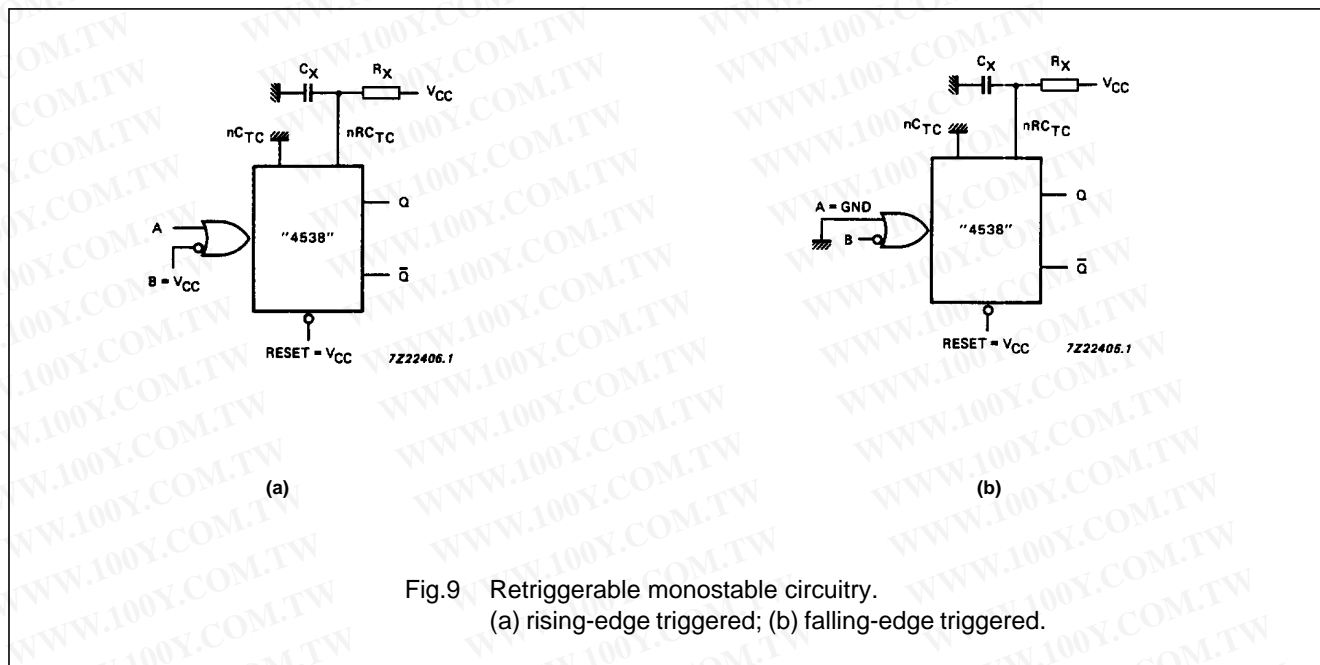

勝特力材料 886-3-5753170
 勝特力电子(上海) 86-21-54151736
 勝特力电子(深圳) 86-755-83298787
[Http://www.100y.com.tw](http://www.100y.com.tw)

Dual retriggerable precision monostable multivibrator

74HC/HCT4538

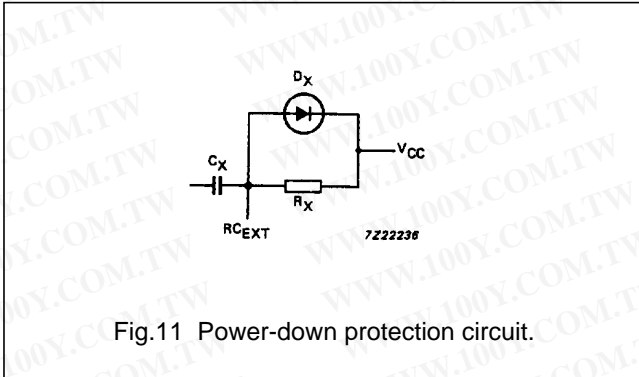

Fig.11 Power-down protection circuit.

Power-down considerations

A large capacitor (C_X) may cause problems when powering-down the monostable due to the energy stored in this capacitor. When a system containing this device is powered-down or a rapid decrease of V_{CC} to zero occurs, the monostable may sustain damage, due to the capacitor discharging through the input protection diodes. To avoid this possibility, use a damping diode (D_X) preferably a germanium or Schottky type diode able to withstand large current surges and connect as shown in Fig.11.

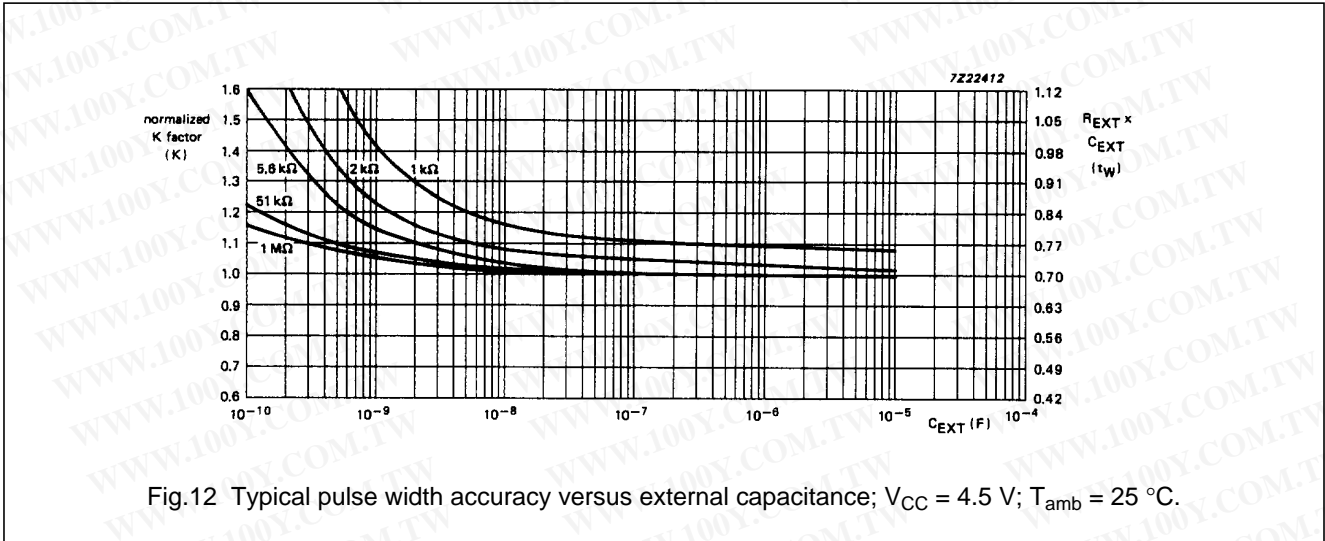

Fig.12 Typical pulse width accuracy versus external capacitance; $V_{CC} = 4.5 \text{ V}$; $T_{amb} = 25 \text{ }^\circ\text{C}$.

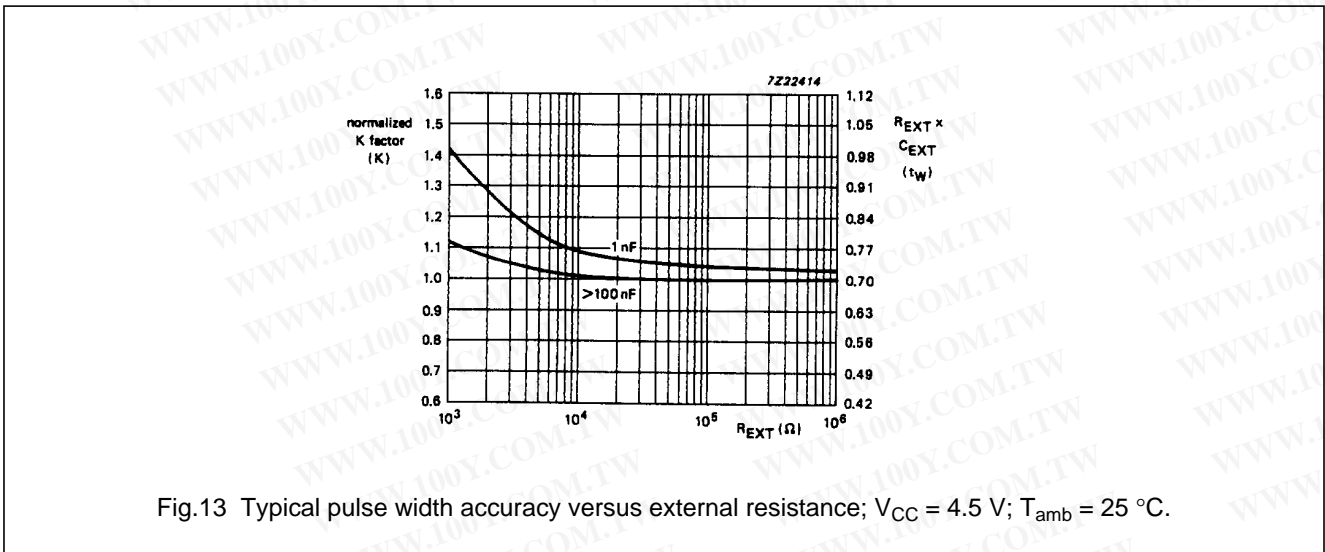
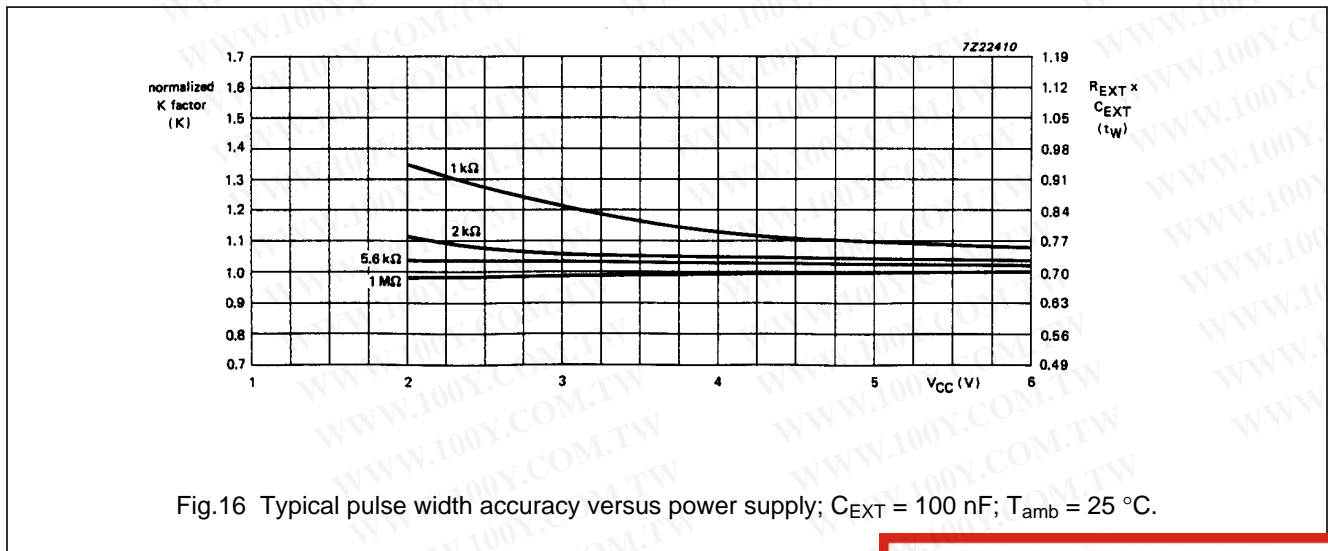
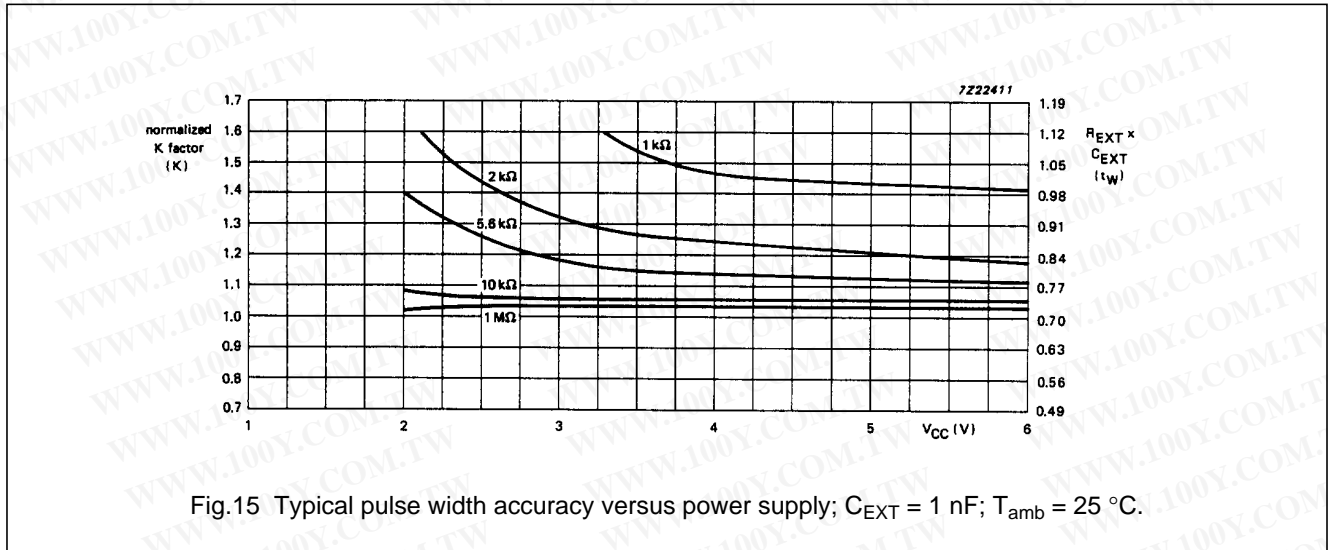
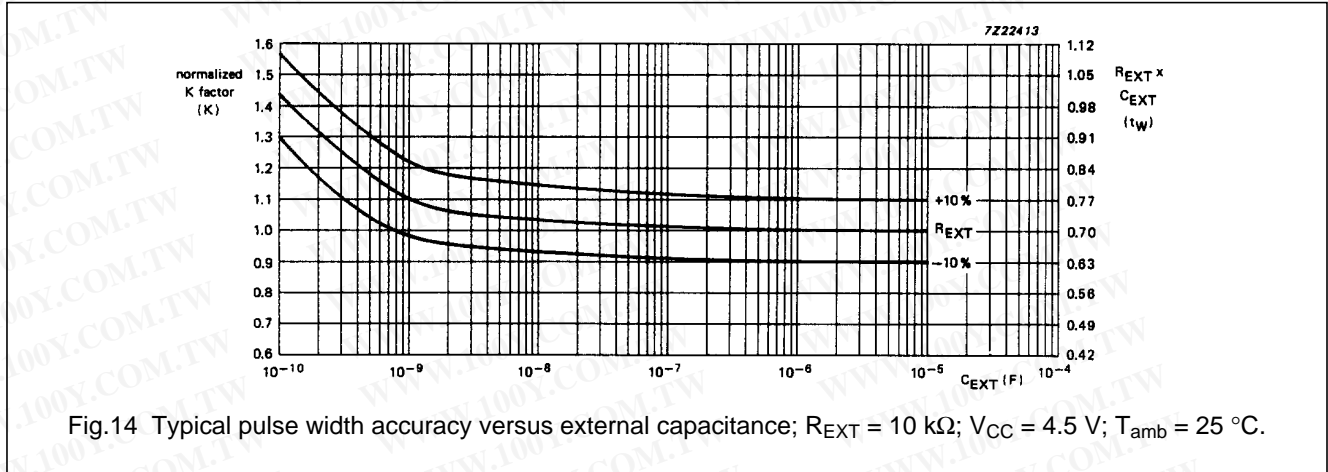

Fig.13 Typical pulse width accuracy versus external resistance; $V_{CC} = 4.5 \text{ V}$; $T_{amb} = 25 \text{ }^\circ\text{C}$.

Dual retriggerable precision monostable multivibrator

74HC/HCT4538



勝特力材料 886-3-5753170
 勝特力电子(上海) 86-21-54151736
 勝特力电子(深圳) 86-755-83298787
[Http://www.100y.com.tw](http://www.100y.com.tw)

Dual retriggerable precision monostable multivibrator

74HC/HCT4538

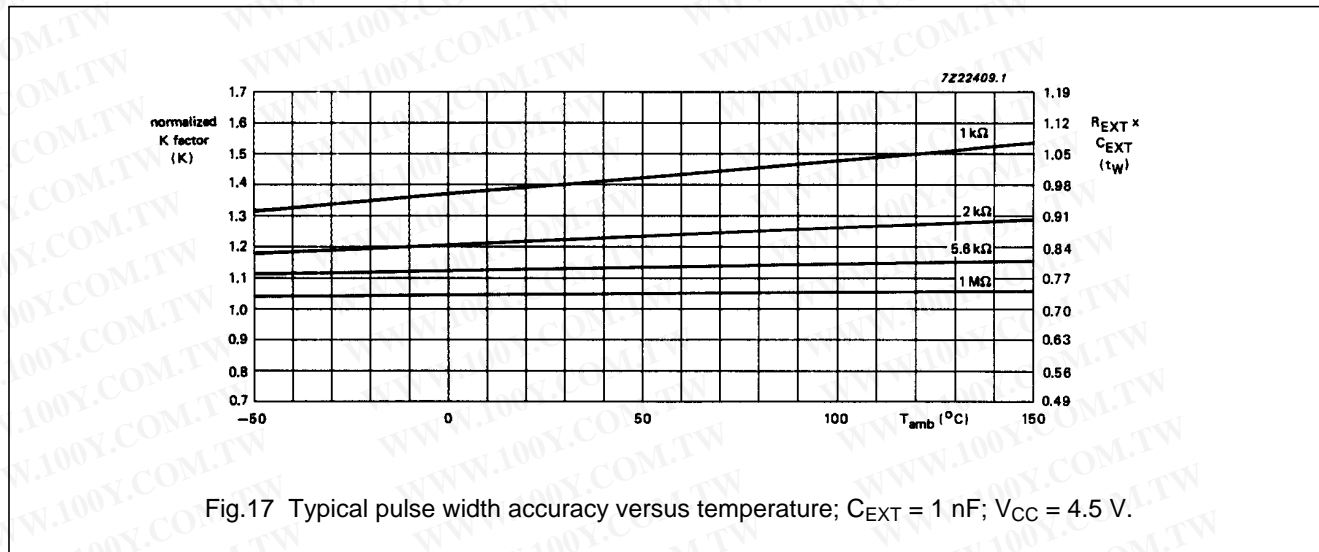

Fig.17 Typical pulse width accuracy versus temperature; $C_{EXT} = 1 \text{ nF}$; $V_{CC} = 4.5 \text{ V}$.

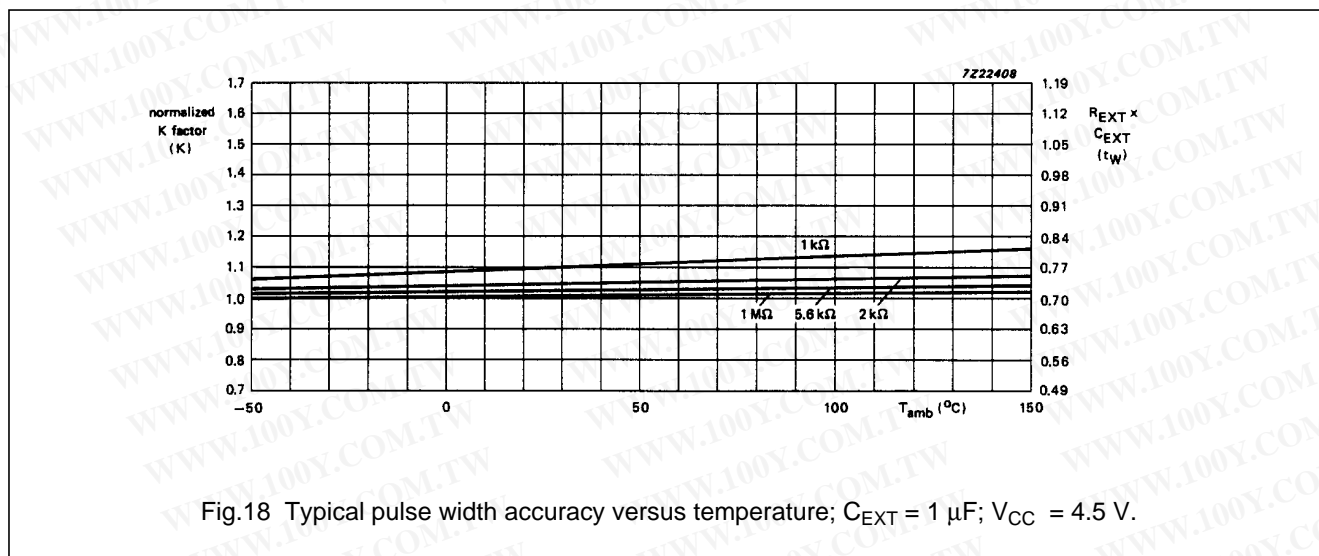

Fig.18 Typical pulse width accuracy versus temperature; $C_{EXT} = 1 \text{ }\mu\text{F}$; $V_{CC} = 4.5 \text{ V}$.

PACKAGE OUTLINES

See "74HC/HCT/HCU/HCMOS Logic Package Outlines".

勝特力材料 886-3-5753170
 勝特力电子(上海) 86-21-54151736
 勝特力电子(深圳) 86-755-83298787
[Http://www.100y.com.tw](http://www.100y.com.tw)