

## 54F/74F521 8-Bit Identity Comparator

### General Description

The '521 is an expandable 8-bit comparator. It compares two words of up to eight bits each and provides a LOW output when the two words match bit for bit. The expansion input  $\bar{I}_{A=B}$  also serves as an active LOW enable input.

### Features

- Compares two 8-bit words in 6.5 ns typ
- Expandable to any word length
- 20-pin package

Commercial	Military	Package Number	Package Description
74F521PC		N20A	20-Lead (0.300" Wide) Molded Dual-In-Line
	54F521DM (Note 2)	J20A	20-Lead Ceramic Dual-In-Line
74F521SC (Note 1)		M20B	20-Lead (0.300" Wide) Molded Small Outline, JEDEC
74F521SJ (Note 1)		M20D	20-Lead (0.300" Wide) Molded Small Outline, EIAJ
74F521MSA (Note 1)		MSA20	20-Lead Molded Shrink Small Outline, EIAJ type II

**Note 1:** Devices also available in 13" reel. Use suffix = SCX, SJX and MSAX.

**Note 2:** Military grade device with environmental and burn-in processing. Use suffix = DMOB.

### Logic Symbols

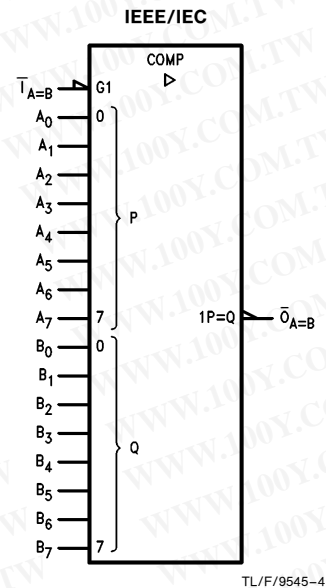
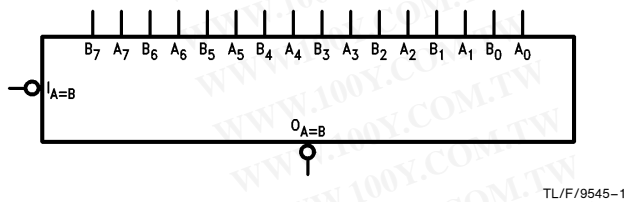

TRI-STATE® is a registered trademark of National Semiconductor Corporation.

## Unit Loading/Fan Out

Pin Names	Description	54F/74F	
		U.L. HIGH/LOW	Input $I_{IH}/I_{IL}$ Output $I_{OH}/I_{OL}$
A <sub>0</sub> -A <sub>7</sub>	Word A Inputs	1.0/1.0	20 $\mu$ A/ -0.6 mA
B <sub>0</sub> -B <sub>7</sub>	Word B Inputs	1.0/1.0	20 $\mu$ A/ -0.6 mA
$\bar{I}_A=B$	Expansion or Enable Input (Active LOW)	1.0/1.0	20 $\mu$ A/ -0.6 mA
$\bar{O}_A=B$	Identity Output (Active LOW)	50/33.3	-1 mA/20 mA

## Truth Table

Inputs		Output
$\bar{I}_A=B$	A, B	$\bar{O}_A=B$
L	A = B*	L
L	A $\neq$ B	H
H	A = B*	H
H	A $\neq$ B	H

H = HIGH Voltage Level  
L = LOW Voltage Level  
\*A<sub>0</sub> = B<sub>0</sub>, A<sub>1</sub> = B<sub>1</sub>, A<sub>2</sub> = B<sub>2</sub>, etc.

## Connection Diagrams

Pin Assignment for DIP, SOIC, SSOP and Flatpak

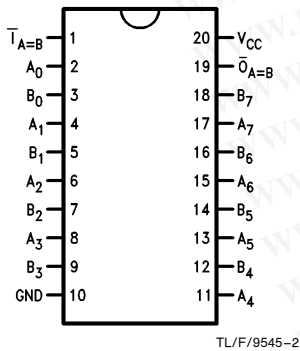

Pin Assignment for LCC

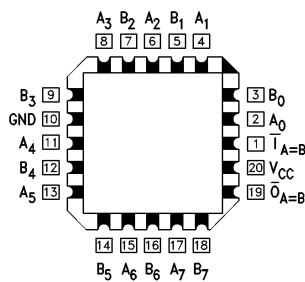

## Logic Diagram

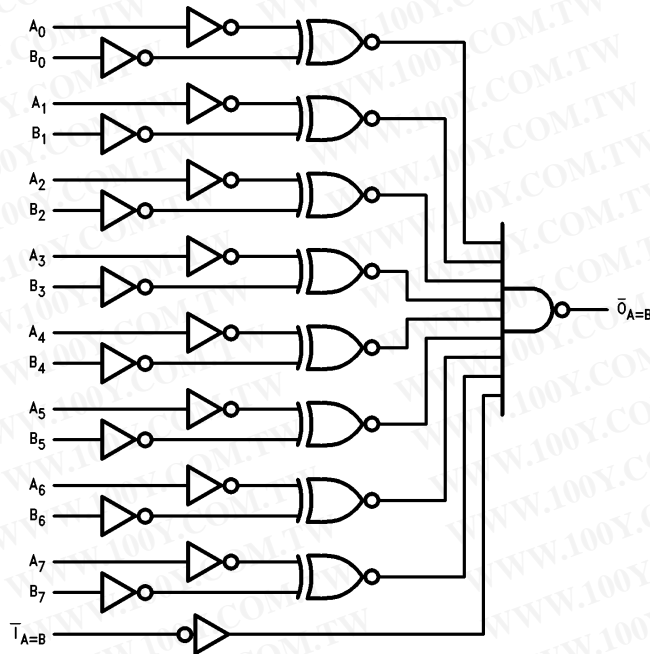

Please note that this diagram is provided only for the understanding of logic operations and should not be used to estimate propagation delays.

勝特力材料 886-3-5753170  
 勝特力电子(上海) 86-21-54151736  
 勝特力电子(深圳) 86-755-83298787  
[Http://www.100y.com.tw](http://www.100y.com.tw)

## Absolute Maximum Ratings (Note 1)

If Military/Aerospace specified devices are required, please contact the National Semiconductor Sales Office/Distributors for availability and specifications.

Storage Temperature	-65°C to +150°C
Ambient Temperature under Bias	-55°C to +125°C
Junction Temperature under Bias	-55°C to +175°C
Plastic	-55°C to +150°C
V <sub>CC</sub> Pin Potential to Ground Pin	-0.5V to +7.0V
Input Voltage (Note 2)	-0.5V to +7.0V
Input Current (Note 2)	-30 mA to +5.0 mA
Voltage Applied to Output in HIGH State (with V <sub>CC</sub> = 0V)	
Standard Output	-0.5V to V <sub>CC</sub>
TRI-STATE® Output	-0.5V to +5.5V

Current Applied to Output in LOW State (Max) twice the rated I<sub>OL</sub> (mA)

**Note 1:** Absolute maximum ratings are values beyond which the device may be damaged or have its useful life impaired. Functional operation under these conditions is not implied.

**Note 2:** Either voltage limit or current limit is sufficient to protect inputs.

## Recommended Operating Conditions

Free Air Ambient Temperature	
Military	-55°C to +125°C
Commercial	0°C to +70°C
Supply Voltage	
Military	+4.5V to +5.5V
Commercial	+4.5V to +5.5V

## DC Electrical Characteristics

Symbol	Parameter	54F/74F			Units	V <sub>CC</sub>	Conditions	
		Min	Typ	Max				
V <sub>IH</sub>	Input HIGH Voltage	2.0			V		Recognized as a HIGH Signal	
V <sub>IL</sub>	Input LOW Voltage			0.8	V		Recognized as a LOW Signal	
V <sub>CD</sub>	Input Clamp Diode Voltage			-1.2	V	Min	I <sub>IN</sub> = -18 mA	
V <sub>OH</sub>	Output HIGH Voltage	54F 10% V <sub>CC</sub>	2.5		V	Min	I <sub>OH</sub> = -1 mA I <sub>OH</sub> = -1 mA I <sub>OH</sub> = -1 mA	
		74F 10% V <sub>CC</sub>	2.5					
		74F 5% V <sub>CC</sub>	2.7					
V <sub>OL</sub>	Output LOW Voltage	54F 10% V <sub>CC</sub>		0.5	V	Min	I <sub>OL</sub> = 20 mA I <sub>OL</sub> = 20 mA	
		74F 10% V <sub>CC</sub>		0.5				
I <sub>IH</sub>	Input HIGH Current	54F		20.0	μA	Max	V <sub>IN</sub> = 2.7V	
		74F		5.0				
I <sub>BVI</sub>	Input HIGH Current Breakdown Test	54F		100	μA	Max	V <sub>IN</sub> = 7.0V	
		74F		7.0				
I <sub>CEX</sub>	Output HIGH Leakage Current	54F		250	μA	Max	V <sub>OUT</sub> = V <sub>CC</sub>	
		74F		50				
V <sub>ID</sub>	Input Leakage Test	74F	4.75		V	0.0	I <sub>ID</sub> = 1.9 μA All Other Pins Grounded	
I <sub>OD</sub>	Output Leakage Circuit Current	74F		3.75	μA	0.0	V <sub>IOD</sub> = 150 mV All Other Pins Grounded	
I <sub>IL</sub>	Input LOW Current			-0.6	mA	Max	V <sub>IN</sub> = 0.5V	
I <sub>OS</sub>	Output Short-Circuit Current			-60	-150	mA	Max	V <sub>OUT</sub> = 0V
I <sub>CCH</sub>	Power Supply Current		21	32	mA	Max	V <sub>O</sub> = HIGH	

勝特力材料 886-3-5753170  
 勝特力电子(上海) 86-21-54151736  
 勝特力电子(深圳) 86-755-83298787  
[Http://www.100y.com.tw](http://www.100y.com.tw)

## AC Electrical Characteristics

Symbol	Parameter	74F			54F		74F		Units
		T <sub>A</sub> = +25°C V <sub>CC</sub> = +5.0V C <sub>L</sub> = 50 pF			T <sub>A</sub> , V <sub>CC</sub> = Mil C <sub>L</sub> = 50 pF		T <sub>A</sub> , V <sub>CC</sub> = Com C <sub>L</sub> = 50 pF		
		Min	Typ	Max	Min	Max	Min	Max	
t <sub>PLH</sub>	Propagation Delay	3.0	7.0	10.0	3.0	14.0	3.0	11.0	ns
t <sub>PHL</sub>	A <sub>n</sub> or B <sub>n</sub> to $\overline{O}_{A=B}$	4.5	7.0	10.0	4.0	15.0	4.0	11.0	
t <sub>PLH</sub>	Propagation Delay	3.0	5.0	6.5	3.0	8.5	3.0	7.5	ns
t <sub>PHL</sub>	$\overline{I}_{A=B}$ to $\overline{O}_{A=B}$	3.5	6.5	9.0	3.5	13.5	3.5	10.0	

## Applications

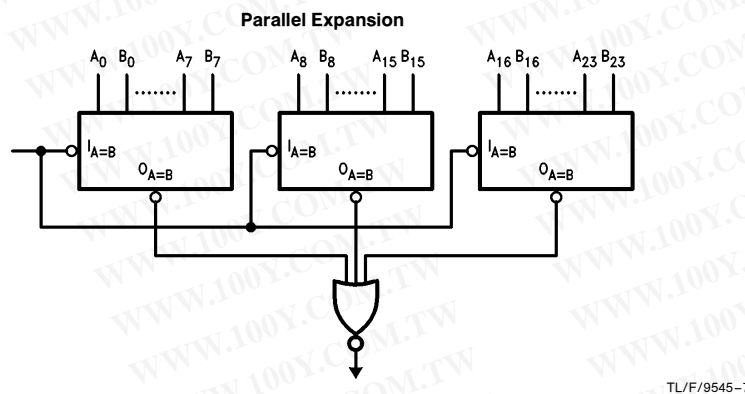
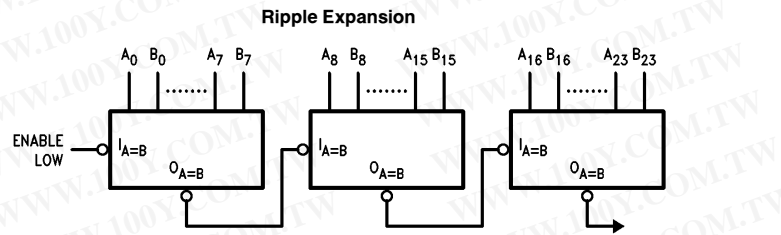

## Ordering Information

The device number is used to form part of a simplified purchasing code where the package type and temperature range are defined as follows:

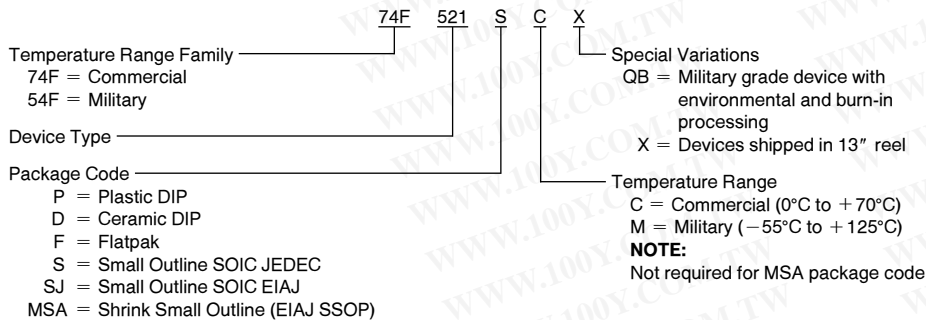

**Physical Dimensions** inches (millimeters)

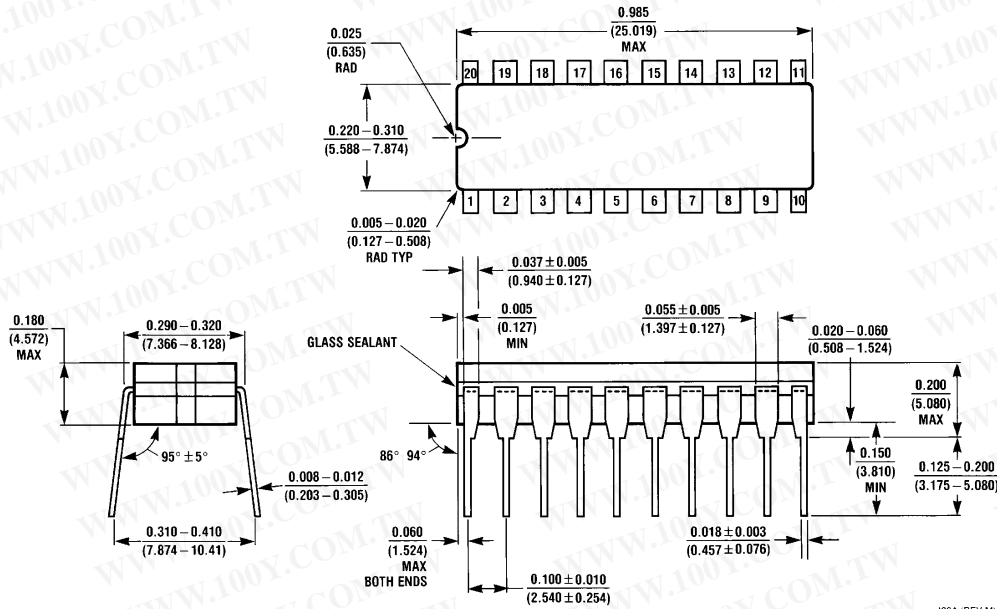

**20-Lead Ceramic Dual-In-Line Package (D)  
NS Package Number J20A**

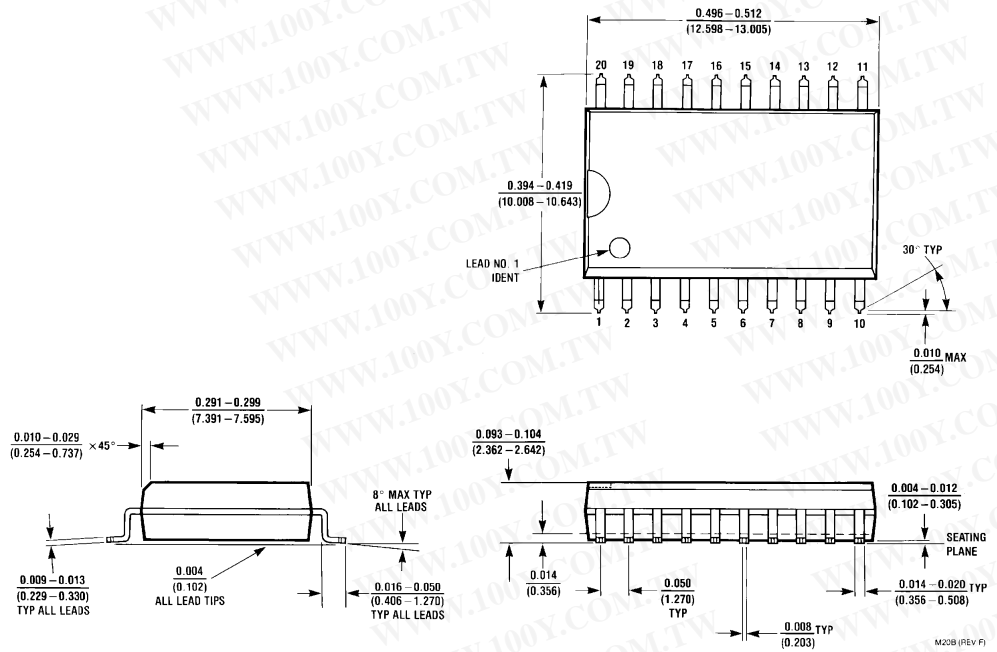

**20-Lead (0.300" Wide) Molded Small Outline Package, JEDEC (S)  
NS Package Number M20B**

**Physical Dimensions** inches (millimeters) (Continued)

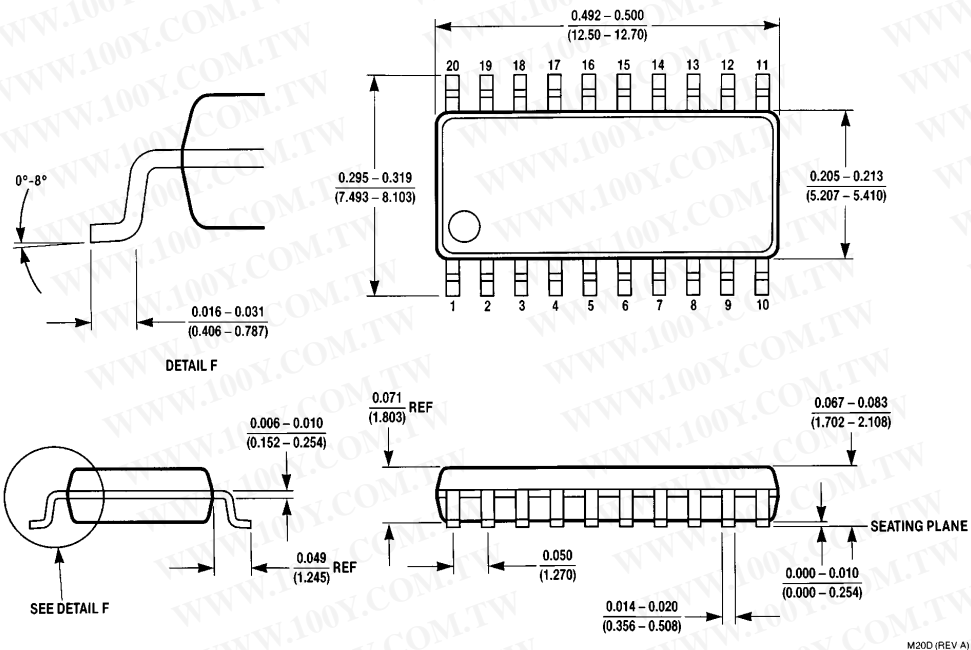

**20-Lead (0.300" Wide) Molded Small Outline Package, EIAJ (SJ)  
NS Package Number M20D**

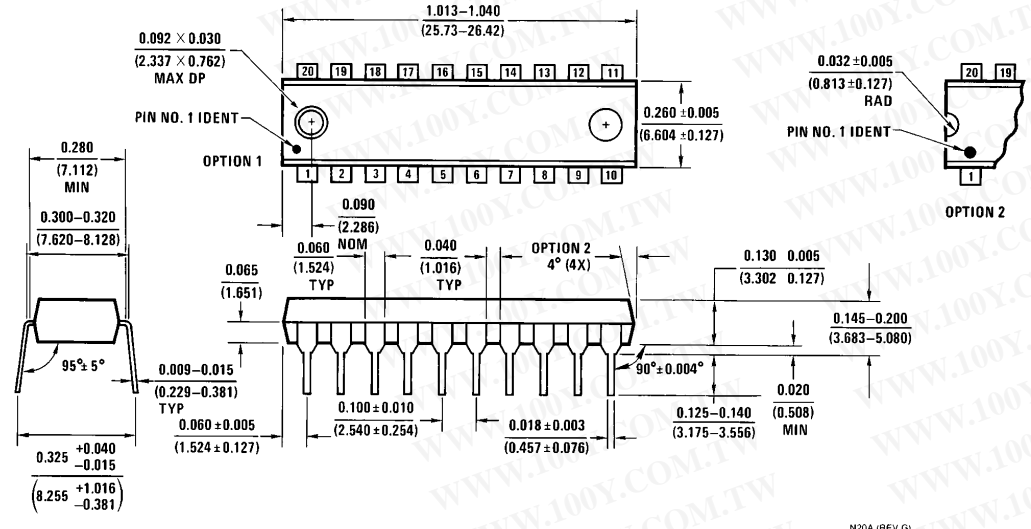

**20-Lead (0.300" Wide) Molded Dual-In-Line Package (P)  
NS Package Number N20A**

**Physical Dimensions** inches (millimeters) (Continued)

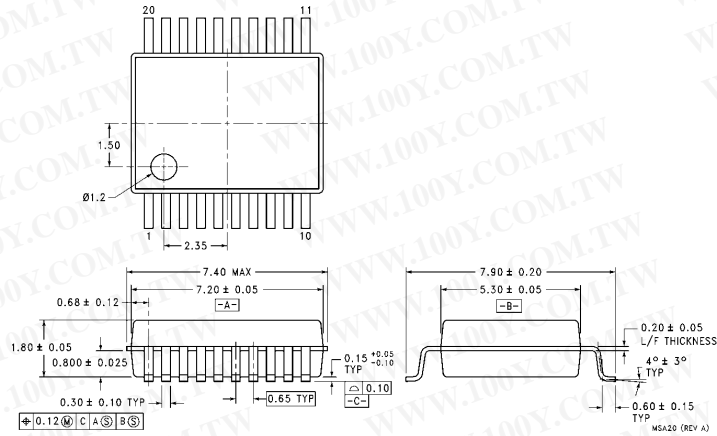

**20-Lead (0.300" Wide) Molded Shrink Outline Package, EIAJ, Type II (MSA)**  
**NS Package Number MSA20**

勝特力材料 886-3-5753170  
 勝特力电子(上海) 86-21-54151736  
 勝特力电子(深圳) 86-755-83298787  
[Http://www.100y.com.tw](http://www.100y.com.tw)

**Physical Dimensions** inches (millimeters) (Continued)

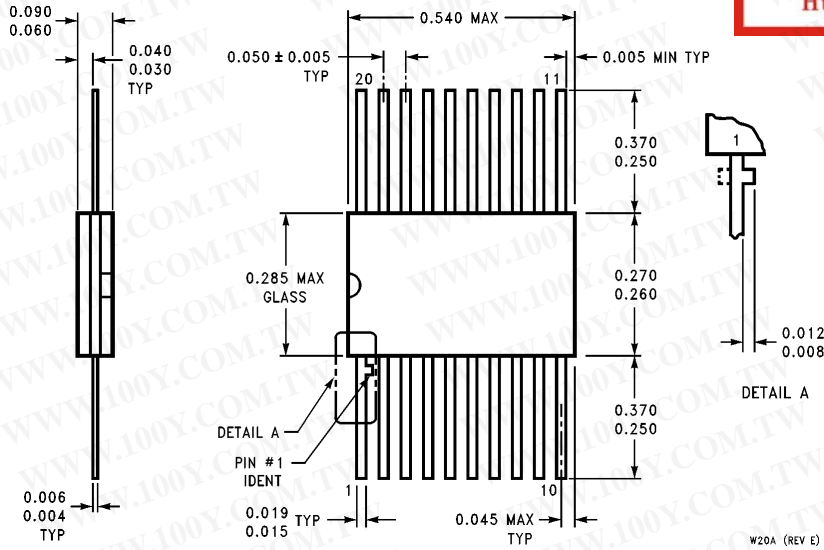

**20-Lead Ceramic Flatpak (F)  
 NS Package Number W20A**

**LIFE SUPPORT POLICY**

NATIONAL'S PRODUCTS ARE NOT AUTHORIZED FOR USE AS CRITICAL COMPONENTS IN LIFE SUPPORT DEVICES OR SYSTEMS WITHOUT THE EXPRESS WRITTEN APPROVAL OF THE PRESIDENT OF NATIONAL SEMICONDUCTOR CORPORATION. As used herein:

1. Life support devices or systems are devices or systems which, (a) are intended for surgical implant into the body, or (b) support or sustain life, and whose failure to perform, when properly used in accordance with instructions for use provided in the labeling, can be reasonably expected to result in a significant injury to the user.
2. A critical component is any component of a life support device or system whose failure to perform can be reasonably expected to cause the failure of the life support device or system, or to affect its safety or effectiveness.

 <p><b>National Semiconductor Corporation</b>                  2900 Semiconductor Drive                  P.O. Box 58090                  Santa Clara, CA 95052-8090                  Tel: (800) 272-9959                  TWX: (910) 339-9240</p>	<p><b>National Semiconductor GmbH</b>                  Livny-Gargan-Str. 10                  D-82256 Fürstenfeldbruck                  Germany                  Tel: (81-41) 35-0                  Telex: 527849                  Fax: (81-41) 35-1</p>	<p><b>National Semiconductor Japan Ltd.</b>                  Sumitomo Chemical Engineering Center                  Bldg. 7F                  1-7-1, Nakase, Mihama-Ku                  Chiba-City,                  Ciba Prefecture 261                  Tel: (043) 299-2300                  Fax: (043) 299-2500</p>	<p><b>National Semiconductor Hong Kong Ltd.</b>                  13th Floor, Straight Block,                  Ocean Centre, 5 Canton Rd.                  Tsimshatsui, Kowloon                  Hong Kong                  Tel: (852) 2737-1600                  Fax: (852) 2736-9960</p>	<p><b>National Semicondutores Do Brazil Ltda.</b>                  Rue Deputado Lacorda Franco                  120-3A                  Sao Paulo-SP                  Brazil 05418-000                  Tel: (55-11) 212-5066                  Telex: 391-1131931 NSBR BR                  Fax: (55-11) 212-1181</p>	<p><b>National Semiconductor (Australia) Pty. Ltd.</b>                  Building 16                  Business Park Drive                  Monash Business Park                  Nottingham, Melbourne                  Victoria 3168 Australia                  Tel: (3) 558-9999                  Fax: (3) 558-9998</p>
--	---	---	---	--	--

National does not assume any responsibility for use of any circuitry described, no circuit patent licenses are implied and National reserves the right at any time without notice to change said circuitry and specifications.