



# 74ACT161

## SYNCHRONOUS PRESETTABLE 4-BIT COUNTER

- HIGH SPEED:**  
 $f_{MAX} = 125 \text{ MHz (TYP.) at } V_{CC} = 5\text{V}$
- LOW POWER DISSIPATION:**  
 $I_{CC} = 8 \mu\text{A (MAX.) at } T_A = 25 \text{ }^\circ\text{C}$
- COMPATIBLE WITH TTL OUTPUTS**  
 $V_{IH} = 2\text{V (MIN)}, V_{IL} = 0.8\text{V (MAX)}$
- 50Ω TRANSMISSION LINE DRIVING CAPABILITY**
- SYMMETRICAL OUTPUT IMPEDANCE:**  
 $|I_{OH}| = I_{OL} = 24 \text{ mA (MIN)}$
- BALANCED PROPAGATION DELAYS:**  
 $t_{PLH} \cong t_{PHL}$
- OPERATING VOLTAGE RANGE:**  
 $V_{CC} \text{ (OPR)} = 4.5\text{V to } 5.5\text{V}$
- PIN AND FUNCTION COMPATIBLE WITH 74 SERIES 161**
- IMPROVED LATCH-UP IMMUNITY**

### DESCRIPTION

The ACT161 is a high-speed CMOS SYNCHRONOUS PRESETTABLE COUNTER fabricated with sub-micron silicon gate and double-layer metal wiring C<sup>2</sup>MOS technology. It is ideal for low power applications maintaining high speed operation similar to equivalent Bipolar Schottky TTL. It is a 4 bit binary counter with Asynchronous Clear.

The circuit have four fundamental modes of operation, in order of preference: synchronous reset, parallel load, count-up and hold. Four control inputs, Master Reset (CLEAR), Parallel

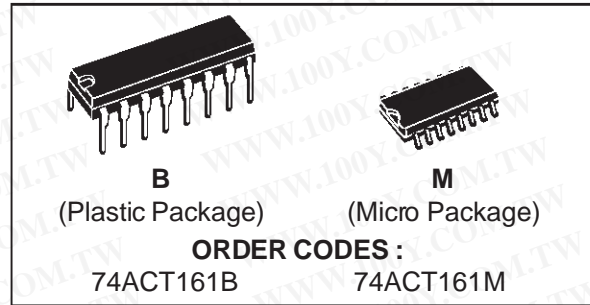

Enable Input (LOAD), Count Enable Input (PE) and Count Enable Carry Input (TE), determine the mode of operation as shown in the Truth Table. A LOW signal on CLEAR overrides counting and parallel loading and sets all outputs on LOW state. A LOW signal on LOAD overrides counting and allows information on Parallel Data Qn inputs to be loaded into the flip-flops on the next rising edge of CLOCK. With LOAD and CLEAR, PE and TE permit counting when both are HIGH. Conversely, a LOW signal on either PE and TE inhibits counting.

The device is designed to interface directly High Speed CMOS systems with TTL, NMOS and CMOS output voltage levels.

All inputs and outputs are equipped with protection circuits against static discharge, giving them 2KV ESD immunity and transient excess voltage.

### PIN CONNECTION AND IEC LOGIC SYMBOLS

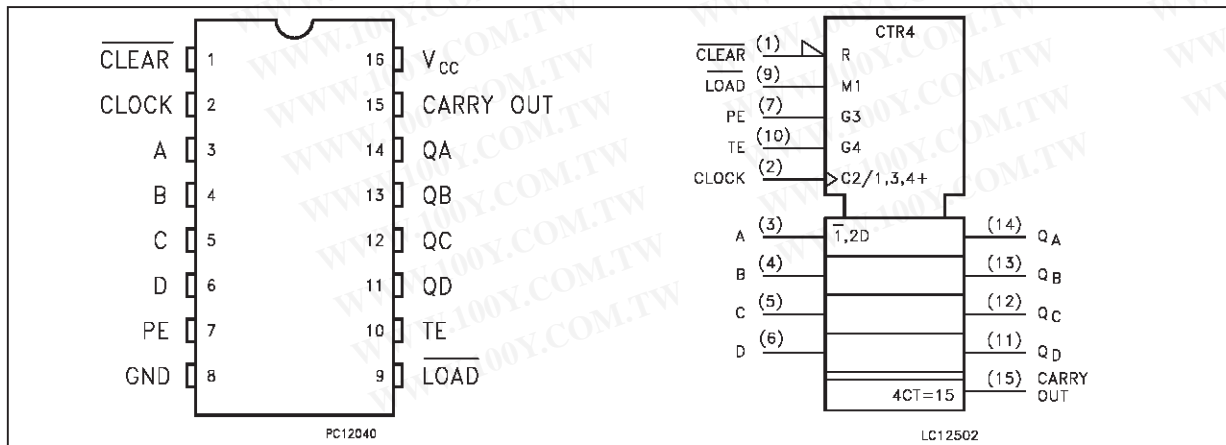

74ACT161

INPUT AND OUTPUT EQUIVALENT CIRCUIT

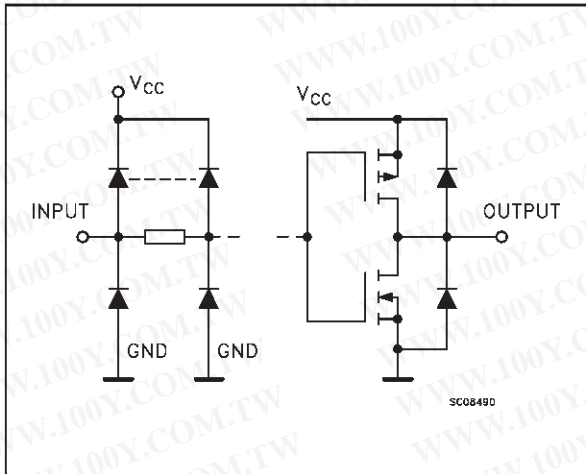

PIN DESCRIPTION

PIN No	SYMBOL	NAME AND FUNCTION
1	$\overline{\text{CLEAR}}$	Master Reset
2	CLOCK	Clock Input (LOW-to-HIGH, Edge- Triggered)
3, 4, 5, 6	A, B, C, D	Data Inputs
7	PE	Count Enable Input
10	$\overline{\text{TE}}$	Count Enable Carry Input
9	$\overline{\text{LOAD}}$	Parallel Enable Input
14, 13, 12, 11	QA to QD	Flip-Flop Output
15	CARRY OUT	Terminal Count Output
8	GND	Ground (0V)
16	V <sub>CC</sub>	Positive Supply Voltage

TRUTH TABLE

INPUTS					OUTPUTS				FUNCTION
$\overline{\text{CLEAR}}$	$\overline{\text{LOAD}}$	PE	TE	CLOCK	QA	QB	QC	QD	
L	X	X	X	X	L	L	L	L	RESET TO "0"
H	L	X	X		A	B	C	D	PRESET DATA
H	H	X	L		NO CHANGE				NO COUNT
H	H	L	X		NO CHANGE				NO COUNT
H	H	H	H		COUNT UP				COUNT
H	X	X	X		NO CHANGE				NO COUNT

NOTE: X: Don't Care  
 A, B, C, D: Logic level of data input  
 $\text{CARRY} = \text{TE} \cdot \text{QA} \cdot \text{QB} \cdot \text{QC} \cdot \text{QD}$

LOGIC DIAGRAMS

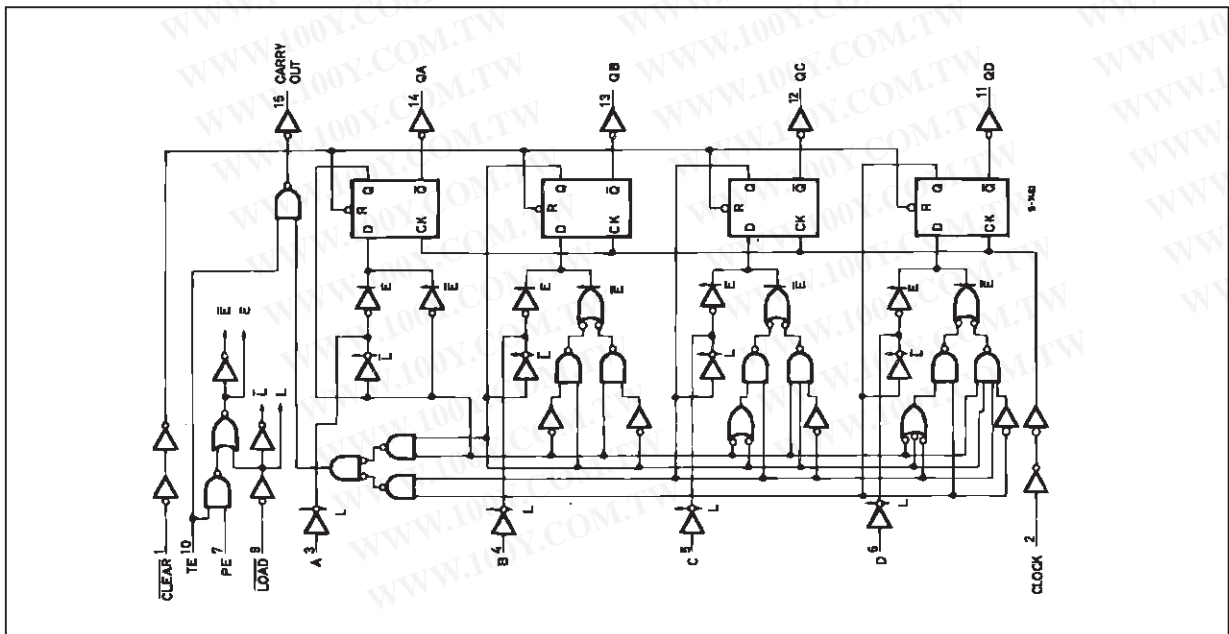

TIMING CHART

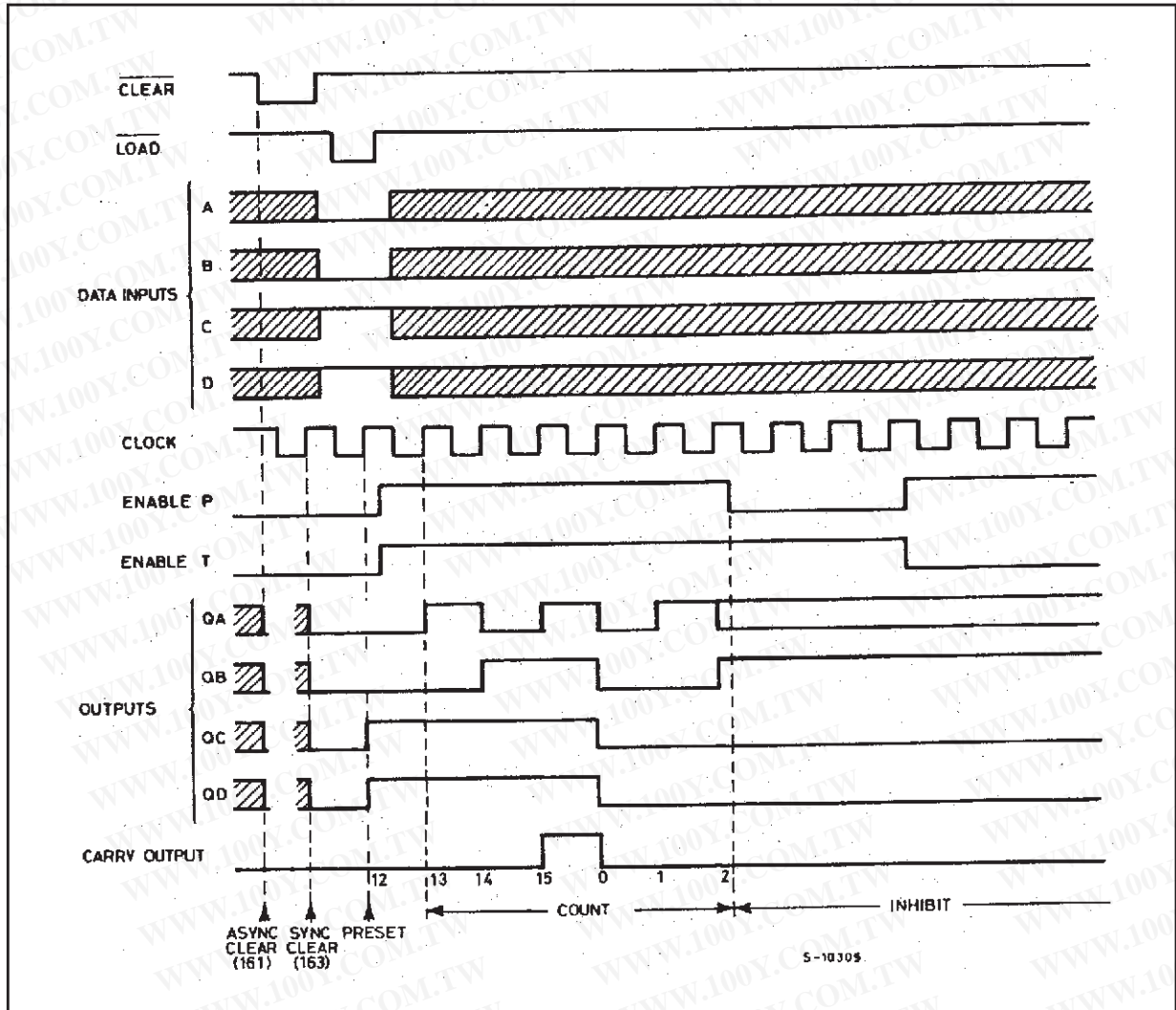

## 74ACT161

### ABSOLUTE MAXIMUM RATINGS

Symbol	Parameter	Value	Unit
V <sub>CC</sub>	Supply Voltage	-0.5 to +7	V
V <sub>I</sub>	DC Input Voltage	-0.5 to V <sub>CC</sub> + 0.5	V
V <sub>O</sub>	DC Output Voltage	-0.5 to V <sub>CC</sub> + 0.5	V
I <sub>IK</sub>	DC Input Diode Current	± 20	mA
I <sub>OK</sub>	DC Output Diode Current	± 20	mA
I <sub>O</sub>	DC Output Current	± 50	mA
I <sub>CC</sub> or I <sub>GND</sub>	DC V <sub>CC</sub> or Ground Current	± 300	mA
T <sub>stg</sub>	Storage Temperature	-65 to +150	°C
T <sub>L</sub>	Lead Temperature (10 sec)	300	°C

Absolute Maximum Ratings are those values beyond which damage to the device may occur. Functional operation under these condition is not implied.

### RECOMMENDED OPERATING CONDITIONS

Symbol	Parameter	Value	Unit
V <sub>CC</sub>	Supply Voltage	4.5 to 5.5	V
V <sub>I</sub>	Input Voltage	0 to V <sub>CC</sub>	V
V <sub>O</sub>	Output Voltage	0 to V <sub>CC</sub>	V
T <sub>op</sub>	Operating Temperature:	-40 to +85	°C
dt/dv	Input Rise and Fall Time V <sub>CC</sub> = 4.5 to 5.5V (note 1)	8	ns/V

1) V<sub>IN</sub> from 0.8V to 2.0V

### DC SPECIFICATIONS

Symbol	Parameter	Test Conditions		Value					Unit	
				V <sub>CC</sub> (V)	T <sub>A</sub> = 25 °C			-40 to 85 °C		
					Min.	Typ.	Max.	Min.		Max.
V <sub>IH</sub>	High Level Input Voltage	4.5	V <sub>O</sub> = 0.1 V or V <sub>CC</sub> - 0.1 V	2.0	1.5		2.0		V	
		5.5		2.0	1.5		2.0			
V <sub>IL</sub>	Low Level Input Voltage	4.5	V <sub>O</sub> = 0.1 V or V <sub>CC</sub> - 0.1 V		1.5	0.8		0.8	V	
		5.5			1.5	0.8		0.8		
V <sub>OH</sub>	High Level Output Voltage	4.5	V <sub>I</sub> (*) = V <sub>IH</sub> or V <sub>IL</sub>	I <sub>O</sub> = -50 μA	4.4	4.49		4.4	V	
		5.5			5.4	5.49		5.4		
		4.5		I <sub>O</sub> = -24 mA	3.86			3.76		
		5.5			4.86			4.76		
V <sub>OL</sub>	Low Level Output Voltage	4.5	V <sub>I</sub> (*) = V <sub>IH</sub> or V <sub>IL</sub>	I <sub>O</sub> = 50 μA	0.001	0.1		0.1	V	
		5.5			0.001	0.1		0.1		
		4.5		I <sub>O</sub> = 24 mA			0.36	0.44		
		5.5					0.36	0.44		
I <sub>I</sub>	Input Leakage Current	5.5	V <sub>I</sub> = V <sub>CC</sub> or GND			±0.1		±1	μA	
I <sub>CC(T)</sub>	Max I <sub>CC</sub> /Input	5.5	V <sub>I</sub> = V <sub>CC</sub> - 2.1 V		0.6			1.5	mA	
I <sub>CC</sub>	Quiescent Supply Current	5.5	V <sub>I</sub> = V <sub>CC</sub> or GND			4		40	μA	
I <sub>OLD</sub>	Dynamic Output Current (note 1, 2)	5.5	V <sub>OLD</sub> = 1.65 V max					75	mA	
I <sub>OHD</sub>			V <sub>OHD</sub> = 3.85 V min					-75	mA	

1) Maximum test duration 2ms, one output loaded at time

2) Incident wave switching is guaranteed on transmission lines with impedances as low as 50 Ω.

(\*) All outputs loaded.

**AC ELECTRICAL CHARACTERISTICS** ( $C_L = 50 \text{ pF}$ ,  $R_L = 500 \Omega$ , Input  $t_r = t_f = 3 \text{ ns}$ )

Symbol	Parameter	Test Condition	Value					Unit	
			V <sub>CC</sub> (V)	T <sub>A</sub> = 25 °C			-40 to 85 °C		
				Min.	Typ.	Max.	Min.		Max.
t <sub>PLH</sub> t <sub>PHL</sub>	Propagation Delay Time CK to Q	5.0 <sup>(*)</sup>	1.5	5.5	9.5		10.5	ns	
t <sub>PLH</sub> t <sub>PHL</sub>	Propagation Delay Time CK to CARRY OUT	5.0 <sup>(*)</sup>	1.5	7.0	11.0		12.0	ns	
t <sub>PLH</sub> t <sub>PHL</sub>	Propagation Delay Time TE to CARRY OUT	5.0 <sup>(*)</sup>	1.5	5.5	8.5		10.0	ns	
t <sub>PHL</sub>	Propagation Delay Time CLEAR to CARRY OUT	5.0 <sup>(*)</sup>	1.5	6.0	10.0		11.0	ns	
t <sub>WL</sub>	CLR pulse Width, LOW	5.0 <sup>(*)</sup>		2.5	3.0		7.5	ns	
t <sub>w</sub>	CK pulse Width (LOAD) HIGH or LOW	5.0 <sup>(*)</sup>		2.0	3.0		3.5	ns	
t <sub>w</sub>	CK pulse Width (COUNT) HIGH or LOW	5.0 <sup>(*)</sup>		2.0	3.0		3.5	ns	
t <sub>s</sub>	Setup Time HIGH or LOW (INPUT to CK)	5.0 <sup>(*)</sup>		1.5	9.5		11.5	ns	
t <sub>h</sub>	Hold Time HIGH or LOW (INPUT to CK)	5.0 <sup>(*)</sup>		-0.5	0		1.0	ns	
t <sub>s</sub>	Setup Time HIGH or LOW (LOAD to CK)	5.0 <sup>(*)</sup>		2.0	8.5		9.5	ns	
t <sub>h</sub>	Hold Time HIGH or LOW (LOAD to CK)	5.0 <sup>(*)</sup>		-2.0	-0.5		0	ns	
t <sub>s</sub>	Setup Time HIGH or LOW (PE or TE to CK)	5.0 <sup>(*)</sup>		1.5	5.5		6.5	ns	
t <sub>h</sub>	Hold Time HIGH or LOW (PE or TE to CK)	5.0 <sup>(*)</sup>		-2.0	0		0.5	ns	
t <sub>REM</sub>	Recovery Time CLR to Q	5.0 <sup>(*)</sup>		-0.5	0.5		1.0	ns	
f <sub>MAX</sub>	Maximum Clock Frequency	5.0 <sup>(*)</sup>	115	125		100		MHz	

(\*) Voltage range is 5V ± 0.5V

**CAPACITIVE CHARACTERISTICS**

Symbol	Parameter	Test Conditions	Value					Unit	
			V <sub>CC</sub> (V)	T <sub>A</sub> = 25 °C			-40 to 85 °C		
				Min.	Typ.	Max.	Min.		Max.
C <sub>IN</sub>	Input Capacitance		5.0		4.5			pF	
C <sub>PD</sub>	Power Dissipation Capacitance (note 1)	f <sub>IN</sub> = 10 MHz	5.0		45			pF	

1) C<sub>PD</sub> is defined as the value of the IC's internal equivalent capacitance which is calculated from the operating current consumption without load. (Refer to Test Circuit). Average operating current can be obtained by the following equation. I<sub>CC(opr)</sub> = C<sub>PD</sub> • V<sub>CC</sub> • f<sub>IN</sub> + I<sub>CC</sub>/n (per circuit)

74ACT161

TEST CIRCUIT

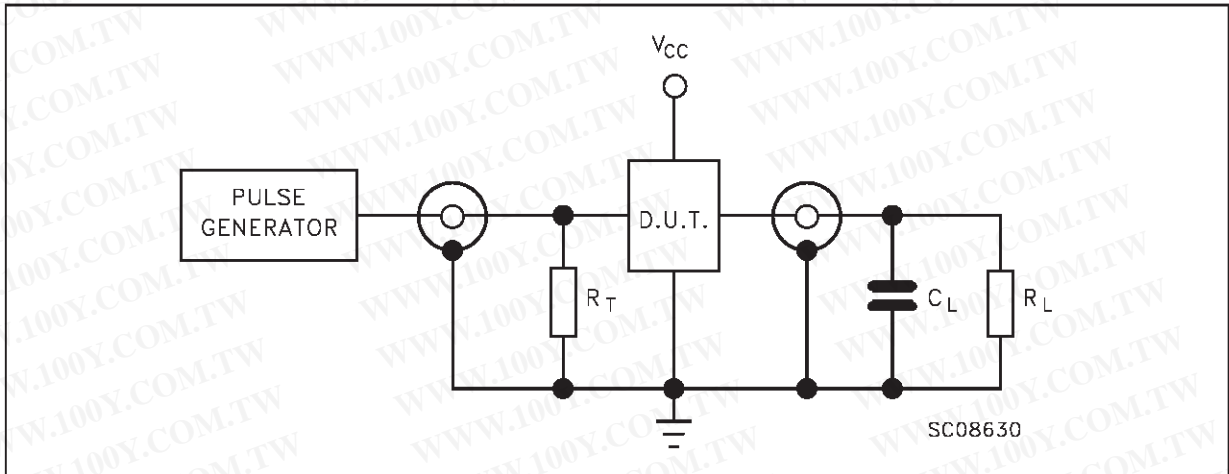

$C_L = 50 \text{ pF}$  or equivalent (includes jig and probe capacitance)  
 $R_L = R_T = 500\Omega$  or equivalent  
 $R_T = Z_{out}$  of pulse generator (typically  $50\Omega$ )

WAVEFORM 1: PROPAGATION DELAYS, COUNT MODE ( $f=1\text{MHz}$ ; 50% duty cycle)

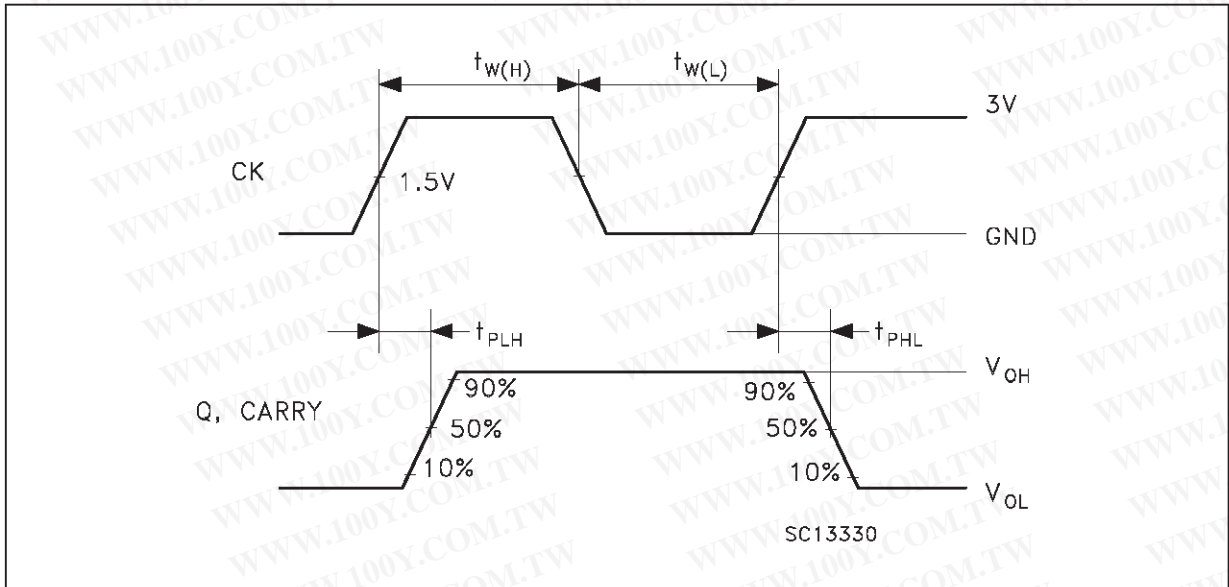

WAVEFORM 2: PROPAGATION DELAYS CLEAR MODE (f=1MHz; 50% duty cycle)

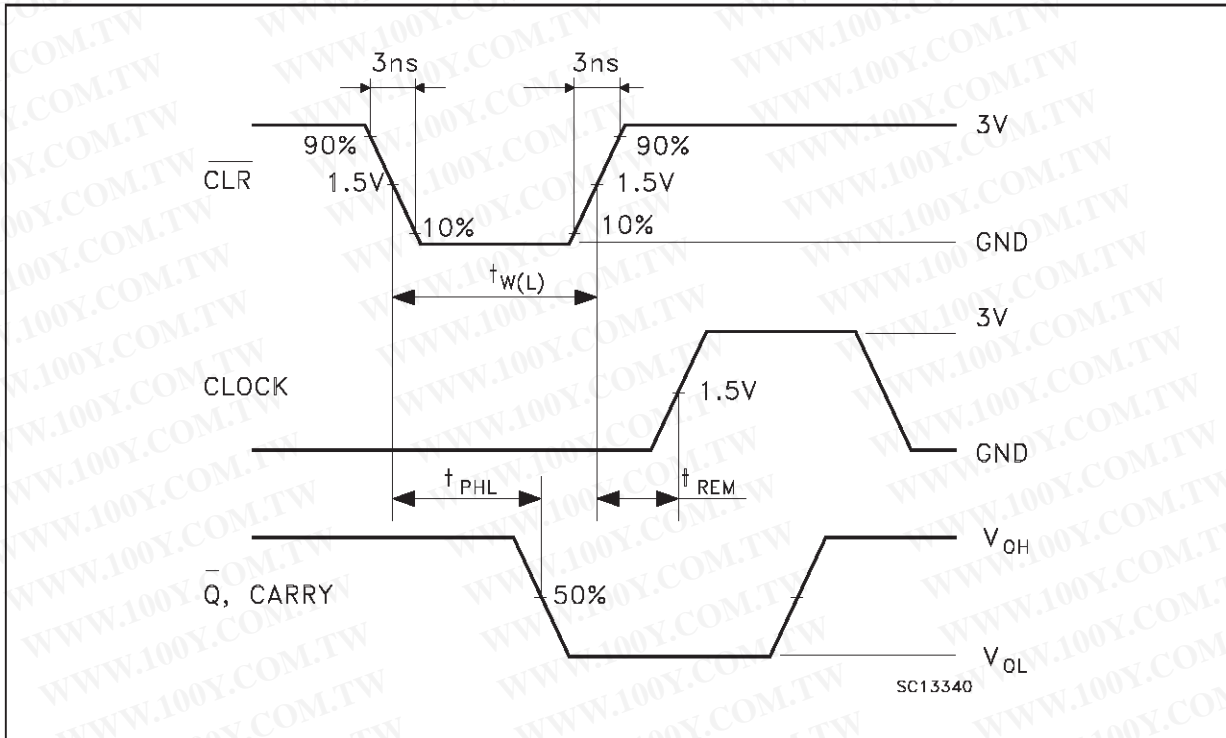

WAVEFORM 3: PROPAGATION DELAYS PRESET MODE (f=1MHz; 50% duty cycle)

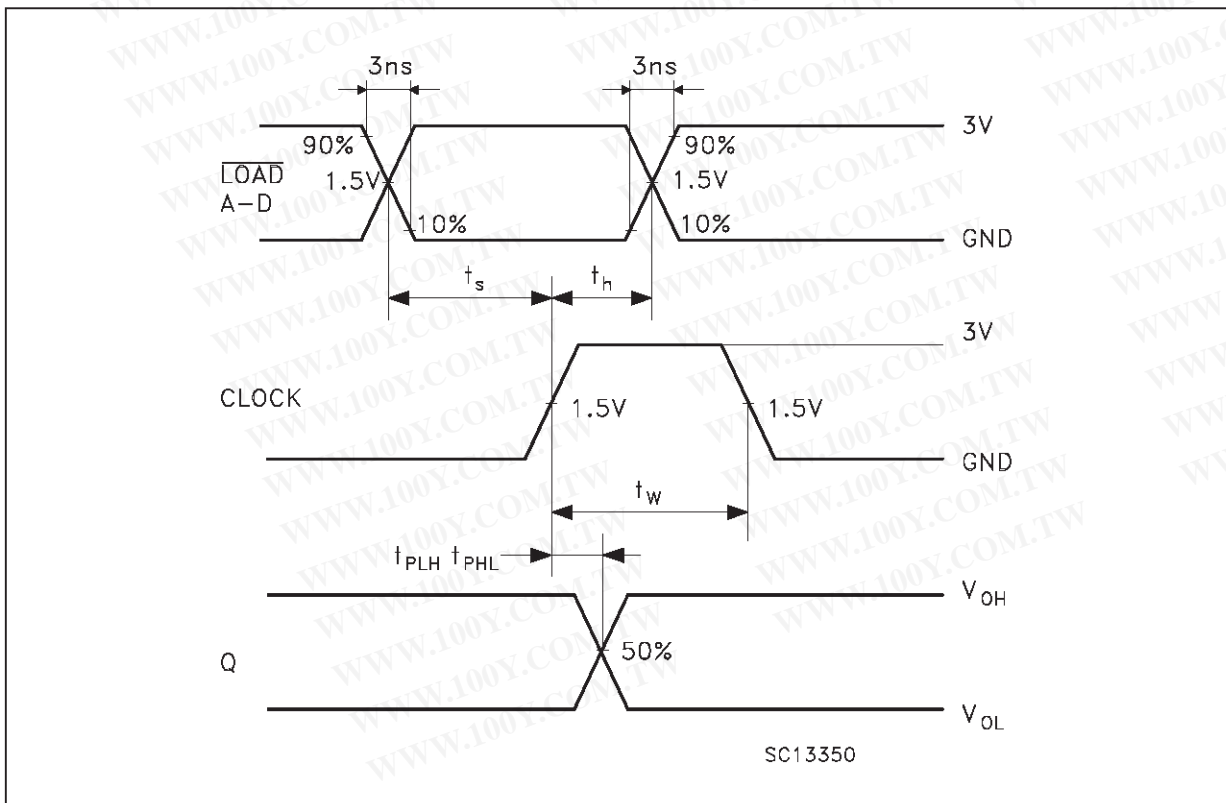

74ACT161

WAVEFORM 4: PROPAGATION DELAYS COUNTABLE MODE (f=1MHz; 50% duty cycle)

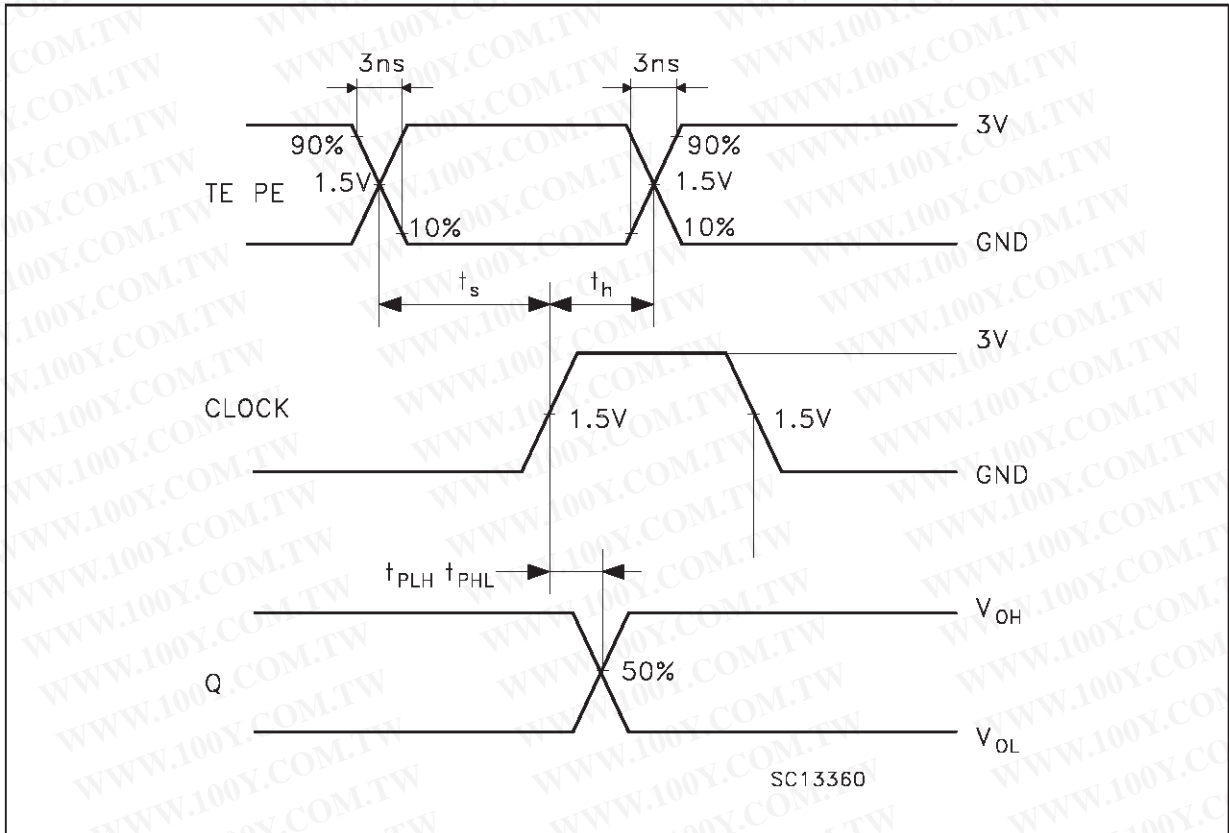

WAVEFORM 5: PROPAGATION DELAYS CASCADE MODE (f=1MHz; 50% duty cycle)

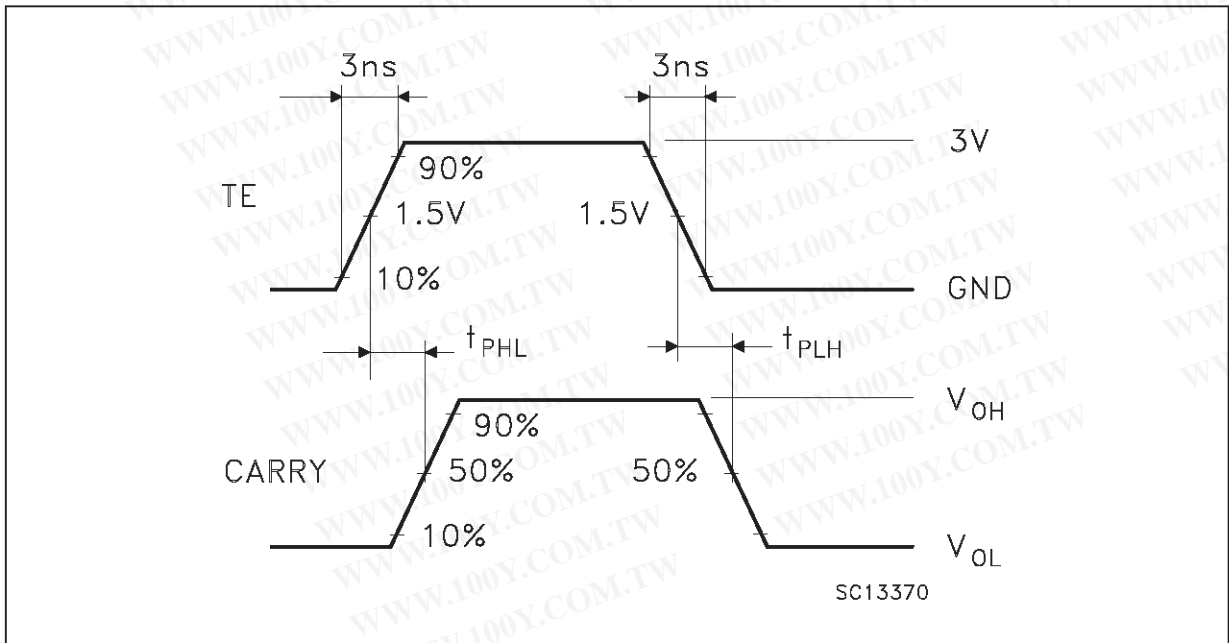

**Plastic DIP-16 (0.25) MECHANICAL DATA**

DIM.	mm			inch		
	MIN.	TYP.	MAX.	MIN.	TYP.	MAX.
a1	0.51			0.020		
B	0.77		1.65	0.030		0.065
b		0.5			0.020	
b1		0.25			0.010	
D			20			0.787
E		8.5			0.335	
e		2.54			0.100	
e3		17.78			0.700	
F			7.1			0.280
l			5.1			0.201
L		3.3			0.130	
Z			1.27			0.050

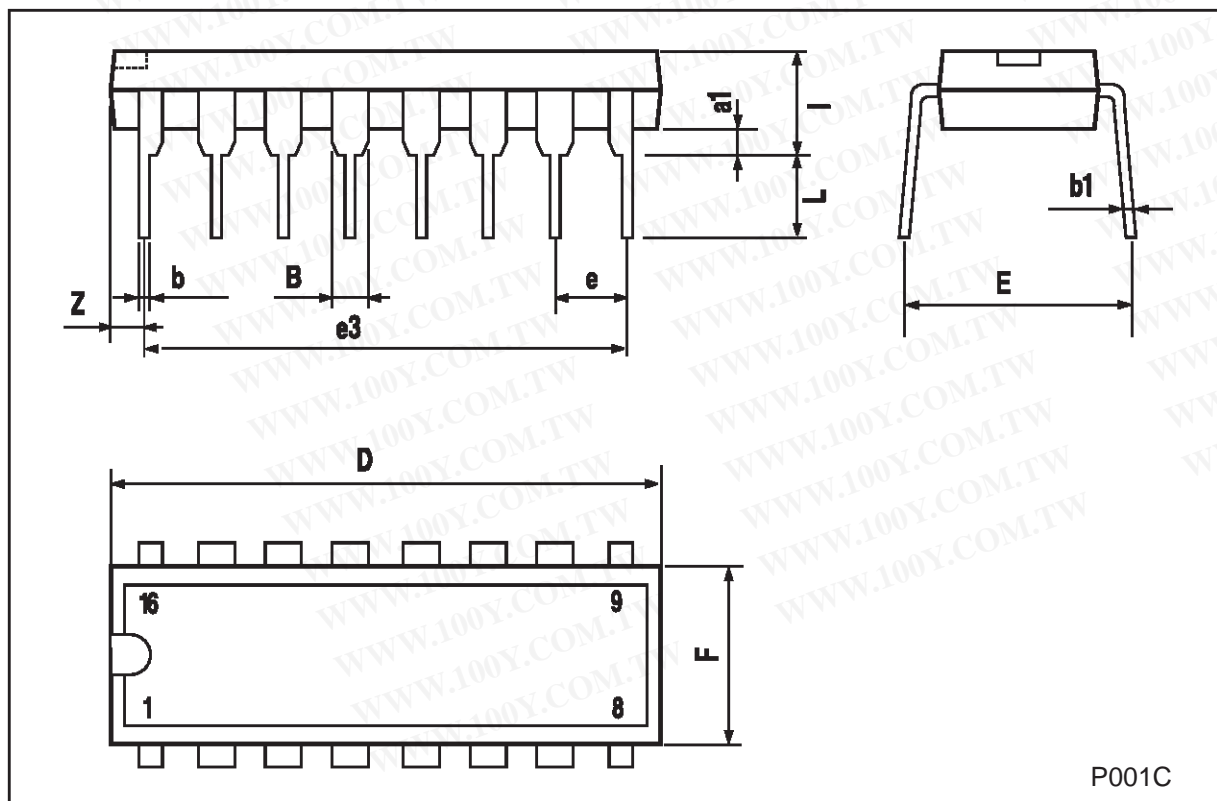

## SO-16 MECHANICAL DATA

DIM.	mm			inch		
	MIN.	TYP.	MAX.	MIN.	TYP.	MAX.
A			1.75			0.068
a1	0.1		0.2	0.004		0.007
a2			1.65			0.064
b	0.35		0.46	0.013		0.018
b1	0.19		0.25	0.007		0.010
C		0.5			0.019	
c1	45 (typ.)					
D	9.8		10	0.385		0.393
E	5.8		6.2	0.228		0.244
e		1.27			0.050	
e3		8.89			0.350	
F	3.8		4.0	0.149		0.157
G	4.6		5.3	0.181		0.208
L	0.5		1.27	0.019		0.050
M			0.62			0.024
S	8 (max.)					

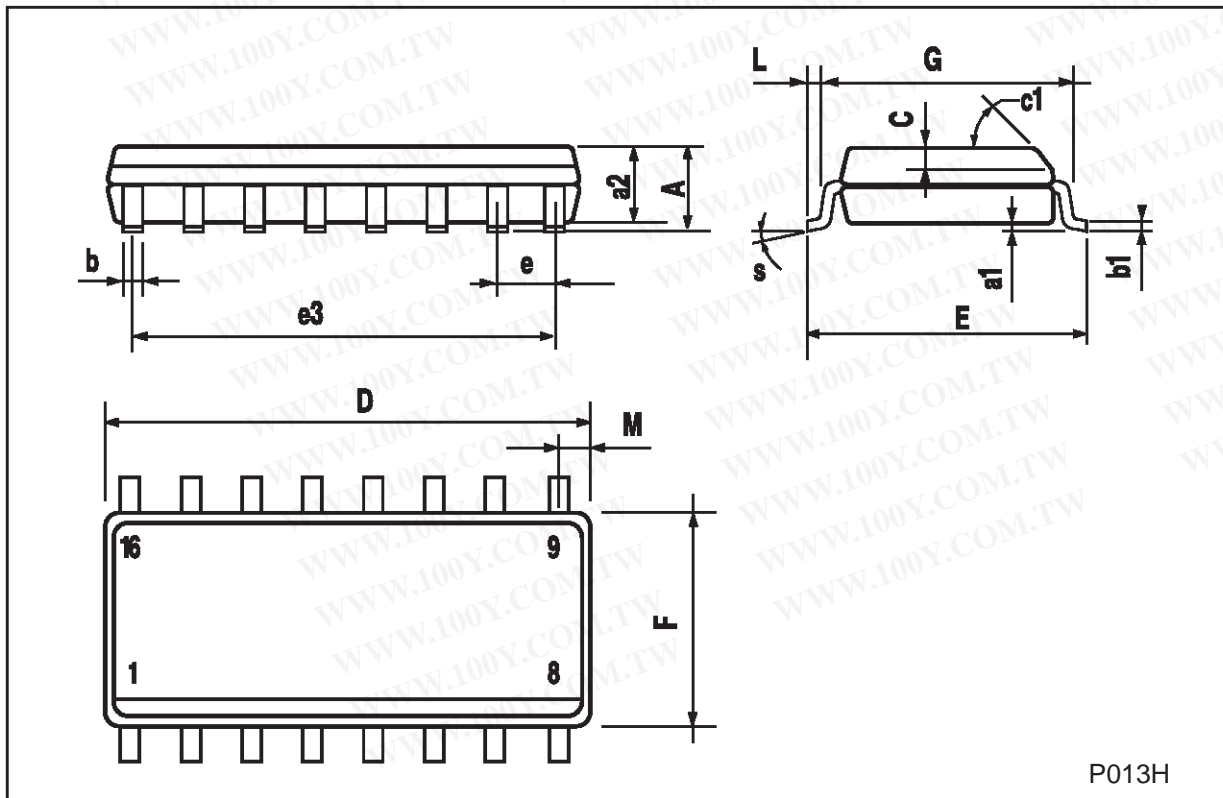

P013H

勝特力材料 886-3-5753170  
勝特力电子(上海) 86-21-54151736  
勝特力电子(深圳) 86-755-83298787  
[Http://www.100y.com.tw](http://www.100y.com.tw)

Information furnished is believed to be accurate and reliable. However, STMicroelectronics assumes no responsibility for the consequences of use of such information nor for any infringement of patents or other rights of third parties which may result from its use. No license is granted by implication or otherwise under any patent or patent rights of STMicroelectronics. Specification mentioned in this publication are subject to change without notice. This publication supersedes and replaces all information previously supplied. STMicroelectronics products are not authorized for use as critical components in life support devices or systems without express written approval of STMicroelectronics.

The ST logo is a registered trademark of STMicroelectronics

© 1998 STMicroelectronics – Printed in Italy – All Rights Reserved  
STMicroelectronics GROUP OF COMPANIES

Australia - Brazil - Canada - China - France - Germany - Italy - Japan - Korea - Malaysia - Malta - Mexico - Morocco - The Netherlands - Singapore - Spain - Sweden - Switzerland - Taiwan - Thailand - United Kingdom - U.S.A.

<http://www.st.com>

