

# TELEDYNE RELAYS

## COMMERCIAL/INDUSTRIAL TO-5 RELAYS DPDT

**SERIES  
712**

SERIES DESIGNATION	RELAY TYPE
712	DPDT basic relay
712D	DPDT relay with internal diode for coil transient suppression
712TN	DPDT relay with internal transistor driver and coil transient suppression diode

### INTERNAL CONSTRUCTION

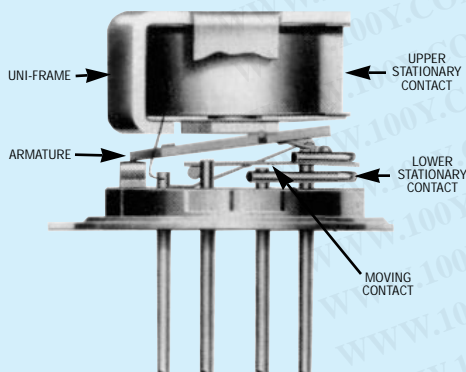

### DESCRIPTION

The TO-5 relay, originally conceived and developed by Teledyne, has become one of the industry standards for low level switching from dry circuit to 1 ampere. Designed expressly for high density PC Board mounting, its small size and low coil power dissipation make the TO-5 relay one of the most versatile ultraminiature relays available.

The following unique construction features and manufacturing techniques provide excellent resistance to environmental extremes and overall high reliability:

- All welded construction.
- Unique uni-frame design providing high magnetic efficiency and mechanical rigidity.
- High force/mass ratios for resistance to shock and vibration.
- Advanced cleaning techniques provide maximum assurance of internal cleanliness.
- Precious metal alloy contact material with gold plating assures excellent high current and dry circuit switching capabilities.

The 712D Series utilizes an internal discrete silicon diode, for coil transient protection. The hybrid 712TN Series features an internal silicon diode and transistor driver. The integrated packaging of the relay with its associated semiconductor devices greatly reduces PC Board floor space requirements as well as component installation costs.

By virtue of its inherently low intercontact capacitance and contact circuit losses, the TO-5 relay has shown itself to be an excellent ultraminiature RF switch for frequency ranges well into the UHF spectrum. A typical RF application for the TO-5 relay is in hand held radio transceivers, wherein the combined features of good RF performance, small size, low coil power dissipation and high reliability make it a preferred method of Transmit-Receive switching (see Figure 1).

ENVIRONMENTAL AND PHYSICAL SPECIFICATIONS	
Temperature (Ambient)	-55°C to +85°C
Vibration	10 g's to 500 Hz (Note 3)
Shock	30 g's for 6 msec. (Note 3) half-sine
Enclosure	Hermetically sealed
Weight	0.09 oz (2.6 gms.) max.

勝特力材料 886-3-5753170  
 勝特力电子(上海) 86-21-54151736  
 勝特力电子(深圳) 86-755-83298787  
[Http://www.100y.com.tw](http://www.100y.com.tw)

GENERAL ELECTRICAL SPECIFICATIONS (@ 25°C) (Notes 1 & 2)

Contact Arrangement	2 Form C (DPDT)	
Rated Duty	Continuous	
Contact Resistance (Note 4)	0.15 ohm max. before life: 0.25 ohm max. after life at 1A/28VDC, (measured 1/8" from header)	
Contact Load Rating (DC) (See Fig. 2 for other DC resistive voltage/current ratings)	Resistive: 1 Amp/28VDC Inductive: 200 mA/28VDC (320 mH) Lamp: 100 mA/28VDC Low Level: 10 to 50 µA/10 to 50 mV	
Contact Load Ratings (AC)	Resistive: 250 mA/115VAC, 60 and 400Hz (Case not grounded) 100 mA/115VAC, 60 and 400Hz (Case grounded)	
Contact Life Ratings	10,000,000 cycles (typical) at low level 1,000,000 cycles (typical) at 0.5A/28VDC resistive 100,000 cycles min. at all other loads specified above	
Contact Overload Rating	2A/28VDC Resistive (100 cycles min.)	
Contact Carry Rating	Contact factory	
Coil Operating Power	450 milliwatts typical at nominal rated voltage	
Operate Time	4.0 msec. max. at nominal rated coil voltage (712TN Series: see Note 6)	
Release Time	712 Series: 3.0 msec. max.	712D, 712TN Series: 6.0 msec. max.
Intercontact Capacitance	0.4 pf typical	
Insulation Resistance	1,000 megohms min. between mutually isolated terminals	
Dielectric Strength	Atmospheric pressure: 350 VRMS/60 Hz	
Diode P.I.V. (VDC) 712D, 712TN		60 min.
Negative Coil Transient (VDC) 712D, 712TN		2.0 max.
712TN Transistor Characteristics	Base Voltage to Turn Off (VDC)	0.3 min.
	Emitter-base breakdown (BV <sub>EB0</sub> ) (VDC)	6.0 min.
	Collector-base breakdown Voltage (BV <sub>CB0</sub> ) (@ 25°C & I <sub>c</sub> = 100 µA) (VDC)	60 min.

DETAILED ELECTRICAL SPECIFICATIONS (@ 25°C) (Note 2)

	BASE PART NUMBERS	712-5	712-6	712-9	712-12	712-18	712-26
		712D-5 712TN-5	712D-6 712TN-6	712D-9 712TN-9	712D-12 712TN-12	712D-18 712TN-18	712D-26 712TN-26
Coil Voltage (VDC)	Nom.	5.0	6.0	9.0	12.0	18.0	26.5
	Max.	5.8	8.0	12.0	16.0	24.0	32.0
Coil Resistance (Ohms ± 20% @ 25°C) (Note 4)		50	98	220	390	880	1560
Pick-up Voltage (VDC, Max.) Pulse Operated (712TN SERIES – See Note 6)		3.6	4.2	6.5	8.4	13.0	17.0
Base Current to Turn On (mADC, Min.) (Note 6)		3.00	2.04	1.36	1.03	0.68	0.50

勝特力材料 886-3-5753170  
 勝特力电子(上海) 86-21-54151736  
 勝特力电子(深圳) 86-755-83298787  
[Http://www.100y.com.tw](http://www.100y.com.tw)

PERFORMANCE CURVES (NOTE 1)

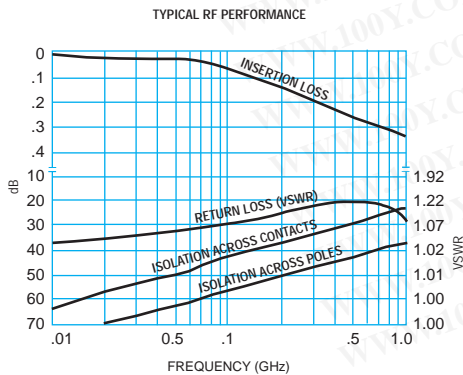

FIGURE 1

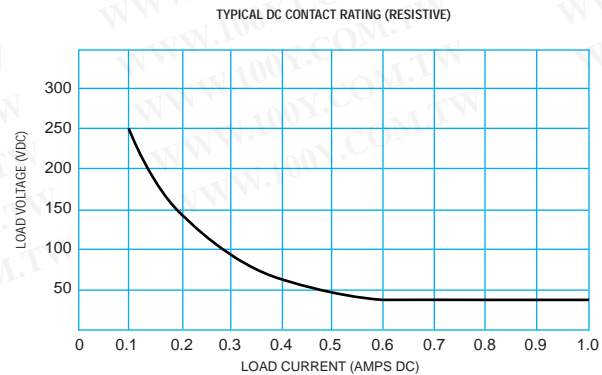
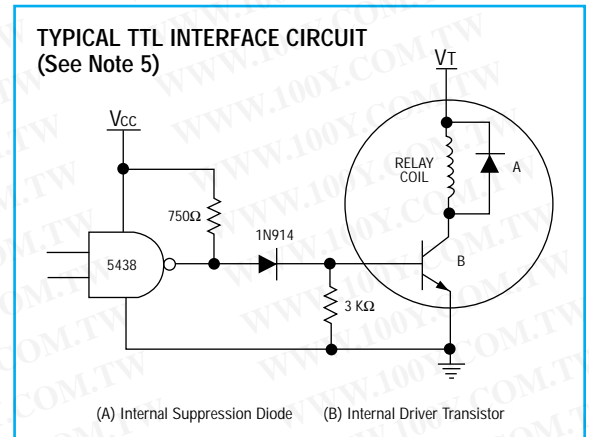
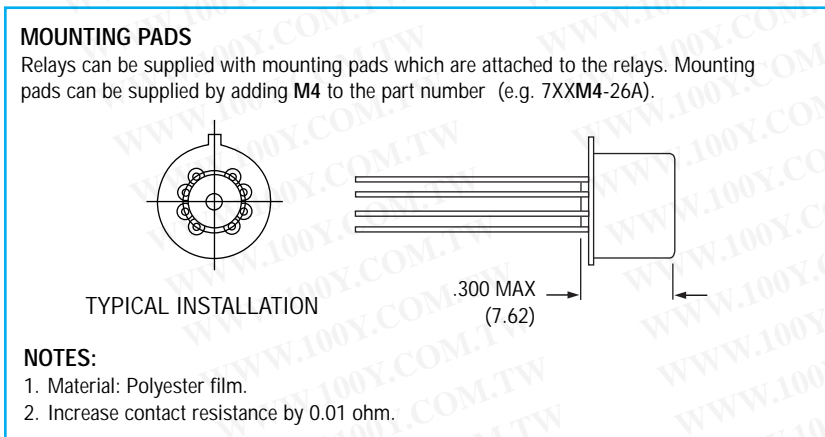
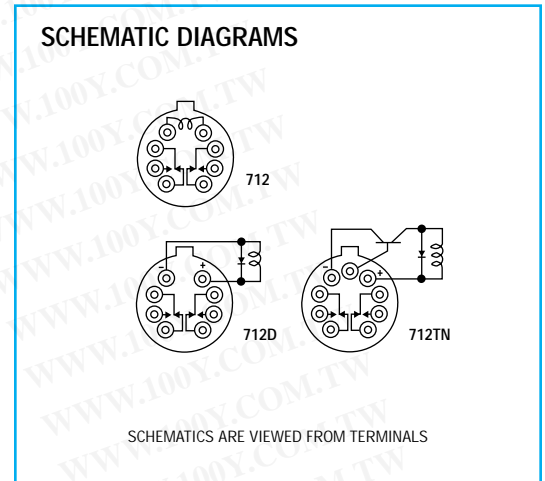
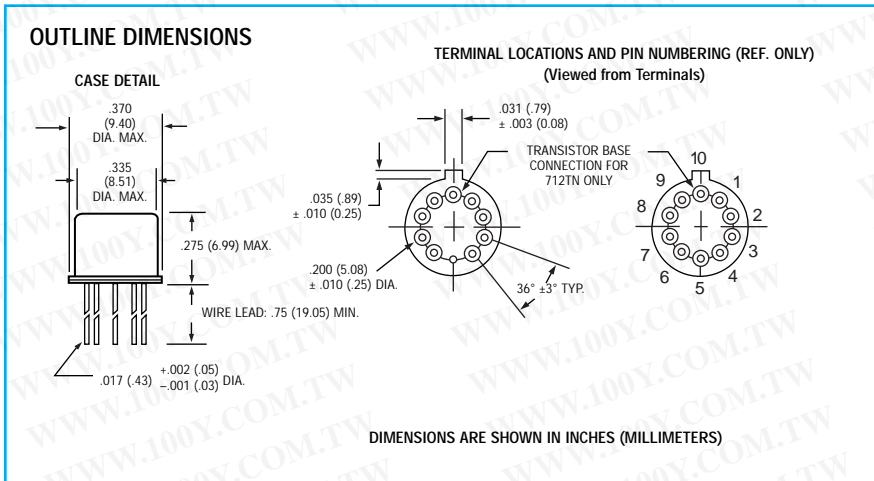

FIGURE 2



### NOTES:

1. Characteristics shown as "typical" are based on available data and are best estimates. No on-going verification tests are performed.
2. Unless otherwise specified, parameters are initial values.
3. Relays will exhibit no contact chatter in excess of 10 µsec or transfer in excess of 1 µsec.
4. For Reference Only. Coil Resistance not directly measurable on 712TN Relays.
5. Circuit is typical for all 712TN Series. Values shown are for 712TN-5 relay, and apply over full operating temperature range.
6. Limit base-emitter current to 15 mA DC.

勝特力材料 886-3-5753170  
 勝特力电子(上海) 86-21-54151736  
 勝特力电子(深圳) 86-755-83298787  
[Http://www.100y.com.tw](http://www.100y.com.tw)