

Contact Points

Optional Accessory for Digimatic and Dial Indicators and Linear Gages

SPECIFICATIONS

勝特力材料 886-3-5753170
 勝特力电子(上海) 86-21-34970699
 勝特力电子(深圳) 86-755-83298787
 Http://www.100y.com.tw

Ball Point

Standard contact point.

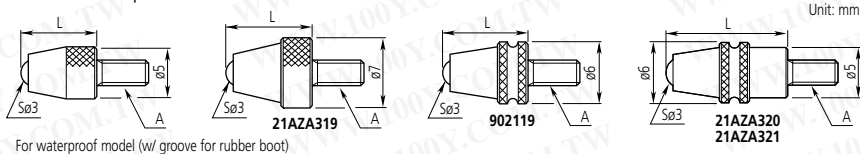

A: M2.5x0.45

L	Material		Material	
	Carbide	Ruby	Carbide	Plastic
	Without groove	With groove (waterproof type)	Without groove	Without groove
7.3	901312	—	120047	901994
8.3	21AZA319	902119	—	—
12.1	—	21AZA320	—	—
14	21JAA225	—	—	—
15	120049	—	120051	—
17	21JAA224	—	—	—
19.3	—	21AZA321	—	—
20	137391	—	137392	—
22	21JAA226	—	—	—
25	120053	—	120055	—
30	21AAA252	—	21AAA253	—

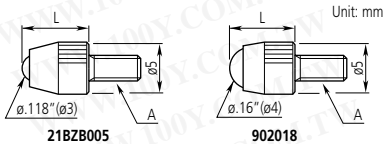

A: 4-48UNF

L	Material	
	Carbide	Plastic
1/4"	21BZB005	902018

Ball Point

Optimal for workpieces with deep indentations.

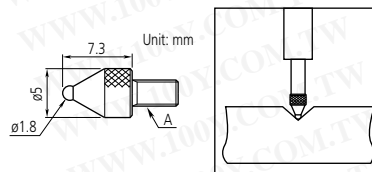

A: M2.5x0.45

∅D	∅d	Order No.
1mm, carbide	5mm	21AAA349
1.5mm, carbide	5mm	21AAA350
1.8mm, steel	5mm	101122
2.5mm, carbide	5mm	21AAA351
4mm, carbide	5mm	21AAA352

Shell Type Point

Contact point with a large radius.
Optimal for use on flat surfaces.

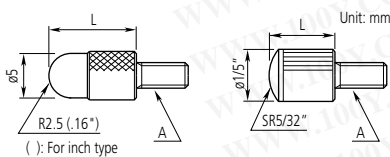

A: M2.5x0.45

L	Order No.
5	101386
10	101118
15	137393
20	101387
25	101388
30	21AAA254

A: 4-48UNF

L	Order No.
3/32"	193697
5/32"	101184
1/4"	21AAA031
3/8"	21AAA032
1/2"	101185
5/8"	21AAA033
3/4"	101186
7/8"	21AAA034
1"	101187
1 1/4"	21AAA035
1 1/2"	21AAA036
1 3/4"	21AAA037
2"	21AAA038
2 1/4"	21AAA039
2 1/2"	21AAA040
2 3/4"	21AAA041
3"	21AAA042

Spherical Point

A large radius makes this contact point optimal for use where the workpiece needs to slide from the side.

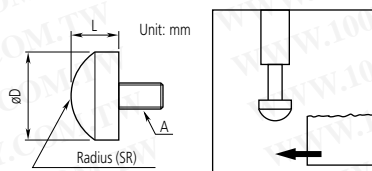

A: M2.5x0.45

D	L	SR	Order No.
5.5	3	5	111460
7.9	5	5	125258
10	5	7	101119

A: 4-48UNF

D	L	SR	Order No.
1/2"	1/8"	.35"	101205
3/8"	3/32"	.28"	101204

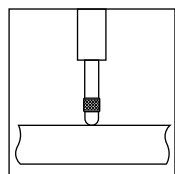

Spherical Point (Carbide)

A large radius makes this contact point optimal for use where the workpiece needs to slide from the side.

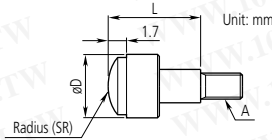

A: M2.5x0.45

D	L	SR	Order No.
5.2	5	5	120058
7.5	10	7	120059
10.5	10	10	120060

Conical Point

Used for positioning the measurement point. Since it can damage a workpiece easily, it is not suitable for use on soft materials.

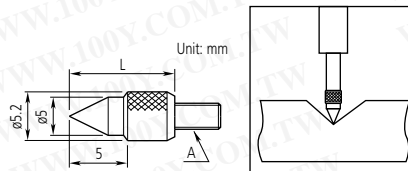

A: M2.5x0.45

Tip angle	L	Order No.
60°	10	101120

A: 4-48UNF

L	A	Order No.
1/2"	.2"	101190

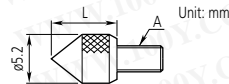

A: M2.5x0.45

Tip angle	L	Order No.
90°	5	101385

A: 4-48UNF

D	L	Order No.
.2"	1/4"	101191

Knife Edge Point (Carbide)

Suitable for measuring narrow groove diameter, etc.

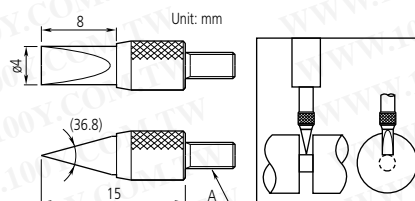

A: M2.5x0.45

Order No.
120067

Conical Point (Carbide)

Used for positioning the measurement point. Since it can damage a workpiece easily, it is not suitable for use on soft materials.

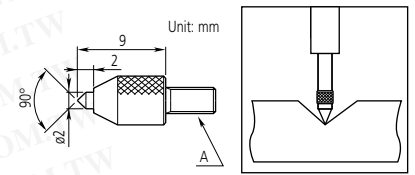

A: M2.5x0.45

Order No.
120057

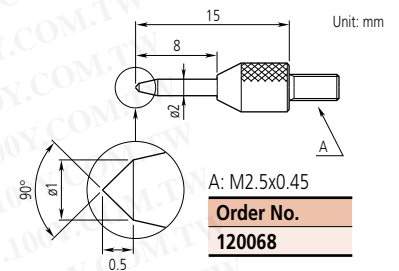

A: M2.5x0.45

Order No.
120068

Flat Point

Optimal for use on convex surfaces.

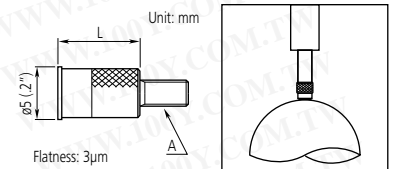

A: M2.5x0.45

L	Order No.
8	131365
10	21AAA340

A: 4-48UNF

L	Order No.
5/16"	133017
1/2"	21AAA043
3/4"	21AAA044
1"	21AAA045

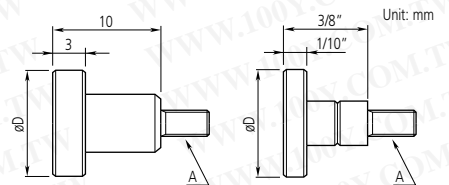

A: M2.5x0.45

D	Order No.
10	10117
15	21AAA341
20	21AAA342
25	21AAA343
30	21AAA344

A: 4-48UNF

D	Order No.
1/2"	101188
3/8"	101189

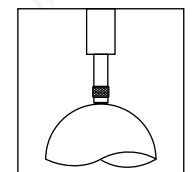

Flat Point (Carbide)

Optimal for use on convex surfaces.

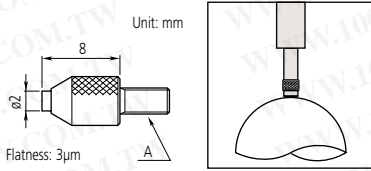

A: M2.5x0.45

Order No.
120056

Needle Point

Suitable for probing the bottom of a groove or hole.

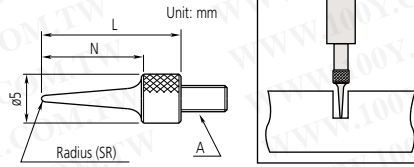

A: M2.5x0.45

N	L	SR	Order No.
11	15	0.4	101121
13	17	0.2	137413
21	25	0.4	21AAA255
31	35	0.4	21AAA256

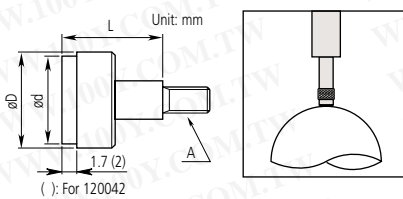

A: M2.5x0.45

D	d	L	Order No.
5.2	4.3*	5	120041
7	6.5*	10	120042
10.5	9.5*	10	120043
17	15**	10	21AAA345
22	20**	10	21AAA346
27	25**	10	21AAA347
32	30**	10	21AAA348

Flatness: * $3\mu\text{m}$, ** $5\mu\text{m}$

A: 4-48UNF

L	SR	Order No.
.6"	.016"	21AAA030
1"	.016"	21AAA046
1 1/2"	.016"	21AAA047
2"	.016"	21AAA048

Needle Point (Carbide)

Suitable for probing the bottom of a groove or hole.

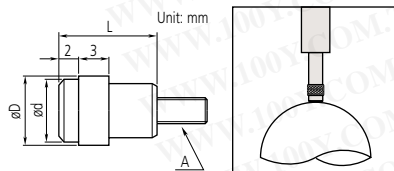

A: M2.5x0.45

D	d	L	Order No.
7	6.4	10	137255
9	8	10	137399

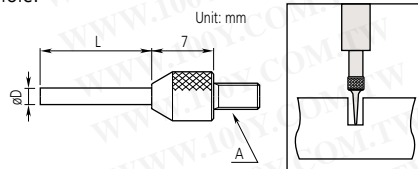

A: M2.5x0.45

D	L	Order No.
0.45	3	120066
0.45	5	21AAA329
1	3	120065
1	5	21AAA330
1	8	21AAA331
1	10	21AAA332
1.5	5	21AAA335
1.5	10	21AAA336
1.5	13	120064
1.5	20	21AAA337
1.5	40	21AAA338
2	8	137257
2	18	21AAA257
2	28	21AAA258
2	40	21AAA339

Lever Point

Suitable for use on perpendicular faces, such as those within mold cavities. Lever can be adjusted to the required angle.

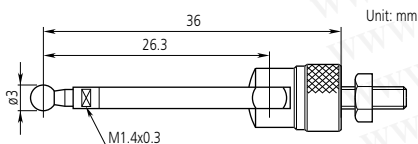

A: M2.5x0.45

Order No.
900391

A: 4-48UNF

Order No.
900393

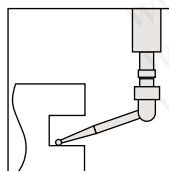

Blade Point (Carbide)

Suitable for use on convex surfaces, especially those with shallow grooves.

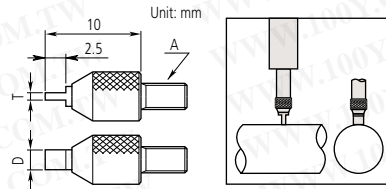

A: M2.5x0.45

T	W	Order No.
0.4	2	120061
0.6	2	120062
1	4	120063

Roller Point

Suitable for use on a moving workpiece surface, or where the workpiece needs to slide from the side.

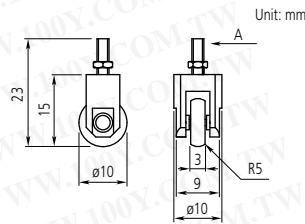

A: M2.5x0.45

Order No.
901954

A: 4-48UNF

Order No.
901991

Extension Rod

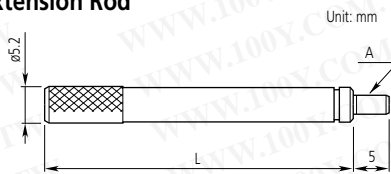

A: M2.5x0.45

L	Order No.
10	303611
15	21AAA259A
20	303612
25	21AAA259B
30	303613
35	21AAA259C
40	21AAA259D
45	21AAA259E
50	21AAA259F
55	21AAA259G
60	304146
65	21AAA259H
70	21AAA259J
75	21AAA259L
80	21AAA259M
90	304147
100	303614

A: 4-48UNF

L	Order No.
1/2"	139167
1"	301655
2"	301657
4"	301659

Interchangeable Contact Point Set

This set consists of six types of popular contact point for extending the use of an indicator to many applications.



A: M2.5x0.45

Order No.	Contact points included
7822	Flat Point (131365, φ5mm)
	Flat Point (101117, φ10mm)
	Needle Point (101121)
	Spherical Point (101119)
	Shell Type Point (101118)
	Shell Type Point (101387)

A: 4-48UNF

Order No.	Contact points included
21AZA034	Shell Type Point (101184, 5/32")
	Shell Type Point (101185, 1/2")
	Shell Type Point (101186, 3/4")
	Shell Type Point (101187, 1")
	Flat Point (101188, φ1/2")
	Flat Point (101189, φ3/8")
	Conical Point (101190, 60°)
	Conical Point (101191, 90°)
	Spherical Point (1011204, φ3/8")
	Lever Point (21AAA030, .6")

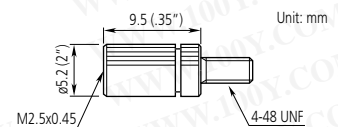

Order No.
21AAA011

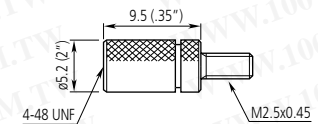











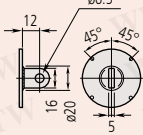

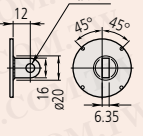

Order No.
21AAA012

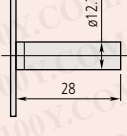
Interchangeable Backs

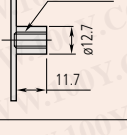
Optional Accessory for Digimatic and Dial Indicators

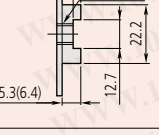
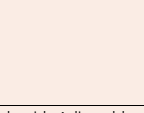
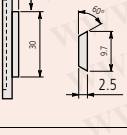
SPECIFICATIONS

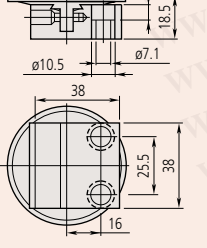
Description	Order No.		
	Series 1 ($\phi 41$ mm)	Series 2 ($\phi 57$ mm)	Series 3, 4 ($\phi 78, 91$ mm)
Flat Back   Unit: mm	101211: a=2.2 136872: for water-proof type 191559: for 1911, 1913-10, 1921, 1923, 1925-10, 1927-10 137906: for 1003	101039: a=2.5 21AZB231: for water-proof of S type 192910: (F type waterproof model)	100836: a=3.0
Lug-on-Center Back   Unit: mm	101210: metric type 101307: inch type 190561: for 1911, 1913-10, 1921, 1923, 1925-10, 1927-10 192910: 137905: for 1003	101040: metric type 101306: inch type 21AZB230: for water-proof of S type (mm) 21BZB104: for water-proof of S type (inch)	100691: metric type 100797: inch type
Magnetic Back   Unit: mm	Special order	900928	900929
Back with Offset Lug   Unit: mm	Special order	101167	100837
Back with Post   Unit: mm	193172 Custom made	101169	100839
Back with Screw Mount   Unit: mm	193173: M6x1, Custom made 193174: #1/4-28UNF, Custom made	136023: M6x1 101170: #1/4-28UNF	136024: M6x1 100840: #1/4-28UNF
Adjustable Back   Unit: mm	136025: M6x1 129721: #1/4-20UNF	136026: M6x1 101168: #1/4-20UNF)	136027: M6x1 100838: #1/4-20UNF
Back with Dovetail   Unit: mm	—	900008	Special order
Back with Adjustable Bracket   Unit: mm	—	901963	—

A dial or Digimatic indicator may be held in position by clamping on either the stem or the lug on the back of the indicator. The back of the indicator may need to be interchanged with another type for special applications. A wide variety of backs are available for Mitutoyo Digimatic and dial indicators.

Application

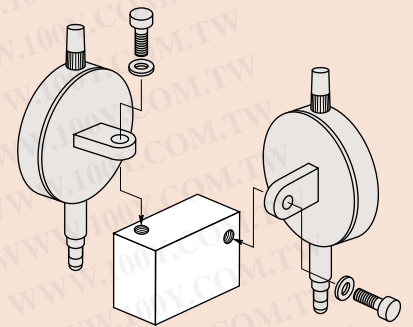

Spindle Lifting Lever and Cable

Optional Accessories for Digimatic and Dial Indicators

Spindle Lifting Lever

- The Spindle Lifting Lever is attached to the top end of the spindle for improved inspection efficiency when using a dial indicator mounted on a stand.

902100

Use for S type Series 1 and F type Series 2 (up to 10mm/.4" range) dial indicators.



21AZB149

Use for S type Series 2, 3, and 4 dial indicators (up to 10mm/.4").



21AZB150

Use for S type Series 2 and 3 dial indicators (from 10mm/.4" up to 20mm/.8").



Spindle Lifting Cable

901975: with auto-stop function



Spindle Lifting Knob

137693

Suitable for 4.8mm spindle diameter.



Application

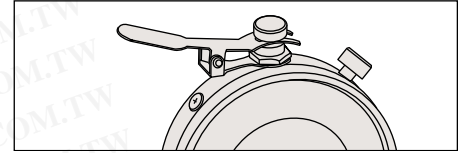
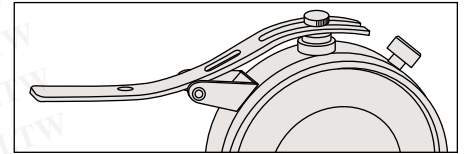

21BZA205

Use for F type Series 1 dial indicators.



900527: Lever
101171: Screw

902011

Use for F type Series 2 dial indicators (up to 10mm/.4" range).



903424

Use for F type Series 2 dial indicators (up to 20mm/.8" range) and Series 3 and 4 dial indicators (up to 10mm/.4" range).



903307: Lever
192686: Screw

Application

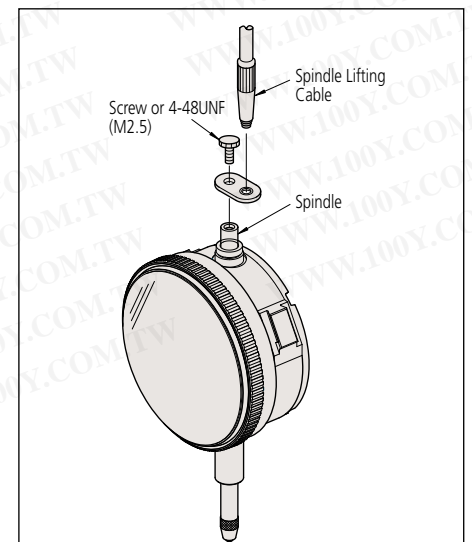

Color-coded Spindle Caps

Optional Accessory for Digimatic and Dial Indicators

8 color-coded spindle caps are available for dial indicators with a range of 10mm or less.



SPECIFICATIONS

Color	Order No. (normal)	Order No. (water-resistant)
Black	193051	193595
White	193051W	193595W
Red	193051R	193595R
Green	193051G	193595G
Blue	193051B	193595B
Yellow	193051Y	193595Y
Orange	193051D	193595D
Pink	193051P	193595P
Dark blue	193051S	193595S

Limit Stickers

Optional Accessory for Digimatic and Dial Indicators

FEATURES

- Stuck on the dial face or crystal of a Series 2 dial indicator (55.6mm or 57mm bezel dia.) to indicate tolerance limits.



136420: Red (10-sheet/set)



136421: Green (10-sheet/set)



136422: Yellow (10-sheet/set)

Dial Indicator Repair Tool Kit

Optional Accessory for Digimatic and Dial Indicators

Set Configuration

- 901171: Grease
- 21JAA273: Reamer for pointer (ø0.5:1/20 taper)
- 21JAA313: Lubricating oil
- 21JAA314: Stick
- 901173: Screwdriver (Phillips)
- 901174: Screwdriver (Phillips/flat blade)
- 126628: Pointer removing
- 126630: Pointer removing (ø0.8)
- 126630B: Pointer removing (ø0.5)
- 126630C: Pointer removing (ø1.6)
- 129729: Tweezers
- 901175: Pin-vise
- 901176: Brush
- 901177: Brush
- 901178: Hammer
- 129730: Spindle rest
- 129731: Pin rest
- 901179: Nippers
- 901180: Pliers
- 901181: Hand remover
- 129732: Pin remover
- 129733: Punch
- 129734: Bearing adjuster
- 129735: Pinion rest
- 129736: Reamer ø1
- 193702: Reamer ø0.6
- 901182: Case
- 100699: Adjustable nut

Mitutoyo offers a tool set designed to let you perform simple repairs to your Mitutoyo dial indicator, and a device that lets you replace indicator crystals.

勝特力材料 886-3-5753170
勝特力电子(上海) 86-21-34970699
勝特力电子(深圳) 86-755-83298787
[Http://www.100y.com.tw](http://www.100y.com.tw)



7823

Dial Indicator Crystal Setter

Optional Accessory for Digimatic and Dial Indicators

FEATURES

- Used for fitting a crystal on dial indicators, dial test indicators, and dial calipers.



7000

With 8 sizes of crystal setting pad