

New Products

勝特力材料 886-3-5753170
勝特力电子(上海) 86-21-54151736
勝特力电子(深圳) 86-755-83298787
[Http://www.100y.com.tw](http://www.100y.com.tw)

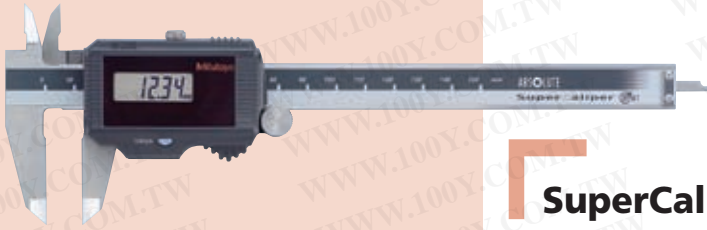

SuperCaliper

Refer to pages D-3-D-4 for details.

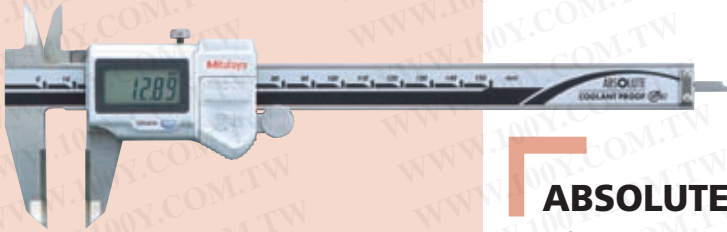

ABSOLUTE Coolant Proof Caliper

Refer to pages D-5-D-6 for details.



ABSOLUTE Digimatic Caliper

Refer to pages D-7-D-8 for details.



ABSOLUTE Digimatic Offset Caliper

Refer to page D-28 for details.



Digimatic Height Gage

Refer to pages D-43-D-60 for details.



D

Small Tool Instruments Calipers Height Gages Depth Gages

Digimatic Caliper·Caliper

Digimatic Caliper·Caliper



INDEX

Digimatic Calipers

SuperCaliper	D-3
ABSOLUTE Coolant Proof Caliper	D-5
ABSOLUTE Digimatic Caliper	D-7
Long ABSOLUTE Digimatic Caliper	D-9
ABSOLUTE Solar Caliper	D-10

Calipers

Vernier Caliper	D-11
ABSOLUTE Digimatic Caliper	D-15
Dial Caliper	D-17
ABSOLUTE Coolant Proof Carbon Fiber Caliper	D-19
Vernier Caliper (Nib Style Jaws)	D-25
Long Jaw Vernier Caliper	D-26
Offset Caliper	D-28
Offset Centerline Caliper	D-29
ABSOLUTE Back-Jaw Centerline Caliper	D-30
Point Caliper	D-31
Blade Type Caliper	D-32
ABSOLUTE Inside Caliper	D-33
Neck Caliper	D-35
Tube Thickness Caliper	D-36
Hook Type Vernier Caliper	D-37
Swivel Vernier Caliper	D-37
ABSOLUTE Low Force Caliper	D-38
ABSOLUTE Snap Caliper	D-39
Quick Guide to Precision Measuring Instruments	D-41

Digimatic Height Gages

Digimatic Height Gage	D-43
ABSOLUTE Digimatic Height Gage	D-47

Height Gages

Vernier Height Gage	D-51
Dial Height Gage	D-52
CERA Caliper Checker	D-53
Optional accessories	D-54

Linear Height

Linear Height	D-55
QM-Height	D-57
Quick Guide to Precision Measuring Instruments	D-59

Depth Gages

Depth Micrometer	D-61
Depth Micro Checker	D-63
ABSOLUTE Digimatic Depth Gage (SERIES 571)	D-64
Vernier Depth Gage	D-65
Depth Gage	D-66
Dial Depth Gage (SERIES 527 - with Fine Adjustment)	D-67
Extension Bases	D-68
Depth Gage Attachment	D-68
Dial Depth Gage (SERIES 7)	D-69
ABSOLUTE Digimatic Depth Gage (SERIES 547)	D-70

Digimatic Height Gage·Height Gage

Digimatic Height Gage·Height Gage

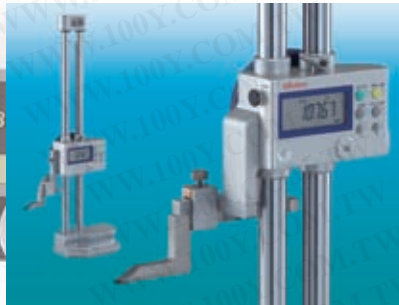

Height Gage

Height Gage



Depth Gage

Depth Gage



Calipers

An industry standard in measuring tools

SuperCaliper

SERIES 500 — No battery or origin reset needed for IP67 digital caliper

- Top-of-the-line digital caliper. Solar type caliper with no battery and IP67 protection assures waterproof reliability.

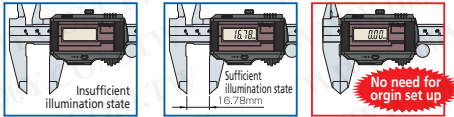

- With no annoying origin restoration necessary, a measurement can be started any time and there is no restriction on operating speed.
- The impact resistance of the display unit has been increased for improved usability in workshop conditions.

- Waterproof function makes this SuperCaliper suitable for use in an environment containing large amounts of cutting fluid or coolant. Operability is equivalent to the mechanical type caliper.

- This SuperCaliper uses components that do not contain harmful substances and is compatible with RoHS Directives.
- Slider operation is smooth and comfortable.

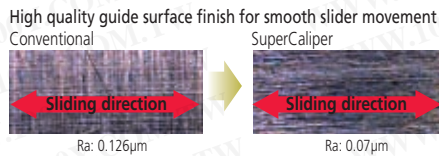

500-774

SPECIFICATIONS

Metric			
Order No.	Range	Remarks	Mass
500-776	0 - 150mm	with data output	180g
500-777	0 - 200mm		210g
500-774	0 - 150mm	w/o data output	180g
500-775	0 - 200mm		210g

Inch/metric			
Order No.	Range	Remarks	Mass
500-786	0 - 6"	with data output	180g
500-787	0 - 8"		210g
500-784	0 - 6"	w/o data output	180g
500-785	0 - 8"		210g

DIMENSIONS

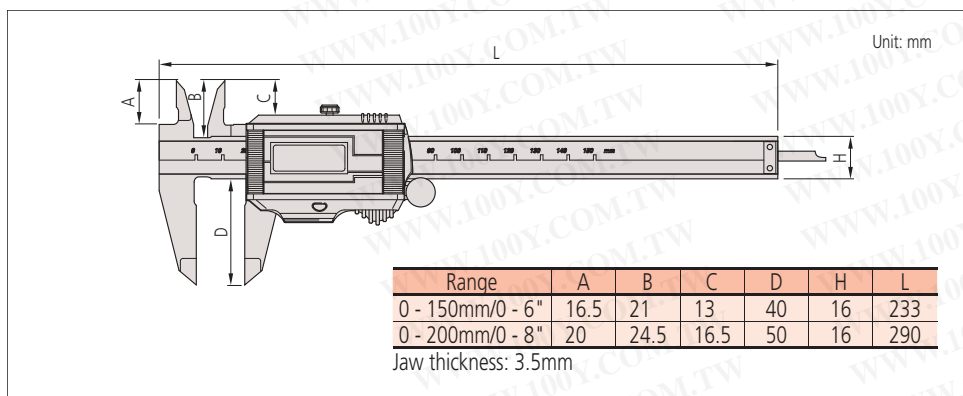

ABSOLUTE™ (Refer to page IX for details.)



(Refer to page IX for details.)



(Refer to page IX for details.)

www.tuv.com
ID 000006883



An inspection certificate is supplied as standard. Refer to page IX for details.

IP67 protection level

Level 6: Dust-proof.
No ingress of dust allowed.

Level 7: Protected against water penetration.
Ingress of water in quantities causing harmful effects shall not be possible when the enclosure is temporarily immersed to a depth of 1 meter in water under standardized conditions of pressure and time (30 min.).



Demonstration device

Technical Data

Resolution: 0.01mm or .0005"/0.01mm
Accuracy: ±0.02mm (excluding quantizing error)
Repeatability: 0.01mm
Quantizing error: ±1 count
Dust/Water protection level: IP67*
Power supply: Solar cell**
Display: LCD
Scale type: ABSOLUTE electromagnetic induction linear encoder
Max. response speed: Unlimited
* This model is not waterproof type. Therefore, rustproofing shall be applied after use.
** Can be used continuously above 60lux ambient illumination.



Functions

Origin-set: Absolute origin position can be changed.

Alarm: Error message is displayed and measurement functions become inoperative if:

- Tool is turned on when both illumination and charging voltage are insufficient.
- Main unit is extremely polluted and miscalculation occurs in the display unit.



Air leak test equipment for water resistance inspection

Generally, an air leak test is adopted for evaluating water resistance.

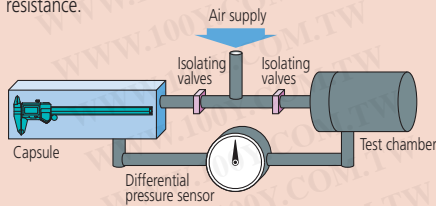

Procedure: Place the measuring tool inside the capsule and seal it. Then fill the capsule and the test chamber with air at the required pressure and close the isolating valves. If there is no leak in the measuring tool, the differential pressure sensor will read zero, because the amount of air inside the test chamber is unchanging. However, if there is a leak in the measuring tool, the differential pressure sensor will show a non-zero reading due to a decrease in pressure inside the test chamber as air leaks into the tool. By detecting this differential pressure, GO/NG judgment for the severity of the leak is performed. This air leak test is performed for all ABS coolant proof calipers and coolant proof micrometers.



Air leak test equipment for ABS coolant proof caliper

Optional accessories

(Dedicated for the models equipped with a digimatic output function (Code No. 500-776, 500-777, 500-786 and 500-787))

For details, refer to page A-21.

- **Connecting cables for IT/DP/MUX***
 - 05CZA624: SPC cable with data button (1m)
 - 05CZA625: SPC cable with data button (2m)
- **USB Input Tool Direct**
 - 06ADV380A: SPC cable for USB-ITN-A (2m)
- **Connecting cables for U-WAVE-T**
 - 02AZD790A: SPC cable for U-WAVE with data button (160mm)
 - 02AZE140A: SPC cable for foot switch



* Cannot be used for other than water resistant type Digital calipers with external output function.



About the charge function (SuperCaliper)

The minimum illumination required in the uncharged state is 60lux.

As shown in the table 'JIS Z 9110 Artificial Illumination Intensity Standard', this SuperCaliper can be used with confidence in a normal work environment.

The charge function allows the operator to use the SuperCaliper without interrupting work even if the ambient illumination is temporarily insufficient.

- In the fully charged state this SuperCaliper can operate for approximately one hour in an environment of 50lux illumination (less than the minimum necessary illumination intensity).
- The time necessary for full charge varies according to the charging conditions. If the SuperCaliper is left unused in an illumination of 500 lux (usual for manufacturing environments), it takes approximately one hour to reach full charge.

Illumination (lx)	Site (possible operations)
1500	
1000	Design room, drafting room (Fine visual work)
750	
500	Conference room, control room (Usual manufacturing environment) (Normal visual work)
300	
200	Machine room, electric room, lecture hall (Rough visual work)
150	
100	Corridor, passage, stairs (Very rough visual work)
75	
50	Emergency staircase, warehouse (Loading, unloading work)
30	
20	

Excerpts from JIS Z 9110 Artificial illumination Intensity Standard

Calipers

An industry standard in measuring tools

ABSOLUTE Coolant Proof Caliper SERIES 500 — with Dust/Water Protection Conforming to IP67 Level

- Can be used in workshop conditions exposed to coolant, water, dust or oil. Dimensions, mass and price are the same as the conventional products. Also, 100% inspection by air leak test is performed.
- Carbide-faced jaws with round depth-rod type is newly added to the product lineup.
- Large LCD characters make the display easy to read.
- Easy to use — advanced design styling with only 1 button.
- Incorporates the absolute measurement system. No need to reset the origin.
- The automatic power-on/off function shuts down the LCD display after 20 minutes inactivity, but the ABS scale unit origin is stored. Power is restored when the slider is moved.
- Allows step measurement
- Can be integrated into statistical process control and measurement systems.
- A convenient interface input tool is available so that measurement data can be converted to keyboard signals and input directly to commercial spreadsheet software. Refer to page A-4.
- An inspection certificate is supplied as standard. (However, this cannot be used as a calibration certificate as it is undated.)
- Special type ABS Coolant Proof Calipers are provided.

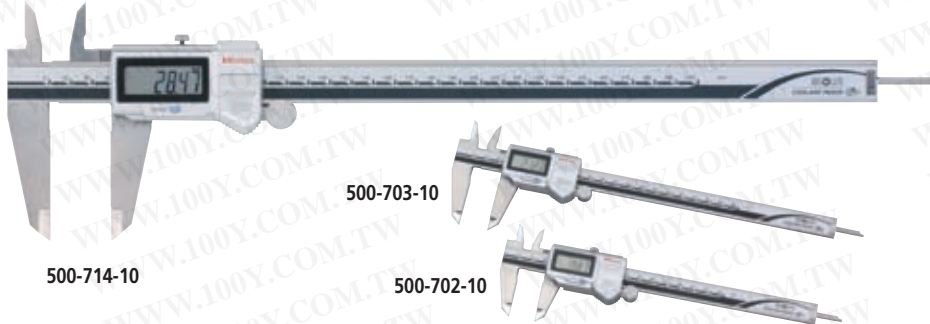

A built-in ABS (absolute) scale means that these calipers are ready to use immediately after power-on without origin resetting – just like using a vernier caliper.

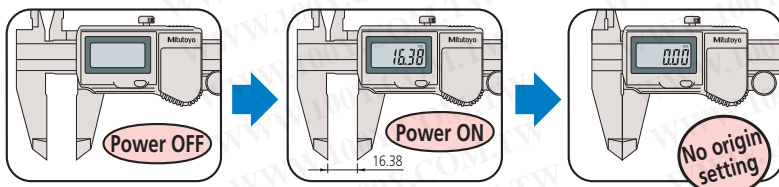

Optional accessories

For details, refer to page A-21.



Connecting cables for IT/DP/MUX*

- 05CZA624: SPC cable with data button (1m)
- 05CZA625: SPC cable with data button (2m)

* Cannot be used for other than water resistant type Digital calipers with external output function



USB Input Tool Direct

- 06ADV380A: SPC cable for USB-ITN-A (2m)

Connecting cables for U-WAVE-T

- 02AZD790A: SPC cable for U-WAVE with data button (160mm)
- 02AZE140A: SPC cable for footswitch

IP67 protection level

IP 6 7

First characteristic number	Protection from solid objects (people or things)		Second characteristic number	Protection from liquids (water, etc.)	
	Brief description	Description		Brief description	Description
6	Dust-proof.	No ingress of dust allowed.	7	Protected against water penetration.	Ingress of water in quantities causing harmful effects shall not be possible when the enclosure is temporarily immersed in water under standardized conditions of pressure and time.

For details of the test conditions used in evaluating each degree of protection, please refer to the original standard.

ABSOLUTE™ (Refer to page IX for details.)

IP67 (Refer to page IX for details.)



(Refer to page IX for details.)



An inspection certificate is supplied as standard. Refer to page IX for details.

Smooth slider movement makes for comfortable operation.

High quality guide surface finish for smooth slider movement

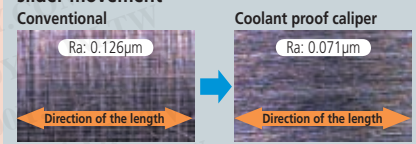

Technical Data

- Accuracy: $\pm 0.02\text{mm}$ ($\leq 200\text{mm}$), $\pm 0.03\text{mm}$ ($> 200\text{mm}$) (excluding quantizing error)
 - Resolution: 0.01mm or .0005"/0.01mm
 - Repeatability: 0.01mm
 - Quantizing error: Not including ± 1 count
 - Dust/Water protection level: IP67 (IEC60529)*
 - Display: LCD
 - Scale type: ABSOLUTE electromagnetic induction linear encoder
 - Max. response speed: Unlimited
 - Battery: **SR44** (1 pc), **938882**, for initial operational checks (standard accessory)
 - Battery life: Approx. 3 years under normal use (1 year: over 300mm models)
- * Although these models are IP67 rated, care should be taken to dry tool after use.

Functions

Origin-set: Absolute origin position can be changed.

Data output: Measurement data output connector allows integration into statistical process control and measurement systems.

Automatic power on/off: LCD display will turn off after 20 minutes inactivity, but the ABS scale unit origin is stored. Power is restored when the slider is moved.

Alarm: Error message is displayed if error in calculation is found and measurement is stopped. Measurement will not be continued while error is displayed. Also, if the battery voltage becomes low, "B" appears to alert the user before measurement is no longer possible.

SPECIFICATIONS

Metric							
Order No.	Range	Depth bar	Fine adjustment	Remarks			
500-702-10*	0 - 150mm	Blade	with thumb roller	—			
500-712-10			—				
500-706-11*		Ø1.9mm rod	—				
500-716-11							
500-709-11*		Blade	with thumb roller			Carbide-tipped jaws for outside measurement	
500-719-10			—			Carbide-tipped jaws for outside and inside measurement	
500-721-10			with thumb roller			—	
500-723-10			—				
500-727-11			with thumb roller				
500-703-10*			0 - 200mm				
500-713-10	—						
500-707-11*	with thumb roller			Carbide-tipped jaws for outside measurement			
500-717-11	—	Carbide-tipped jaws for outside and inside measurement					
500-722-10	with thumb roller						
500-724-10	—						
500-728-11	0 - 300mm	with thumb roller	—				
500-714-10		—					
500-718-11		with thumb roller					
500-704-10*		—					
500-708-11*		—					

* without SPC data output

Inch/Metric								
Order No.	Range	Depth bar	Fine adjustment	Remarks				
500-752-10*	0 - 6"	Blade	—					
500-762-10						.075" rod		
500-768-10*		Blade					with thumb roller	Carbide-tipped jaws for outside measurement
500-769-10						—	Carbide-tipped jaws for outside and inside measurement	
500-731-10*						with thumb roller	Carbide-tipped jaws outside and inside measurement	
500-735-10						—	—	
500-733-10*						0 - 8"	with thumb roller	Carbide-tipped jaws for outside measurement
500-737-10							—	Carbide-tipped jaws for outside and inside measurement
500-753-10*							with thumb roller	Carbide-tipped jaws for outside measurement
500-763-10							—	Carbide-tipped jaws for outside and inside measurement
500-732-10*	0 - 12"	with thumb roller	—					
500-736-10		—						
500-734-10*	with thumb roller	—						
500-738-10	—							
500-764-10	with thumb roller	—						
500-754-10*	—							

* without SPC data output

DIMENSIONS

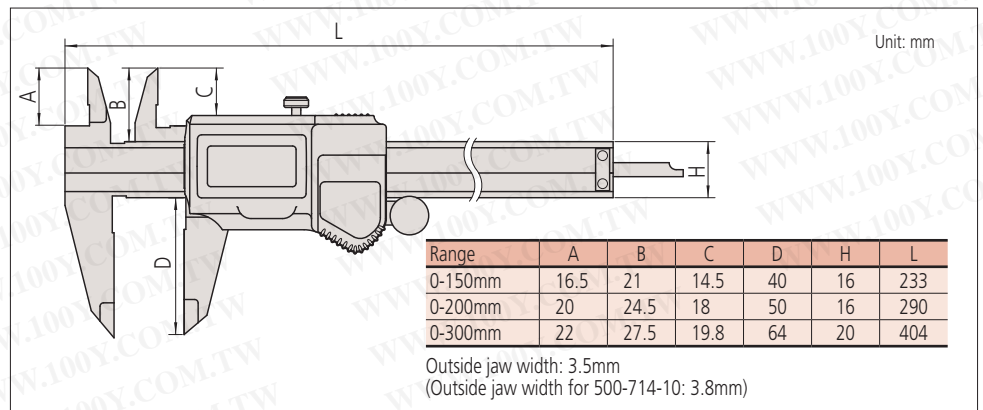

Calipers

An industry standard in measuring tools

ABSOLUTE Digimatic Caliper 500 Series — with exclusive ABSOLUTE Encoder Technology

- Electromagnetic induction system allows use in workshop conditions exposed to coolant, water, dust oil.
- New ergonomic design with finger rest.
- The ZERO/ABS button allows the display to be Zero-Set at any slider position along the scale for comparison measurements. This button will also allow return to the absolute (ABS) mode and display of the true position (from the origin (usually jaws closed point)).
- Large and clear LCD readout.
- Smooth slider movement makes for comfortable operation.
- 18,000 hours battery life.
- Allows step measurement.
- Carbide-tipped jaw calipers are optimal for rough finished parts, castings, grinding stones, etc.
- Allows integration into statistical process control and measurement systems for models with measurement data output connector. Refer to page A-3.

High quality guide surface finish for smooth slider movement

Conventional ex. No.500-151

ABSOLUTE Digimatic Caliper ex. No.500-151-30



500-151-30



500-182-30

A built-in ABS (absolute) scale means that these calipers are ready to use immediately after power-on without origin resetting – just like using a vernier caliper.

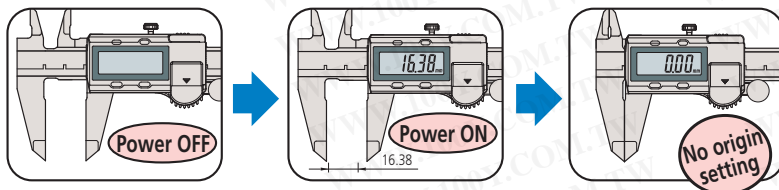

Optional accessories

Dedicated for the models equipped with a digimatic output function. For details, refer to page A-21.

959143: Data hold unit

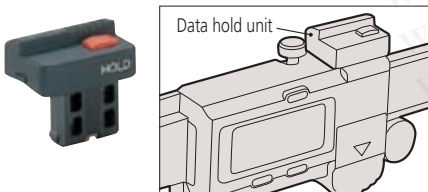

Connecting cables for IT/DP/MUX*

- 959149: SPC cable with data button (1m)
- 959150: SPC cable with data button (2m)



USB Input Tool Direct

- 06ADV380C: SPC cable for USB-ITN-C (2m)

Connecting cables for U-WAVE-T

- 02AZD790C: SPC cable for U-WAVE with data button (160mm)
- 02AZE140C: SPC cable for footswitch

ABSOLUTE™ (Refer to page IX for details.)



An inspection certificate is supplied as standard. Refer to page IX for details.

Technical Data

- Accuracy: $\pm 0.02\text{mm}$ ($\leq 200\text{mm}$), $\pm 0.03\text{mm}$ ($\leq 300\text{mm}$) (excluding quantizing error)
- Resolution: 0.01mm or .0005"/0.01mm
- Repeatability: 0.01mm
- Display: LCD
- Scale type*: ABSOLUTE electromagnetic induction linear encoder
- Max. response speed: Unlimited
- Battery: **SR44** (1 pc), **938882**, for initial operational checks (standard accessory)
- Battery life: Approx. 3.5 years under normal use (18,000 hours for continuous use)

Functions

Absolute measurement: After power is turned ON, measurement can be started without zero-setting if origin-setting was previously performed. The Absolute origin position can be changed by the ORIGIN button.

Incremental measurement: Display can be set to zero at any arbitrary position for comparative measurements

Low-voltage alert: If the battery voltage becomes low, a "B" appears in the display to alert the user before measurement is no longer possible. A battery change advisory alert precedes this alert.

Data output: By using the connecting cable (option), measurement data can be output.

Data hold: By using the data hold unit (option), the displayed value can be held. This cannot be used with the data output function.

SPECIFICATIONS

Metric					
Order No.	Range	Depth bar	Fine adjustment	Remarks	
500-150-30	0 - 100mm	ø1.9mm rod	with thumb roller	—	
500-180-30*			—		
500-151-30	0 - 150mm	Blade	with thumb roller	Carbide-tipped jaws for outside measurement	
500-155-30				Carbide-tipped jaws for outside and inside measurement	
500-158-30				—	
500-181-30*	0 - 200mm	Blade	with thumb roller	Carbide-tipped jaws for outside measurement	
500-152-30				Carbide-tipped jaws for outside and inside measurement	
500-156-30				—	
500-157-30				—	
500-182-30*	0 - 300mm	—	with thumb roller	—	
500-153				—	

* without SPC data output

Inch/Metric					
Order No.	Range	Depth bar	Fine adjustment	Remarks	
500-170-30	0 - 4"	.075" rod	with thumb roller	—	
500-195-30*				—	
500-171-30	0 - 6"	Blade	with thumb roller	Carbide-tipped jaws for outside measurement	
500-174-30				Carbide-tipped jaws for outside and inside measurement	
500-175-30				—	
500-178-30	0 - 8"	.075" rod	with thumb roller	Carbide-tipped jaws for outside measurement	
500-196-30*				Carbide-tipped jaws for outside and inside measurement	
500-159-30*				—	
500-160-30*				—	
500-172-30	0 - 12"	Blade	with thumb roller	Carbide-tipped jaws for outside measurement	
500-176-30				Carbide-tipped jaws for outside and inside measurement	
500-177-30				—	
500-197-30*				Carbide-tipped jaws for outside measurement	
500-163-30*				Carbide-tipped jaws for outside and inside measurement	
500-164-30*	—				
500-173	0 - 12"	—	—	Carbide-tipped jaws for outside measurement	
500-167				Carbide-tipped jaws for outside and inside measurement	
500-168				—	
500-193*				Carbide-tipped jaws for outside measurement	
500-165*				Carbide-tipped jaws for outside and inside measurement	
500-166*	—				

* without SPC data output

DIMENSIONS

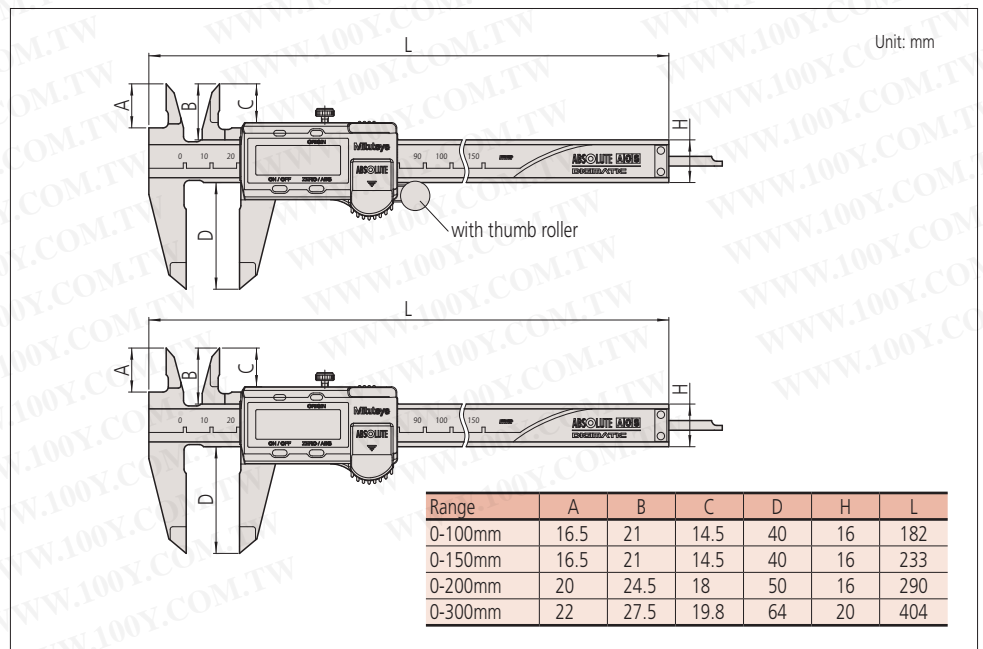

Calipers

An industry standard in measuring tools

ABSOLUTE™ (Refer to page IX for details.)

Long ABSOLUTE Digimatic Caliper 500 Series — with Exclusive ABSOLUTE Encoder Technology

- Long Digital caliper incorporating an ABSOLUTE scale and available with a measuring range from 450mm to 1000mm.
- Allows step measurement
- Allows integration into statistical process control and measurement systems for models with measurement data output connector. Refer to page A-3.
- For the details of the Absolute scale and its function, refer to page D-8.



SPECIFICATIONS

Metric				
Order No.	Range	Depth bar	Fine adjustment	Remarks
500-500-10	0 - 450mm	—	—	—
500-501-10	0 - 600mm	—	—	—
500-502-10	0 - 1000mm	—	—	—

* without SPC data output

Inch/Metric				
Order No.	Range	Depth bar	Fine adjustment	Remarks
500-505-10	0 - 18"	—	—	—
500-506-10	0 - 24"	—	—	—
500-507-10	0 - 40"	—	—	—

* without SPC data output

Technical Data

Accuracy: $\pm 0.05\text{mm}$ ($\leq 600\text{mm}$), $\pm 0.07\text{mm}$ ($\leq 1000\text{mm}$)
(excluding quantizing error)
Resolution: 0.01mm or .0005"/0.01mm
Repeatability: 0.01mm
Display: LCD
Scale type: ABSOLUTE electrostatic capacity linear encoder
Max. response speed: Unlimited
Battery: **SR44** (1 pc), **938882**,
for initial operational checks (standard accessory)
Battery life: Approx. 3.5 years under normal use
Max. response speed: Unlimited

DIMENSIONS

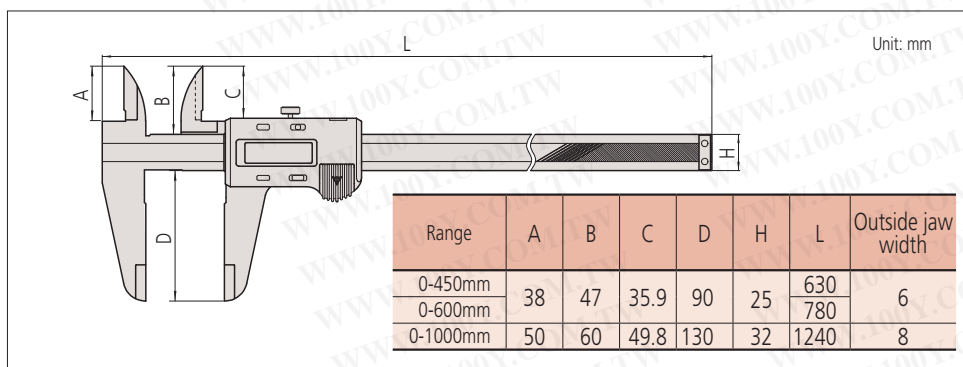

Optional accessories

Dedicated for the models equipped with a digimatic output function. For details, refer to page A-21.

959143: Data hold unit

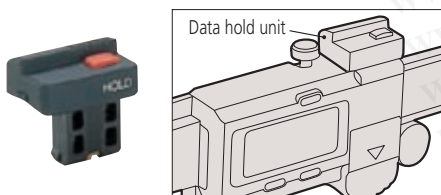

Connecting cables for IT/DP/MUX*

- 959149: SPC cable with data button (1m)
- 959150: SPC cable with data button (2m)



USB Input Tool Direct

- 06ADV380C: SPC cable for USB-ITN-C (2m)

Connecting cables for U-WAVE-T

- 02AZD790C: SPC cable for U-WAVE with data button (160mm)
- 02AZE140C: SPC cable for footswitch



An inspection certificate is supplied as standard. Refer to page IX for details.

Technical Data

Accuracy: ±0.02mm (excluding quantizing error)
 Resolution: 0.01mm or .0005"/0.01mm
 Repeatability: 0.01mm
 Display: LCD
 Scale type: ABSOLUTE electrostatic capacity linear encoder
 Power supply: Solar cell*
 Max. response speed: Unlimited
 Operational temperature: 0 to 40°C
 * Can be used continuously above 60lux ambient illumination

Functions

Absolute measurement
 Scale contamination detection
 Data output (use together with optional connecting cable)
 Data hold (use optional hold unit. This cannot be used with the data output function)
 * For details of the function, refer to page D-8.

ABSOLUTE Solar Caliper SERIES 500 — No battery or origin reset needed

- Mitutoyo's Absolute Solar Digimatic Caliper retains its origin point indefinitely.
- At 60 Lux and above the ABSOLUTE solar caliper is ready to start measurement. No more repeated zero setting caused by a shortage of light.
- An ABSOLUTE scale is incorporated so that zero setting is not required at each power ON. No danger of overspeed errors.
- Slider operation is smooth and comfortable.
- Allows step measurement.
- Allows integration into statistical process control and measurement systems for models with measurement data output connector. Refer to page A-3.

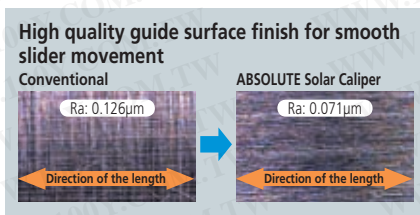

500-444

SPECIFICATIONS

Metric			
Order No.	Range	Depth bar	Fine adjustment
500-443	0 - 100mm	∅1.9mm rod	with thumb roller
500-453*	0 - 150mm	Blade	
500-444			
500-454*	0 - 200mm	Blade	
500-445			
500-455*			

* without SPC data output

Inch/Metric			
Order No.	Range	Depth bar	Fine adjustment
500-463	0 - 4"	.075" rod	with thumb roller
500-473*	0 - 6"	Blade	
500-464			
500-474*	0 - 8"	Blade	
500-465			
500-475*			

* without SPC data output

DIMENSIONS

Range	A	B	C	D	H	L
0-100mm	16.5	21	14.5	40	16	182
0-150mm						233
0-200mm	20	24.5	18	50		290

Optional accessories

Dedicated for the models equipped with a digimatic output function. For details, refer to page A-21.

959143: Data hold unit



Connecting cables for IT/DP/MUX*

- 959149: SPC cable with data button (1m)
- 959150: SPC cable with data button (2m)



USB Input Tool Direct

- 06ADV380C: SPC cable for USB-ITN-C (2m)

Connecting cables for U-WAVE-T

- 02AZD790C: SPC cable for U-WAVE with data button (160mm)
- 02AZE140C: SPC cable for footswitch

Calipers

An industry standard in measuring tools

Vernier Caliper 530 Series — Standard model

- Plain and basic design.
- Stepped graduation face prevents dust ingress between the main scale and slider.
- The small vernier face angle (14°) provides easy reading.
- Can measure outside and inside dimensions, depth, and steps.
- Carbide-tipped jaw calipers are optimal for rough finished parts, castings, grinding stones, etc.
- Decimal and fractional graduated scales (metric/inch and inch models only).

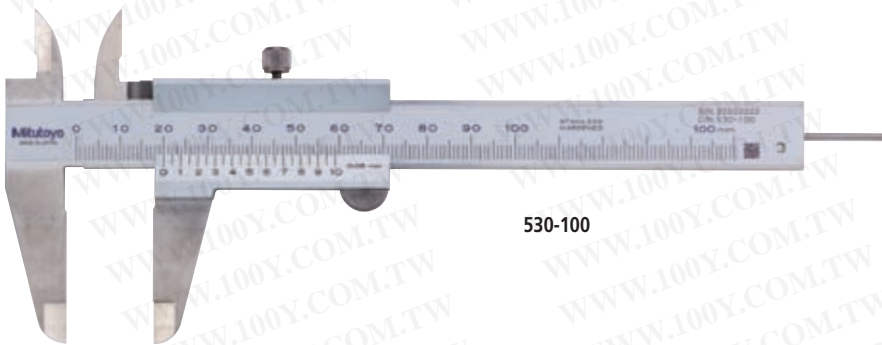
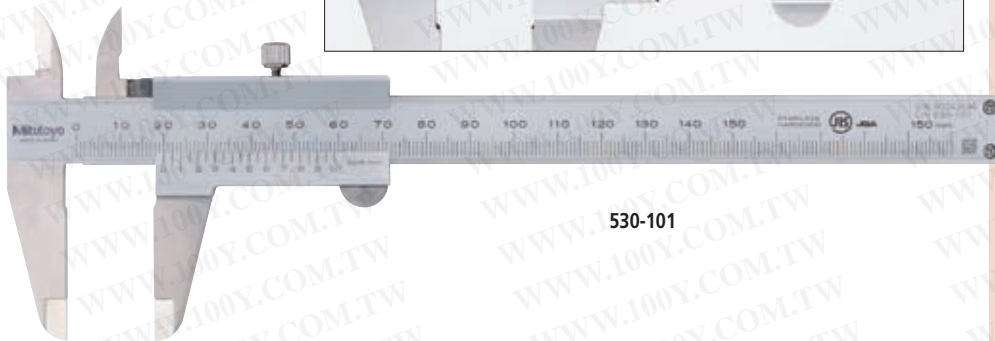
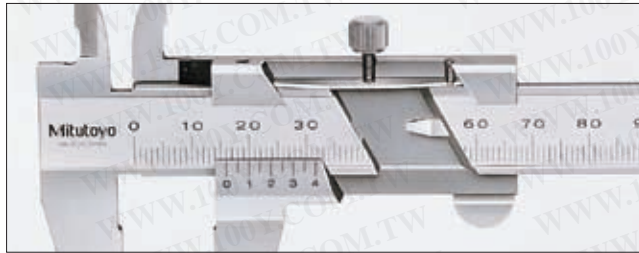
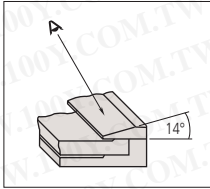

530-102 (Round depth bar type)



530-320 (Carbide-tipped jaw type)

DIMENSIONS

Unit: mm

Range	Outside jaw width
0 - 100mm	3
0 - 150mm	
0 - 200mm	3.8
0 - 300mm	
0 - 600mm	6
0 - 1000mm	8

Range	A	B	D	E	F	H	L
0 - 100mm	17	21.5	40	53.5	30	16	182
0 - 150mm	17	21.5	40	53.5	30	16	229
0 - 200mm	20.5	25	50	53.5	30	16	288
0 - 300mm	22	27.5	64	66.5	36	20	404
0 - 600mm	38	47	90	89	50	25	780
0 - 1000mm	50	60	130	111	61	32	1240

* Code No.530-100 and No.530-102 incorporate a round depth bar (ø1.9mm).
The depth bar shown in the illustration above is a different type.

Technical Data

Accuracy: $\pm 0.05\text{mm}$ ($\leq 200\text{mm}$), $\pm 0.08\text{mm}$ ($\leq 300\text{mm}$)
 $\pm 0.10\text{mm}$ ($\leq 600\text{mm}$), $\pm 0.15\text{mm}$ ($\leq 1000\text{mm}$)
 High accuracy type:
 $\pm 0.03\text{mm}$ ($\leq 200\text{mm}$), $\pm 0.04\text{mm}$ ($\leq 300\text{mm}$)
 Graduation: 0.05mm , 0.05mm ($1/128''$) or $.001''$ ($1/128''$)
 High accuracy type:
 0.02mm or 0.02mm ($.001''$)

SPECIFICATIONS

Metric				
Order No.	Range	Depth bar	Remarks	
530-100	0 - 100mm	ø1.9mm rod	—	
530-102			—	
530-101			—	
530-320	0 - 150mm	Blade	Carbide-tipped jaws for outside measurement	
530-335			Carbide-tipped jaws for outside and inside measurement	
530-122*			High accuracy model: $\pm 0.03\text{mm}$	
530-108	—			
530-321	0 - 200mm		Carbide-tipped jaws for outside measurement	
530-123*		High accuracy model: $\pm 0.03\text{mm}$		
530-109	0 - 300mm	—		
530-322		Carbide-tipped jaws for outside measurement		
530-124*		High accuracy model: $\pm 0.04\text{mm}$		
530-501	0 - 600mm	—	—	
530-502	0 - 1000mm	—	—	

* Graduation: 0.02mm

Metric/Inch with metric/inch double scale				
Order No.	Range	Depth bar	Inch graduation	Remarks
530-104	0 - 150mm	Blade	1/128"	—
530-316			1/128"	Clamping screw below the slider
530-312*			.001"	High accuracy model: $\pm 0.03\text{mm}$
530-114	0 - 200mm		1/128"	—
530-118*			.001"	High accuracy model: $\pm 0.03\text{mm}$
530-115	0 - 300mm	1/128"	—	
530-119*		.001"	High accuracy model: $\pm 0.04\text{mm}$	

* Graduation: 0.02mm

Inch with inch/inch double scale				
Order No.	Range	Depth bar	Inch graduation	Remarks
530-105	0 - 6"	Blade	1/128"	—
530-116	0 - 8"			

Measurement Applications

1. Outside measurement



2. Inside measurement

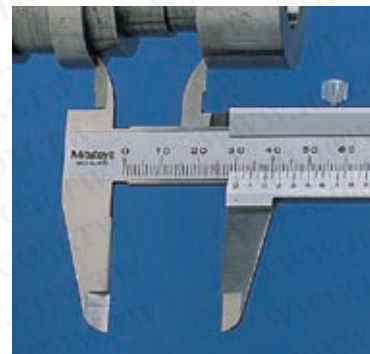

3. Step measurement



4. Depth measurement

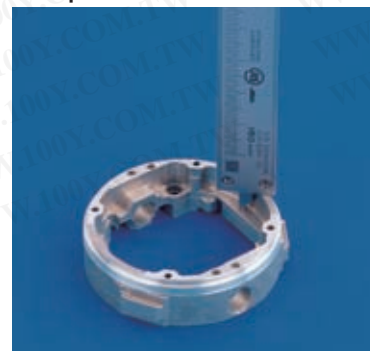

Calipers

An industry standard in measuring tools

Vernier Caliper 532 Series — with fine adjustment

- Fine-adjustment aids slider positioning.
- Allows step measurement.

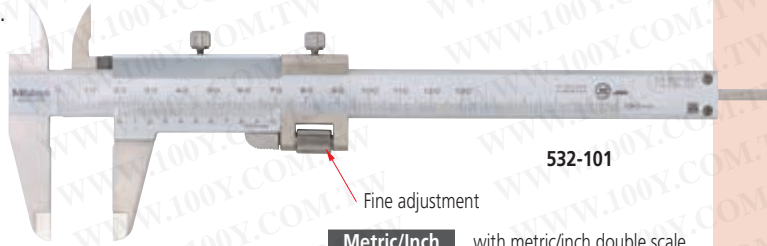

Technical Data

Accuracy: $\pm 0.03\text{mm}$ ($\leq 180\text{mm}$), $\pm 0.04\text{mm}$ ($\leq 280\text{mm}$)
 Graduation: 0.02mm, 0.02mm (.001") or .001" (1/128")

SPECIFICATIONS

Metric			
Order No.	Range	Depth bar	Remarks
532-101	0 - 130mm	Blade	with fine adjustment
532-102	0 - 180mm		
532-103	0 - 280mm		

Metric/Inch with metric/inch double scale				
Order No.	Range	Depth bar	Inch graduation	Remarks
532-119	0 - 130mm	Blade	.001"	with fine adjustment
532-120	0 - 180mm			
532-121	0 - 280mm			

DIMENSIONS

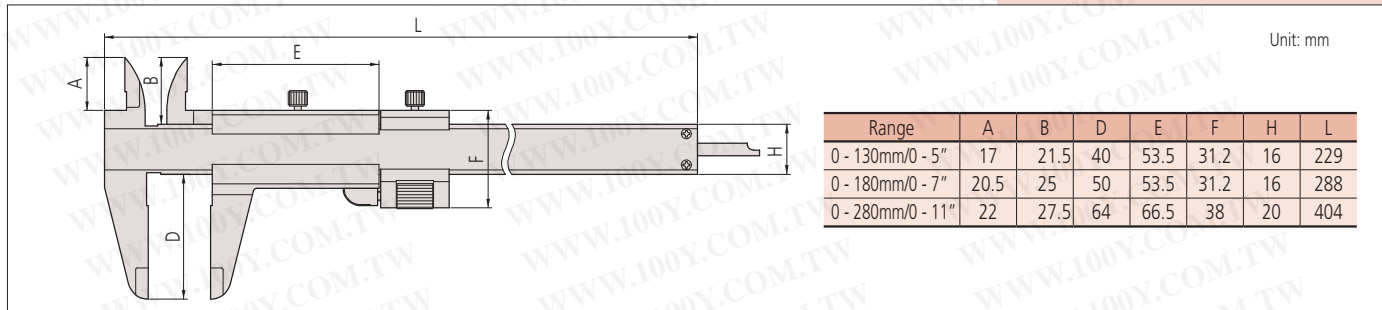

Vernier Caliper 531 Series — with thumb clamp

- The slider moves only when the spring-loaded thumb grip is depressed.
- Allows step measurement.

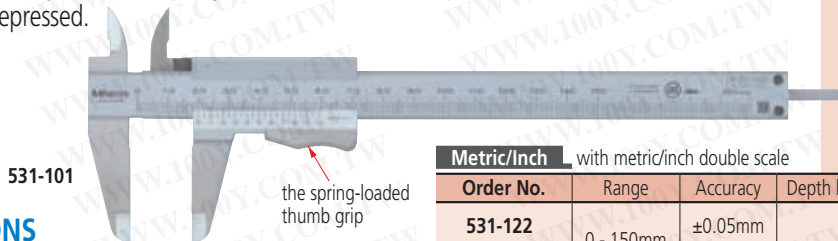

Technical Data

Accuracy: Refer to the list of specifications.
 Graduation: 0.05mm, 0.05mm (1/128") or .001" (1/128")
 High accuracy type:
 0.02mm or 0.02mm (.001")

SPECIFICATIONS

Metric				
Order No.	Range	Accuracy	Depth bar	Remarks
531-101	0 - 150mm	$\pm 0.05\text{mm}$	Blade	—
531-102	0 - 200mm	$\pm 0.05\text{mm}$		
531-103	0 - 300mm	$\pm 0.08\text{mm}$		

Metric/Inch with metric/inch double scale					
Order No.	Range	Accuracy	Depth bar	Inch graduation	Remarks
531-122	0 - 150mm	$\pm 0.05\text{mm}$	Blade	1/128"	with inch/mm conversion label
531-128*		$\pm 0.03\text{mm}$.001"	High accuracy model
531-108	0 - 200mm	$\pm 0.05\text{mm}$		1/128"	—
531-129*		$\pm 0.03\text{mm}$.001"	High accuracy model
531-109	0 - 300mm	$\pm 0.08\text{mm}$		1/128"	—
531-112*		$\pm 0.04\text{mm}$.001"	High accuracy model

* Graduation: 0.02mm

* Graduation: 0.02mm

DIMENSIONS

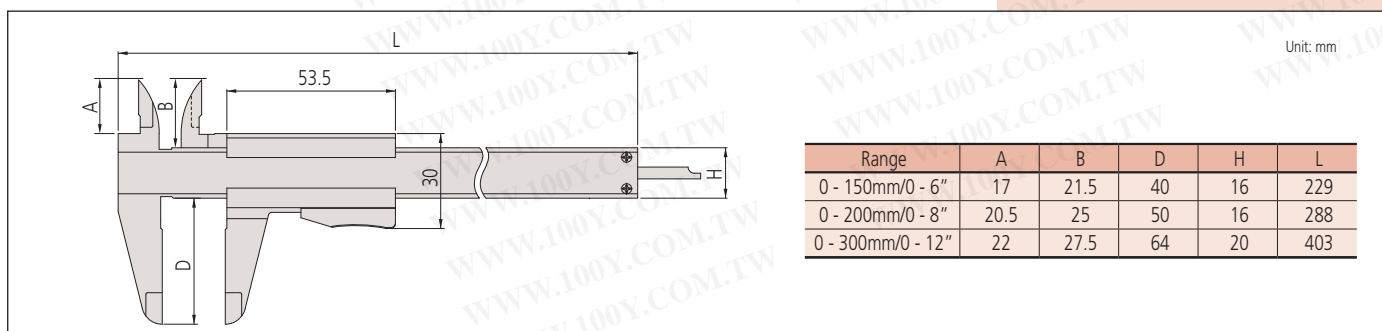

Technical Data

Accuracy: Refer to the list of specifications.
 Graduation: 0.05mm (1/128")
 High accuracy type: 0.02mm (.001")

Vernier Caliper SERIES 522 — Parallax-Free Type

- The main and vernier scales are flush-fitted to eliminate parallax errors because of the diamond-shape (octagonal) cross section of the main scale.
- Can measure outside and inside diameter (OD and ID), depth, and steps.
- With locking screw below the slider.

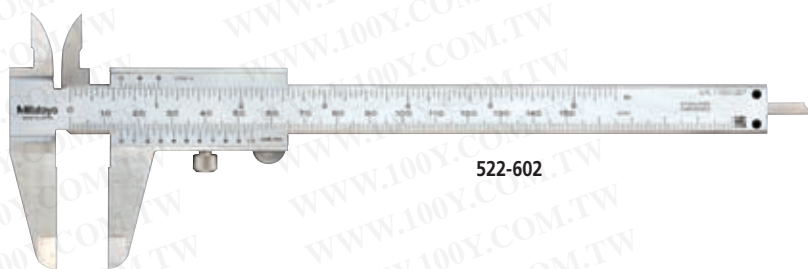

SPECIFICATIONS

Metric				
Order No.	Range	Accuracy	Depth bar	Remarks
522-606*	0 - 150mm	±0.03mm	Blade	High accuracy model

* Graduation: 0.02mm

Metric/Inch with metric/inch double scale					
Order No.	Range	Accuracy	Depth bar	Inch resolution	Remarks
522-601	0 - 150mm	±0.05mm	Blade	1/128"	—
522-602*		±0.03mm		.001"	High accuracy model

* Graduation: 0.02mm

DIMENSIONS

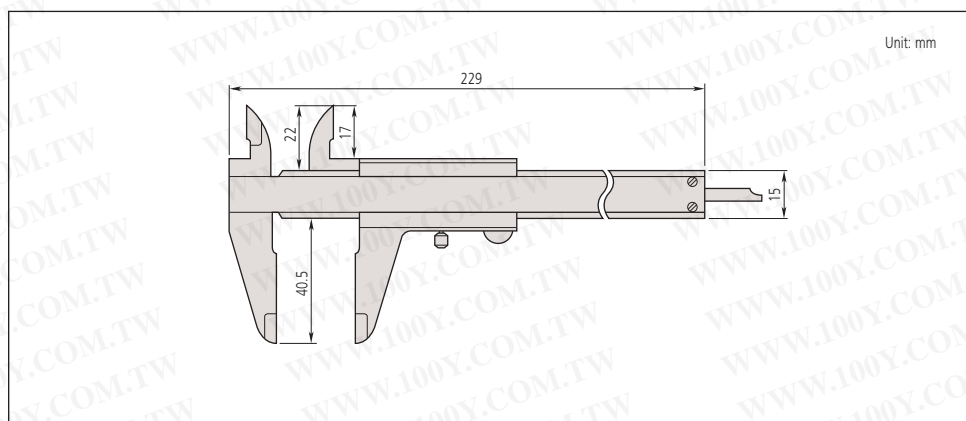

Calipers

An industry standard in measuring tools

ABSOLUTE Digimatic Caliper 550 Series — with Nib Style Jaws

- Offers a resolution of 0.01mm with corresponding accuracy.
- Incorporates an Absolute measurement system. No need to reset the origin after switching on. (Refer to page D-8 for a description of Absolute measurement.)
- Code Nos. 550-301-10, 550-331-10, 550-311-10 and 550-341-10: IP67 (These models are not a waterproof type. Therefore a rustproofing shall be applied after use.)
- Allows integration into statistical process control and measurement systems for models with measurement data output connector. Refer to page A-3.
- ID measurement value: displayed value + (the minimum inside measurement value mentioned below). OFFSET switch allows to input a compensation value so that the measurement value can be read directly (Code Nos. 550-301-10, 550-331-10, 550-311-10 and 550-341-10). Preset function allows to set a desired starting point (Code Nos. 550-331-10 and 550-341-10).



550-301-10

SPECIFICATIONS

Metric

Order No.	Range*	Accuracy	Remarks
550-301-10	0 - 200mm (10 - 210mm)	±0.03mm	IP67
550-331-10	0 - 300mm (10 - 310mm)	±0.04mm	IP67, with offset/preset function for easy inside measurement
550-203-10	0 - 450mm (20 - 470mm)	±0.05mm	—
550-205-10	0 - 600mm (20 - 620mm)	±0.05mm	—
550-207-10	0 - 1000mm (20 - 1020mm)	±0.07mm	—

* () : Inside measurement

Note: Series 550 is not equipped with a depth bar.

Inch/Metric

Order No.	Range*	Accuracy	Remarks
550-311-10	0 - 8" (.4" - 8.4")	±.0015"	IP67
550-341-10	0 - 12" (.4" - 12.4")	±.002"	IP67, with offset/preset function for easy inside measurement
550-223-10	0 - 18" (.5" - 18.5")		—
550-225-10	0 - 24" (.5" - 24.5")		—
550-227-10	0 - 40" (1" - 41")	±.003"	—

* () : Inside measurement

Note: Series 550 is not equipped with a depth bar.

DIMENSIONS

Range	D	J	S	R
0 - 200mm	60	40.5	8	5
0 - 300mm	75	50.5	12	5
0 - 450mm	100	65	18	10
0 - 600mm	100	65	18	10
0 - 1000mm	140	95	24	10

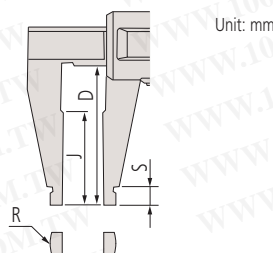

ABSOLUTE™ (Refer to page IX for details.)



(Refer to page IX for details.)



(Refer to page IX for details.)

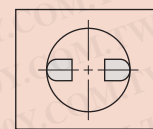
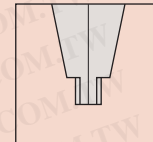

Radiused jaws for accurate ID measurement

Technical Data

Accuracy: Refer to the list of specifications. (excluding quantizing error for digital models)

Resolution: 0.01mm or .0005"/0.01mm

Display: LCD

Scale type: ABSOLUTE electromagnetic induction linear encoder

Max. response speed: Unlimited

Battery: **SR44** (1 pc), **938882**, for initial operational checks (standard accessory)

Battery life: Approx. 3 years under normal use (1 year: 300mm models) (3.5 years: over 300mm models)

Dust/Water protection level: IP67* (models up to 300mm)

*This model is not waterproof type.

Therefore, rustproofing shall be applied after use.

Optional accessories

For details, refer to page A-21.

959143: Data hold unit

Connecting cables for IT/DP/MUX

05CZA624: SPC cable with data button (1m)*

05CZA625: SPC cable with data button (2m)*



959149: SPC cable with data button (1m)

959150: SPC cable with data button (2m)

USB Input Tool Direct

06ADV380A: SPC cable for USB-ITN-A (2m)*

06ADV380C: SPC cable for USB-ITN-C(2m)

Connecting cables for U-WAVE-T

02AZD790A: SPC cable for U-WAVE with data button (160mm)*

02AZE140A: SPC cable for footswitch*

02AZD790C: SPC cable for U-WAVE with data button (160mm)

02AZE140C: SPC cable for footswitch

* For IP67 models (up to 300mm)

ABSOLUTE™ (Refer to page IX for details.)

IP67

(Refer to page IX for details.)



(Refer to page IX for details.)

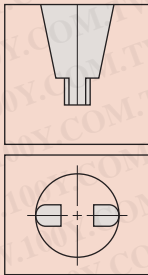

Radiused jaws for accurate ID measurement

Technical Data

Accuracy: Refer to the list of specifications.
(excluding quantizing error for digital models)

Resolution: 0.01mm or .0005"/0.01mm

Display: LCD

Scale type: ABSOLUTE electromagnetic induction linear encoder

Max. response speed: Unlimited

Battery: **SR44** (1 pc), **938882**,
for initial operational checks (standard accessory)

Battery life: Approx. 3 years under normal use
(1 year: 300mm models)
(3.5 years: over 300mm models)

Dust/Water protection level: IP67* (models up to 300mm)

*This model is not waterproof type.
Therefore, rustproofing shall be applied after use.

Optional accessories

For details, refer to page A-21.

959143: Data hold unit

Connecting cables for IT/DP/MUX

05CZA624: SPC cable with data button (1m)*

05CZA625: SPC cable with data button (2m)*



959149: SPC cable with data button (1m)

959150: SPC cable with data button (2m)

USB Input Tool Direct

06ADV380A: SPC cable for USB-ITN-A (2m)*

06ADV380C: SPC cable for USB-ITN-C (2m)

Connecting cables for U-WAVE-T

02AZD790A: SPC cable for U-WAVE with data button
(160mm)*

02AZE140A: SPC cable for footswitch*

02AZD790C: SPC cable for U-WAVE with data button
(160mm)

02AZE140C: SPC cable for footswitch

* For IP67 models (up to 300mm)

ABSOLUTE Digimatic Caliper 551 Series - with Nib Style and Standard Jaws

- Offers a resolution of 0.01mm with corresponding accuracy.
- Incorporates an Absolute measurement system. No need to reset the origin after switching on. (Refer to page D-8 for a description of Absolute measurement.)
- Allows integration into statistical process control and measurement systems for models with measurement data output connector. Refer to page A-3.
- ID measurement value: displayed value + (the minimum inside measurement value mentioned below). OFFSET switch allows to input a compensation value so that the measurement value can be read directly (Code No. 551-301-10, 551-331-10, 551-311-10 and 551-341-10). Preset function allows to set a desired starting point (Code No. 551-331-10 and 551-341-10).
- Tips of the outside measurement jaw are relieved for easy measurement of thin parts.

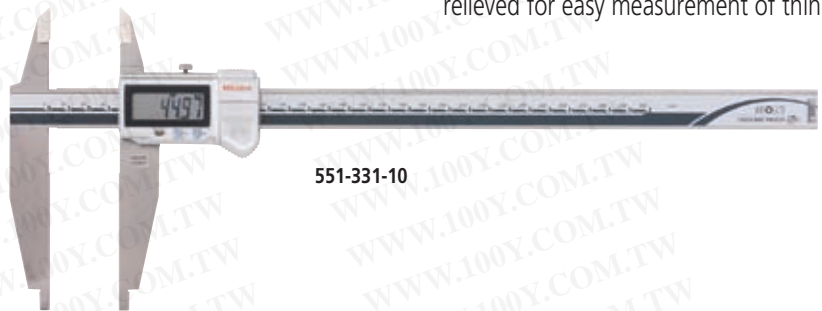

SPECIFICATIONS

Metric			
Order No.	Range*	Accuracy	Remarks
551-301-10	0 - 200mm (10 - 210mm)	±0.03mm	IP67
551-331-10	0 - 300mm (10 - 310mm)	±0.04mm	IP67, with offset/preset function for easy inside measurement
551-204-10	0 - 500mm (20 - 520mm)	±0.06mm	—
551-206-10	0 - 750mm (20 - 770mm)	±0.06mm	
551-207-10	0 - 1000mm (20 - 1020mm)	±0.07mm	

* () : inside measurement

Note: Series 551 is not equipped with a depth bar.

Inch/Metric			
Order No.	Range*	Accuracy	Remarks
551-311-10	0 - 8" (.4" - 8.4")	±.0015"	IP67
551-341-10	0 - 12" (.4" - 12.4")	±.002"	IP67, with offset/preset function for easy inside measurement
551-224-10	0 - 20" (.5" - 20.5")	±.0025"	—
551-226-10	0 - 30" (.5" - 30.5")	±.0025"	
551-227-10	0 - 40" (1" - 41")	±.003"	

* () : inside measurement

Note: Series 551 is not equipped with a depth bar.

DIMENSIONS

Range	A	D	J	S
0 - 200mm	30	60	43	8
0 - 300mm	40.1	90	68	10
0 - 500mm	56	150	115	15
0 - 750mm	56	150	115	15
0 - 1000mm	56	150	115	20

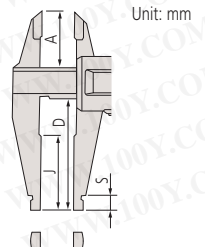

Unit: mm

Calipers

An industry standard in measuring tools

Dial Caliper Series 505

- Newly designed dial movement for ultra-smooth sliding and high shock protection.
- Titanium coating is applied to the sliding surfaces to enhance the durability (except for 0 - 300mm and 0 - 12" model).
- Easy-to-read yellow dial.
- Large finger-rest aids ease-of-use.
- Jaw tips are relieved for easy measurement of thin parts.
- Allows step measurement.

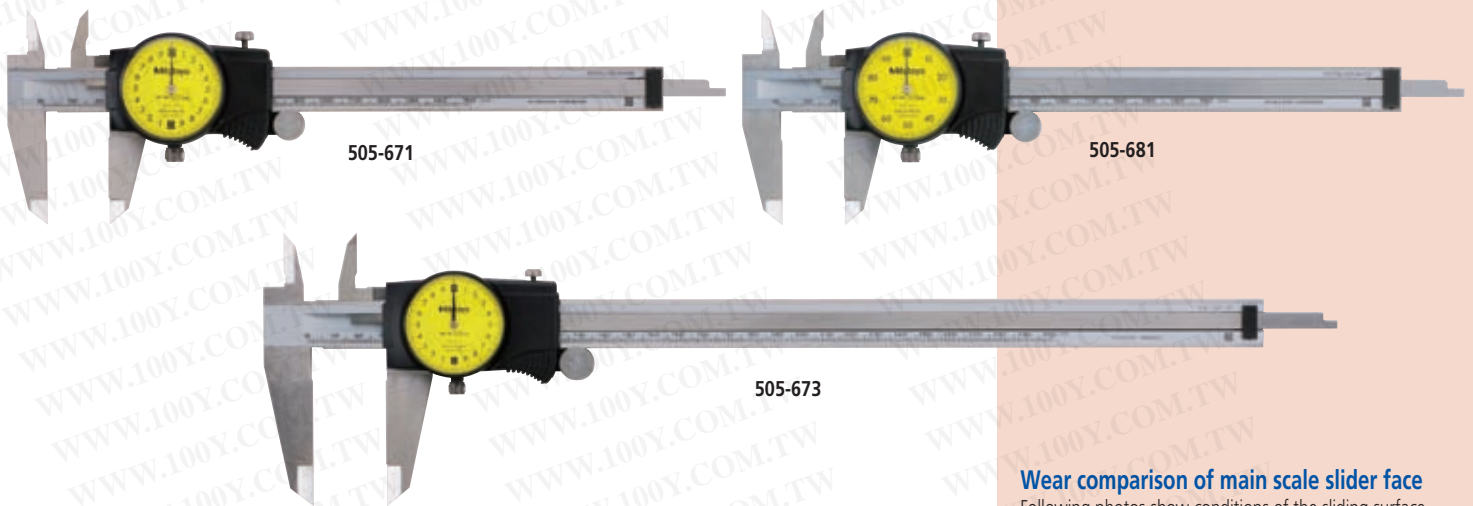

An inspection certificate is supplied as standard. Refer to page IX for details.

SPECIFICATIONS

Metric				
Order No.	Range	Accuracy	Graduation	Remarks
505-680	0 - 100mm	±0.015mm	0.01mm, 1mm/rev	—
505-671 / 505-683*	0 - 150mm	±0.03mm	0.02mm, 2mm/rev	—
505-707				Carbide-tipped jaws for outside measurement
505-711				Carbide-tipped jaws for outside and inside measurement
505-681 / 505-685*	0 - 200mm	±0.02mm	0.01mm, 1mm/rev	—
505-672 / 505-684*				0.02mm, 2mm/rev
505-682 / 505-686*				0.01mm, 1mm/rev
505-673	0 - 300mm	±0.04mm	0.02mm, 2mm/rev	—

* Silver cover type

Inch				
Order No.	Range	Accuracy	Graduation	Remarks
505-674	0 - 4"	±.001"	.001", .1"/rev	—
505-675 / 505-689*	0 - 6"	±.001"		Carbide-tipped jaws for outside measurement
505-708		±.001"		Carbide-tipped jaws for outside and inside measurement
505-712	0 - 8"	±.002"	.001", .2"/rev	—
505-676 / 505-690*		±.002"		Carbide-tipped jaws for outside measurement
505-709		±.002"		Carbide-tipped jaws for outside and inside measurement
505-713	0 - 12"	±.002"	.001", .1"/rev	—
505-720		±.002"		Carbide-tipped jaws for outside measurement
505-677*		±.002"		Carbide-tipped jaws for outside and inside measurement
505-721		±.002"		Carbide-tipped jaws for outside measurement
505-710*		±.002"		Carbide-tipped jaws for outside and inside measurement
505-714*		±.002"	.001", .1"/rev	Carbide-tipped jaws for outside and inside measurement

* Silver cover type

Wear comparison of main scale slider face

Following photos show conditions of the sliding surface after a sliding test comprising 100,000 movements. Smooth movement over the entire measuring range is assured even when you use a particular part of the sliding surface repeatedly.

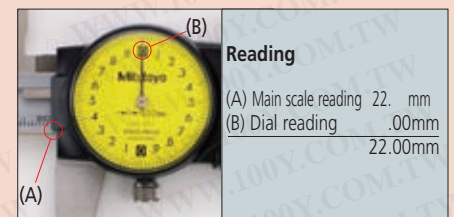
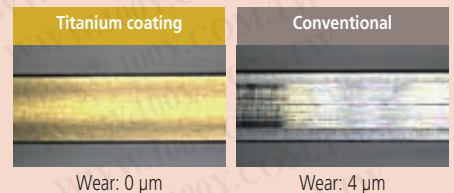

DIMENSIONS

Unit: mm

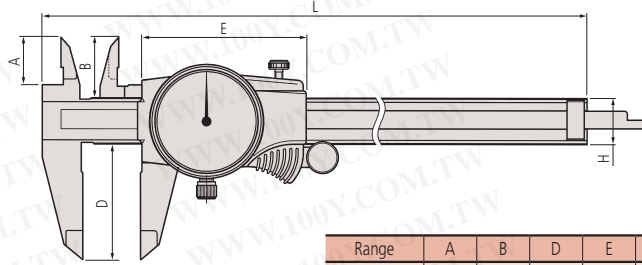

Range	A	B	D	E	H	L
0 - 100mm	16.5	21	40	57.2	16	180
0 - 150mm						231
0 - 200mm	20	24.5	50	70.2	20	288
0 - 300mm	22	27.5	64			404

Calipers

An industry standard in measuring tools

ABSOLUTE Coolant Proof Carbon Fiber Caliper SERIES 552 — with Interchangeable Jaws

- IP66 Absolute Digital Caliper (Refer to page D-8 for Absolute function.)
- Lightweight Digimatic Calipers that employ CFRP (Carbon Fiber Reinforced Plastics) in the beam and jaws.
- Allows integration into statistical process control and measurement systems for models with measurement data output connector. Refer to page A-3.



552-303-10

SPECIFICATIONS

Metric		
Order No. (standard / long jaws / ceramic jaws)	Range*	Accuracy (standard / long jaws / ceramic jaws)
552-302-10	0 (20) - 450mm	±0.04mm / ±0.06mm / ±0.04mm
552-303-10	0 (20) - 600mm	±0.04mm / ±0.06mm / ±0.04mm
552-304-10	0 (20) - 1000mm	±0.05mm / ±0.07mm
552-305-10	0 (20) - 1500mm	±0.09mm / ±0.11mm
552-306-10	0 (20) - 2000mm	±0.12mm / ±0.14mm

* () : Minimum dimension in inside measurement

Inch/Metric		
Order No. (standard / long jaws / ceramic jaws)	Range*	Accuracy (standard / long jaws / ceramic jaws)
552-312-10	0 (.5") - 18"	±.002" / ±.0025" / ±.002"
552-313-10	0 (.5") - 24"	±.002" / ±.0025" / ±.002"
552-314-10	0 (1") - 40"	±.002" / ±.003"
552-315-10	0 (1") - 60"	±.004" / ±.0045"
552-316-10	0 (1") - 80"	±.005" / ±.0055"

* () : Minimum dimension in inside measurement

DIMENSIONS

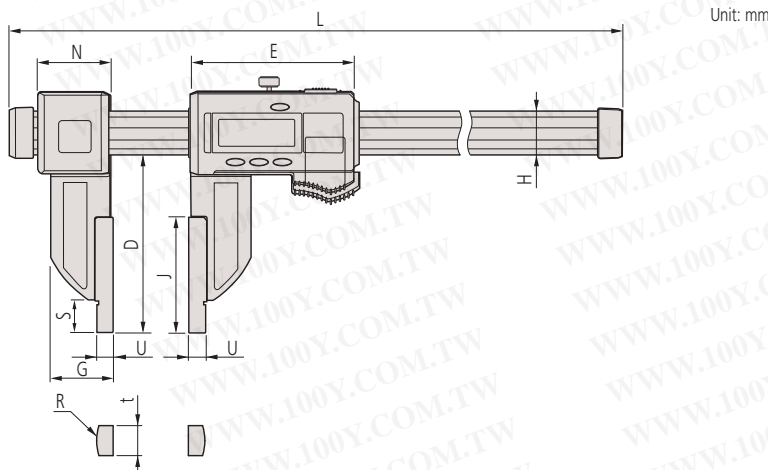

Unit: mm

Range	D	E	G	H	J	L	N	R	S	t	U
0-450mm (0-18")	100	91.8	35	25	65	640	41.2	R10	18	8	10 (.25")
0-600mm (0-24")	100	91.8	35	25	65	790	41.2	R10	18	8	10 (.25")
0-1000mm (0-40")	150	113.8	45	32	100	1230	62.8	R10	24	8	10 (.5")
0-1500mm (0-60")	150	113.8	45	32	100	1740	62.8	R10	24	8	10 (.5")
0-2000mm (0-80")	150	113.8	45	32	100	2250	62.8	R10	24	8	10 (.5")

ABSOLUTE™ (Refer to page IX for details.)



(Refer to page IX for details.)



(Refer to page IX for details.)

Technical Data

Accuracy: Refer to the list of specifications.
(excluding quantizing error)
Resolution: 0.01mm or .0005"/0.01mm
Display: LCD
Scale type: ABSOLUTE electromagnetic induction linear encoder
Max. response speed: Unlimited
Battery: **SR44** (1 pc), **938882**,
for initial operational checks (standard accessory)
Battery life: Approx. 5,000 hours in continuous use
Dust/Water protection level: IP66 (IEC60529)*
Standard accessory: Jaw clamps (2 pcs.), 05GZA033
* This model is not waterproof type. Please wipe away the wet after use.

Functions

Zero-setting
Data hold
Offsetting
Presetting
Data output
Low-power and low-voltage alert
Counting value composition error
Automatic power on/off, inch/mm reading
(inch/mm models)

Optional accessories

	No. 552-302-10, 552-155-10, 552-303-10, 552-156-10, 552-312-10, 552-165-10, 552-313-10 and 552-166-10	No. 552-304-10, 552-305-10, 552-306-10, 552-314-10, 552-315-10 and 552-316-10
Clamp box (1 pair)	No.914053	No.914054
Distance measurement jaw (1 pair)	No.914055	
Point ID measuring attachment	No.914057	

Optional accessories

For details, refer to page A-21.

Connecting cables for **IT/DP/MUX**

05CZA624: SPC cable with data button (1m)

05CZA625: SPC cable with data button (2m)



USB Input Tool Direct

06ADV380A: SPC cable for **USB-ITN-A** (2m)

Connecting cables for **U-WAVE-T**

02AZD790A: SPC cable for U-WAVE with data button (160mm)

02AZE140A: SPC cable for footswitch

	<p>Clamp box</p>
<p>Distant measurement jaw</p>	<p>Distance measurement jaw Accuracy: $\pm 0.03\text{mm}$</p>
<p>Point ID measuring attachment</p>	<p>Point ID measuring attachment Accuracy: $\pm 0.02\text{mm}$</p>

Calipers

An industry standard in measuring tools

ABSOLUTE Coolant Proof Carbon Fiber Caliper SERIES 552

- IP66 Absolute Digital Caliper (Refer to page D-8 for a description of Absolute measurement.)
- Lightweight Digimatic Calipers that employ CFRP (Carbon Fiber Reinforced Plastics) in the beam and jaws.
- Allows integration into statistical process control and measurement systems for models with measurement data output connector. Refer to page A-3.



552-151-10

SPECIFICATIONS

Metric		
Order No. (standard / long jaws / ceramic jaws)	Range*	Accuracy (standard / long jaws / ceramic jaws)
552-150-10	0 (20) - 450mm	±0.04mm / ±0.06mm / ±0.04mm
552-151-10	0 (20) - 600mm	
552-152-10	0 (20) - 1000mm	±0.05mm / ±0.07mm
552-153-10	0 (20) - 1500mm	±0.09mm / ±0.11mm
552-154-10	0 (20) - 2000mm	±0.12mm / ±0.14mm

* () : Minimum dimension in inside measurement

Inch/Metric		
Order No. (standard / long jaws / ceramic jaws)	Range*	Accuracy (standard / long jaws / ceramic jaws)
552-160-10	0 (.5") - 18"	±.002" / ±.0025" / ±.002"
552-161-10	0 (.5") - 24"	
552-162-10	0 (1") - 40"	±.002" / ±.003"
552-163-10	0 (1") - 60"	±.004" / ±.0045"
552-164-10	0 (1") - 80"	±.005" / ±.0055"

* () : Minimum dimension in inside measurement

DIMENSIONS

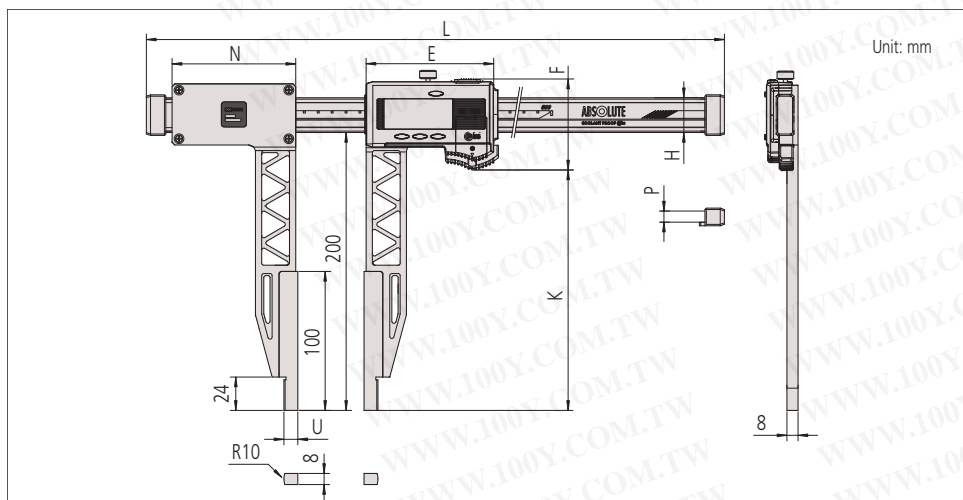

Range	E	F	H	K	L	N	P	U	
0 - 450mm (0-18")	91.8	65.5	25	173	680	89	8	10	
0 - 600mm (0-24")					830			(.25")	
0 - 1000mm (0-40")	113.8	73	32	170.5	1280	110	12	10	
0 - 1500mm (0-60")					1790				(,5")
0 - 2000mm (0-80")					2300				

() : Inch/Metric type

ABSOLUTE™ (Refer to page IX for details.)



(Refer to page IX for details.)



(Refer to page IX for details.)

Technical Data

Accuracy: Refer to the list of specifications.
(excluding quantizing error)
Resolution: 0.01mm or .0005"/0.01mm
Display: LCD
Scale type: ABSOLUTE electromagnetic induction linear encoder
Max. response speed: Unlimited
Battery: **SR44** (1 pc), **938882**, for initial operational checks (standard accessory)
Battery life: Approx. 5,000 hours in continuous use
Dust/Water protection level: IP66 (IEC 60529)*
Standard accessory: Jaw clamps (2 pcs.), 05GZA033
*This model is not waterproof type. Please wipe away the wet after use.

Functions

Zero-setting
Data hold
Offsetting
Presetting
Data output
Low-power and low-voltage alert
Counting value composition error
Automatic power on/off, inch/mm reading (inch/mm models)

Optional accessories

For details, refer to page A-21.
Connecting cables for **IT/DP/MUX***
05CZA624: SPC cable with data button (1m)
05CZA625: SPC cable with data button (2m)



USB Input Tool Direct

06ADV380A: SPC cable for **USB-ITN-A** (2m)
Connecting cables for **U-WAVE-T**
02AZD790A: SPC cable for U-WAVE with data button (160mm)
02AZE140A: SPC cable for footswitch

ABSOLUTE™ (Refer to page IX for details.)

IP66 (Refer to page IX for details.)

**TÜVRheinland
CERTIFIED**
www.tuv.com
ID 0000022582

(Refer to page IX for details.)

Technical Data

Accuracy: Refer to the list of specifications.
(excluding quantizing error)
Resolution: 0.01mm or .0005"/0.01mm
Display: LCD
Scale type: ABSOLUTE electromagnetic induction linear encoder
Max. response speed: Unlimited
Battery: **SR44** (1 pc), **938882**,
for initial operational checks (standard accessory)
Battery life: Approx. 5,000 hours in continuous use
Dust/Water protection level: IP66 (IEC 60529)*
Standard accessory: Jaw clamps (2 pcs.), 05GZA033
*This model is not waterproof type. Please wipe away the wet after use.

Functions

Zero-setting
Data hold
Offsetting
Presetting
Data output
Low-power and low-voltage alert
Counting value composition error
Automatic power on/off, inch/mm reading
(inch/mm models)

Optional accessories

For details, refer to page A-21.
Connecting cables for **IT/DP/MUX***
05CZA624: SPC cable with data button (1m)
05CZA625: SPC cable with data button (2m)



USB Input Tool Direct

06ADV380A: SPC cable for **USB-ITN-A** (2m)
Connecting cables for **U-WAVE-T**
02AZD790A: SPC cable for U-WAVE with data button
(160mm)
02AZE140A: SPC cable for footswitch

ABSOLUTE Coolant Proof Carbon Fiber Caliper SERIES 552

- IP66 Absolute Digital Caliper (Refer to page D-8 for a description of Absolute measurement.)
- Lightweight Digimatic Calipers that employ CFRP (Carbon Fiber Reinforced Plastics) in the beam and jaws.
- Allows integration into statistical process control and measurement systems for models with measurement data output connector. Refer to page A-3.
- Zirconia ceramics are applied to the measuring surface.
- Rust-free due to the nonmagnetism and the insulation quality: most suitable for measuring magnetic parts.



552-156-10



SPECIFICATIONS

Metric		
Order No. (standard / long jaws / ceramic jaws)	Range*	Accuracy (standard / long jaws / ceramic jaws)
552-155-10	0 (20) - 450mm	±0.04mm / ±0.06mm / ±0.04mm
552-156-10	0 (20) - 600mm	

* () : Minimum dimension in inside measurement

Inch/Metric		
Order No. (standard / long jaws / ceramic jaws)	Range*	Accuracy (standard / long jaws / ceramic jaws)
552-165-10	0 (.5") - 18"	±.002" / ±.0025" / ±.002"
552-166-10	0 (.5") - 24"	

* () : Minimum dimension in inside measurement

DIMENSIONS

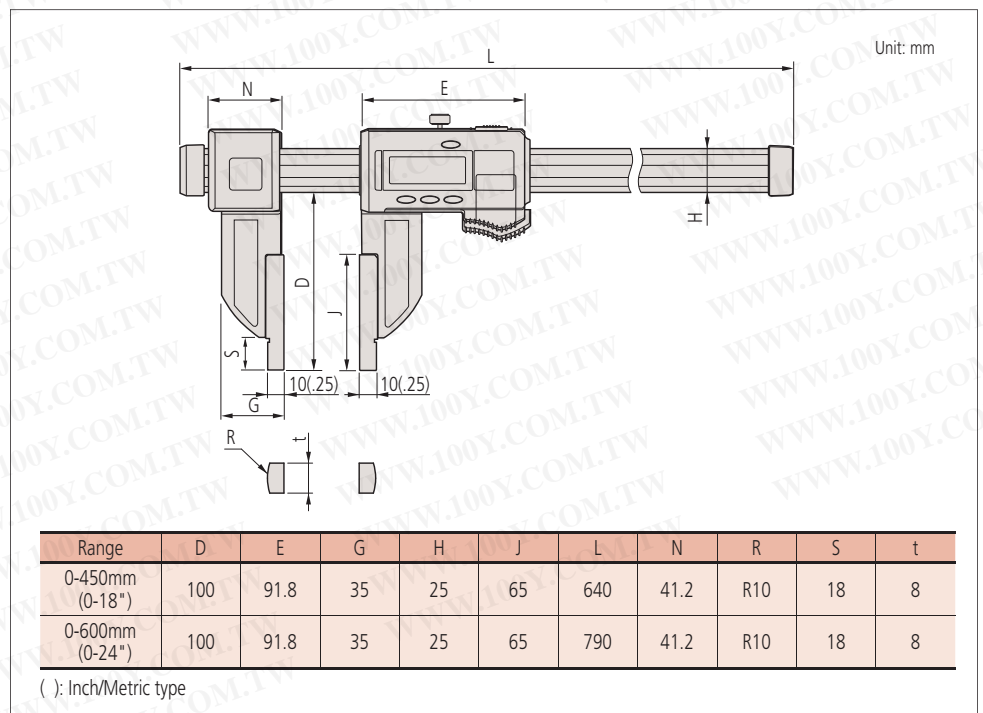

Calipers

An industry standard in measuring tools

ABSOLUTE Coolant Proof Carbon Fiber Caliper SERIES 552

- IP66 Absolute Digital Caliper (Refer to page D-8 for a description of Absolute measurement.)
- The range of applications can be expanded by using interchangeable jaws (optional).
- Allows integration into statistical process control and measurement systems for models with measurement data output connector. Refer to page A-3.
- Provided with preset function for setting a desired starting point, which allows direct readout of offset measurement.

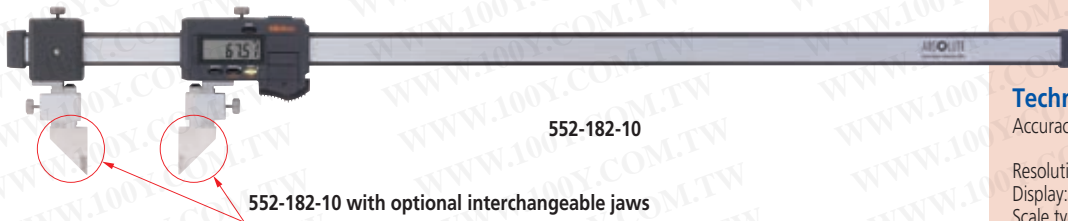

SPECIFICATIONS

Metric			Inch/Metric		
Order No.	Range	Accuracy	Order No.	Range	Accuracy
552-181-10	0 - 450mm	±0.04mm	552-191-10	0 - 18"	±.002"
552-182-10	0 - 600mm		552-192-10	0 - 24"	
552-183-10	0 - 1000mm	±0.05mm	552-193-10	0 - 40"	±.004"
552-184-10	0 - 1500mm	±0.09mm	552-194-10	0 - 60"	
552-185-10	0 - 2000mm	±0.12mm	552-195-10	0 - 80"	±.005"

ABSOLUTE™ (Refer to page IX for details.)



(Refer to page IX for details.)



(Refer to page IX for details.)

Technical Data

Accuracy: Refer to the list of specifications. (excluding quantizing error)
 Resolution: 0.01mm or .0005"/0.01mm
 Display: LCD
 Scale type: ABSOLUTE electromagnetic induction linear encoder
 Max. response speed: Unlimited
 Battery: **SR44** (1 pc), **938882**, for initial operational checks (standard accessory)
 Battery life: Approx. 5,000 hours in continuous use
 Dust/Water protection level: IP66 (IEC 60529)*
 Standard accessory: Jaw clamps (2 pcs.), 05GZA033
 * Although these models are IP66 rated, care should be taken to dry tool after use.

Functions

Zero-setting
 Data hold
 Offsetting
 Presetting
 Data output
 Low-power and low-voltage alert
 Counting value composition error
 Automatic power on/off, inch/mm reading (inch/mm models)

Standard accessories (2 pcs)

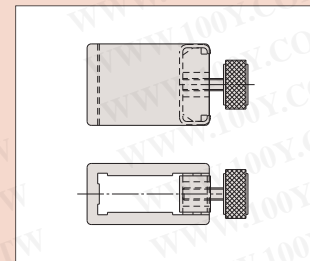

Jaw clamps: No.05GZA033

Optional accessories

For details, refer to page A-21.
 Connecting cables for **IT/DP/MUX**
05CZA624: SPC cable with data button (1m)
05CZA625: SPC cable with data button (2m)



USB Input Tool Direct

06ADV380A: SPC cable for **USB-ITN-A** (2m)
 Connecting cables for **U-WAVE-T**
02AZD790A: SPC cable for U-WAVE with data button (160mm)
02AZE140A: SPC cable for footswitch

Optional accessories

Interchangeable jaws

SPECIFICATIONS

Standard type

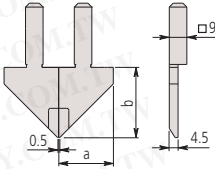

Inside point type

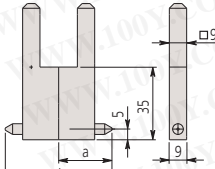

Surface Plate Type

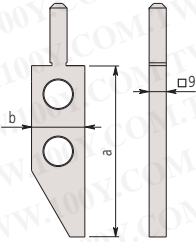

Scriber Type

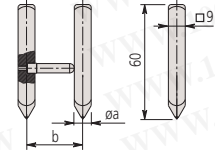

Centerline Type

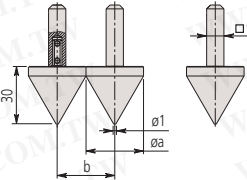

Unit: mm

Scriber for height gages

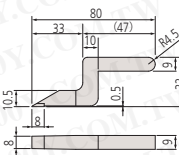

Standard Type

Order No.	Components	a	b
07CZA056	Right (07CAA044), Left (07CAA045)	28mm (1.1")	30mm (1.2")

Inside Point Type

Order No.	Components	a	b
07CZA058	07CZA041 x 2pcs.	25mm	50mm
07CZA059	07CZA048 x 2pcs.	1"	2"

Scriber Type

Order No.	Components	a	b
07CZA055	Right (07CZA042), Left (07CZA043)	8mm	30mm
07CZA061	Right (07CZA042), Left (07CZA049)	0.31"	1.2"

Surface Plate Type

Order No.	a	b
07CZA044	90mm (3.5")	28mm (1.1")

Centerline Type

Order No.	Components	a	b
07CZA057	07CZA039 x 2pcs.	30mm	30mm
07CZA060	07CZA047 x 2pcs.	1.2"	1.2"

Scriber for height gages

Order No.
07GZA000

Type	Applicable calipers	Range	Accuracy when attached to the caliper
Standard type	552-181-10 (552-191-10)	0 - 450mm (0-18")	±0.06mm (±0.025")
	552-182-10 (552-192-10)	0 - 600mm (0-24")	
	552-183-10 (552-193-10)	0 - 1000mm (0-40")	
	552-184-10 (552-194-10)	0 - 1500mm (0-60")	
552-185-10 (552-195-10)	0 - 2000mm (0-80")	±0.14mm (±0.055")	
Inside point type	552-181-10 (552-191-10)	Inside: 50 - 500mm (2-20") Outside: 0 - 450mm (0-18")	±0.09mm (±0.035")
	552-182-10 (552-192-10)	Inside: 50 - 650mm (2-26") Outside: 0 - 600mm (0-24")	
	552-183-10 (552-193-10)	Inside: 50 - 1050mm (2-42") Outside: 0 - 1000mm (0-40")	
	552-184-10 (552-194-10)	Inside: 50 - 1550mm (2-62") Outside: 0 - 1500mm (0-60")	
552-185-10 (552-195-10)	Inside: 50 - 2050mm (2-82") Outside: 0 - 2000mm (0-80")	±0.17mm (±0.070")	
Centerline type	552-181-10 (552-191-10)	30 - 480mm (1.2-19.2")	±0.08mm (±0.030")
	552-182-10 (552-192-10)	30 - 630mm (1.2-25.2")	
	552-183-10 (552-193-10)	30 - 1030mm (1.2-41.2")	
	552-184-10 (552-194-10)	30 - 1530mm (1.2-61.2")	
552-185-10 (552-195-10)	30 - 2030mm (1.2-81.2")	±0.16mm (±0.065")	
Scriber type	552-181-10 (552-191-10)	30 - 480mm (1.2-19.2")	±0.10mm (±0.040")
	552-182-10 (552-192-10)	30 - 630mm (1.2-25.2")	
	552-183-10 (552-193-10)	30 - 1030mm (1.2-41.2")	
	552-184-10 (552-194-10)	30 - 1530mm (1.2-61.2")	
552-185-10 (552-195-10)	30 - 2030mm (1.2-81.2")	±0.15mm (±0.060")	
Surface plate type + Scriber type for height gages	552-181-10 (552-191-10)	0 - 450mm (0-17.7")	±0.10mm (±0.040")
	552-182-10 (552-192-10)	0 - 600mm (0-23.7")	
	552-183-10 (552-193-10)	0 - 1000mm (0-39.4")	
	552-184-10 (552-194-10)	0 - 1500mm (0-59.4")	
552-185-10 (552-195-10)	0 - 2000mm (0-79.6")	±0.18mm (±0.070")	
Surface plate type + Inside point type	552-181-10 (552-191-10)	Inside: 25 - 475mm (1-19") Outside: 0 - 450mm (1-18")	±0.12mm (±0.050")
	552-182-10 (552-192-10)	Inside: 25 - 625mm (1-25") Outside: 0 - 600mm (1-24")	
	552-183-10 (552-193-10)	Inside: 25 - 1025mm (1-41") Outside: 0 - 1000mm (1-40")	
	552-184-10 (552-194-10)	Inside: 25 - 1525mm (1-62") Outside: 0 - 1500mm (1-60")	
552-185-10 (552-195-10)	Inside: 25 - 2025mm (1-81") Outside: 0 - 2000mm (1-80")	±0.20mm (±0.080")	
Surface plate type + Centerline type	552-181-10 (552-191-10)	15 - 465mm (0.6-18.6")	±0.11mm (±0.045")
	552-182-10 (552-192-10)	15 - 615mm (0.6-24.6")	
	552-183-10 (552-193-10)	15 - 1015mm (0.6-40.6")	
	552-184-10 (552-194-10)	15 - 1515mm (0.6-60.6")	
552-185-10 (552-195-10)	15 - 2015mm (0.6-80.6")	±0.19mm (±0.075")	

() : Inch/Metric models

Application examples

Surface plate type + Standard type

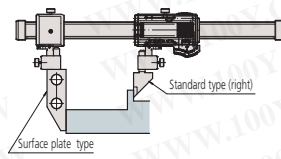

Scriber type

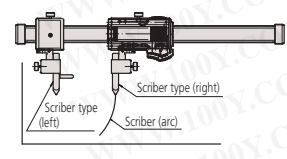

Inside point type

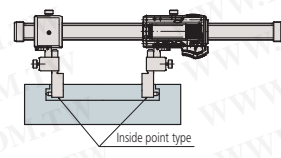

Surface plate type + Scriber for height gages

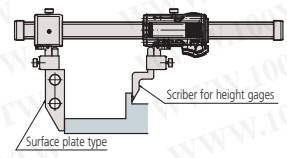

Surface plate type + Centerline type

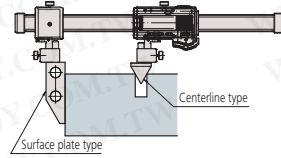

Calipers

An industry standard in measuring tools

Vernier Caliper

SERIES 160 — with Nib Style Jaws and Fine Adjustment

- Inside and outside measurements can be read directly from the upper and lower vernier scales.
- The jaws have radiused measuring faces for accurate inside diameter (ID) measurement.
- With fine adjustment (except for 160-130/131/132/133/134).



SPECIFICATIONS

Metric with inside measurement vernier scale

Order No.	Range*	Accuracy	Graduations	Remarks
160-130	0 (20) - 450mm	±0.10mm	0.05mm	without fine adjustment
160-131	0 (20) - 600mm			
160-132	0 (20) - 1000mm			
160-133	0 (20) - 1500mm			
160-134	0 (20) - 2000mm			

* (): Minimum dimension in ID measurement

Metric with inside measurement vernier scale

Order No.	Range*	Accuracy	Graduations	Remarks
160-127	0 (10) - 300mm	±0.04mm	0.02mm	—
160-128	0 (20) - 450mm	±0.05mm		
160-101	0 (20) - 600mm	±0.05mm		
160-104	0 (20) - 1000mm	±0.07mm		
160-110	0 (20) - 1500mm	±0.1mm		
160-113	0 (20) - 2000mm	±0.12mm		

* (): Minimum dimension in ID measurement

Metric/Inch with metric/inch double scale

Order No.	Range*	Accuracy	Graduations	Remarks
160-150	0 (10) - 300mm	±0.04mm	0.02mm/.001"	+10mm/.394" to reading in inside measurement
160-151	0 (20) - 450mm	±0.05mm		
160-153	0 (20) - 600mm	±0.05mm		
160-155	0 (20) - 1000mm	±0.07mm		
160-157	0 (20) - 1500mm	±0.1mm		
160-159	0 (20) - 2000mm	±0.12mm		

* (): Minimum dimension in ID measurement

Inch with inside measurement vernier scale

Order No.	Range*	Accuracy	Graduations	Remarks
160-124	0 (.3") - 12"	±.0015"	.001"	—
160-116	0 (.5") - 18"	±.002"		
160-102	0 (.5") - 24"			
160-105	0 (1") - 40"	±.003"		
160-111	0 (1") - 60"	±.004"		
160-114	0 (1") - 80"	±.005"		

* (): Minimum dimension in ID measurement

Inch/Metric with inch/metric double scale

Order No.	Range*	Accuracy	Graduations	Remarks
160-125	0 (.3") - 12"	±.0015"	.001"/0.02mm	+3"/7.62mm to reading in inside measurement
160-119	0 (.5") - 18"	±.002"		+1"/25.4mm to reading in inside measurement
160-103	0 (.5") - 24"			
160-106	0 (1") - 40"	±.003"		
160-112	0 (1") - 60"	±.004"		
160-115	0 (1") - 80"	±.005"		

* (): Minimum dimension in ID measurement

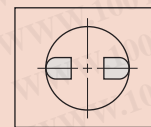
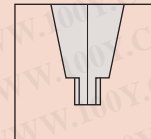

Radiused jaws for accurate ID measurement

DIMENSIONS

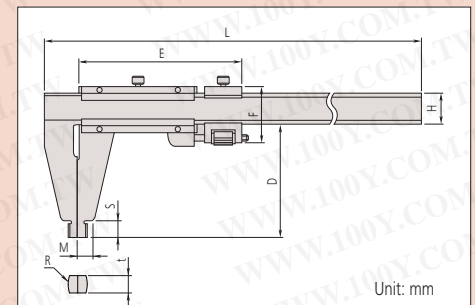

Unit: mm

Range	D	E	F	H	L	M	R	S	t
0-300mm/0-12"	75	103	38	20	445	10	R 5	12	3.8
0-450mm*	89	—	—	—	—	—	R10	18	6
0-450mm/0-18"	112	51	—	25	630	14.8	R10	18	6
0-600mm*	89	—	—	—	—	—	R10	18	6
0-600mm/0-24"	100	112	51	—	25	780	R10	18	6
0-1000mm*	140	111	—	—	—	—	R10	24	8
0-1000mm/0-40"	150	62.5	—	32	1240	17	R10	24	8
0-1500mm*	180	129	—	—	—	—	R10	30	8
0-1500mm/0-60"	170	62.5	—	32	1800	19	R10	30	8
0-2000mm*	180	129	—	—	—	—	R10	30	12
0-2000mm/0-80"	180	180	78	40	2300	23	R10	30	12

*: without fine adjustment

Long Jaw Vernier Caliper SERIES 534

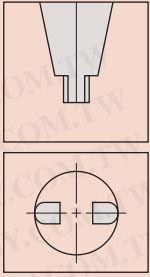

Round jaws for accurate ID measurement

- Long jaws for measuring hard-to-reach workpiece features.
- Inside and outside measurements can be read directly from the upper and lower vernier scales.



534-110

SPECIFICATIONS

Metric with inside measurement vernier scale

Order No.	Range*	Accuracy	Graduation	Remarks
534-109	0 (10) - 300mm	±0.07mm	0.05mm	without fine adjustment
534-110	0 (20) - 500mm	±0.13mm		

* (): Minimum dimension in inside measurement

Metric/Inch with metric/inch double scale

Order No.	Range*	Accuracy	Graduation	Remarks
534-101	0 (10) - 300mm	±0.07mm	0.05mm/ 1/128"	+10mm/.394" to reading in inside measurement
534-105		±0.04mm	0.02mm/.001"	
534-102	0 (20) - 500mm	±0.13mm	0.05mm/ 1/128"	+20mm/.787" to reading in inside measurement
534-106		±0.06mm	0.02mm/.001"	
534-103	0 (20) - 750mm	±0.16mm	0.05mm/ 1/128"	
534-107		±0.08mm	0.02mm/.001"	
534-104	0 (20) - 1000mm	±0.20mm	0.05mm/ 1/128"	
534-108		±0.10mm	0.02mm/.001"	

* (): Minimum dimension in inside measurement

Calipers

An industry standard in measuring tools

Long Jaw Vernier Caliper SERIES 534

- Long jaws for measuring hard-to-reach workpiece features.
- Inside and outside measurements can be read directly from the upper and lower vernier scales.

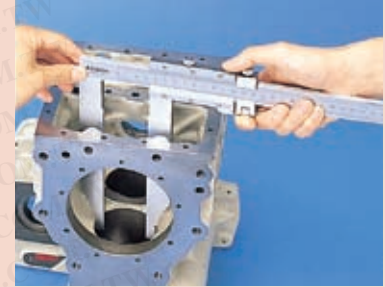

SPECIFICATIONS

Metric with inside measurement vernier scale				
Order No.	Range*	Accuracy	Graduation	Remarks
534-113	0 (10) - 300mm	±0.04mm	0.02mm	with fine adjustment
534-114	0 (20) - 500mm	±0.06mm		
534-115	0 (20) - 750mm	±0.08mm		
534-116	0 (20) - 1000mm	±0.10mm		

* (): Minimum dimension in inside measurement

Inch with inside measurement vernier scale				
Order No.	Range*	Accuracy	Graduation	Remarks
534-117	0 (.3") - 12"	±.002"	.001"	with fine adjustment
534-118	0 (.8") - 20"	±.003"		
534-119	0 (.8") - 30"	±.004"		
534-120	0 (.8") - 40"			

* (): Minimum dimension in inside measurement

DIMENSIONS

Unit: mm

Range	D	E	F	H	L	M	R	S	t
0-300mm*	90	76.5	—	20	445	7	R5	12	3.8
0-300mm/0-12"		103	38				R5		
0-500mm*	112	89	—	25	682	12	R10	18.5	6
0-500mm/0-20"		150	—				R10		
0-750mm*	150	—	—	32	995	12	R10	18.5	6
0-750mm/0-30"		62.5	—				R10		
0-1000mm*	150	—	—	32	1230	12	R10	18.5	8
0-1000mm/0-40"		62.5	—				R10		

* Without fine adjustment

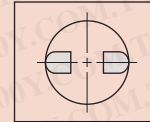
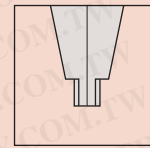

Radiused jaws for accurate ID measurement



(Refer to page IX for details.)



(Refer to page IX for details.)

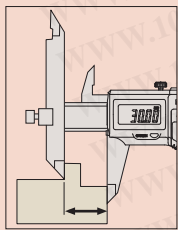
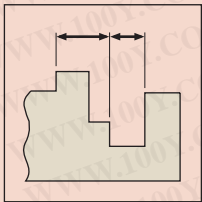

Technical Data

Accuracy: Refer to the list of specifications.
(excluding quantizing error for digital models)

Resolution*: 0.01mm or .0005"/0.01mm

Graduation**: 0.05mm

Display*: LCD

Scale type*: ABSOLUTE electromagnetic induction linear encoder

Max. response speed*: Unlimited

Battery: **SR44** (1 pc), **938882**,
for initial operational checks (standard accessory)

Battery life*: Approx. 3 years under normal use
(1 year: 300mm model)

Dust/Water protection level*: IP67 (IEC 60529)***

* Digital models ** Analog models

*** This model is not waterproof type.
Therefore, rustproofing shall be applied after use.

Optional accessories for Digital Model

For details, refer to page A-21.

959143: Data hold unit

Connecting cables for IT/DP/MUX

05CZA624: SPC cable with data button (1m)

05CZA625: SPC cable with data button (2m)

USB Input Tool Direct

06ADV380A: SPC cable for **USB-ITN-A** (2m)

Connecting cables for **U-WAVE-T**

02AZD790A: SPC cable for **U-WAVE** with data button
(160mm)

02AZE140A: SPC cable for footswitch

Offset Caliper SERIES 573, 536 — ABSOLUTE Digimatic and vernier type

- The beam-mounted jaw can be adjusted to facilitate measurement of stepped sections and hard-to-get-at workpiece features.
- Digital models are IP67 Absolute type. No need to reset the origin after switching on. (Refer to page D-8 for a description of Absolute measurement.)
- The slider operation of digital models is smooth and comfortable.
- Allows integration into statistical process control and measurement systems for models with measurement data output connector. Refer to page A-3.



SPECIFICATIONS

Metric	Digital model	
Order No.	Range	Accuracy
573-601	0 - 150mm	±0.02mm
573-611*	0 - 150mm	±0.02mm
573-602	0 - 200mm	±0.02mm
573-612*	0 - 200mm	±0.02mm
573-604	0 - 300mm	±0.03mm
573-614*	0 - 300mm	±0.03mm

* Without thumb roller

Metric	Analog model	
Order No.	Range	Accuracy
536-101	0 - 150mm	±0.05mm
536-102	0 - 200mm	±0.05mm
536-103	0 - 300mm	±0.08mm

Inch/Metric	Digital model	
Order No.	Range	Accuracy
573-701	0 - 6"	±.001"
573-702	0 - 8"	±.001"
573-704	0 - 12"	±.0015"

DIMENSIONS

Unit: mm

Model	D	G	J	N	W
Digital model	40	10	30	10	95
	50	10	38.5	10	95
	64	15	51	15	135
Analog model	40	10	30	10	95
	50	10	38.5	10	95
	64	15	51	15	135

Calipers

An industry standard in measuring tools

Offset Centerline Caliper SERIES 573, 536 — ABSOLUTE Digimatic and vernier type

- Specially designed for hole Center-to-Center measurements on the same, or offset, planes.
- Digital models are IP67 Absolute type. No need to reset the origin after switching on. (Refer to page D-8 for a description of Absolute measurement.)
- The slider operation of digital models is smooth and comfortable.
- Direct reading of pitch measurements is available due to the offset-value setting function.
- Allows integration into statistical process control and measurement systems for models with measurement data output connector. Refer to page A-3.



SPECIFICATIONS

Metric	Digital model	
Order No.	Range	Accuracy
573-605	10 - 160mm	±0.03mm
573-615*	10 - 160mm	±0.03mm
573-606	10 - 210mm	±0.03mm
573-616*	10 - 210mm	±0.03mm
573-608	10 - 310mm	±0.04mm
573-618*	10 - 310mm	±0.04mm

* Without thumb roller

Metric	Analog model	
Order No.	Range	Accuracy
536-105	10 - 150mm	±0.05mm
536-106	10 - 200mm	±0.05mm
536-107	10 - 300mm	±0.08mm

Inch/Metric	Digital model	
Order No.	Range	Accuracy
573-705	.4 - 6.4"	±.0015"
573-706	.4 - 8.4"	±.0015"
573-708	.4 - 12.4"	±.0015"

DIMENSIONS

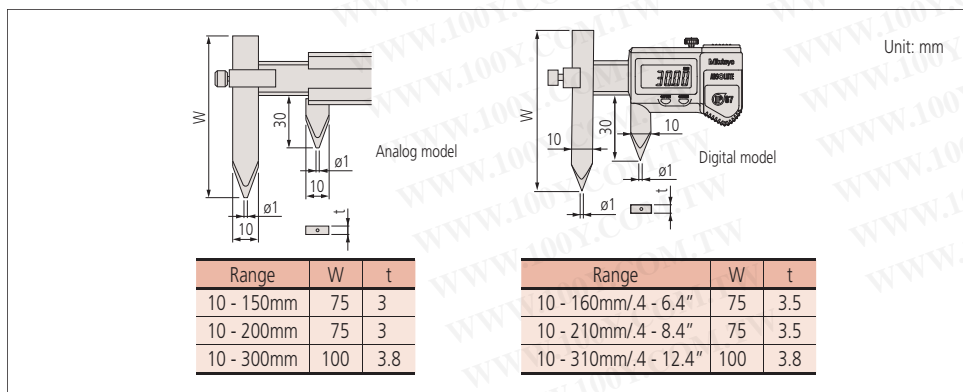

(Refer to page IX for details.)



(Refer to page IX for details.)

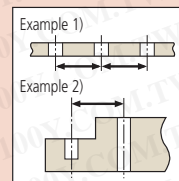
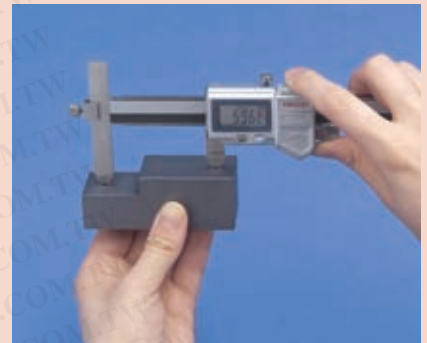

Technical Data

Accuracy: Refer to the list of specifications. (excluding quantizing error for digital models)
 Resolution*: 0.01mm or .0005"/0.01mm
 Graduation**: 0.05mm
 Display*: LCD
 Scale type*: ABSOLUTE electromagnetic induction linear encoder
 Max. response speed*: Unlimited
 Battery: **SR44** (1 pc), **938882**, for initial operational checks (standard accessory)
 Battery life*: Approx. 3 years under normal use (1 year: 310mm model)
 Dust/Water protection level*: IP67 (IEC 60529)**
 * Digital models ** Analog models
 *** This model is not waterproof type. Therefore, rustproofing shall be applied after use.

Optional accessories for Digital Models

For details, refer to page A-21.
959143: Data hold unit
 Connecting cables for IT/DP/MUX
05CZA624: SPC cable with data button (1m)
05CZA625: SPC cable with data button (2m)
USB Input Tool Direct
06ADV380A: SPC cable for **USB-ITN-A** (2m)
 Connecting cables for **U-WAVE-T**
02AZD790A: SPC cable for **U-WAVE** with data button (160mm)
02AZE140A: SPC cable for footswitch



Technical Data

Accuracy: Refer to the list of specifications.
(excluding quantizing error)
Resolution: 0.01mm or .0005"/0.01mm
Display: LCD
Scale type: ABSOLUTE electrostatic capacity linear encoder
Max. response speed: Unlimited
Battery: **SR44** (1 pc, **938882**,
for initial operational checks (standard accessory)
Battery life: Approx. 3.5 years under normal use

Optional accessories

For details, refer to page A-21.
959143: Data hold unit
Connecting cables for IT/DP/MUX
959149: SPC cable with data button (1m)
959150: SPC cable with data button (2m)
USB Input Tool Direct
06ADV380C: SPC cable for **USB-ITN-C** (2m)
Connecting cables for **U-WAVE-T**
02AZD790C: SPC cable for **U-WAVE** with data button
(160mm)
02AZE140C: SPC cable for footswitch
05FAJ735: Centerline caliper inspection gage

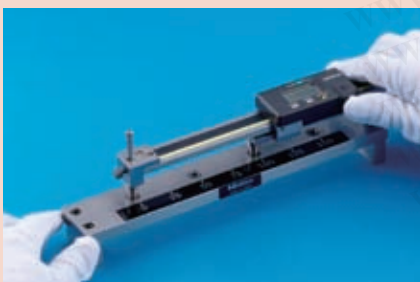
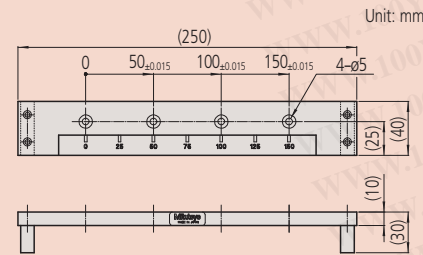

**ABSOLUTE Back-Jaw Centerline Caliper
SERIES 573 - Center-to-Center & Edge-to-Center Types**

- Specially designed to measure hole Center-to-Center and Edge-to-Center distances.
- Provided with jaws on the back of the slider, measurements can be read easily from above.
- Allows integration into statistical process control and measurement systems for models with measurement data output connector. Refer to page A-3.
- Dedicated calibration inspection tools are available.

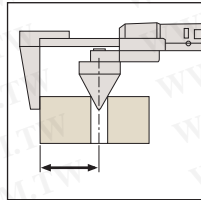

- A digital model is IP67 Absolute type. (Refer to page D-8 for Absolute function.)
- Direct reading of pitch measurements is available due to the offset value setting function.



SPECIFICATIONS

Metric	Edge-to-center distance type	
Order No.	Range	Accuracy
573-118-10	10 - 200mm	±0.10mm
573-119-10	10 - 300mm	±0.15mm

Metric	Center-to-center distance type	
Order No.	Range	Accuracy
573-116-10	10 - 200mm	±0.10mm
573-117-10	10 - 300mm	±0.15mm

DIMENSIONS

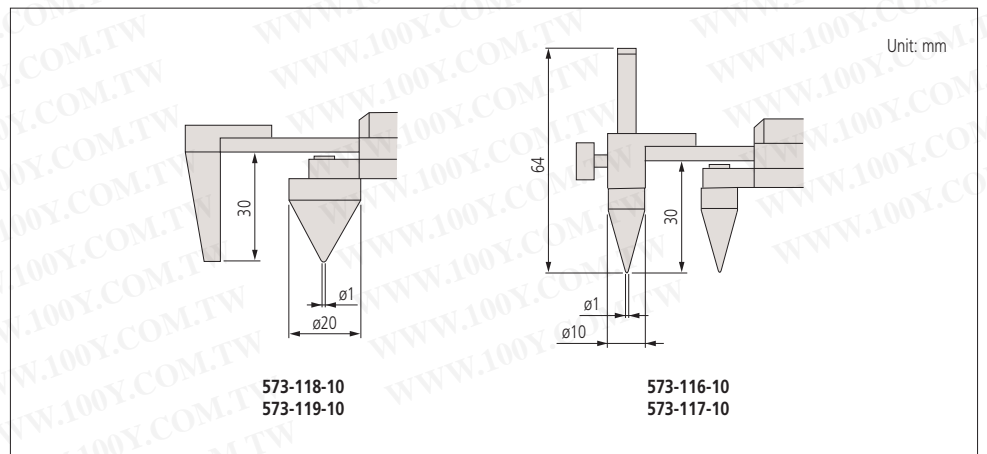

Calipers

An industry standard in measuring tools

Point Caliper

SERIES 573, 536 — ABSOLUTE Digimatic and vernier type

- Narrow-tip jaws fit into very small grooves and tracks, making many previously difficult outside measurements far easier to obtain.
- Allows step measurement.
- Digital models are IP67 Absolute type. No need to reset the origin after switching on. (Refer to page D-8 for a description of Absolute measurement.)
- Smooth slider operation with the digital models.
- SPC output models allow integration into statistical process control and measurement systems. Refer to page A-3.



573-621
ABSOLUTE™

536-121

SPECIFICATIONS

Metric	Digital model	
Order No.	Range	Accuracy
573-621	0 - 150mm	±0.02mm
573-625	0 - 150mm	±0.02mm
573-622*	0 - 150mm	±0.02mm
573-626*	0 - 150mm	±0.02mm

* without thumb roller

Metric	Digital model	
Order No.	Range	Accuracy
536-121	0 - 150mm	±0.05mm

Inch/Metric	Digital model	
Order No.	Range	Accuracy
573-721	0 - 6"	±.001"
573-725	0 - 6"	±.001"

DIMENSIONS

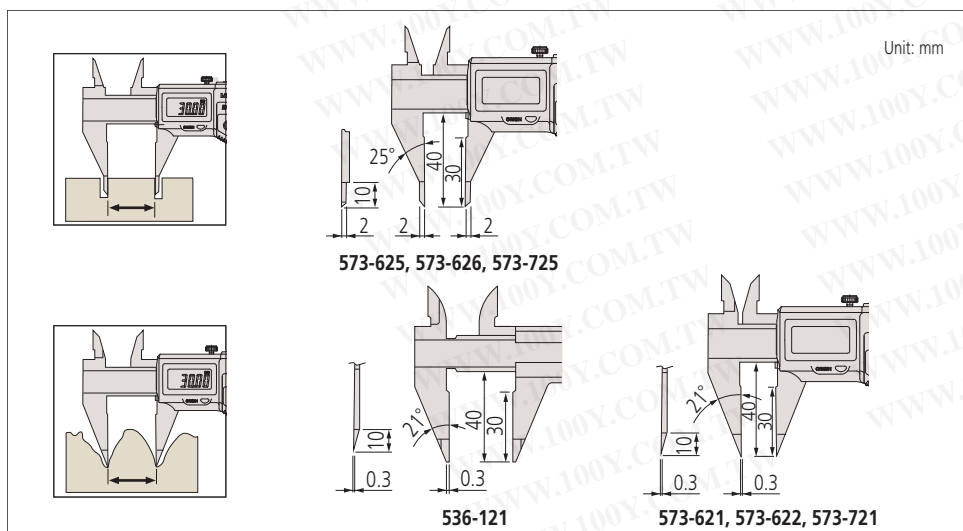

(Refer to page IX for details.)



(Refer to page IX for details.)



Technical Data

Accuracy: Refer to the list of specifications.
(excluding quantizing error for digital models)
Resolution*: 0.01mm or .0005"/0.01mm
Graduation**: 0.05mm
Display*: LCD
Scale type*: ABSOLUTE electromagnetic induction linear encoder
Max. response speed*: Unlimited
Battery: **SR44** (1 pc), **938882**,
for initial operational checks (standard accessory)
Battery life*: Approx. 3 years under normal use
Dust/Water protection level*: IP67 (IEC 60529)***
* Digital models ** Analog models
*** This model is not waterproof type.
Therefore, rustproofing shall be applied after use.

Optional accessories for Digital Models

For details, refer to page A-21.
Connecting cables for IT/DP/MUX
05CZA624: SPC cable with data button (1m)
05CZA625: SPC cable with data button (2m)
USB Input Tool Direct
06ADV380A: SPC cable for **USB-ITN-A** (2m)
Connecting cables for **U-WAVE-T**
02AZD790A: SPC cable for **U-WAVE** with data button
(160mm)
02AZE140A: SPC cable for footswitch



(Refer to page IX for details.)



(Refer to page IX for details.)

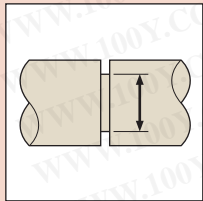

Technical Data

Accuracy: Refer to the list of specifications.
(excluding quantizing error for digital models)

Resolution*: 0.01mm or .0005"/0.01mm

Graduation**: 0.05mm

Display*: LCD

Scale type*: ABSOLUTE electromagnetic induction linear encoder

Max. response speed*: Unlimited

Battery: **SR44** (1 pc), **938882**,
for initial operational checks (standard accessory)

Battery life*: Approx. 3 years under normal use

Dust/Water protection level*: IP67 (IEC 60529)***

* Digital models ** Analog models

*** This model is not waterproof type.
Therefore, rustproofing shall be applied after use.

Optional accessories for Digital Models

For details, refer to page A-21.

Connecting cables for IT/DP/MUX

05CZA624: SPC cable with data button (1m)

05CZA625: SPC cable with data button (2m)

USB Input Tool Direct

06ADV380A: SPC cable for **USB-ITN-A** (2m)

Connecting cables for **U-WAVE-T**

02AZD790A: SPC cable for **U-WAVE** with data button (160mm)

02AZE140A: SPC cable for footswitch

Blade Type Caliper SERIES 573, 536 — ABSOLUTE Digimatic and vernier type

- The thin blade-type jaws fit into very small grooves and make previously difficult outside measurements far easier to obtain.
- The outside measuring faces are carbide tipped.
- Allows step measurement.
- Digital models are IP67 Absolute type. No need to reset the origin after switching on. (Refer to page D-8 for a description of Absolute measurement.)
- The slider operation of digital models is smooth and comfortable.
- Allows integration into statistical process control and measurement systems for models with measurement data output connector. Refer to page A-3.



SPECIFICATIONS

Metric	Digital model	
Order No.	Range	Accuracy
573-634	0 - 150mm	±0.02mm
573-635*	0 - 150mm	±0.02mm

* without thumb roller

Metric		
Order No.	Range	Accuracy
536-134	0 - 150mm	±0.05mm
536-135	0 - 200mm	±0.05mm
536-136	0 - 300mm	±0.08mm

Inch/Metric	Digital model	
Order No.	Range	Accuracy
573-734	0 - 6"	±.001"

DIMENSIONS

Range	D	d	e	t
0 - 150mm	40	20	0.75	3
0 - 200mm	50	25	0.75	3
0 - 300mm	64	30	1	3.8

Unit: mm

Calipers

An industry standard in measuring tools

ABSOLUTE Inside Caliper SERIES 573, 536 — Knife-edge/Inside Groove/Point Jaw Type

- Specially designed for inside measurements in hard-to-reach places.
- Digital models are IP67 Absolute type. No need to reset the origin after switching on. (Refer to page D-8 for a description of Absolute measurement.)
- The slider operation of digital model is smooth and comfortable.
- Allows integration into statistical process control and measurement systems for models with measurement data output connector. Refer to page A-3.

Knife-edge type



Inside groove type

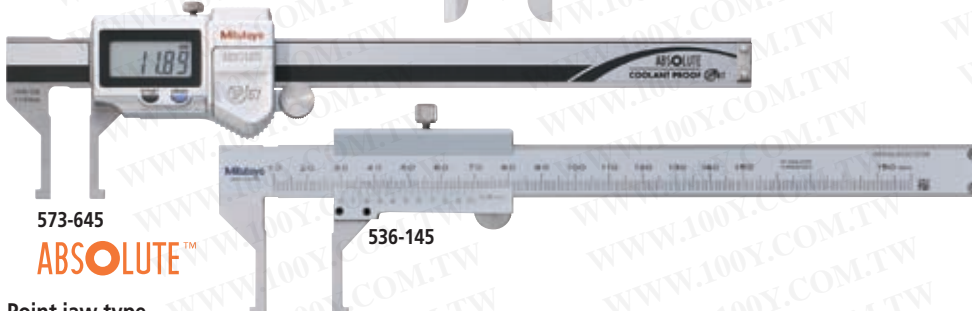

Point jaw type



SPECIFICATIONS

Metric		Digital model	
Order No.	Range	Accuracy	Remarks
573-642	10 - 200mm	±0.05mm	Knife-edge type, Measurable min. hole diameter: ø10mm
573-643*	10 - 200mm	±0.05mm	Knife-edge type, Measurable min. hole diameter: ø10mm
573-645**	10 - 160mm	±0.05mm	Inside groove type, Measurable min. hole diameter: ø10mm
573-647*	10 - 160mm	±0.05mm	Inside groove type, Measurable min. hole diameter: ø10mm
573-646**	20 - 170mm	±0.03mm	Point jaw type, Measurable min. hole diameter: ø20mm
573-648*	20 - 170mm	±0.03mm	Point jaw type, Measurable min. hole diameter: ø20mm

* without thumb roller

** Incorporated with the offsetting function, which indicates the actual measurement value.

Metric			
Order No.	Range	Accuracy	Remarks
536-142	10 - 200mm	±0.12mm	Knife-edge type, Measurable min. hole diameter: ø10mm
536-145	10 - 150mm	±0.05mm	Inside groove type, Measurable min. hole diameter: ø10mm
536-146	20 - 150mm	±0.05mm	Point jaw type, Measurable min. hole diameter: ø20mm
536-147	30 - 300mm	±0.08mm	Point jaw type, Measurable min. hole diameter: ø30mm
536-148	70 - 450mm	±0.10mm	Point jaw type, Measurable min. hole diameter: ø70mm
536-149	70 - 600mm	±0.12mm	Point jaw type, Measurable min. hole diameter: ø70mm

Inch/Metric		Digital model	
Order No.	Range	Accuracy	Remarks
573-742	.4" - 8"	±.002"	Knife-edge type, Measurable min. hole diameter: ø.4"
573-745**	.4" - 6"	±.002"	Inside groove type, Measurable min. hole diameter: ø.4"
573-746**	.8" - 6"	±.0015"	Point jaw type, Measurable min. hole diameter: ø.8"

** Incorporated with the offsetting function, which indicates the actual measurement value.



(Refer to page IX for details.)



(Refer to page IX for details.)



Technical Data

Accuracy: Refer to the list of specifications.
(excluding quantizing error for digital models)
Resolution*: 0.01mm or .0005"/0.01mm
Graduation**: 0.05mm
Display*: LCD
Scale type*: ABSOLUTE electromagnetic induction linear encoder
Max. response speed*: Unlimited
Battery: **SR44** (1 pc), **938882**,
for initial operational checks (standard accessory)
Battery life*: Approx. 3 years under normal use
Dust/Water protection level*: IP67 (IEC 60529)**
* Digital models ** Analog models
*** This model is not waterproof type.
Therefore, rustproofing shall be applied after use.

Optional accessories

For details, refer to page A-21.
Connecting cables for IT/DP/MUX
05CZA624: SPC cable with data button (1m)
05CZA625: SPC cable with data button (2m)
USB Input Tool Direct
06ADV380A: SPC cable for **USB-ITN-A** (2m)
Connecting cables for **U-WAVE-T**
02AZD790A: SPC cable for **U-WAVE** with data button (160mm)
02AZE140A: SPC cable for footswitch

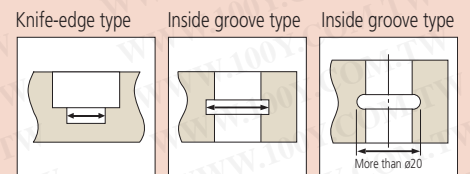

DIMENSIONS

Unit: mm

Knife-edge type: 536-142

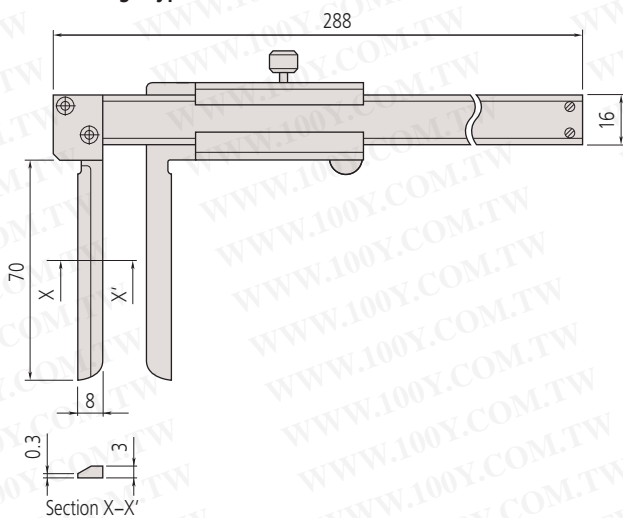

Knife-edge type: 573-642, 643, 742

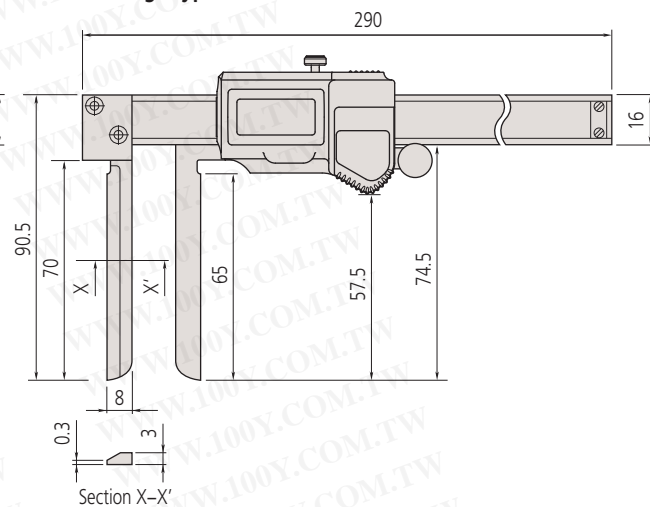

Inside groove type: 536-145

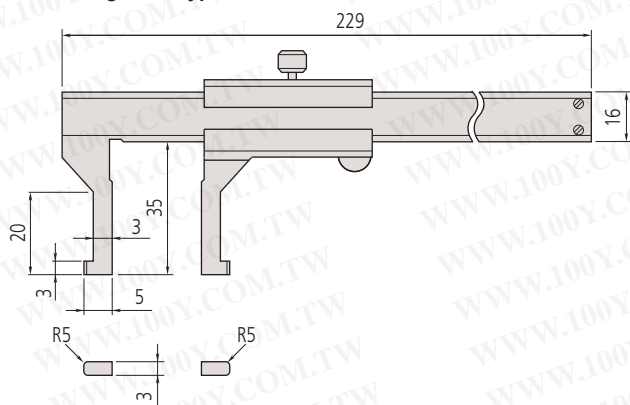

Inside groove type: 573-645, 647, 745

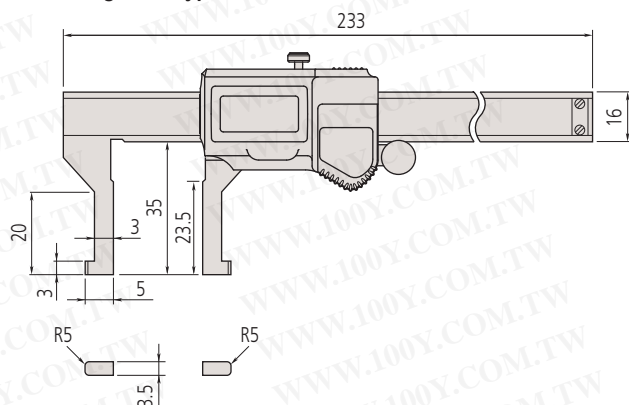

Point jaw type: 536-146, 147, 148, 149

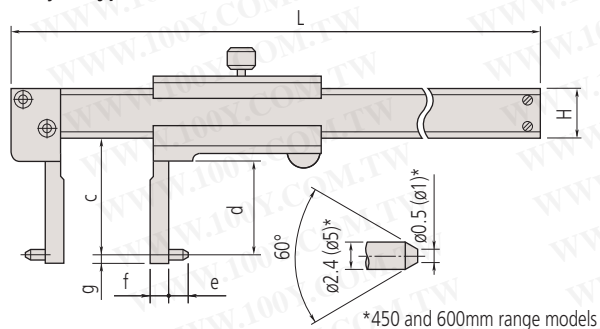

Point jaw type: 573-646, 648, 746

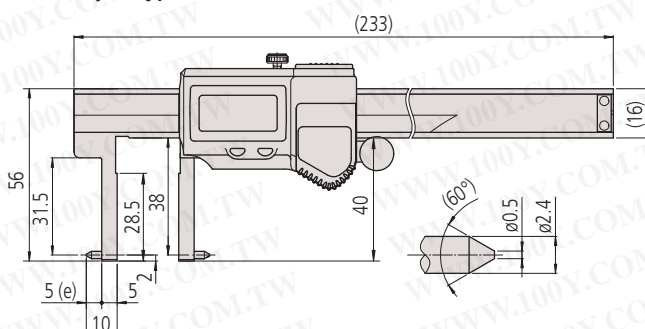

*450 and 600mm range models

Range	c	d	e	f	g	H	L
150mm	38	31	5	5	2	16	229
300mm	98	89	5	10	2	20	403
450mm	145	136	10	25	5	25	610
600mm	145	136	10	25	5	25	750

Calipers

An industry standard in measuring tools

Neck Caliper SERIES 573, 536 — ABSOLUTE Digimatic and vernier type

- Can measure wall thickness inside bores and recesses.
- Digital models are an IP67 Absolute type.
- The slider operation of digital models is smooth and comfortable.
- Allows integration into statistical process control and measurement systems for models with measurement data output connector. Refer to page A-3.



573-651

ABSOLUTE™

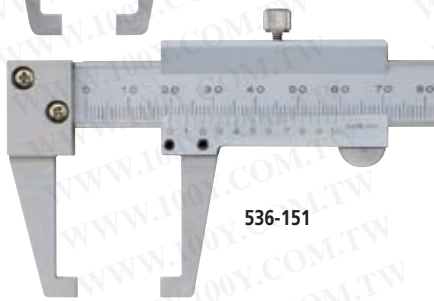

536-151

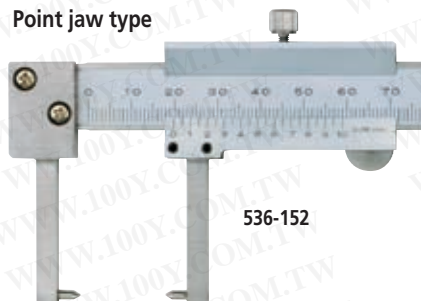

536-152

Point jaw type

SPECIFICATIONS

Metric	Digital model	
Order No.	Range	Accuracy
573-651	0 - 150mm	±0.03mm
573-652*	0 - 150mm	±0.03mm
573-653**	0 - 150mm	±0.03mm
573-654***	0 - 150mm	±0.03mm

* Point type

** Without thumb roller

Metric	Digital model	
Order No.	Range	Accuracy
536-151	0 - 150mm	±0.05mm
536-152*	0 - 150mm	±0.05mm

* Point type

DIMENSIONS

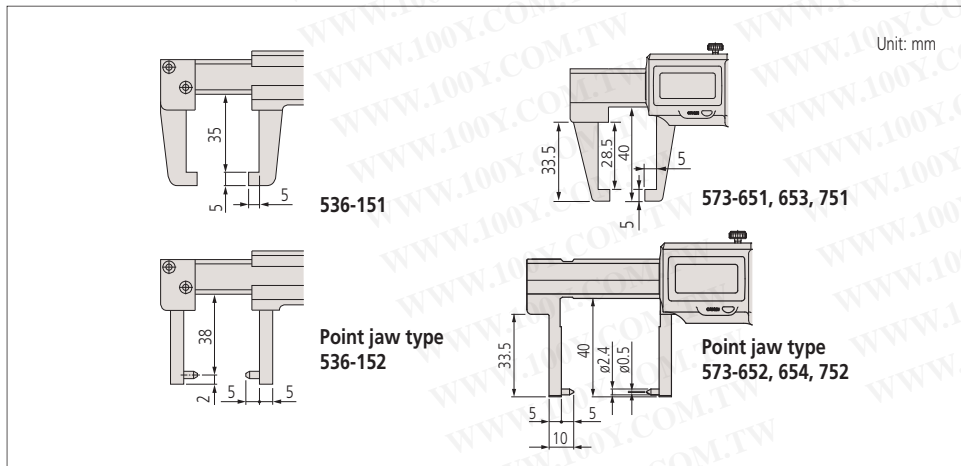

Unit: mm



(Refer to page IX for details.)



(Refer to page IX for details.)

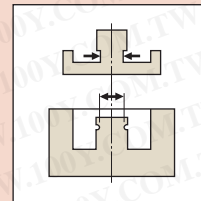
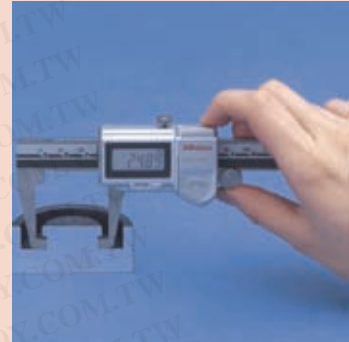

Technical Data

Accuracy: Refer to the list of specifications.

(excluding quantizing error for digital models)

Resolution*: 0.01mm or .0005"/0.01mm

Graduation*: 0.05mm

Display*: LCD

Scale type*: ABSOLUTE electromagnetic induction linear encoder

Max. response speed*: Unlimited

Battery: **SR44** (1 pc), **938882**,

for initial operational checks (standard accessory)

Battery life*: Approx. 3 years under normal use

Dust/Water protection level*: IP67 (IEC 60529)***

* Digital models ** Analog models

*** This model is not waterproof type.

Therefore, rustproofing shall be applied after use.

Optional accessories

For details, refer to page A-21.

Connecting cables for IT/DP/MUX

05CZA624: SPC cable with data button (1m)

05CZA625: SPC cable with data button (2m)

USB Input Tool Direct

06ADV380A: SPC cable for **USB-ITN-A** (2m)

Connecting cables for **U-WAVE-T**

02AZD790A: SPC cable for **U-WAVE** with data button (160mm)

02AZE140A: SPC cable for footswitch



(Refer to page IX for details.)



(Refer to page IX for details.)

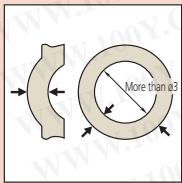
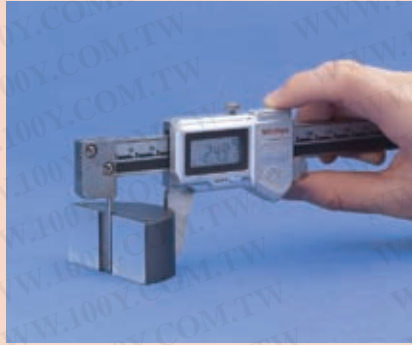

Technical Data

Accuracy: Refer to the list of specifications.
(excluding quantizing error for digital models)
Resolution*: 0.01mm or .0005"/0.01mm
Graduation**: 0.05mm
Display*: LCD
Scale type*: ABSOLUTE electromagnetic induction linear encoder
Max. response speed*: Unlimited
Battery: **SR44** (1 pc), **938882**,
for initial operational checks (standard accessory)
Battery life*: Approx. 3 years under normal use
Dust/Water protection level*: IP67 (IEC 60529)***
* Digital models ** Analog models
*** This model is not waterproof type.
Therefore, rustproofing shall be applied after use.

Optional accessories

For details, refer to page A-21.
Connecting cables for IT/DP/MUX
05CZA624: SPC cable with data button (1m)
05CZA625: SPC cable with data button (2m)
USB Input Tool Direct
06ADV380A: SPC cable for **USB-ITN-A** (2m)
Connecting cables for **U-WAVE-T**
02AZD790A: SPC cable for **U-WAVE** with data button
(160mm)
02AZE140A: SPC cable for footswitch

Tube Thickness Caliper SERIES 573, 536 — ABSOLUTE Digimatic and vernier type

- The beam-mounted jaw is a round bar that facilitates measurements of tube wall thickness.
- Digital models are IP67 Absolute type. No need to reset the origin after switching on. (Refer to page D-8 for a description of Absolute measurement.)
- The slider operation of digital models is smooth and comfortable.
- Allows integration into statistical process control and measurement systems for models with measurement data output connector. Refer to page A-3.

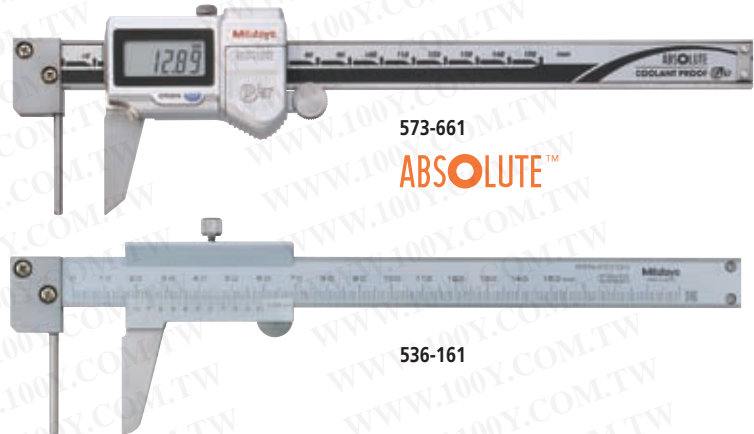

SPECIFICATIONS

Metric	Digital model	
Order No.	Range	Accuracy
573-661	0 - 150mm	±0.05mm
573-662*	0 - 150mm	±0.05mm

* without thumb roller

Metric	Analog model	
Order No.	Range	Accuracy
536-161	0 - 150mm	±0.05mm

Inch/Metric	Digital model	
Order No.	Range	Accuracy
573-761	0 - 6"	±.002"

DIMENSIONS

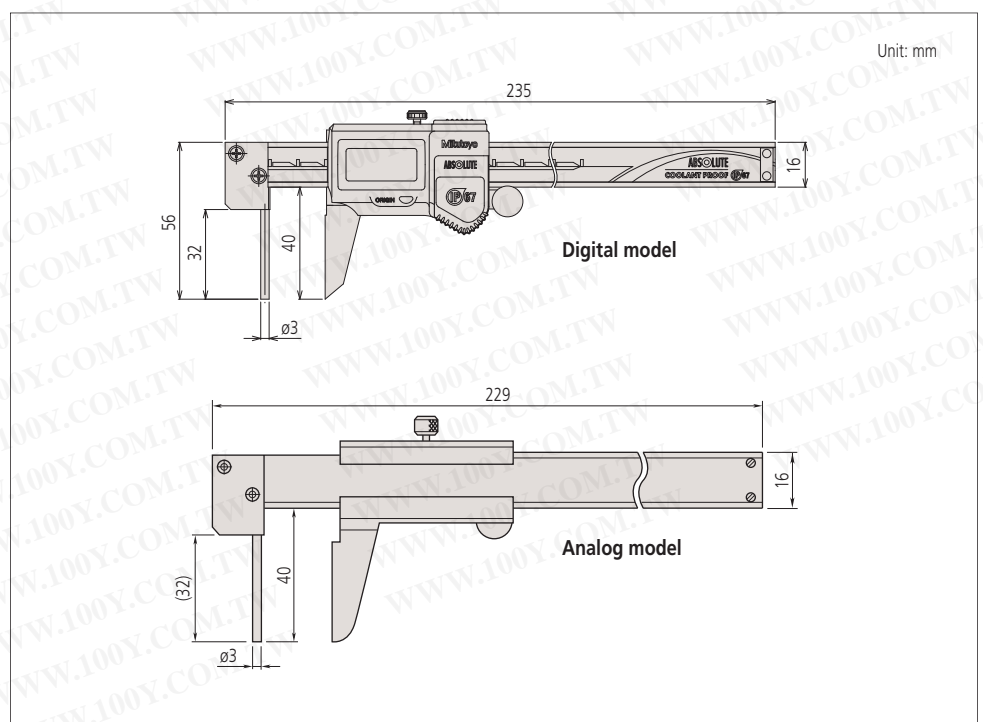

Calipers

An industry standard in measuring tools

Hook Type Vernier Caliper SERIES 536

- Can measure width of grooves and lands inside bores and recesses.



536-171

Inside-groove type



536-172

SPECIFICATIONS

Metric			
Order No.	Range*	Accuracy	Remarks
536-171	0 (10) - 200mm	±0.03mm	—
536-172	0 (2) - 200mm	±0.03mm	with fine adjustment

*() : Minimum dimension in inside measurement

DIMENSIONS

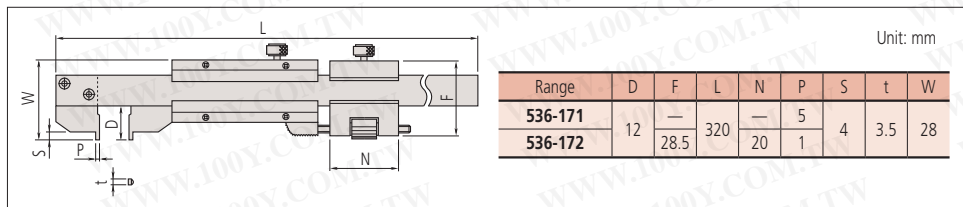

Technical Data

Accuracy: ±0.03mm
Graduation: 0.02mm

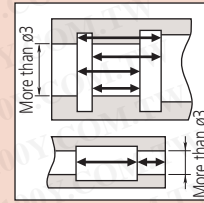
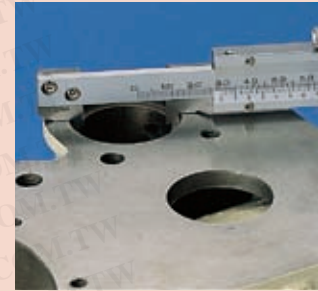

Swivel Vernier Caliper SERIES 536 — Moving Jaw type

- The moving jaw can be rotated to measure sectioned shafts.
- Allows step measurement.

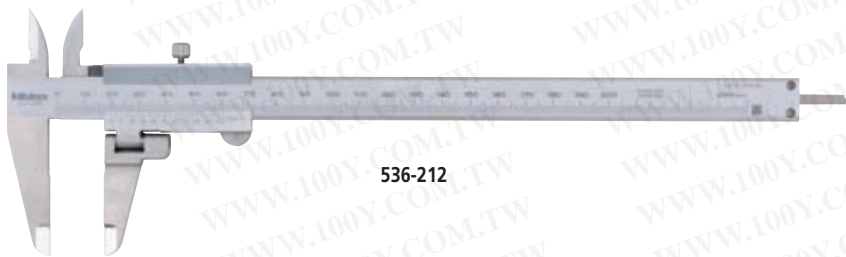

536-212

SPECIFICATIONS

Metric		
Order No.	Range	Accuracy
536-212	0 - 200mm	±0.05mm

DIMENSIONS

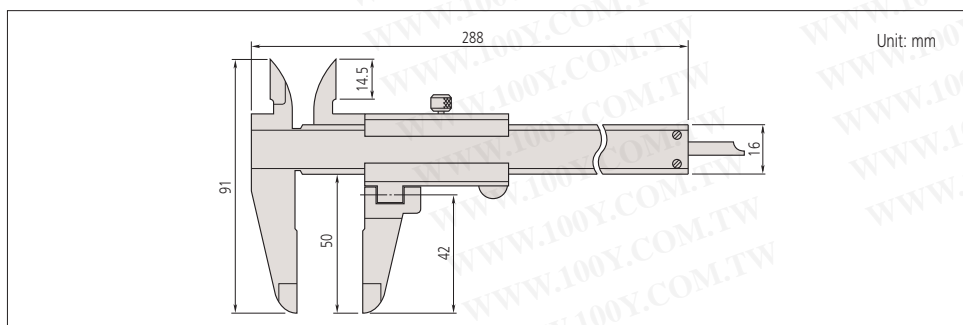

Technical Data

Accuracy: ±0.05mm
Graduation: 0.05mm



Absolute Low Force Caliper SERIES 573



Technical Explanation

Measurement procedure



A consistently low measuring force can be guaranteed by only taking measurements when the pointer is between the two fiducial lines.

- Due to the low measuring force, these calipers are ideal for measuring elastic workpieces such as plastic parts and rubber parts that standard calipers cannot measure accurately.
- Allows fine feeding easily by using thumb roller.
- Displacement of main scale jaw is 0.3mm.
- Measuring force: 0.49N to 0.98N (50gf to 100gf)
- Absolute type. (Refer to page D-8 for a description of Absolute measurement.)
- Slider operation is smooth and comfortable.
- Allows integration into statistical process control and measurement systems for models with measurement data output connector. Refer to page A-3.



573-191-20

Technical Data

- Accuracy: Refer to the list of specifications. (excluding quantizing error)
- Resolution: 0.01mm or .0005"/0.01mm
- Display: LCD
- Scale type*: ABSOLUTE electrostatic capacity linear encoder
- Jaw retraction: 0.3mm
- Max. response speed: Unlimited
- Battery: **SR44** (1 pc), **938882**, for initial operational checks (standard accessory)
- Battery life: Approx. 3.5 years under normal use

Optional accessories

- For details, refer to page A-21.
- 959143**: Data hold unit
- Connecting cables for IT/DP/MUX
- 959149**: SPC cable with data button (1m)
- 959150**: SPC cable with data button (2m)
- USB Input Tool Direct**
- 06ADV380C**: SPC cable for **USB-ITN-C** (2m)
- Connecting cables for **U-WAVE-T**
- 02AZD790C**: SPC cable for **U-WAVE** with data button (160mm)
- 02AZE140C**: SPC cable for footswitch

SPECIFICATIONS

Metric			Inch/Metric		
Order No.	Range	Accuracy	Order No.	Range	Accuracy
573-191-20	0 - 180mm	±0.05mm	573-291-20	0 - 7"	±.002"

DIMENSIONS

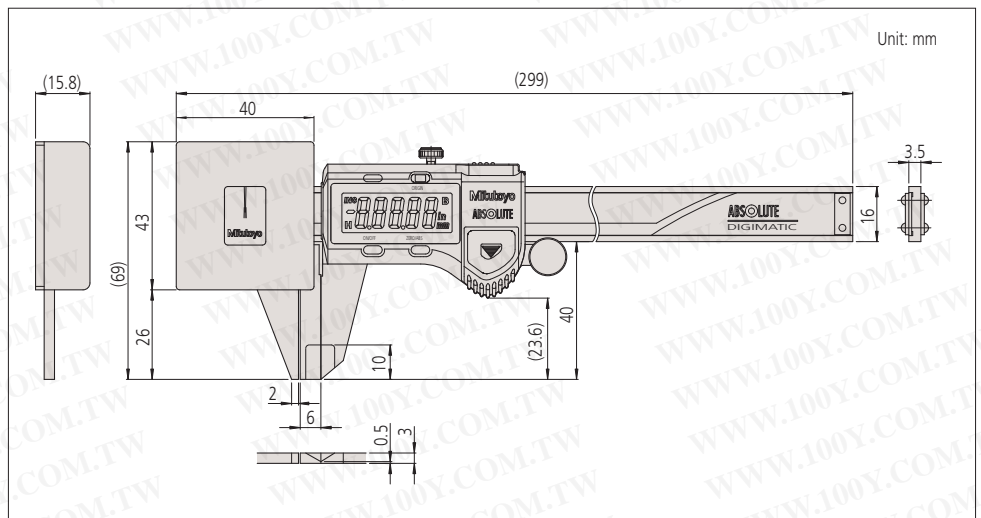

Calipers

An industry standard in measuring tools

Absolute Snap Caliper SERIES 573

- Snap mechanism allows continuous and easy measurement without moving the slider by using the lever.
- The ABSOLUTE Digimatic snap caliper features a spring-loaded mechanism to allow quick and efficient GO/NO-GO inspection for mass production parts.
- Allows step measurement
- Displacement of snap part is 2 mm.
- Measuring force: 7N to 14N (700gf to 1400gf)
- Absolute type. (Refer to page D-8 for a description of Absolute measurement.)
- Slider operation is smooth and comfortable.
- Allows integration into statistical process control and measurement systems for models with measurement data output connector. Refer to page A-3.

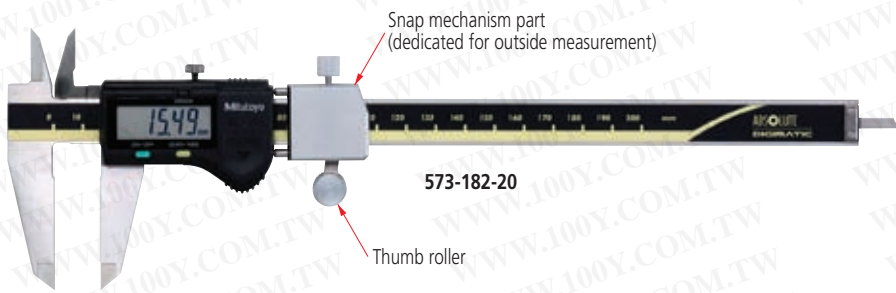

SPECIFICATIONS

Metric		
Order No.	Range	Accuracy
573-181-20	0 - 100mm	±0.02mm
573-182-20	0 - 150mm	±0.02mm

Inch/Metric		
Order No.	Range	Accuracy
573-281-20	0 - 4"	±.001"
573-282-20	0 - 6"	±.001"

DIMENSIONS

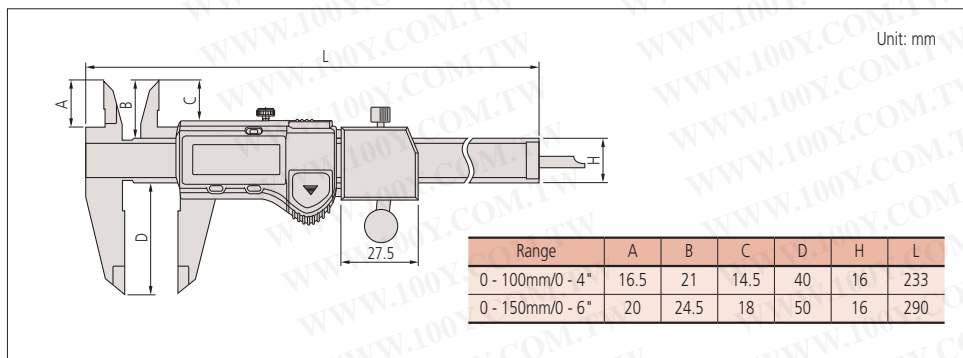

ABSOLUTE™ (Refer to page IX for details.)



Technical Data

Accuracy: Refer to the list of specifications. (excluding quantizing error)
 Resolution: 0.01mm or .0005"/0.01mm
 Repeatability: 0.01mm
 Display: LCD
 Scale type: ABSOLUTE electrostatic capacity linear encoder
 Jaw retraction: 2mm
 Max. response speed: Unlimited
 Battery: **SR44** (1 pc), **938882**, for initial operational checks (standard accessory)
 Battery life: Approx. 3.5 years under normal use

Optional accessories

For details, refer to page A-21.
959143: Data hold unit
 Connecting cables for IT/DP/MUX
959149: SPC cable with data button (1m)
959150: SPC cable with data button (2m)
USB Input Tool Direct
06ADV380C: SPC cable for **USB-ITN-C** (2m)
 Connecting cables for **U-WAVE-T**
02AZD790C: SPC cable for **U-WAVE** with data button (160mm)
02AZE140C: SPC cable for footswitch

Quick Guide to Precision Measuring Instruments



Calipers

Nomenclature

Vernier Caliper

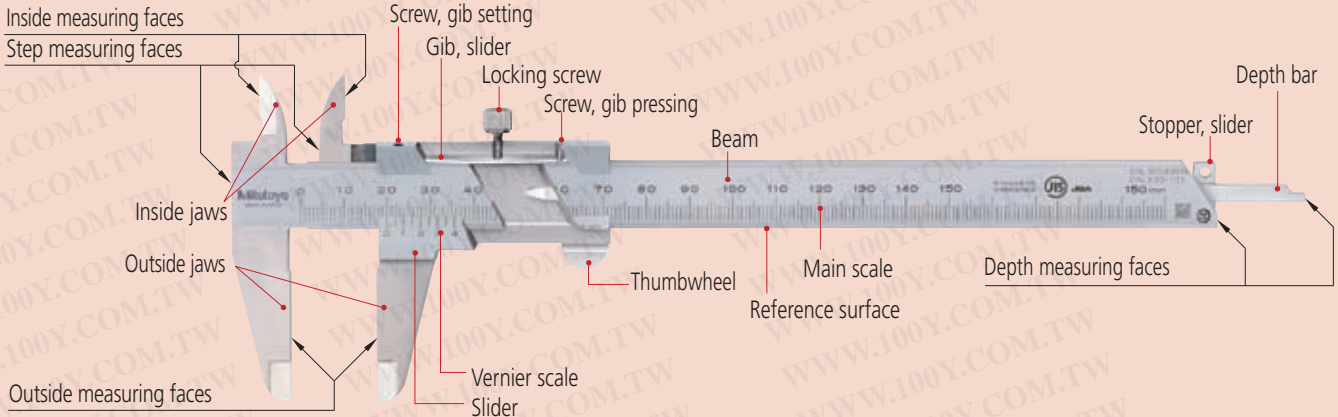

Absolute Digimatic Caliper

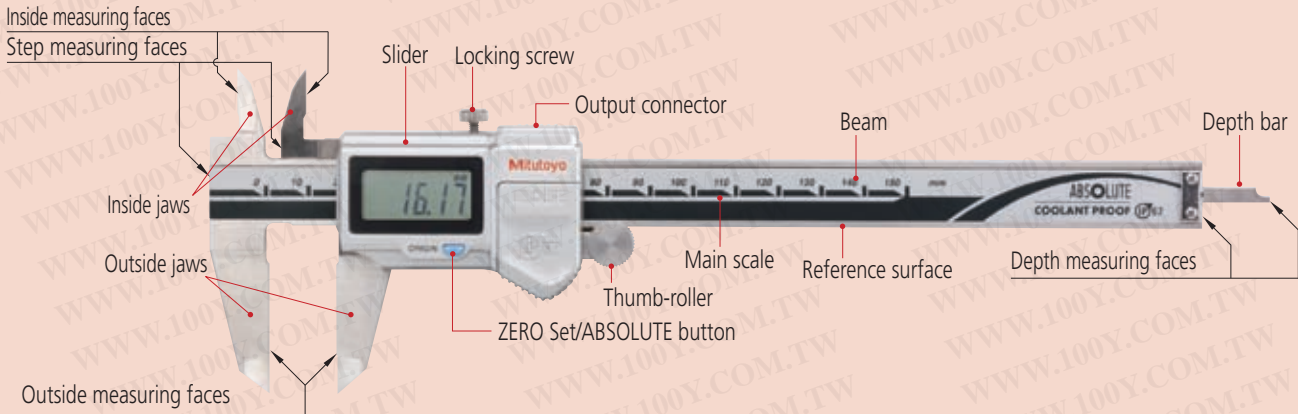

How to Read the Scale

● Vernier Calipers

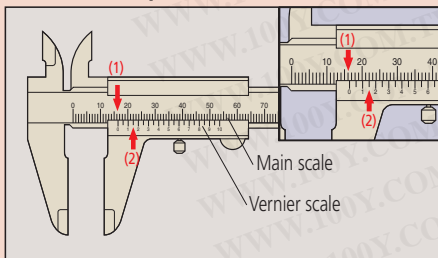

Graduation	0.05mm
(1) Main scale	16 mm
(2) Vernier	0.15 mm
Reading	16.15 mm

● Dial Calipers

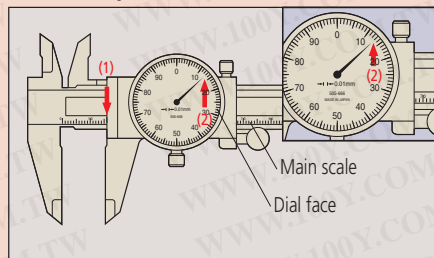

Graduation	0.01mm
(1) Main scale	16 mm
(2) Dial face	0.13 mm
Reading	16.13 mm

Note) Above left, 0.15 mm (2) is read at the position where a main scale graduation line corresponds with a vernier graduation line.

Measurement examples

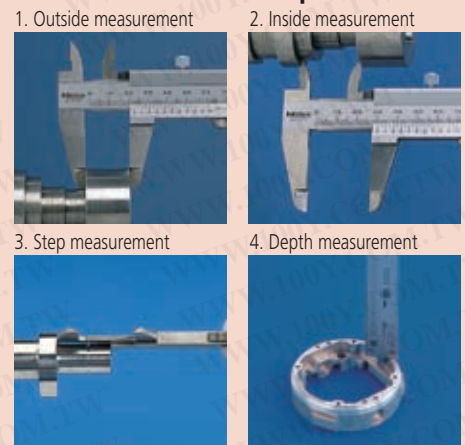

Special Purpose Caliper Applications

Point jaw type

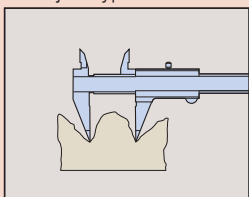

For uneven surface measurement

Offset jaw type

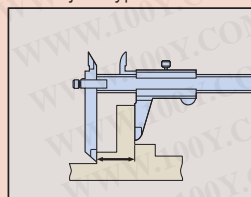

For stepped feature measurement

Depth type

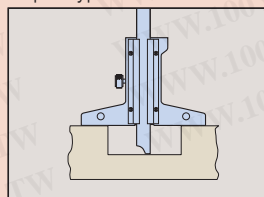

For depth measurement

Blade jaw type

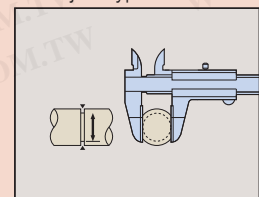

For diameter of narrow groove measurement

Vernier scale

This is a short auxiliary scale that enables accurate interpolation between the divisions of a longer scale without using mechanical magnification. The principle of operation is that each vernier scale division is slightly smaller than a main scale division, so that successive vernier graduations successively coincide with main scale graduations as one is moved relative to the other. Specifically, n divisions on a vernier scale are the same length as $n-1$ divisions on the main scale it works with, and n defines the division (or interpolation) ratio. Although n may be any number, in practice it is typically 10, 20, 25, etc., so that the division is a useful decimal fraction. The example below is for $n = 10$. The main scale is graduated in mm, and so the vernier scale is 9mm (10 divisions) long, the same as 9mm (9 divisions) on the main scale. This produces a difference in length of 0.1mm (1) as shown in figure A (the 1st vernier graduation is aligned with the first main scale graduation). If the vernier scale is slid 0.1mm to the right as shown in figure B, the 2nd graduation line on the vernier scale moves into alignment with the 2nd line on the main scale (2), and so enables easy reading of the 0.1mm displacement.

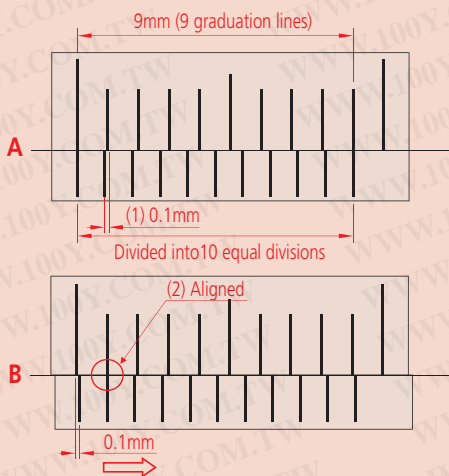

Some early calipers divided 19 divisions on the main scale by 20 vernier divisions to provide 0.05mm resolution. However, the closely spaced lines proved difficult to read and so, since the 1970s, a long vernier scale that uses 39 main scale divisions to spread the lines is generally used instead, as shown below.

19mm Vernier scale



39mm vernier scale (long vernier scale)

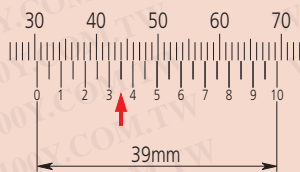

Calipers were made that gave an even finer resolution of 0.02mm. These required a 49-division vernier scale dividing 50 main scale divisions. However, they were difficult to read and are now hard to find since Digital calipers with an easily read display and resolution of 0.01mm appeared.

C-type

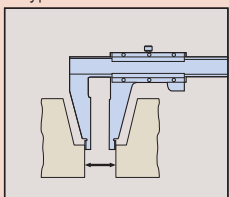

Standard outside measurement
Inside measurement of a stepped hole
Measurement of a stepped part

CN-type

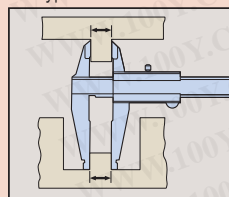

Standard outside measurement
Measurement of a stepped hole
Measurement of a stepped part

About Long Calipers

Steel rules are commonly used to roughly measure large workpieces but if a little more accuracy is needed then a long caliper is suitable for the job. A long caliper is very convenient for its user friendliness but does require some care in use. In the first place it is important to realize there is no relationship between resolution and accuracy. For details, refer to the values in our catalog. Resolution is constant whereas the accuracy obtainable varies dramatically according to how the caliper is used.

The measuring method with this instrument is a concern since distortion of the main beam causes a large amount of the measurement error, so accuracy will vary greatly depending on the method used for supporting the caliper at the time. Also, be careful not to use too much measuring force when using the outside measuring faces as they are furthest away from the main beam so errors will be at a maximum here. This precaution is also necessary when using the tips of the outside measuring faces of a long-jaw caliper.

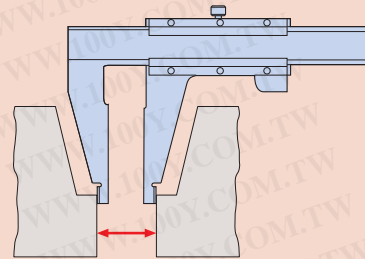

Small hole measurement with an M-type caliper

A structural error d occurs when you measure the internal diameter of a small hole.

$\varnothing D$: True internal diameter

$\varnothing d$: Measured diameter

t_1, t_2 : Thickness of the inside jaw

C : Distance between the inside jaws

Δd : Measurement error ($\varnothing D - \varnothing d$)

True internal diameter ($\varnothing D$: 5mm) Unit: mm

t_1+t_2+C	0.3	0.5	0.7
Δd	0.009	0.026	0.047

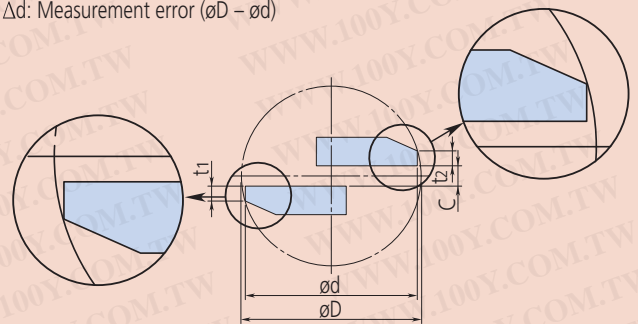

Inside Measurement with a CM-type Caliper

Because the inside measuring faces of a CM-type caliper are at the tips of the jaws the measuring face parallelism is heavily affected by measuring force, and this becomes a large factor in the measurement accuracy attainable. In contrast to an M-type caliper, a CM-type caliper cannot measure a very small hole diameter because it is limited to the size of the stepped jaws, although normally this is no inconvenience as it would be unusual to have to measure a very small hole with this type of caliper. Of course, the radius of curvature on the inside measuring faces is always small enough to allow correct hole diameter measurements right down to the lowest limit (jaw closure). Mitutoyo CM-type calipers are provided with an extra scale on the slider for inside measurements so they can be read directly without the need for calculation, just as for an outside measurement. This useful feature eliminates the possibility of error that occurs when having to add the inside-jaw-thickness correction on a single-scale caliper.

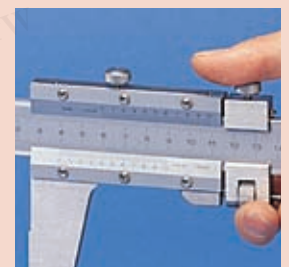
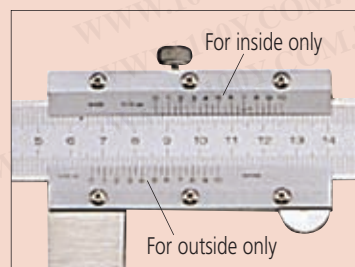

General notes on use of caliper

1. Potential causes of error

A variety of factors can cause errors when measuring with a caliper. Major factors include parallax effects, excessive measuring force due to the fact that a caliper does not conform to Abbe's Principle, differential thermal expansion due to a temperature difference between the caliper and workpiece, and the effect of the thickness of the knife-edge jaws and the clearance between these jaws during measurement of the diameter of a small hole. Although there are also other error factors such as graduation accuracy, reference edge straightness, main scale flatness on the main blade, and squareness of the jaws, these factors are included within the instrumental error tolerances. Therefore, these factors do not cause problems as long as the caliper satisfies the instrumental error tolerances. Handling notes have been added to the JIS so that consumers can appreciate the error factors caused by the structure of the caliper before use. These notes relate to the measuring force and stipulate that "as the caliper does not have a constant-force device, you must measure a workpiece with an appropriate even measuring force. Take extra care when you measure it with the root or tip of the jaw because a large error could occur in such cases."

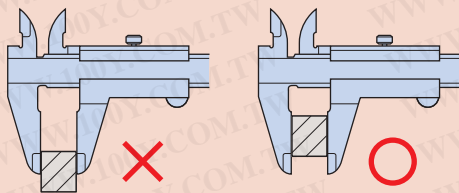
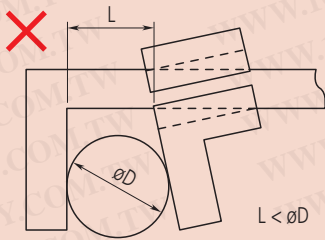

2. Inside measurement

Insert the inside jaw as deeply as possible before measurement.
 Read the maximum indicated value during inside measurement.
 Read the minimum indicated value during groove width measurement.

3. Depth measurement

Read the minimum indicated value during depth measurement.

4. Parallax error when reading the scales

Look straight at the vernier graduation line when checking the alignment of vernier graduation lines to the main scale graduation lines.
 If you look at a vernier graduation line from an oblique direction (A), the apparent alignment position is distorted by ΔX as shown in the figure below due to a parallax effect caused by the step height (H) between the planes of the vernier graduations and the main scale graduations, resulting in a reading error of the measured value. To avoid this error, the JIS stipulates that the step height should be no more than 0.3 mm.

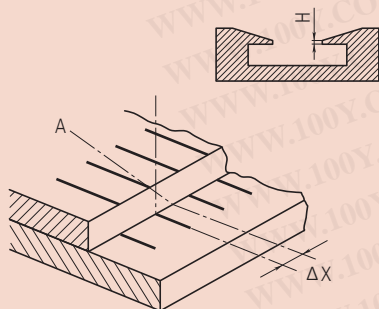

5. Moving Jaw Tilt Error

If the moving jaw becomes tilted out of parallel with the fixed jaw, either through excessive force being used on the slider or lack of straightness in the reference edge of the beam, a measurement error will occur as shown in the figure. This error may be substantial due to the fact that a caliper does not conform to Abbe's Principle.

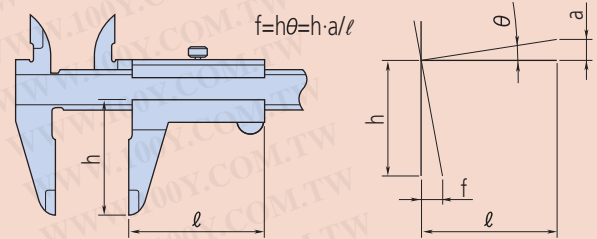

Example: Assume that the error slope of the jaws due to tilt of the slider is 0.01mm in 50mm and the outside measuring jaws are 40mm deep, then the error (at the jaw tip) is calculated as $(40/50) \times 0.01\text{mm} = 0.008\text{mm}$.
 If the guide face is worn then an error may be present even using the correct measuring force.

6. Relationship between measurement and temperature

The main scale of a caliper is engraved (or mounted on) stainless steel, and although the linear thermal expansion coefficient is equal to that of the most common workpiece material, steel, i.e. $(10.2 \pm 1) \times 10^{-6} / \text{K}$, note that other workpiece materials, the room temperature and the workpiece temperature may affect measurement accuracy.

7. Handling

Caliper jaws are sharp, and therefore the instrument must be handled with care to avoid personal injury.
 Avoid damaging the scale of a digital caliper and do not engrave an identification number or other information on it with an electric marker pen.
 Avoid damaging a caliper by subjecting it to impact with hard objects or by dropping it on a bench or the floor.

8. Maintenance of beam sliding surfaces and measuring faces

Wipe away dust and dirt from the sliding surfaces and measuring faces with a dry soft cloth before using the caliper.

9. Checking and setting the origin before use

Clean the measuring surfaces by gripping a sheet of clean paper between the outside jaws and then slowly pulling it out. Close the jaws and ensure that the vernier scale (or display) reads zero before using the caliper. When using a Digimatic caliper, reset the origin (ORIGIN button) after replacing the battery.

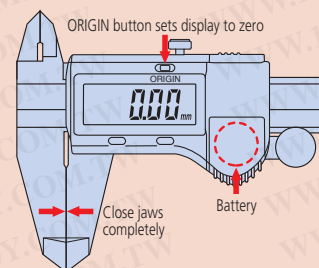

10. Handling after use

After using the caliper, completely wipe off any water and oil. Then, lightly apply anti-corrosion oil and let it dry before storage.
 Wipe off water from a waterproof caliper as well because it may also rust.

11. Notes on storage

Avoid direct sunlight, high temperatures, low temperatures, and high humidity during storage.
 If a digital caliper will not be used for more than three months, remove the battery before storage.
 Do not leave the jaws of a caliper completely closed during storage.