

DTC-EXL

ประแจปอนด์แบบดิจิตอล DATA PRINT-OUT DIGITAL TORQUE WRENCHES

Newly designed, features a multi-function digital read-out



FEATURES

- Accuracy : $\pm 1\%$ of indicated value + 1 increment, over the full range
- Display : torque reading 4-digit LCD display
- Measurement modes : ①Peak hold ②Peak to peak-hold ③Run
- Direction of measurement : Automatic CW/CCW changeover, provided with CW/CCW status display
- Power supply : two rechargeable "AA" 1.2V batteries and a 100-240V battery charger
- Battery life : Approximately 20 hours with fully charged batteries (continuous operation)
- Power off : Auto power-off, approximately 3 minutes 40 seconds
- Tolerance setting : Automatic judgement capability per the Min/Max settings
- Data memory : 100 pieces of data
- Output : Printer output (exclusively to a TPK-3), analog output $\ll 0$ to 1.024 (mid point) to 2.048 V \gg

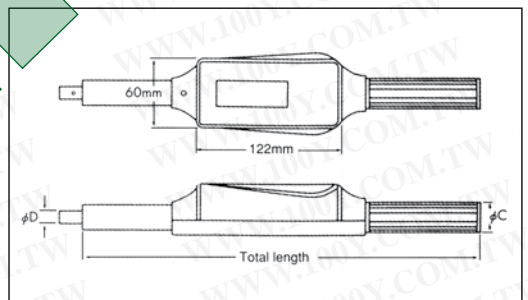

Model	Range (CW/CCW)	Increment	Total length (mm)	Ø D (mm)	Ø C (mm)	Weight (kg)	Accessory
DTC-100EXL	10~100 kgf-cm	0.1 kgf-cm	300	10	26	0.7	120 QCK
DTC-500EXL	50~500 kgf-cm	0.5 kgf-cm	324	12	26	0.7	450 QCK
DTC-1000EXL	100~1000 kgf-cm	1 kgf-cm	365	15	32	0.8	900 QCK
DTC-2000EXL	200~2000 kgf-cm	1 kgf-cm	380	18	32	0.9	1800 QCK
DTC-3000EXL	3~30 kgf-m	0.02 kgf-m	535	22	32	1.5	2800 QCK
DTC-5000EXL	5~50 kgf-m	0.05 kgf-m	1,063	30	34	3.9	7000 QCK
DTC-10000EXL	10~100 kgf-m	0.1 kgf-m	1,417	34	34	7.3	10000 QCK
DTC-N10EXL	1~10 N-m	0.01 N-m	300	10	26	0.7	120 QCK
DTC-N50EXL	5~50 N-m	0.05 N-m	324	12	26	0.7	450 QCK
DTC-N100EXL	10~100 N-m	0.1 N-m	365	15	32	0.8	900 QCK
DTC-N200EXL	20~200 N-m	0.1 N-m	380	18	32	0.9	1800 QCK
DTC-N300EXL	30~300 N-m	0.2 N-m	535	22	32	1.5	2800 QCK
DTC-N500EXL	50~500 N-m	0.5 N-m	1,063	30	34	3.9	7000 QCK
DTC-N1000EXL	100~1000 N-m	1 N-m	1,417	34	34	7.3	10000 QCK

DTDK-EXL

ประแจปอนด์ตามไขควงแบบดิจิตอล พร้อมจอแสดงผล
DIGITAL TORQUE DRIVER WITH CONNECTED DISPLAY

The display is separate from the driver. Complete tightening control for small screws.

FEATURES

- Accuracy : $\pm 1\%$ of indicated value + 1 increment, over the full range
- Display : torque reading 4-digit LCD display
- Measurement modes : ①Peak hold ②Peak to peak-hold ③Run
- Direction of measurement : Automatic CW/CCW changeover, provided with CW/CCW status display
- Power supply : two rechargeable "AA" 1.2V batteries and a 100-240V battery charger
- Battery life : Approximately 20 hours with fully charged batteries (continuous operation)
- Power off : Auto power-off, approximately 3 minutes 40 seconds
- Tolerance setting : Automatic judgement capability per the Min/Max settings
- Data memory : 100 pieces of data
- Output : Printer output (exclusively to a TPK-3), analog output << 0 to 1.024 (mid point) to 2.048 V>>

Model	Range (CW/CCW)	Increment	Weight (kg)
DTDK-20EXL	2~20 kgf.cm	0.01 kgf.cm	0.6
DTDK-50EXL	5~50 kgf.cm	0.05 kgf.cm	0.6
DTDK-N2EXL	20~200 cN.m	0.1 cN.m	0.6
DTDK-N5EXL	50~500 cN.m	0.5 cN.m	0.6

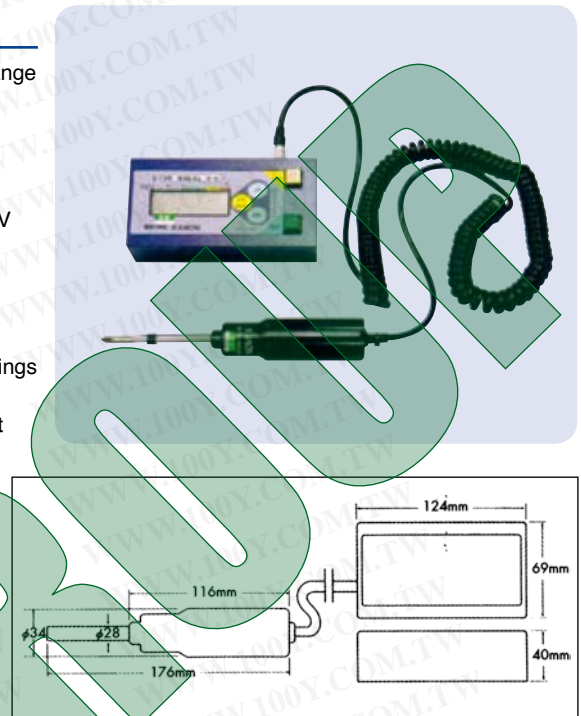

DTC-N5EXL

ประแจปอนด์แบบดิจิตอล พร้อมจอแสดงผล
DIGITAL TORQUE WRENCH WITH CONNECTED DISPLAY

The display is separate from the wrench. The slender wrench body facilitates measuring lower torques.

FEATURES

- Accuracy : $\pm 1\%$ of indicated value + 1 increment, over the full range
- Display : torque reading 4-digit LCD display
- Measurement modes : ①Peak hold ②Peak to peak-hold ③Run
- Direction of measurement : Automatic CW/CCW changeover, provided with CW/CCW status display
- Power supply : two rechargeable "AA" 1.2V batteries and a 100-240V battery charger
- Battery life : Approximately 20 hours with fully charged batteries (continuous operation)
- Power off : Auto power-off, approximately 3 minutes 40 seconds
- Tolerance setting : Automatic judgement capability per the Min/Max settings
- Data memory : 100 pieces of data
- Output : Printer output (exclusively to a TPK-3), analog output << 0 to 1.024 (mid point) to 2.048 V>>

Model	Range (CW/CCW)	Increment	Weight (kg)
DTC-50EXL	5~50 kgf.cm	0.05 kgf.cm	0.5
DTC-N5EXL	50~500 cN.m	0.5 cN.m	0.5

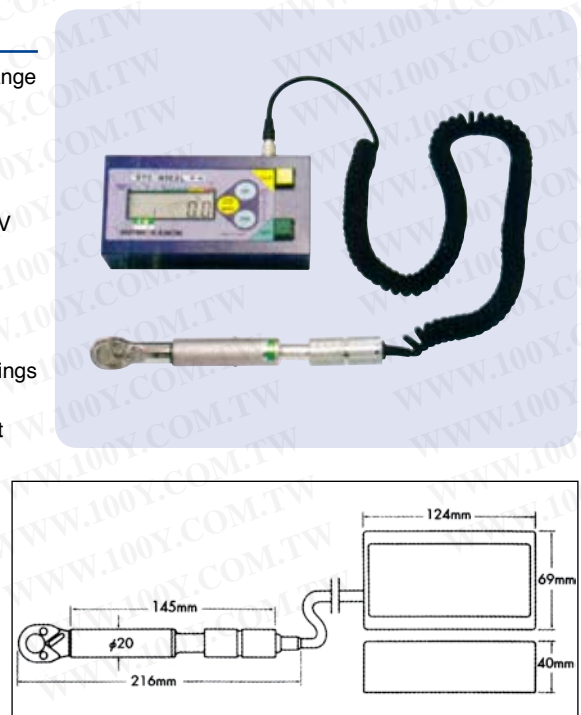

SPK

ประแจปอนด์หัวปากตายแบบตั้งแรงขันตายตัว PRE-SET TORQUE WRENCHES

Audible and tangible “CLICK” when the set torque is reached, assuring a securely tightened joint. This series is well-suited for production line use.

FEATURES

- A single function wrench, used for a single setting combination of fastener size and torque setting.
- Most suited for tightening multiple same-size fasteners at the same torque in a production line.
- Setting confirmation unnecessary.
- Can be used effectively in confined spaces.
- Tightening to set torque only in the direction of the arrow indicator, but can be used for general tightening in the other direction as well.
- Accuracy : ±3% of pre-set value

USING AN SPK WRENCH

With the wrench head completely engaging the fastener, and your grip centered on the groove in the wrench handle, pull the wrench in the direction indicated by the arrow on the wrench.

When the pre-set torque is reached, there will be an audible and tangible “click” and for a split second the wrench will suddenly require less force to pull.

Continuing to pull the wrench further will add torque over the setting.

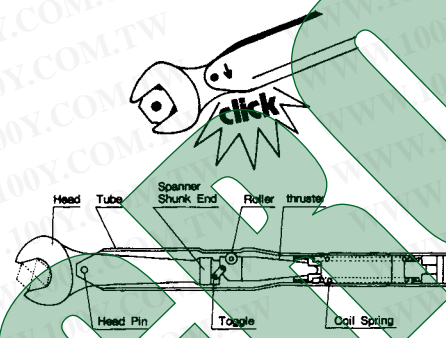
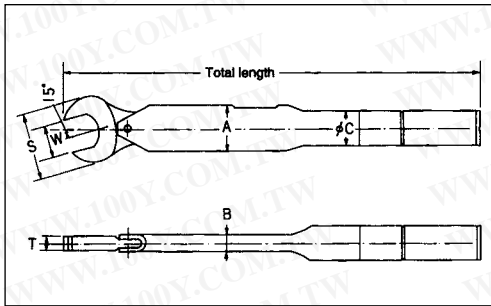
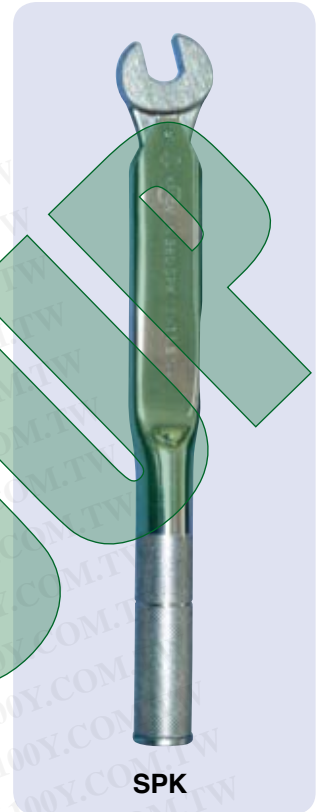

SPK Model	Range kgf.cm	N-SPK Model	Range N.m	Available sizes (W) mm				Total length mm	Dimensions (mm)					Weight (kg)	
				S	T	A	B		C						
30SPK	5~30	N30SPK	0.5~3	5.5	6			152	24	5	19.5	7.5	15	0.1	
80SPK	15~80	N80SPK	1.5~8	5.5	6	7		175	24	5	19.5	7.5	15	0.11	
190SPK	35~190	N190SPK	3.5~19	8	9	10	11	203	27	7	19.5	7.5	15	0.15	
				10	11	12	13	14	205						30
380SPK	80~380	N380SPK	8~38	17	19			213	35	8	26.6	8.2	20	0.29	
				10	11	12	13	14	248						35
670SPK	130~670	N670SPK	13~67	21	22	23	24	252	39	10	25.8	9.7	20	0.45	
				26	27	29	30	32	264						52
				14	17	19	21		319						45
				22	24	26			325						50
1200SPK	240~1,200	N1200SPK	24~120	27	30	32		330	56	11	32.8	11.3	25	0.46	
				36	41				342					65	0.47
				17	19	22			390					52	0.49
				24	26	27			397					57	0.75
1600SPK	300~1,600	N1600SPK	30~160	29	30	32		403	62	12	32.8	11.3	25	0.77	
				36	41				410					71	0.79
				19					436					53	0.81
				22	24	26			440					56	0.94
2200SPK	450~2,200	N2200SPK	45~220	27	30	32		449	64	14	32.8	11.3	25	0.97	
				36	41				457					73	1.1
				19	22				573					60	1.1
				24	27				579					65	1.2
3100SPK	650~3,100	N3100SPK	65~310	30	32	36		585	72	15	35.6	12.5	27.2	1.4	
				41					597					82	1.5
				22	24				650					67	1.3
				27	30	32			654					72	1.32
4200SPK	900~4,200	N4200SPK	90~420	36	41			662	82	16	38.0	16	30	1.4	
				24	27				833					74	1.45
				30	32				838					78	1.46
				36					843					82	1.47
				41					847					88	1.5
				46					860					94	1.52

RSPK

ประแจปอนด์หัวประแจแหวนแบบตั้งแรงขันตายตัว PRE-SET RING TORQUE WRENCHES

Can be used for accurate torque application even on joints inaccessible with other wrenches.

FEATURES

- Suited for joints not accessible with other wrenches
- A single function wrench, used for a single setting combination of fastener size and torque setting.
- Most suited for tightening multiple same-size fasteners at the same torque on a production line.
- Setting confirmation unnecessary.
- Accuracy : $\pm 3\%$ of pre-set value.

USING AN RSPK WRENCH

The ring head of RSPK wrenches is offset at a 45° angle making certain joints particularly accessible. With the wrench head completely engaging the fastener, pull the wrench handles in the direction indicated by the arrow on the wrench. When the pre-set torque is reached, there will be an audible and tangible "click" and for a split second the wrench will suddenly require less force to pull. Continuing to pull the wrench further will add torque over the setting. The inner mechanism is automatically reset when the wrench is disengaged from the fastener to go on to the next job.

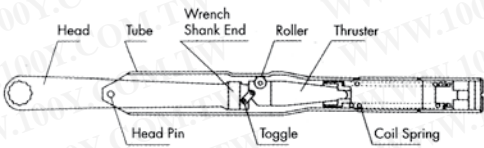
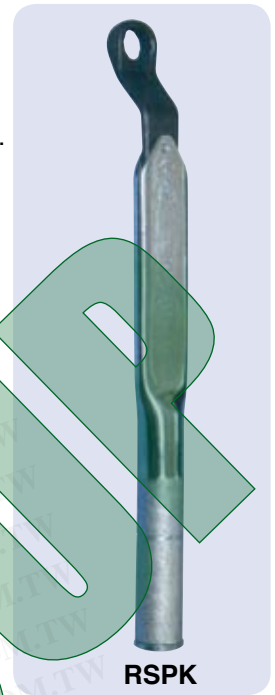

Model	★1			★2			★3				
	Available size (W)	Dimensions Head		Available size (W)	Dimensions Head		Available size (W)	Dimensions Head			
	mm	S	T	mm	S	T	mm	S	T		
30RSPK N30RSPK	5.5		4	80RSPK N80RSPK	5.5		4	190RSPK N190RSPK	10	16	7
	6	10	5		6	10	5		11	18	7
	7				7				12	19	8
	8	13	6		8	13	6		13	20	8.5
	9	14			9	14			14	22	9
	10	16	7	10	16	7	17	26	10		
				11	18	7	19	29	10.5		
				12	19	8	22	33	12		

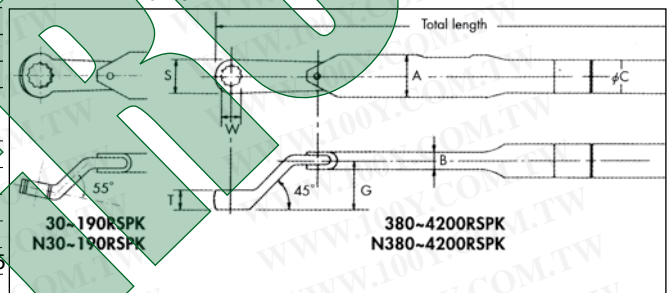

RSPK Model	Range kgf-cm	N-RSPK Model	Range N-m	Available sizes (W)				Total length mm	Dimensions (mm)					Weight (kg)	
				mm					Head		Body				
								S	T	G	A	B	C		
30RSPK	5~35	N30RSPK	0.5~3.5	5.5	6			175	★1			19.5	7.5	15	0.12
				7	8	9	10								
80RSPK	20~90	N80RSPK	2~9	5.5	6	7		197	★2			19.5	7.5	15	0.13
				8	9	10									
				11	12										
190RSPK	40~210	N190RSPK	4~21	10				222	★3			19.5	7.5	15	0.21
				11	12	13	14								
				17	19	22									
				11	12	13	14								
380RSPK	90~420	N380RSPK	9~42	17	19	22	14	268	22	10	25	26.6	8.2	20	0.31
				17	19	22									
670RSPK	140~730	N670RSPK	14~73	14	17			343	26	12	27	25.8	9.7	20	0.46
				19	22	24									
				27	30	32									
				19											
1200RSPK	250~1,270	N1200RSPK	25~127	19				413	32	13	29	32.8	11.3	25	0.8
				22	24										
				27	30	32									
				36											
1600RSPK	320~1,700	N1600RSPK	32~170	19	22	24		470	37	15	31	32.8	11.3	25	1.0
				27	30	32									
2200RSPK	480~2,300	N2200RSPK	48~230	19				605	37	16.5	33	35.6	12.5	27.2	1.25
				22	24	27									
				30	32										
				36											
3100RSPK	680~3,200	N3100RSPK	68~320	22				682	40	18	35	38	16	30	1.35
				24	27	30									
				32	36										
				41											
4200RSPK	950~4,300	N4200RSPK	95~430	27	30	32		880	52	37	43.3	17.8	34	1.55	
				36											
				41											
				46											

QLK

ประแจปอนด์แบบปรับตั้งแรงขัน หัวฟรีซ้าย-ขวา ADJUSTABLE, RATCHET TORQUE WRENCHES

Freely set torque values within the capacity range. Replaceable socket, ratchet wrenches.

FEATURES

- The ratchet improves efficiency. These wrenches are well suited for repetitive work.
- By replacing the sockets, various sizes of fasteners can be tightened within the tool's capacity range.
- By reversing the ratchet, the wrench can be used to loosen fasteners counter-clockwise.
- Tightening to a torque setting can only be done clockwise.
- Accuracy : ±3% of indicated value over the full range.

ADJUSTING THE TORQUE SETTING

◆ 30QLK~5600QLK

- (1) Loosen the lock screw. (See Fig. 1)
- (2) Turn the sub-scale and adjust to a torque value (the main scale plus the sub-scale) (See Fig 2)
- (3) Tighten the lock screw. (If the lock screw hits the pin before completely tightening, then change the position of the pin)

◆ 7000QLK~14000QLK

- (1) When applicable, mount the extension bar snugly all the way onto the body of the wrench
- (2) With the extension bar mounted (See Fig. 3) insert the hexagonal side of the adjusting box wrench
- Without the extension bar (See Fig. 4), insert the hexagonal side of the adjusting box wrench into the body.
- (3) Turn the adjusting box wrench to set the torque value. (the main scale plus the sub-scale)

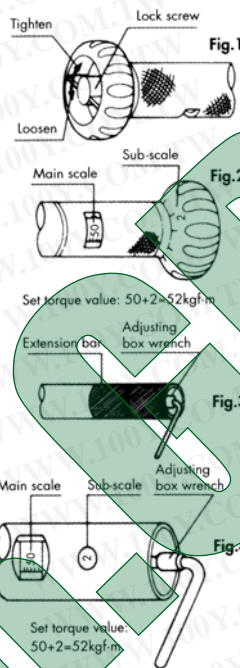

Model QLK	Range kgf-cm/kgf-m	Increment kgf-cm/kgf-m	Model N-QLK	Range cN-m/N-m	Increment cN-m/N-m	Square drive mm	Total length mm	Dimensions (mm)							Weight kg	Standard Accessory		
								Head			Body						Body length	
								H	G	R	A	B	C	D				
30QLK	10~30kgf-cm	0.5kgf-cm	N30QLK	100~300N-m	5 cN-m	6.35 (1/4")	186	18.8	7.5	12						0.18		
60QLK	20~60 "	1 "	N60QLK	20~80 N-m	0.1 "		231.5				18.2	9.6	15			0.27		
120QLK	40~120 "	2 "	N120QLK	4~12 "	0.2 "		240		11		15.5					0.29		
230QLK	70~230 "	2 "	N230QLK	7~23 "	0.2 "	9.35 (3/8")	253.5				16	25	11.4	20		0.45		
250QLK	50~250 "	2 "	N250QLK	5~25 "	0.2 "													
450QLK	100~450 "	5 "	N450QLK	10~45 "	0.5 "													
500QLK	100~500 "	5 "	N500QLK	10~50 "	0.5 "													
900QLK	200~900 "	10 "	N900QLK	20~90 "	1 "		352		31		19.5	27.5	12.4	21.7		0.69		
1000QLK	200~1000 "	10 "	N1000QLK	20~100 "	1 "	12.7 (1/2")	392											
1400QLK	400~1400 "	10 "	N1400QLK	40~140 "	1 "		478		33		23	34	15.4	27.2		1.45		
1800QLK	400~1800 "	20 "	N1800QLK	40~180 "	2 "													
2000QLK	400~2000 "	20 "	N2000QLK	40~200 "	2 "		678		42		23.5	35		30		1.9		
2800QLK	4~28 kgf-cm	0.2 kgf-cm	N2800QLK	40~280 "	2 "		950		42.7		27	38				3.3		
4200QLK	6~42 "	0.3 "	N4200QLK	60~420 "	3 "	19.05 (3/4")	1,195		49.5		34	43.5	18	34		5		
5600QLK	8~56 "	0.3 "	N5600QLK	80~560 "	3 "		1,388											
7000QLK	10~70 "	0.5 "	N7000QLK	100~700 "	5 "		1,315					49	20	38.1	30	955	7	
8500QLK	10~85 "	0.5 "	N8500QLK	100~850 "	5 "		1,538		58							995	8.5	
10000QLK	10~100 "	0.5 "	N10000QLK	100~1000 "	5 "		1,538									1,105	9.8	
14000QLK	20~140 "	1 "	N14000QLK	200~1400 "	10 "	25.4 (1")	1,844									1,144	14	
15000QLK	20~150 "	1 "	N15000QLK	200~1500 "	10 "		2,064									1,704	19.5	
21000QLK	70~210 "	1 "	N21000QLK	700~2100 "	10 "													Torque adjusting box wrench

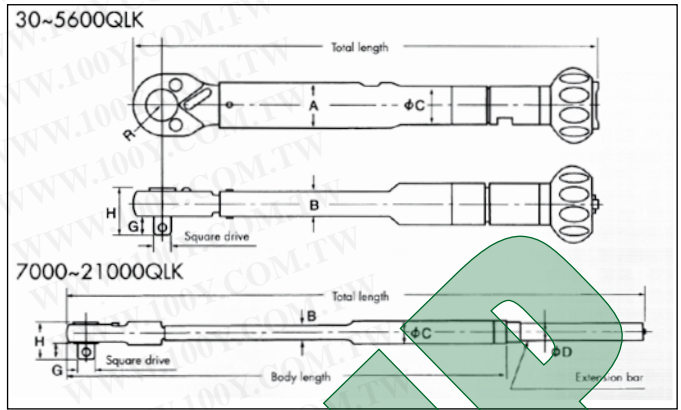
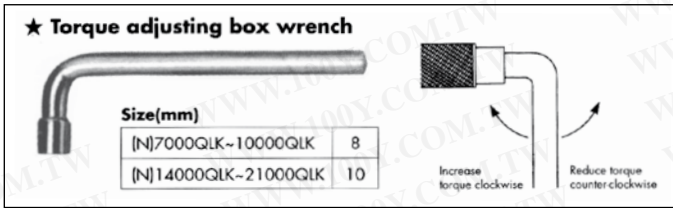

QSPK

ประแจปอนด์แบบปรับตั้งแรงขันตายตัว หัวฟรีซ้าย-ขวา PRE-SET, RATCHET TORQUE WRENCHES

Pre-set torque value. Improved work efficiency with ratchet square drive.

FEATURES

- The ratchet drive enables quickly tightening fasteners to the preset torque. Suitable for repetitive jobs.
- The wrench's inner mechanism automatically resets itself for the next job after disengaging from a tightened joint.
- Accuracy: $\pm 3\%$ of set value.

RE-SETTING THE PRE-SET TORQUE

(SPK • RSPK • QSPK • SPKC • TYPES)

- (1) Remove the screw cap with a slot drive screw driver.
- (2) Loosen the setting screw with a hex wrench.
- (3) Using the special adjusting tool or equivalent, rotate the slotted plate clockwise to increase torque or counterclockwise to reduce torque. Check the setting with a torque analyzer.

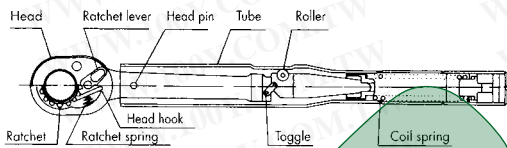

Setting screw

★ Adjusting tools

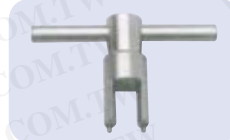

- (4) Tighten the setting screw with a hex wrench.
- (5) Screw on the screws cap and tighten it.

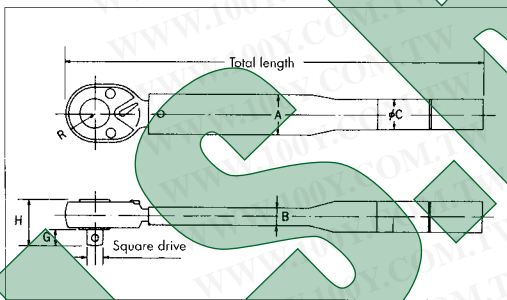

Model	APPLICABLE TORQUE WRENCH
Adjusting Tool No.1	(N)30,80,190SPK, (N)30,80,190RSPK, (N)60,120,230QSPK
Adjusting Tool No.2	(N)380,670SPK, (N)380,670RSPK, (N)450,500,900,1000,1400QSPK
Adjusting Tool No.3	(N)1200,1600,2200SPK, (N)1200,1600,2200RSPK, (N)1800,2000QSPK
Adjusting Tool No.4	(N)3100SPK, (N)3100RSPK, (N)2800QSPK
Adjusting Tool No.5	(N)4200SPK, (N)4200RSPK, (N)4200QSPK

*Adjusting tool is option.

Model QSPK	Range kgf-cm	Model N-QSPK	Range N-m	Square drive mm	Total length mm	Dimensions (mm)						Weight kg
						Head			Body			
						H	G	R	A	B	C	
60QSPK	20~60	N 60QSPK	2~6	6.35(1/4")	174	19.5	7.5	12.5	18.2	9.6	15	0.17
120QSPK	40~120	N 120QSPK	4~12									
230QSPK	70~230	N 230QSPK	7~23	9.53(3/8")	220	25	12	16	25	11.4	20	0.25
250QSPK	70~250	N 250QSPK	7~25									
450QSPK	100~450	N 450QSPK	10~45	12.7(1/2")	240	31	14	19.5	27.5	12.4	21.7	0.38
500QSPK	100~500	N 500QSPK	10~50									
900QSPK	200~900	N 900QSPK	20~90	19.05(3/4")	340	41	20	26	38	16	30	0.64
1000QSPK	200~1000	N 1000QSPK	20~100									
1400QSPK	400~1400	N 1400QSPK	40~140	670	380	49.5	20	34	43.5	16	34	0.7
1800QSPK	400~1800	N 1800QSPK	40~180									
2000QSPK	400~2000	N 2000QSPK	40~200	980	463.5	41	20	26	38	16	30	1.35
2800QSPK	600~2800	N 2800QSPK	60~280									
4200QSPK	600~4200	N 4200QSPK	60~420									2.3
												4.3

LCK

ประแจปอนด์แบบปรับตั้งแรงขัน เปลี่ยนหัวขันได้ ADJUSTABLE, REPLACEABLE HEAD TORQUE WRENCHES

Freely replace heads according to work applications. The combination of replaceable heads and torque adjustability make this series extremely versatile.

FEATURES

- Ring, ratchet, open end wrench and hex drive heads are available.
- The torque can be set to any value within the capacity range.
- Models are available ranging from 20 kgf-cm to 14,000 kgf-cm.
- Accuracy : ±3% of indicated value over the full range.

ADJUSTING THE TORQUE SETTING

■ 60LCK~5600LCK

- (1) Loosen the lock screw. (See Fig.1)
- (2) Turn the sub-scale and adjust to a torque value. (the main scale plus the subscale) (See Fig. 2)
- (3) Tighten the lock screw. (If the lock screw hits the pin before completely tightening, then change the position of the pin)

■ 7000LCK-14,000LCK

- (1) When applicable, mount the extension bar snugly all the way onto the body of the wrench.
- (2) With the extension bar mounted (See Fig.3), insert the hexagonal end of the adjusting box wrench.
- Without the extension bar (See Fig.4), insert the hexagonal end of the adjusting box wrench into the body.
- (3) Turn the adjusting box wrench to set the torque value. (Add the sub-scale to the main scale.)

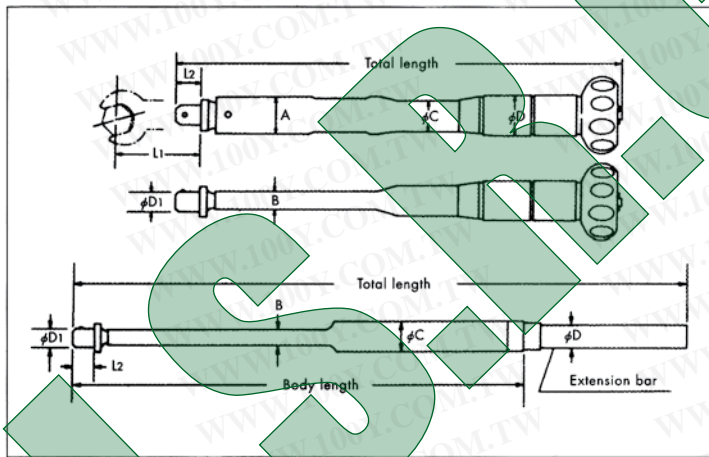
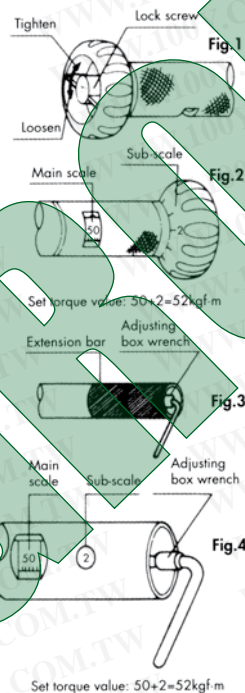

LCK Model	Range kgf-cm/kgf-m	Increment kgf-cm/kgf-m	N-LCK Model	Range N-m	Increment N-m	Total length mm	Dimensions (mm)							Weight kg	Replaceable heads	
							Head			Body						Body length
							φD1	L1	L2	A	B	C	D			
60LCK	20-60	1	N60LCK	2-6	0.1	173	10	45	13	18.2	9.6	15			0.17	120QCK,230 { SCK, RCK, HCK
120LCK	40-120	2	N120LCK	4~12	0.2											
230LCK	70-230	2	N230LCK	7~23	0.2											
450LCK	100-450	5	N450LCK	10~45	0.5	232	12	55	16	25	11.4	20			0.36	450 (QCK, SCK, RCK, HCK)
900LCK	200-900	10	N900LCK	20~90	1	325	15	6	18	27.5	12.4	21.7			0.59	900 (QCK, SCK, RCK, HCK)
1800LCK	400-1800	20	N1800LCK	40~180	2	443	18	80	22	34	15.2	27.2			1.3	1800 (QCK, SCK, RCK, HCK)
2800LCK	4-28	0.2	N2800LCK	40~280	2	640	22	100	27	38	16	30			2.1	2800 (QCK, SCK, RCK, HCK)
4400LCK	6-44	0.3	N4400LCK	60~420	3	908									3.2	4200 (QCK, SCK, RCK, HCK)
5600LCK	8-56	0.3	N5600LCK	80~560	3	1086				43.5	18	34			4.9	7000 (QCK, SCK, RCK)
7000LCK	10-70	0.5	N7000LCK	100~700	5	1206	30	125	45	49	20	38.1	30	840	6.9	
8500LCK	10-85	0.5	N8500LCK	100~850	5	1267								874	7.5	10000 (QCK, SCK, RCK)
10000LCK	10-100	0.5	N10000LCK	100~1000	5	1417	34	130	47	54	23	42.7	31.8	887	9.3	
14000LCK	20-140	1	N14000LCK	200~1400	10	1700	38	160	60	66	26	50.8	40	1003	13.5	14000 (QCK, SCK, RCK)

HEADS

หัวประแจต่อตามประเภทปอนด์ OPTIONAL REPLACEABLE HEADS

SCK(Open End head)

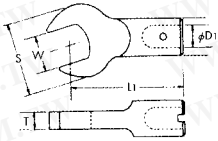

RCK(Ring head)

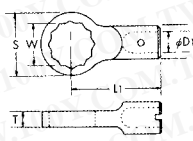

QCK(Ratchet head)

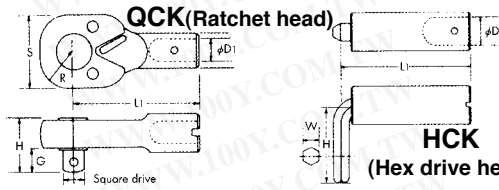

HCK

(Hex drive head)

■ SCK open end heads

HYK Model	Size (W)				S	T	L1	øD1	Applicable torque wrench		
	7	8	9	10					(N)60-230LCK (N)60-250SPCK (N)250FCK DTC-50EXL DTC-100EXL	DTC-P140EXL DTC-P180EXL DTC-N5EXL DTC-N10EXL	
230SCK	7	8	9	10	29	7	45	10			
	11				32						
	12	13	14		39	8					
	17	19	21	22	45						
450SCK	8	9	10	11	32	8	55	12			
	12	13	14		36						
	17	19	21	22	44	10					
	24	27			50						
900SCK	12	13	14		40	10	65	15			
	17	19	21	22	48	12					
	24	27	30		57						
	32	36	41		75						
1800SCK	17	19	21	22	56	14	80	18			
	24	27	30		64						
	32	36	41		75						
	19	21			59						
2800SCK	21	22			61	16	100	22			
	24				63						
	27				67						
	30				69	16.5					
	32				71						
	36				75	18					
	41				80	20					
	46				85						
4200SCK	27				71	25	125	25			
	30				74						
	32				76						
	36				79						
	41				84						
	46				90						
	50				94						
	55				97						28
60				100	30						
4400SCK	19	22	24		70	20	100	22			
	27	30	32		78						
	36	41			84						
	46	50			94						22
	55	60			100						25
	27				83						
7000SCK	30				86	25	125	30			
	32				88						
	36				91						
	41				95						28
	46				98						
	50				102						30
	55				105						
	60				110						
10000SCK	36				95	32	130	34			
	41				100						
	46				106						
	50				110						
	55				115						32
	60				120						
14000SCK	41				110	35	160	38			
	46				115						
	50				120						
	55				122						
	60				127						
65				130							

■ RCK ring heads

RCK Model	Size (W)				S	T	L1	øD1	Applicable torque wrench		
	7	8	9	10					(N)60-230LCK (N)60-250SPCK (N)250FCK DTC-50EXL DTC-100EXL	DTC-P140EXL DTC-P180EXL DTC-N5EXL DTC-N10EXL	
230RCK	7	8	9	10	18	8	45	10			
	11				21						
	12	13	14		24	31					
	17	19	22	24	31						
450RCK	8	9	10	11	19	10	55	12			
	11	12	13	14	19						
	17	19	22		32						
	12	13	14		25						
900RCK	17	19	21	22	34	13	65	15			
	24	27	30		42						
	17	19	22		35						
	24	27	30		45	15					
1800RCK	32	36	41		58	15	80	18			
	17	19	22		35						
	24	27	30		45						
	27	30	32		47	17					
2800RCK	27	30	32		57	20	100	22			
	36	41			63						
	46				70						
	27	30	32		57	20					
4200RCK	36				58	20	125	25			
	41				63						
	46	50			68	23					
	55	60			78						
4400RCK	19	22	24		44	20	100	22			
	27	30	32		50						
	36	41			58						
	46	50			66						
7000RCK	27	30	32		57	20	125	30			
	36				62						
	41				62						
	46	50			70	25					
10000RCK	41				62	30	130	34			
	46				65						
	50				72	30					
	55				80	33					
	60				80						
	36				65	25					
14000RCK	41				75	27	160	38			
	46				80	30					
	50				80	32					
	55				90	35					
	60				90						
	65				90						

■ HCK hex drive heads

HCK Model	Size (W) Size (H)		L1	øD1	Applicable torque wrench	
230RCK	2.5	19			45	10
	3	22				
	4	25				
	5	30				
	6	35				
450RCK	4	27	55	12	(N)450LCK (N)450-500SPCK (N)500FCK DTC-500EXL	DTC-P1400EXL DTC-N50EXL
	5	30				
	6	35				
	8	40				
	10	45				
900RCK	6	35	65	15	(N)900LCK (N)900-1000SPCK (N)1000FCK DTC-1000EXL	DTC-P1800EXL DTC-N100EXL
	8	40				
	10	45				
	12	51				
	14	63				
1800RCK	8	40	80	18	(N)1800LCK (N)1800-2000SPCK (N)1500FCK DTC-2000EXL	DTC-PF100EXL DTC-N200EXL
	10	45				
	12	51				
	14	63				
	17	72				
2800RCK	12	51	100	22	(N)2800LCK SPCK (N)2300FCK DTC-3000EXL	DTC-PF200EXL DTC-N300EXL
	14	63				
	17	71				
	19	80				

■ QCK ratchet heads

QYK Model	Sq. drive	S	H	G	R	L1	øD1	Applicable torque wrench	
1200QCM	6.35 (1/4")	24	19	7.5	12	45	10	(N)60-230LCK (N)60-250SPCK (N)250FCK, 50EXL, 100EXL	DTC-P140EXL DTC-P180EXL DTC-N5EXL DTC-N10EXL
2300QCM	9.53 (3/8")	31	25	11	15.5	55	12	(N)450LCK, (N)450-500SPCK (N)500FCK, DTC-500EXL	DTC-P1400EXL DTC-N50EXL
4500QCM	12.7 (1/2")	39	31	14	19.5	65	15	(N)900LCK, (N)900-1000SPCK (N)1000FCK, DTC-1000EXL	DTC-P1800EXL DTC-N100EXL
9000QCM	12.7 (1/2")	46	33	14	23	80	18	(N)1800LCK, (N)1800-2000SPCK (N)1500FCK, DTC-2000EXL	DTC-PF100EXL DTC-N200EXL
2800QCM	19.5 (3/4")	52	41	20	26	100	22	(N)2800LCK SPCK (N)2300FCK, DTC-3000EXL	DTC-PF200EXL DTC-N300EXL
4200QCM	19.5 (3/4")	68	50	20	34	125	25	(N)4200LCK, (N)4200SPCK	
4400QCM	19.5 (3/4")	54	42.5	20	27	100	22	(N)4400LCK, (N)4400SPCK	
7000QCM	25.4 (1")	68	50	27	34	125	30	(N)7000FCK, DTC-5000EXL	DTC-PF400EXL DTC-N500EXL
10000QCM	25.4 (1")	76	58	27	38	130	34	(N)8500LCK, (N)8500SPCK (N)10000FCK, DTC-5000EXL	DTC-PF800EXL DTC-N1000EXL
14000QCM	25.4 (1")	87	61	27	43.5	160	38	(N)14000LCK	

HYK

ประแจปอนด์แบบปรับตั้งแรงขัน หัวประแจเลื่อน

ADJUSTABLE WRENCH HEADS, ADJUSTABLE TORQUE WRENCH

Built-in "no play" worm screw



FEATURES

- Since the head can be taken off and reversed, the wrench can be used in confined spaces (in as small as a 30 degree turn) previously inaccessible to even other adjustable wrenches. (Tightening to a torque setting can only be done in the direction of the arrow.)
- There is hardly any play in the worm screw adjuster in the wrench head, which will improve your working efficiency. Without excess play, the torque wrench will not damage the corners of fasteners like ordinary wrenches will.
- Accuracy : $\pm 4\%$ of indicated value over the full range

USING AN HYK

Setting the opening

- (1) Slide the jaws onto the fastener until it contacts the spring pin. (a)
- (2) Tighten the adjusting worm screw so the jaws grip the fastener. (b)
- (3) Loosen the adjusting worm screw just enough to allow removing the wrench from the fastener. (c)

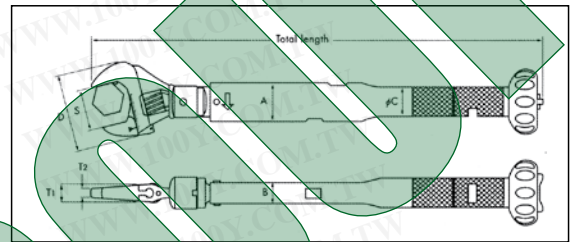
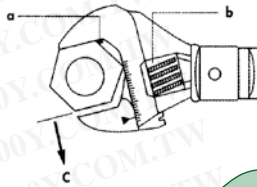

HYK Model	Range kgf-cm	Increment kgf-cm	N-HYK Model	Range N-m	Increment N-m	Total length mm	Opening Size (mm)	Dimensions (mm)						Weight kg
								Head			Body			
450HYK	100~450	5	N450HYK	10~45	0.5	285	10~25	D	T ₁	T ₂	A	B	øC	øD
9000HYK	200~900	10	N9000HYK	20~90	1.0	386	10~30	58	12	6.5	27.5	12.4	21.7	
1800HYK	400~1800	20	N1800HYK	40~180	2.0	518	17~38	66	12.5	6.5	34	15.4	27.2	1,420

QLK-LR

ประแจปอนด์แบบปรับตั้งแรงขัน

LARGE HUB NUT TORQUE WRENCHES

Idea for tightening hub nuts on large trucks and buses



FEATURES

- Dual squares drives for both clockwise and anticlockwise tightening.
- By replacing the sockets, various size of fasteners can be tightened within the tool's capacity range
- By reversing the switch on the wrench can be used to loosen fasteners. Tightening to a torque, setting, however, can only be done in the direction of the arrow.
- Accuracy : $\pm 3\%$ of indicated value over the full range

USING A QLK-LR WRENCH

- (1) When applicable, mount the extension bar snugly all the way onto the body of the wrench.
- (2) With the extension bar mounted (See Fig.1) insert the hexagonal end of the adjusting box wrench
- Without the extension bar (See Fig.2), insert the hexagonal end of the adjusting box wrench into the body.
- (3) Turn the adjusting box wrench to set the torque value.
(Add the sub-scale to the main scale.)

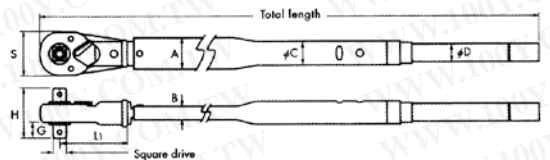
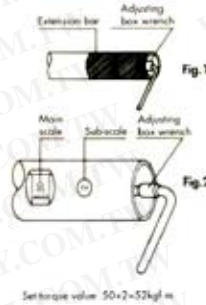

QCK-LR Model	Applicable torque wrench	Square drive
		mm
7000QCK-LR	(N) 5600~7000LCK	19.05(3/4")
8500QCK-LR	(N) 8500~10000LCK	25.4(1")

QLK-LR Model	Range kgf-m	Increment	N-QLK-LR Model	Range N-m	Increment	Square drive mm	Total length mm	Dimensions (mm)						Weight kg	Standard Accessory		
								Head			Body						
7000QLK-LR	10~70	0.5	N7000QLK-LR	100~700	5	19.05(3/4")	1,315	S	G	H	L ₁	A	B	øC	øD	7	Torque adjusting box wrench
8500QLK-LR	10~85		N8500QLK-LR	100~850		1,318	76	27	85	168	54	23	42.7	31.8	8.5		
10000QLK-LR	10~100		N10000QLK-LR	100~1000		1,538									9.8		

FK ประแจปอนด์แบบเข็ม INDICATOR PLATE TORQUE WRENCHES

Quite suitable for general tightening and for checking torque on previously tightened joints. A popular series with fan-shaped indicator plate scales

FEATURES

- The simple structure and small friction area give this series of tools a long life.
- Strong and easy to handle
- Accuracy $\pm 3\%$ of indicated value over the full range

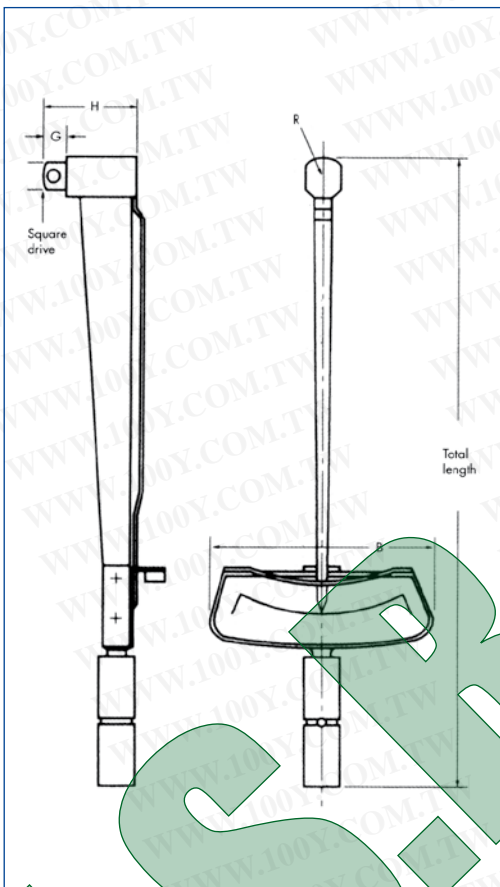

FK

Model FK	Range (CW/CCW) kgf-cm	Increment	Model N-FK	Range (CW/CCW) cN-m/N-m	Increment	Sq. drive mm	Total length mm	Dimensions (mm)				Weight kg	
								Head		Body			
								H	G	R	B		
4FK	1~4	0.2	N4FK	10~40	2 cN-m	6.35 (1/4")	110	26	7.5	5	54	0.05	
7FK	1~7	0.2	N7FK	10~70	2 "		132					0.05	
15FK	5~15	0.5	N15FK	50~150	5 "		140					0.08	
30FK	10~30	1	N30FK	1~3	N-m		0.1 N-m					170	0.1
60FK	10~60	2	N60FK	1~6	"		0.2 "					190	0.22
120FK	20~120	5	N120FK	2~12	"	0.5 "	237	43	7.5	6	85	0.25	
230FK	30~230	5	N230FK	3~23	"	0.5 "	290	44	11	9	106	0.3	
450FK	50~450	10	N450FK	5~45	"	1 "	320	45	11			0.34	
900FK	100~900	20	N900FK	10~90	"	2 "	388			12.5		1.1	
1300FK	200~1,300	20	N1300FK	20~130	"	2 "	441	60	14	13.5	114	1.2	
1800FK	300~1,800	50	N1800FK	30~180	"	5 "	487					1.3	
2800FK	500~2,800	50	N2800FK	50~280	"	5 "	597	82	20	15	124	2.6	
4200FK	700~4,200	100	N4200FK	70~420	"	10 "	853	48	20	28	186	3.5	
5600FK	1,000~5,600	100	N5600FK	100~560	"	10 "	946					31	4.4
7000FK	1,000~7,000	100	N7000FK	100~700	"	10 "	1172					32	6.7
8500FK	1,500~8,500	200	N8500FK	150~850	"	20 "	1387					37	8.0
10000FK	2,000~10,000	200	N10000FK	200~1,000	"	20 "	1578					43	13.3
15000FK	3,000~15,000	200	N15000FK	300~1,500	"	20 "	1973	76.5	27	43	241	17.0	

TMK ประเทศไทย 2 เซ็ม DIAL INDICATOR TORQUE WRENCHES

Easy to read dial indicator
Well suited for inspection and general maintenance service.



FEATURES

- Both peak and standard indicator typer are available.
- Easily readable for inspections.
- Useful for inghtening work.
- Accuracy :±3% of indicated value over the full range

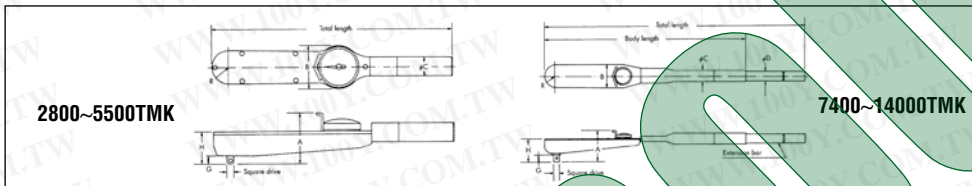

TMK Model	Range (CW/CCW) kgf-m	Increment	M-TMK Model	Range (CW/CCW) N-m	Increment	Sq. drive mm	Total length mm	Dimensions (mm)						Body length	Weight kg		
								Head		Body							
								H	G	R	A	B	C	D			
2800TMK	3-28	0.5	N2800TMK	30-280	5	12.7 (1/2")	680					80					1.3
4000TMK	4-40	1	N4000TMK	40-400		19.05 (3/4")	900										2.2
5500TMK	5-55	1	N5500TMK	50-550	10		1100	77	21	35							2.6
7000TMK	7-70	1	N7000TMK	70-700			1270									765	6.6
8500TMK	10-85	1	N8500TMK	100-850		25.4 (1")	1400										7.2
10000TMK	10-100	2	N10000TMK	100-1000	20		1560	87	27	40		91	40	32			7.8
14000TMK	20-140	2	N14000TMK	200-1400			1600									895	8.5

TOK ประเทศไทย 2 เซ็ม DIAL INDICATOR TORQUE WRENCHES

Easy to read dial indicator
Well suited for inspection and general maintenance service.



FEATURES

- Oval design with comfort rubber grip reduces strain
- Easily readable for inspections.
- Useful for tightening work.
- Accuracy :±3% of indicated value over the full range

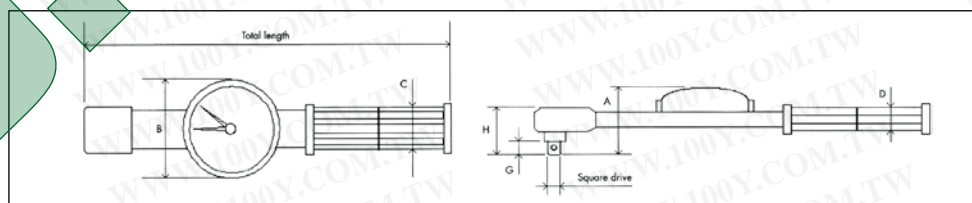

Model	Range (CW/CCW) kgf-m	Increment	Model	Range (CW/CCW) N-m	Increment	Square drive mm	Total length mm	Dimensions (mm)						Weight g	
								Head		Body					
								H	G	A	B	C	D		
60TOK	6-60	1	N6TOK	0.6-6	0.1	6.35 (1/4")	260	38.5	7.5	56					504
120TOK	10-120	2	N12TOK	1-12	0.2										508
300TOK	50-300	5	N30TOK	5-30	0.5	9.53 (3/8")	323	43	11	58	68		37	21.5	614
700TOK	100-700	10	N70TOK	10-70	1										
1400TOK	200-1400	20	N140TOK	20-140	2	12.7 (1/2")	463	49	14	63			41	22.5	865
2000TOK	200-2000	20	N200TOK	20-200	2										

LTDK ประแจปอนด์ด้ามไขควง CLUTCH RELEASE TORQUE SCREW DRIVERS

Clutch release prevents over-tightening, reduces fatigue.

FEATURES

- Comfortable grip for extended use.
- Light weight and short overall length facilitates jobs.
Sensitive clutch release helps the operator feel when the torque setting is reached.
- Set the required torque value and tighten, all operators tighten consistently.
- Two Phillips bit are included.
- Various hex and box drive bits are available.
- Use for both clockwise and counter-clockwise tightening.
- Accuracy $\pm 3\%$ of indicated value over the full range, clockwise.
- “-H” models accept standard bits instead of CB type bits.

USING AN LTK DRIVER

- (1) Select and mount a bit to match the fastener
- (2) Rotate the adjusting ring and set the desired torque.
- (3) Tighten the fastener clock-wise until the clutch releases and there is no more resistance.

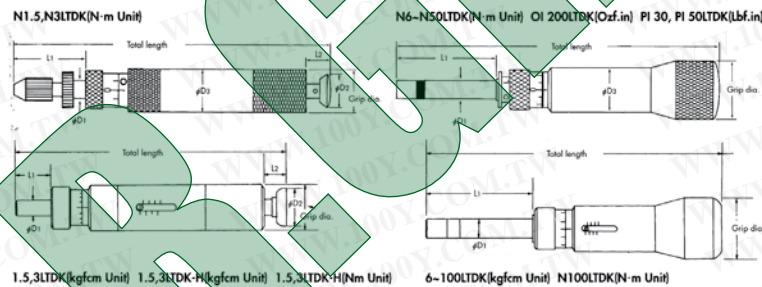
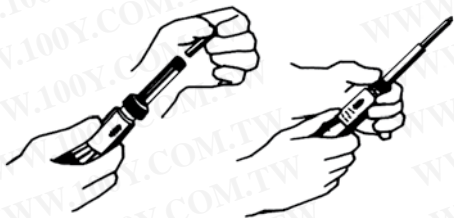

Model	Range	Increment	Grip dia.	Total length (without bit)	Dimensions (mm)					Weight	Attachment Bits		
					Body						Bits		
N-LTK	cN·m/N·m		ømm	mm	L1	L2	øD1	øD2	øD3	g	Phillips	Bit type	
N1.5LTK	1~15	0.1	16	107	22	10.5	5.5	14.4	16	57	No.0	KANON bits	
N3LTK	2~30	0.2	16	107	22	10.5	5.5	14.4	16	57	No.1		CB type
N6LTK	5~60	0.5	25	110	26				20	99	No.0	Standard bits	
N12LTK	20~120	1	30	157	51		10		25	192	No.1		SB type
N20LTK	40~200	1	34	157	51		10		25	214	No.1		
N30LTK	40~300	1	34	157	51		10		25	214	No.1		
N50LTK	100~500	2.5	40	200	63				34	436	No.2	Standard bits	
N100LTK	4~10	0.05	45	235	100		11		35	762	No.2, No.3		SB type

Model	Range	Increment	Grip dia.	Total length (without bit)	Dimensions (mm)					Weight	Attachment Bits		
					Body						Bits		
N-LTK	kgf·cm/cN·m		ømm	mm	L1	L2	øD1	øD2	øD3	g	Phillips	Bit type	
1.5LTK	0.1~1.5	0.01	16	99	14	9	5.5	14.4		50	No.0	KANON bits	
3LTK	0.2~3	0.02	16	99	14	9	5.5	14.4		50	No.1		OB type
6LTK	0.5~6	0.05	25	110	35				20	95	No.0	Standard bits	
12LTK	2~12	0.1	30	157	57		10		25	190	No.1		SB type
20LTK	4~20	0.1	34	157	57		10		25	208	No.1		
30LTK	4~30	0.1	34	157	57		10		25	208	No.1		
50LTK	10~50	0.25	40	200	73				34	436	No.2	Standard bits	
100LTK	40~100	0.5	45	235	100		11		35	762	No.2, No.3		SB type
1.5LTK-H	0.1~1.5	0.01	16	111	26	9	10	14.4	35	60	No.0	Standard bits	
3LTK-H	0.2~3	0.02	16	111	26	9	10	14.4	35	60	No.0		
N1.5LTK-H	1~15	0.1	16	111	26	9	10	14.4	35	60	No.1		
N3LTK-H	2~30	0.2	16	111	26	9	10	14.4	35	60	No.1		

DPSK ประเภทปอนด์แบบเข็มดำมีไขควง DIAL GAUGE TORQUE DRIVERS

Suited for light torque, general tightening work, inspections and break tests. Easy to handle, easy to read scale.



FEATURES

■ DPSK (standard)

- A light torque driver well suited for general tightening, inspections and break tests.
- Easy handling with a direct reading dial gauge.
- Use for both clockwise and counterclockwise tightening.
- Peak torque indicator works in both directions, too.
- Large, easily read dial gauge.

■ DPSK II (transparent scale)

- The transparent scale makes engaging the fastener easier.
- For both models, accuracy is $\pm 3\%$ of the indicated value over the full range

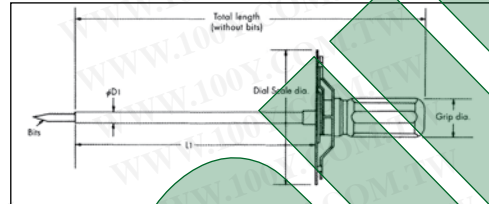

Model DPSK	Range (CW/CCW)	Increment	Model N-DPSK	Range (CW/CCW)	Increment	Dial dia. (mm)	Grip dia. (mm)	Total length (without bit) (mm)	Dimensions (mm)			Weight (kg)	Included Accessory Bits	
									Driver shaft (mm)		L1		D1	phillips
1DPSK	0.2~1	0.025	N1DPSK	2~10 cN-m	0.25 cN-m	78	22	217	152	6		0.075		
2DPSK	0.5~2	0.05	N2DPSK	5~20 "	0.5 "			195	130					
5DPSK	1~5	0.2	N5DPSK	10~50 "	2 "			208	143					
10DPSK	2~10	0.2	N10DPSK	20~100 "	2 "			222	130					
20DPSK	5~20	0.5	N20DPSK	0.5~2 N-m	0.05 N-m			242	130					
50DPSK	10~50	2	N50DPSK	1~5 "	0.2 "	36	300	188	14	0.47	No.1 No.2	Standard bits SB type		
10DPSK(II)	2~10	0.2	N10DPSK(II)	20~100 cN-m	2 cN-m	78	33	222	130	12			0.33	
20DPSK(II)	5~20	0.5	N20DPSK(II)	0.5~2 N-m	0.05 N-m	78	33	242	130	12			0.36	
50DPSK(II)	10~50	2	N50DPSK(II)	1~5 "	0.2 "	78	36	300	188	14	0.47			
10DPSK(II)	2~10	0.2	N10DPSK(II)	20~100 cN-m	2 cN-m	78	33	222	130	12	0.29			
20DPSK(II)	5~20	0.5	N20DPSK(II)	0.5~2 N-m	0.05 N-m	78	33	242	130	12	0.32			
50DPSK(II)	10~50	2	N50DPSK(II)	1~5 "	0.2 "	78	36	300	188	14	0.42			

SGK TORQUE GAUGES

Capable of accurately measuring very low torque values.

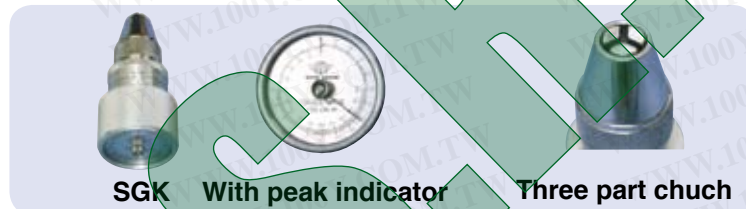

SGK With peak indicator Three part chuck

* Peak indicator is optional

USING AN SGK GAUGE

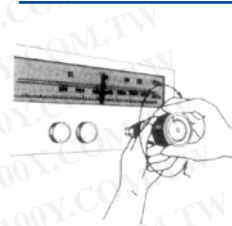

Starting torque can be measured with the chuck gripping a knob or shaft of an electronic device.
Rotate clockwise or counterclockwise.

(Rotate CW or CCW)



FEATURES

- Due to their miniature design and light weight, these gauges are convenient and easy to carry.
- A three part chuck with knurled surface enables firmly gripping even odd shapes.
- The inset scale face helps avoid incidental damage.
- The gauges measure clockwise and counterclockwise.
- With scales on the sides and the face, torque readings can be obtained either way.
- Accuracy $\pm 3\%$ of the indicated value over the full range

Model SGK	Range (CW/CCW)	Increment	Model N-SGK	Range (CW/CCW)	Increment	Chucking dia. (mm)	Total length (mm)	Dimensions (mm)				Weight (kg)
								Grip dia.		Total length (without chuck)		
	gf-cm/kgf-cm	gf-cm		mN-m/cN-m		mm	mm	D1	D2	L1	L2	kg
90(I)SGK	10~90gf-cm	2 gf-cm	N90(I)SGK	1~9 mN-m	0.2 mN-m	1-6.5	106	43	36	83	57.5	0.29
150(I)SGK	20~150 "	2 "	N150(I)SGK	2~15 "	0.2 "							
300(I)SGK	40~300 "	5 "	N300(I)SGK	4~30 "	0.5 "							
600(I)SGK	50~600 "	10 "	N600(I)SGK	5~60 "	1 "							
1200(I)SGK	100~1200 "	20 "	N1200(I)SGK	10~120 "	2 "							
2400(I)SGK	200~2400 "	50 "	N2400(I)SGK	20~240 "	5 "	1-8.5	132	63	53	102	72	0.6
1.5(II)SGK	0.1~1.5kgf-cm	0.02kgf-cm	N1.5(II)SGK	1~5 cN-m	0.2 cN-m							
2.4(II)SGK	0.2~2.4 "	0.02 "	N2.4(II)SGK	2~24 "	0.2 "							
3.6(II)SGK	0.4~3.6 "	0.05 "	N3.6(II)SGK	4~36 "	0.5 "							
6(II)SGK	0.5~6 "	0.1 "	N6(II)SGK	5~60 "	1 "							
9(II)SGK	1~9 "	0.2 "	N9(II)SGK	10~90 "	2 "							
15(II)SGK	1~15 "	0.2 "	N15(II)SGK	10~150 "	2 "							

BITS

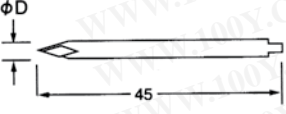
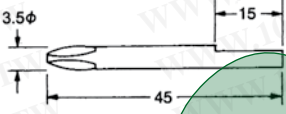
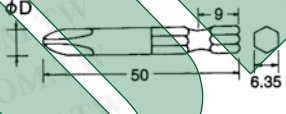
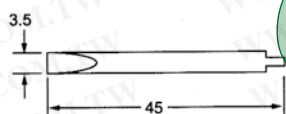
ดอกไขควงสำหรับประแจปอนด์ด้ามไขควง BITS FOR TORQUE DRIVERS

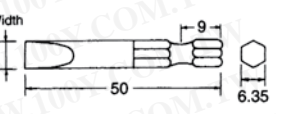
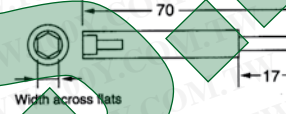
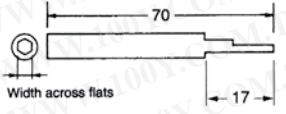
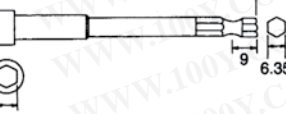
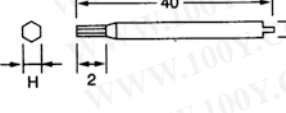
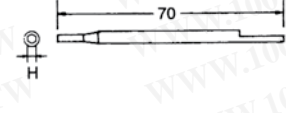
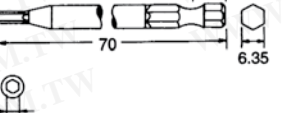
Type	KANON bits CB type	KANON bits OB type	Standard bits SB type																																								
Applicable drive	N1.5,3 LTDK (N)1.5,3 STDK OI 22,44, STDK	1.5,3 LTDK (N)1,2,5 DPSK	(N)1.5,3 LTDK-H (N) 6, 12, 20 LTDK (N) 30, 50, 100 LTDK OI 200 LTDK PI 30, 50, LTDK (N) 6, 12, 20, 30, 50, 100 STDK OI 80, 200 STDK PI 20, 30, 50, 100 STDK (N) 10, 20, 50, DPSK (N) 10, 20, 50, DPSKII																																								
Phillips	 <p>Unit : mm</p> <table border="1"> <thead> <tr> <th>φD</th> <th>Bit sizes</th> </tr> </thead> <tbody> <tr> <td rowspan="3">3.5φ</td> <td>No.0</td> </tr> <tr> <td>No.1</td> </tr> <tr> <td>No.2</td> </tr> </tbody> </table>	φD	Bit sizes	3.5φ	No.0	No.1	No.2	 <p>Unit : mm</p> <table border="1"> <thead> <tr> <th>φD</th> <th>Bit sizes</th> </tr> </thead> <tbody> <tr> <td rowspan="3">3.5φ</td> <td>No.0</td> </tr> <tr> <td>No.1</td> </tr> <tr> <td>No.2</td> </tr> </tbody> </table>	φD	Bit sizes	3.5φ	No.0	No.1	No.2	 <p>Unit : mm</p> <table border="1"> <thead> <tr> <th>φD</th> <th>Bit sizes</th> </tr> </thead> <tbody> <tr> <td>4φ</td> <td>No.0</td> </tr> <tr> <td rowspan="3">7φ</td> <td>No.1</td> </tr> <tr> <td>No.2</td> </tr> <tr> <td>No.3</td> </tr> </tbody> </table>	φD	Bit sizes	4φ	No.0	7φ	No.1	No.2	No.3																				
φD	Bit sizes																																										
3.5φ	No.0																																										
	No.1																																										
	No.2																																										
φD	Bit sizes																																										
3.5φ	No.0																																										
	No.1																																										
	No.2																																										
φD	Bit sizes																																										
4φ	No.0																																										
7φ	No.1																																										
	No.2																																										
	No.3																																										
Slot Drive	 <p>Unit : mm</p> <table border="1"> <thead> <tr> <th>Blade thickness</th> <th>Width</th> </tr> </thead> <tbody> <tr> <td>0.4 mm</td> <td>3.5 mm</td> </tr> </tbody> </table>	Blade thickness	Width	0.4 mm	3.5 mm	 <p>Unit : mm</p> <table border="1"> <thead> <tr> <th>Blade thickness</th> <th>Width</th> </tr> </thead> <tbody> <tr> <td>0.4 mm</td> <td>3.5 mm</td> </tr> </tbody> </table>	Blade thickness	Width	0.4 mm	3.5 mm	 <p>Unit : mm</p> <table border="1"> <thead> <tr> <th>Blade thickness</th> <th>Width</th> </tr> </thead> <tbody> <tr> <td>0.4 mm</td> <td>4.0 mm</td> </tr> <tr> <td>1.0 mm</td> <td>7.0 mm</td> </tr> </tbody> </table>	Blade thickness	Width	0.4 mm	4.0 mm	1.0 mm	7.0 mm																										
Blade thickness	Width																																										
0.4 mm	3.5 mm																																										
Blade thickness	Width																																										
0.4 mm	3.5 mm																																										
Blade thickness	Width																																										
0.4 mm	4.0 mm																																										
1.0 mm	7.0 mm																																										
BOX BITS	 <p>Unit : mm</p> <table border="1"> <thead> <tr> <th colspan="5">Width across flats</th> </tr> </thead> <tbody> <tr> <td>3</td> <td>4</td> <td>5</td> <td>5.5</td> <td>6</td> </tr> </tbody> </table>	Width across flats					3	4	5	5.5	6	 <p>Unit : mm</p> <table border="1"> <thead> <tr> <th colspan="5">Width across flats</th> </tr> </thead> <tbody> <tr> <td>3</td> <td>4</td> <td>5</td> <td>5.5</td> <td>6</td> </tr> </tbody> </table>	Width across flats					3	4	5	5.5	6	 <p>Unit : mm</p> <table border="1"> <thead> <tr> <th colspan="5">Width across flats</th> </tr> </thead> <tbody> <tr> <td>4</td> <td>5</td> <td>5.5</td> <td>6</td> <td>7</td> </tr> <tr> <td>8</td> <td>9</td> <td>10</td> <td>11</td> <td>12</td> </tr> <tr> <td>13</td> <td>14</td> <td>17</td> <td></td> <td></td> </tr> </tbody> </table>	Width across flats					4	5	5.5	6	7	8	9	10	11	12	13	14	17		
Width across flats																																											
3	4	5	5.5	6																																							
Width across flats																																											
3	4	5	5.5	6																																							
Width across flats																																											
4	5	5.5	6	7																																							
8	9	10	11	12																																							
13	14	17																																									
HEX BITS	 <p>Unit : mm</p> <table border="1"> <thead> <tr> <th colspan="5">Edge size (H) mm</th> </tr> </thead> <tbody> <tr> <td>1.27</td> <td>1.5</td> <td>2</td> <td>2.5</td> <td>3</td> </tr> </tbody> </table>	Edge size (H) mm					1.27	1.5	2	2.5	3	 <p>Unit : mm</p> <table border="1"> <thead> <tr> <th colspan="5">Edge size (H) mm</th> </tr> </thead> <tbody> <tr> <td>1.27</td> <td>1.5</td> <td>2</td> <td>2.5</td> <td>3</td> </tr> </tbody> </table>	Edge size (H) mm					1.27	1.5	2	2.5	3	 <p>Unit : mm</p> <table border="1"> <thead> <tr> <th colspan="5">Edge size (H) mm</th> </tr> </thead> <tbody> <tr> <td>1.27</td> <td>1.5</td> <td>2</td> <td>2.5</td> <td>3</td> </tr> <tr> <td>4</td> <td>5</td> <td>6</td> <td>8</td> <td></td> </tr> </tbody> </table>	Edge size (H) mm					1.27	1.5	2	2.5	3	4	5	6	8						
Edge size (H) mm																																											
1.27	1.5	2	2.5	3																																							
Edge size (H) mm																																											
1.27	1.5	2	2.5	3																																							
Edge size (H) mm																																											
1.27	1.5	2	2.5	3																																							
4	5	6	8																																								

勝特力材料 886-3-5753170
 勝特力电子(上海) 86-21-34970699
 勝特力电子(深圳) 86-755-83298787
 Http://www.100y.com.tw

What is torque ?

The torque is a unit to tighten a screw.

It means rotating force, and should be clearly distinguished from tensible force.

The torque wrench (torque driver) belongs to the field of rotating torque. It may be said that the simple lever is applied to the torque. For the both members are closely related to <force> and <distance>.

A distance is a length of a bar, force is referred to a sum of force weighing on the bar's end.

For example, the bar length is 20cm, where 5kgf (a force unit indicated kgf) is added, - a formula is established as follows.

However, provided that there are presented factors such as.

$T = \text{torque (kgf-cm, kgf-cm)}$

$F = \text{added force (kgf), F means forc.}$

$L = \text{bar length (cm, m),}$

the torque can be obtained as follows;

$F(\text{force}) \times L(\text{length}) = T(\text{torque}),$
 accordingly, $5\text{kgf} \times 20\text{cm} = 100\text{kgf-cm}$

In order to obtain 100kgf.cm torque, length and force are estimated as follows.

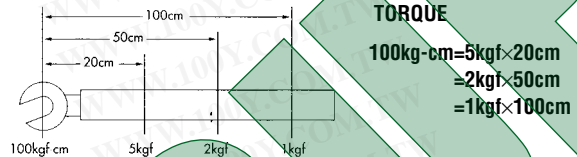

PARTS FOR QLK, QSPK AND QCK

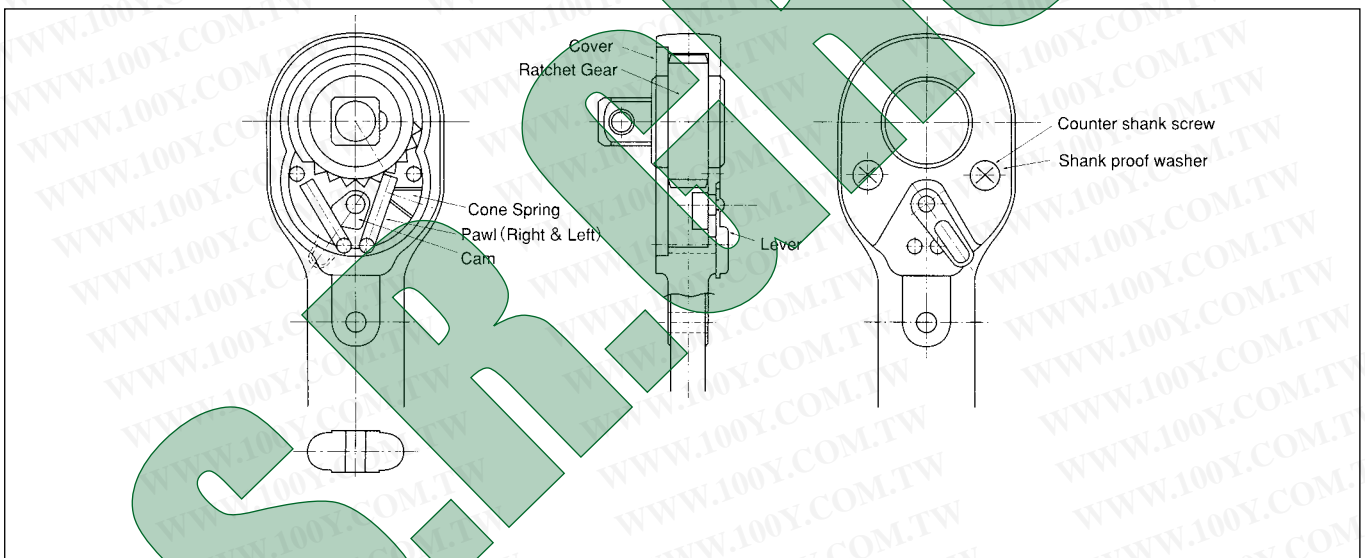

Torque unit and conversion table

	Drive unit (kilo-gram-cm)	SI unit (Newton meter)	Inch and pound unit
Torque unit	kgf-cm kgf-m gf-m	N-m cN-m	lbf-in lbf-ft OZf-in
Conversion in unit	1 kgf-cm=100 gf-cm 1 kgf-cm=1000 gf-cm 1 kgf-cm 10 kgf-mm	1 N-m=100 cN-m	1 lbf-Ft=12 lbf-in 1 lbt-in=16 OZf-in
Conversion between units	1 kgf-cm=0.098065 N-m 1 kgf-cm=0.867962 lbf-in 1 kgf-cm=0.072330 lbf-Ft	1 N-m=10.1972 kgf-cm 1 N-m=8.85 lbf-in 1 N-m=0.737562 lbf-Ft	1 lbf-in=1.15 kgf-cm 1 lbf-in=0.112985 N-m 1 lbf-Ft=13.825 kgf-cm 1 lbf-Ft=1.36 N-m
Force unit	1 kgf-cm=9.807 N 1 kgf-cm=2.205 lbf	1 N=0.101972 kgf 1 N=0.224809 lbf	1 lbf=0.453592 kgf 1 lbf=4.448 N (1 lbf=16 OZf)
Length unit	1 cm=0.393701 in	1 m=3.281 ft	1 in=2.54 cm 1 Ft=0.305 m (1 Ft=12 in)