

CS1-VA 數位式 電壓/電流表

產品敘述

CS1-VA 為一經濟型電壓/電流顯示表，在設計上具有高精度的測量，顯示和通信範圍為 0~600V 或 0~10A 的 DC/AC/TRMS。
可選購 1 組繼電器輸出、1 組類比輸出或 1 組 RS485(Modbus RTU 模式) 多功能的控制,警報,傳輸與通訊在廣泛的工業測試與應用



勝特力材料 886-3-5753170
 勝特力电子(上海) 86-21-34970699
 勝特力电子(深圳) 86-755-83298787
[Http://www.100y.com.tw](http://www.100y.com.tw)

特點

- 可量測 DC / AC / TRMS ; 電壓 0~600V 或電流 0~10A。
- 可附加三選一選購 1 組繼電器輸出、1 組類比輸出 或 1 組 RS485(Modbus RTU mode)通訊 功能。
- 1 組繼電器輸出可設定 Hi / Lo / Hi Hold / Lo Hold 並具有 起動延遲 / 復歸間隙 / 動作延遲及復歸延遲 功能。
- 可選購類比輸出或 RS 485 通訊埠。
- 通過 CE 及 RoHS 認證。

應用

- 測試設備與電壓/電流測量，與 PC/PLC 做通訊控制或警報。
- MCC 盤、機械裝置或開關裝置的電壓/電流測量與 PC/PLC 做遠端的輸入輸出或警報。

規格選擇表

CS1-VA - DC/AC/TRMS 輸入範圍 - 選購功能 - 工作電源

CODE	電壓輸入	CODE	電流輸入	CODE	選購功能	CODE	工作電源
D	直流	D	直流	N	無功能	A	AC 115/230 V
A	交流	A	交流	R1	1 組繼電器	OPTION 2	
T	真有效值	T	真有效值	V	0(1) - 5 V / 0 - 10 V	ADH*	AC/DC 85-264V
V1	0 - 199.99 mV	A1	0 - 199.99 μA	I	0 - 10mA 0(4)-20 mA	ADL*	DC 20-56V
V2	0 - 1.9999 V	A2	0 - 1.9999 mA	8	RS 485		
V3	0 - 19.999 V	A3	0 - 19.999 mA	繼電器, 類比輸出或 RS485 埠 只能三選一			
V4	0 - 199.99 V	A4	0 - 199.99 mA				
V5	0 - 300.0 V	A5	0 - 1.9999 A				
V6	0 - 600.0 V	A6	0 - 1.0000 A				
VA	0-50 mV	A7	0 - 5.000 A				
VB	0-60 mV	A8	0 - 10.000 A				
VC	0-100 mV	AO	指定電流範圍				
VO	指定電壓範圍						

技術規格

輸入規格

輸入範圍 DC / AC / TRMS		輸入阻抗	量測範圍 DC / AC / TRMS		輸入阻抗
電壓	0-50/-100 mV	≥5M ohm	電流	0-199.99μA	1K ohm
	0-199.99 mV	≥5M ohm		0-1.9999 mA	100 ohm
	0-1.9999 V	≥1M ohm		0-19.999 mA	10 ohm
	0-19.999 V	≥1M ohm		0-199.99 mA	1 ohm
	0-199.99 V	≥1M ohm		0-1.9999 A	0.05 ohm
	0-300.0 V	≥2M ohm		0-5.000 A	0.02 ohm
0-600.0 V	≥2M ohm	0-10.000 A	0.01 ohm		

校正方式:

根據校正程序由按鍵操作

A/D 轉換:

16 bits resolution

精確度:

直流: ≤± 0.04% of FS ± 1C

交流: ≤± 0.1% of FS ± 1C

取樣速度:

15 次/秒

反應速度:

≤ 100 毫秒(當 $R_{uG} = '1'$)

顯示與功能

LED:

數值: 5 位數, 0.8"(20.0mm) 字高, 紅色高亮度 LED

繼電器輸出指示: 1 方型紅色 LED

RS 485 通訊: 1 方型橘色 LED

E.C.I. 功能指示: 1 方型綠色 LED

最大/最小保持指示: 2 方型橘色 LED

下鍵 功能指示 (最大 (最小)值保持復歸/

PV 保持/相對 PV): 1 方型綠色 LED

顯示範圍:

-19999~29999;

顯示範圍設定:

LoSC: 顯示低值設定: -19999~+29999

HiSC: 顯示低值設定: -19999~+29999

可設定 0 / 0.0 / 0.00 / 0.000 / 0.0000

小數點設定:

超高溢位顯示:

超低溢位顯示:

最大值/最小值紀錄:

顯示功能:

面板鍵功能:

ouFL: 當輸入訊號超過輸入上限的 120%

-ouFL: 當輸入訊號低過輸入上限的 -120%

記錄開機期間所發生的最大值及最小值

可設定顯示 PV / 最大 (最小)值保持/ RS 485

可設定: 相對 PV / PV 保持/最大 (最小)值保持復歸/

繼電器復歸

可設定範圍:-19999~29999

PuPro: 可設定範圍: -19999~+29999

PuSPn: 可設定範圍: -19999~+29999

顯示值穩定功能

平均值顯示:

可設定範圍 1~99 次

移動平均值顯示:

可設定範圍 1~99 次

數位濾波:

可設定範圍 1~99 次

控制功能(選購)

設定點:

1 組設定點

繼電器:

1 組繼電器, FORM-C, 5A/230Vac, 10A/115V

繼電器動作模式:

Hi / Lo / Hi.HLd / Lo.HLd 功能

繼電器動作功能:

每個繼電器皆可設定個別的起動延遲及復歸延遲

及動作間隙

啟動不動作帶: 0~9999counts

啟動時間延遲: 0:00.0~9(分鐘):59.9(秒)

動作時間延遲: 0:00.0~9(分鐘):59.9(秒)

復歸時間延遲: 0:00.0~9(分鐘):59.9(秒)

動作間隙: 0~5000 counts

類比輸出(選購)

精確度:	±0.1% of F.S.
漣波率:	≤0.1% of F.S.
反應速度:	≤100 m-sec. (10~90%額定輸出)
隔離度:	耐壓交流 2000V 在輸出及輸入之間
輸出範圍:	電壓輸出 或 電流輸出(請於規格選擇表中選定) 電壓輸出: 0-5V / 0-10V / 1-5V 可規劃 電流輸出: 0-10mA / 0-20mA / 4-20mA 可規劃
輸出推動能力:	電壓輸出: 0-10V; ≥ 1000Ω; 電流輸出: 4(0)-20mA: ≤ 500Ω max
功能:	[RaHS] 輸出訊號上限所對應的顯示高值設定 可設定範圍: -19999~29999 [RaLS] 輸出訊號下限所對應的顯示低值設定 可設定範圍: -19999~29999
輸出訊號調整:	RaPn: 可設定範圍: -38011~+27524 RaSpn: 可設定範圍: -38011~+27524

RS 485 通信(選購)

通訊協議:	Modbus RTU 模式
串列傳輸速率:	1200/2400/4800/9600/19200/38400 可設定
波特率:	8 位元
同位元檢查:	奇、偶 or 無 (有 1 or 2 停止位元) 可設定
通訊地址:	1-255 可設定
遠端顯示:	主要從 RS485 通訊中顯示讀值
接線距離:	1200M
終端電阻:	150Ω

電氣特性

介電強度:	耐壓交流 2.0 KV 持續 1 分鐘, 電源 / 輸入 / 輸出 / 外殼 之間
絕緣電阻:	在 500Vdc 小於 100M ohm, 電源 / 輸入 / 輸出之間
隔離:	電源 / 輸入 / 繼電器, 類比訊號, RS485 之間
EMC:	EN 55011:2002; EN 61326:2003
安全規範(LVD):	EN 61010-1:2001
工作環境	
工作溫度:	0~60 °C
工作濕度:	20~95 %RH, 無結露
溫度係數:	≤100 PPM/°C
儲存溫度:	-10~70 °C
防護等級:	前面板: IEC 529 (IP52); 外殼: IP20

機構尺寸

外觀尺寸:	96mm(寬) x 48mm(高) x 72mm(深)
開孔尺寸:	92mm(寬) x 44mm(高)
外殼材質:	ABS 防火材料 (UL 94V-0)
安裝方式:	盤面安裝
接線端子:	Plastic NYLON 66 (UL 94V-0) #A1-A3(電流輸入): 20A/300Vac, M3.5, 12-22AWG 其他: 10A 300Vac, M2.6, 16-22AWG
重量:	350 克

電源

工作電源:	AC115/230V, 50/60Hz; 選購: AC 85~264V, DC 100~300V 或 DC 20~56V
耗電量:	小於 3.0VA
記憶儲存:	EEPROM

前面板說明



尺寸外觀

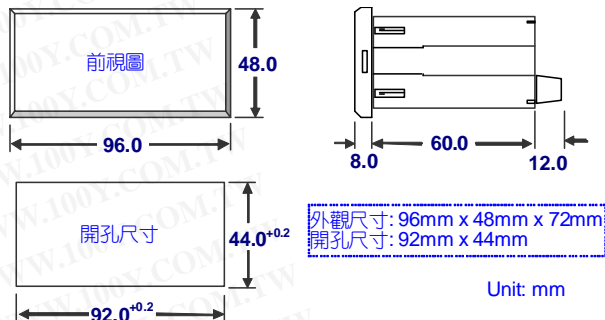

安裝方式

本表請安裝在不超過最大操作溫度和溼度的環境下

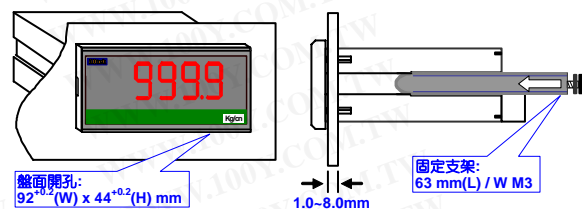

接線圖

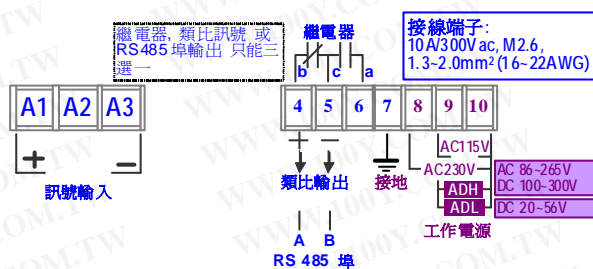

接線時, 請務必確認電源電壓是否正確並接入正確端子編號。為設備及儀表安全, 建議在儀表前安裝保險絲(Fuse) 或 斷路器(Breaker)。

⚠ 接線有可能變更, 請依照儀表上的接線圖接線。

工作電源

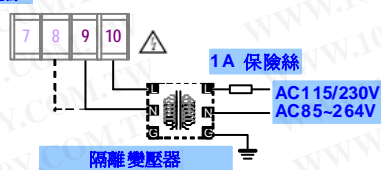

輸入接線

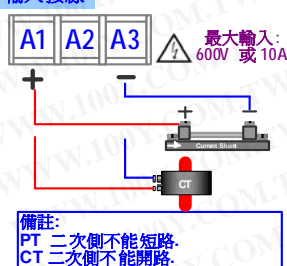

RS485 通訊埠

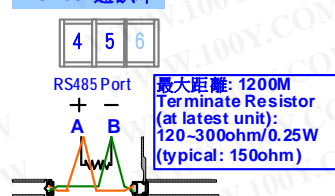

Amend: 2010/4/26: Modify the terminals and range for DC power supply from AC/DC 20~56V to DC 20~56V.

■ 功能說明

顯示範圍設定功能:

在 [InPUt GroUP] 中的 [LoSC] (顯示低值) 與 [HiSC] (顯示高值) 設定以對應輸入信號。可設定反向對應輸入訊號(輸入訊號下限對應顯示高值及 輸入訊號上限對應顯示低值)。請參閱下圖

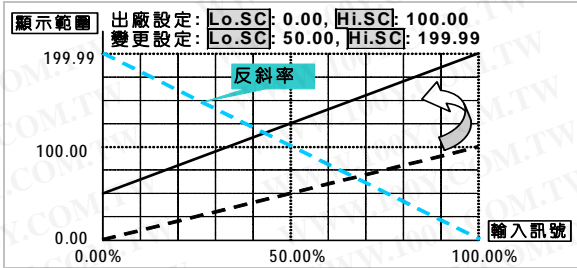

*Too narrow scale may cause display lower resolution.

顯示功能

最大(小)值儲存:

本表可以存儲通電期間所讀入的最大最小值; 並可進入 [user level] 一般操作階層中直接查閱

顯示功能:

(操作步驟第 A-07)

可於 [輸入功能群組] 中設定選擇 [dSPly] 對應是 PV / Max(Mini) Hold / RS 485

顯示值 [Pu] : 此顯示當前輸入信號的值最大(小)值保持 [P.Hd] / 最小(小)值保持 [M.Hd]

本表會持續紀錄通電後所發生的最大(最小)值, 直到手動清除紀錄。手動清除有三種方式: [User Level], [External Control Input] 當 [E.C.I.] 功能關閉則按 Up/Down Key(上升/下降鍵), 即執行清除最大(小)值並開始紀錄新的最大(小)值。隨表附有功能標示貼紙; 請將 [MRS] 貼於指示燈方 [MRS] 以標示功能狀態

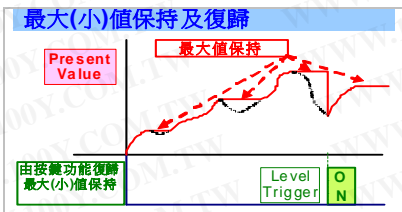

RS485 命令做遠端顯示 [5485]:

本表的一個創新功能就是通過 RS485 接收主機傳送過來的數值, 並顯示於下視窗中。以前, 儀表主要接收 PLC 的 AO 模組 4~20mA 或 0~10V 信號 或 BCD 模組作遠端顯示。我們提供了通過 RS485 將數值寫入儀表視窗做顯示, 不但節省了材料施工成本, 益便於維護。

前面板按鍵功能:

可在 [InPUt GroUP] 中 [dnPEY] 設定, 相對 PV / PV 保持 / 最大(小) 保持復歸 / 繼電器復歸

相對 PV [ELPu]: [dnPEY] 功能可在中設定

[ELPu] 功能 當按下 [] 鍵, 將顯示差異值(ΔPV), 直到再按一次 [] 鍵。

▶ 請將 [R.PV] 貼在方型綠色 LED 的右邊, 以示功能。

PV Hold [P.Hd]: [dnPEY] 功能可設定顯示值保持,

[P.Hd] 功能: 當按下 [] 鍵, 顯示將被保持直到再按一次 [] 鍵。

▶ 請將 [P.V.H] 貼在方型綠色 LED 的右邊, 以示功能。

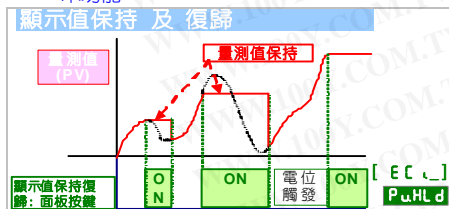

最大(小) 保持復歸: 當 [dSPly] 在 [InPUt GroUP] 設定 [P.Hd] 或 [M.Hd], [dnPEY] 功能可以設定 [R.St] 復歸。(當顯示最大或最小值保持時。)

繼電器復歸: 當 [rY lnd] 在 [rELAY GroUP] 可設定 [H.Hld] 或 [LoHld], [dnPEY] 功能可以設定 [R.St] 復歸。(當繼電器, 激磁或不導通時。)

低值遮蔽:

如果設置的值是正數, 這意味著當絕對值 PV ≤ 設定值, 顯示為 0。如果設置的值是負數, 這意味著當在設定值 PV (PV ≤ -設定值), 將顯示設定值

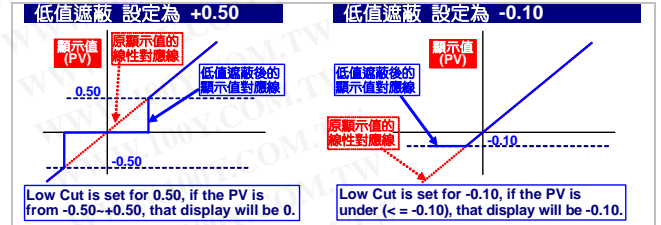

數位微調:

以往, 工程師在現場試車時, 顯示值常會產生一些不確定的誤差, 現場又不易取得標準訊號產生器時, 需花費時間來回調整顯示高值及低值以符合現場顯示要求。

[PuPro] & [PuSPn] 功能中, 直接設定對應當時輸入訊號的數值(Just Key in the Value), 以達調整顯示值符合現場要求的目的。可由 [PSClr] 功能來清除數位微調的調整值。

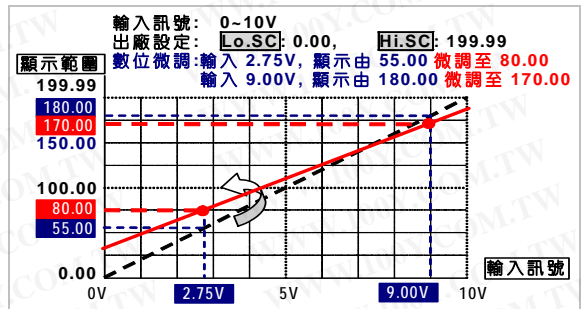

讀值穩定功能

平均值顯示:

本儀表的標準取樣速度為 15 次/秒; 此功能(AVG)若設定為 3 時, 則代表取樣 3 次後計算平均值再更新顯示值; 此時顯示值更新速度將為 5 次/秒。

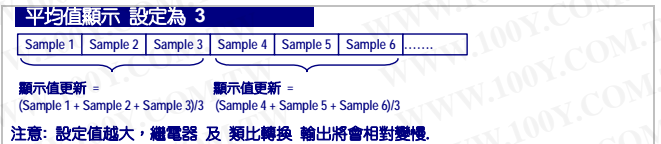

移動平均值顯示:

此功能(M.AVG)若設定為 3 時, 則代表開機第一週期將取樣 3 次計算平均值更新顯示值之後此時顯示值更新速度除第一週期外, 其後都將為 15 次/秒。



數位濾波:

數位濾波可降低現廠電磁干擾。

控制功能 (選購)

繼電器動作模式:

Hi/Lo/Hi.Hld/Lo.Hld 動作功能

Hi: 當 PV > Set-Point, 繼電器輸出

Lo: 當 PV < Set-Point, 繼電器輸出

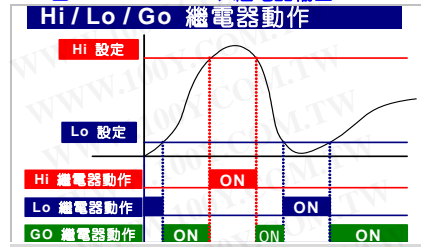

Hi.Hld (Lo.Hld): 當顯示值高於(或低於)設定點時, 繼電器將輸出並保持, 直到手動強制復歸。在 **[User Level]** 中之復歸功能選擇 **YES** (當 **[dJrEY]** 功能設定 **[YrSE]**)。

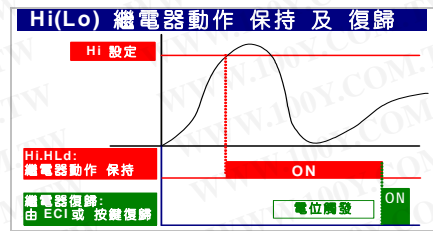

動作功能:

啟動延遲 / 繼電器動作與復歸延遲 / 動作間隙

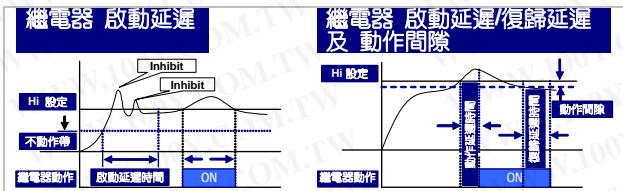

類比輸出 (選購)

訂購時請指定輸出類別 0~10V 或 4(0)~20mA; 此類比輸出可根據顯示值設定對應顯示低值與高值; 亦可設定反向對應顯示值(輸出訊號下限對應顯示高值及輸出訊號上限對應顯示低值)。

輸出範圍:

電壓: 可設定 0-5V / 0-10V / 1-5V

電流: 可設定 0-10mA / 0-20mA / 4-20mA

功能:

Ro.HS: 在輸出訊號上限時設定對應顯示高值(如同 4~20mA 輸出 20mA 時設定對應顯示 150.0)

Ro.LS: 在輸出訊號下限時設定對應顯示低值(如同 4~20mA 輸出 4mA 時設定對應顯示 50.0)

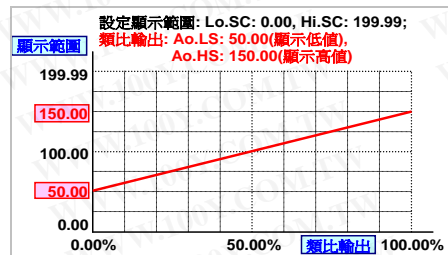

The range between **Ro.HS** and **Ro.LS** should be over 20% of span at least; otherwise, it will be got less resolution of analogue output.

輸出低值與高值微調:

使用者可以經由顯示表前方按鍵, 校調類比輸出。請將顯示表類比輸出的端子連接標準電表以量測輸出值。按顯示表前方按鍵(上移或下移鍵), 可調整輸出和確認顯示表的讀值直到進入精度範圍(±0.1%)。

Ro.Pro: 類比輸出低值微調;

調整範圍: -38011~27524;

Ro.SPn: 類比輸出高值微調;

調整範圍: -38011~27524;

RS 485 通訊 (選購)

Modbus RTU mode 通訊協定。通訊速率可達 38400 bps; 使用者可利用 RS485 設定參數、讀取顯示值、遠端顯示。執行遠端監視接點輸入及控制輸出等功能。

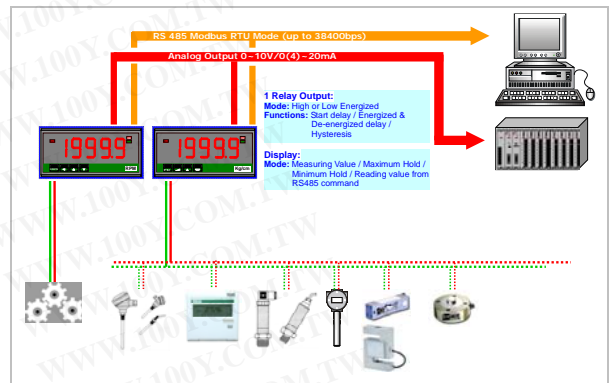

遠端顯示:

顯示表可透過 RS485 接受主機(Master)傳過來的數值當顯示值。過去, 顯示表通常接受 PLC 的 BCD 模組或 AO 模組的 4~20mA 或 0~10V 顯示對應值。我們提供了新的方法, 主機透過 RS485 指令將數值寫入顯示表示窗做顯示; 不但節省了施工成本、亦易於維護。

當 **[dJPLY]** 設定為 **[S485]**, 則顯示值將由 RS485 傳過來的指令與資料。這個資料(數值)將與顯示值作用相同, 與設定點比較做繼電器動作、使類比訊號對應輸出...等。



■ 錯誤訊息說明

確認規格及接線無誤後，接通電源開關進行自我檢測。

開機自檢後錯誤說明：

顯示畫面	詳細說明	其他說明
ouFL	顯示值正溢位元(信號超出可顯示範圍)	(請檢查輸出信號是否正常)
-ouFL	顯示值負溢位元(信號低於可顯示範圍)	(請檢查輸出信號是否正常)
ouFL	ADC 正溢位元(信號高於輸入上限的 20%)	(請檢查輸出信號是否正常)
-ouFL	ADC 負溢位元(信號低於輸入下限的 20%)	(請檢查輸出信號是否正常)
EEP → FAIL	EEPROM 故障	(請送回原廠檢修)
A.C.nG ← Pu	未執行輸入信號校正	(請執行輸入校正信號)
A.C → FAIL	輸入信號校正異常	(請檢查校正時的輸入信號是否正常)
RoC.nG ← Pu	未執行輸出信號校正	(請執行輸出校正程式)
RoC → FAIL	輸出信號校正異常	(類比輸出校正錯誤)

■ 操作鍵

*當開始使用儀錶之前，請先進入儀錶程式層檢查程序是否有誤。

■ 工作鍵: 4 鍵如下 輸入(功能) / 位移(跳出) / 上移鍵 / 下移鍵

■ 電錶工作鍵設計如電腦鍵盤 和 。在任何階層 按下 代表 "輸入"或 "確認設定"，按下 代表"回上一層" () 或 "跳出"。

■ 在任何階層沒有動作 輸入超過 2 分鐘，或按下 1 分鐘.就會回到錶頭通常畫面

	功能索引	設定狀態
(=) Enter/Fun key	(1) 在任何頁面,按 鍵進入階層 或功能索引 (2) 進入功能索引做設定。	(3)設置完成會儲存到 EEPROM，再進入到下一個階級。
(=) Shift key	(1)在量測頁面，按 鍵超過一秒可進入使用者階層。 (2)在目錄下，按 鍵超過一秒可回上一層。 (3)在目錄下，按 鍵超過一秒以上 可回到量測範圍面。	(4)在設定狀態下，按 鍵 位移設定點。 (5)在設定狀態下，按 鍵超過 1 秒可到功能索引畫面。
(=) Up key	(1)在功能索引，按 鍵回到上一層索引層。	(2)在設定狀態下，按 鍵選擇功能。 (3)在數值設定中,按 鍵 選擇增加數值
(=) Down key	(1)在功能索引，按 鍵進入到下一層索引層。	(2)在設定狀態下，按 鍵選擇功能 (3)在數值設定中,按 鍵 選擇減少數值。

■ 操作面板



■ 顯示:

0.8" (20.0mm) 紅色高亮 LED 4 2/3 位元顯示。

■ I/O 狀態指示

● 繼電器動作: 1 紅色方型 LED

當繼電器動作，RL1 顯示

● RS485 通訊: 1 橘色方型 LED

當電錶傳輸數據，COM 會閃爍，且 COM 閃爍越快表示資料傳輸數目更快

● 最大值/最小值 保持指示: 2 橘色方型 LED

顯示: 當最大值/最小值 保持功能選擇時，就會有顯示。

■ 功能貼紙:

● 設定為不同功能時，可使用此貼紙標示

● 繼電器功能符號: **HH** **Hi** **Lo** **LL** **DO**

● 下鍵功能模式:

PV.H PV.H(PV Hold) / **Tare** Tare / **DI** DI(數位輸入)

M.RS M.RS(最大或最小 復歸) /

R.RS R.RS(由繼電器動作復歸)

● Engineer Label: over 80 types.

■ 操作鍵: 4 鍵型式 Enter(Function) / Shift(Escape) / Up key / Down key

■ 密碼功能: 設定範圍:0000~9999;

只要您輸入正確密碼就可以進入參數設定階層 [level]。本表可以在參數設定階層改變密碼，如果您忘記密碼請與我們公司聯繫。

● 鎖定功能: 4 層鎖定模式

● None **[nonE]**: 不鎖定。

● User Level **[USEr]**: 一般操作階層鎖定。

● Programming Level **[EnG]**: 參數設定階層鎖定。

● ALL **[ALL]**: 所有都鎖定。

■ 面板鍵功能:

● 下鍵 可選擇 **[ELPu]** / **[PuHld]** / **[rSt]** / **[YrSt]**

■ 操作流程

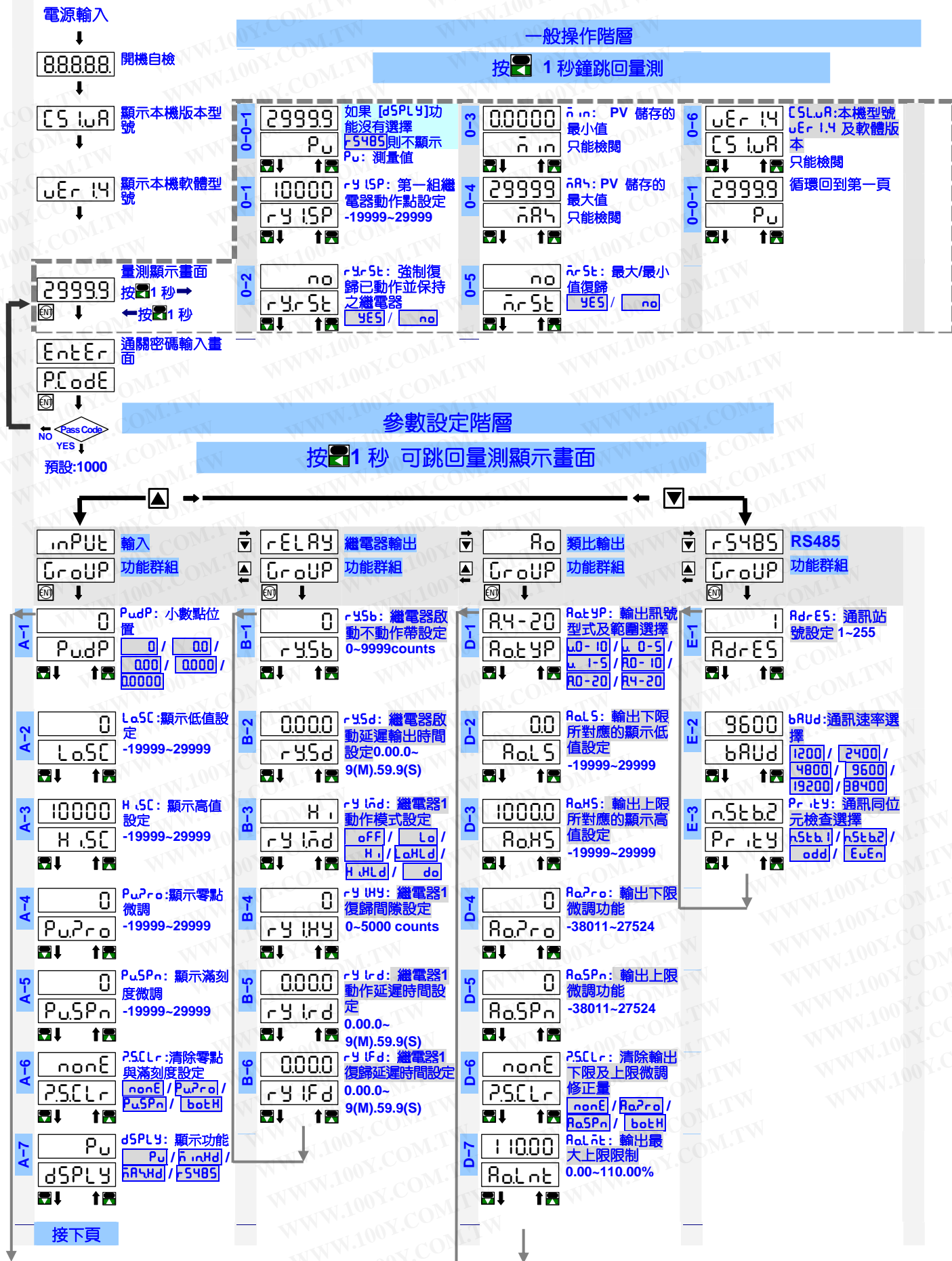

A-8	0 LoCut	LoCut: 低值遮蔽 功能 -19999~29999
A-9	5 Ave	Ave: 顯示平均次 數 1(None)~ 99 times
A-10	1 mave	mave: 顯示移動 平均次數 1(None)~ 10 times
A-11	0 dFilt	dFilt: 數位濾波 次數 0(None)1~ 99 times
A-12	nonE dntEY	dntEY: 下鍵功 能指定 nonE / FELPu / PwHld / rSE / rSE
A-13	0 PCodE	PCodE: 參數設定 階層的密碼設定 0000~9999
A-14	nonE FLocY	FLocY: 參數鎖定 設定 nonE / USEr / EnG / ALL

勝特力材料 886-3-5753170
 勝特力电子(上海) 86-21-34970699
 勝特力电子(深圳) 86-755-83298787
[Http://www.100y.com.tw](http://www.100y.com.tw)

CS1-VA VOLT / CURRENT Meter

DESCRIPTION

CS1-VA economic type Voltage/Current Indicator has been designed with high accuracy measurement, display and communication of 0~600V or 0~10A for DC/AC/TRMS.

They are also available 1 option of 1 Relay outputs, 1 Analogue output or 1 RS485 (Modbus RTU Mode) interface with versatile functions such as control, alarm, re-transmission or communication for a wide range of industrial and testing applications.



勝特力材料 886-3-5753170
 勝特力电子(上海) 86-21-34970699
 勝特力电子(深圳) 86-755-83298787
 Http://www.100y.com.tw

FEATURE

- Measuring Voltage 0~600V or Current 0~10A for DC / AC / TRMS
- Option available 1 of 1 relay, 1 analogue output or RS485(Modbus RTU mode)
- 1 relay can be programmed individual to be a Hi / Lo / Hi Latch / Lo Latch energized with Start Delay / Hysteresis / Energized & De-energized Delay functions.
- Analogue output or RS 485 communication port in option
- CE Approved & RoHS

APPLICATIONS

- Testing Equipments for Volt/Current Measuring, Alarm, Control and Communication with PC/PLC
- MCC panel, Machinery, Switch gear... for Voltage or Current Measuring, Alarm and Remote I/O with PC/PLC

ORDERING INFORMATION

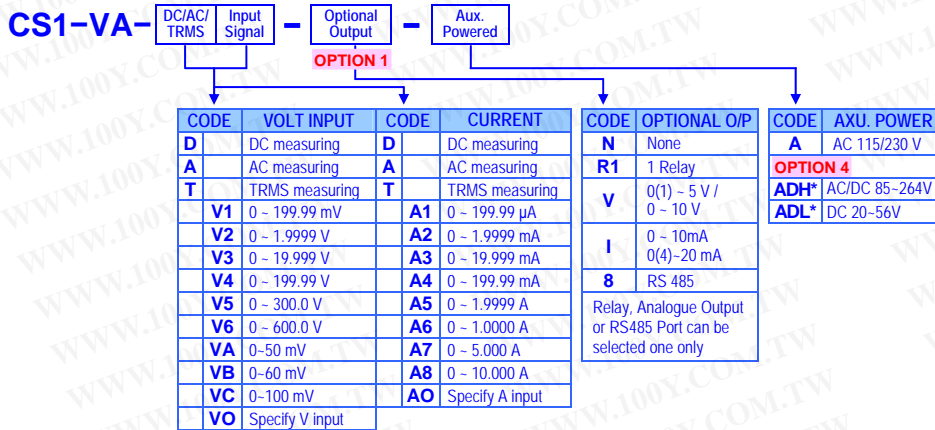

TECHNICAL SPECIFICATION

Input		Measuring Range		Input Impedance	
Measuring Range	DC / AC / TRMS	DC / AC / TRMS	DC / AC / TRMS	DC / AC / TRMS	Input Impedance
Voltage	0-50/-100 mV	≥5M ohm	Current	0-199.99μA	1K ohm
	0-199.99 mV	≥5M ohm		0-1.9999 mA	100 ohm
	0-1.9999 V	≥1M ohm		0-19.999 mA	10 ohm
	0-19.999 V	≥1M ohm		0-199.99 mA	1 ohm
	0-199.99 V	≥1M ohm		0-1.9999 A	0.05 ohm
	0-300.0 V	≥2M ohm		0-5.000 A	0.02 ohm
	0-600.0 V	≥2M ohm		0-10.000 A	0.01 ohm

- Calibration:** Digital calibration by front key
- A/D converter:** 16 bits resolution
- Accuracy:** DC: $\leq \pm 0.04\%$ of FS $\pm 1C$
AC: $\leq \pm 0.1\%$ of FS $\pm 1C$
- Sampling rate:** 15 cycles/sec
- Response time:** ≤ 100 m-sec.(when the $R_{UL} = "1"$) in standard

Display & Functions

- LED:** Numeric: 5 digits, 0.8"(20.0mm)H red high-brightness LED
Relay output indication: 1 square red LED
RS 485 communication: 1 square orange LED
E.C.I. function indication: 1 square green LED
Max/Mini Hold indication: 2 square orange LED
Down key function indication (Reset for Max. (Mini.) Hold / PV Hold / Relative. PV): 1 square green LED
- Display range:** -19999~29999;

Scaling function:

L_{5C} : Low Scale; Settable range: -19999~+29999
H_{5C} : High Scale; Settable range: -19999~+29999

Decimal point:

Programmable from 0 / 0.0 / 0.00 / 0.000 / 0.0000

Over range indication:

oofL, when input is over 20% of input range Hi

Under range indication:

-oofL, when input is under -20% of input range Lo

Max / Mini recording:

Maximum and Minimum value storage during power on.

Display functions:

PV / Max(Mini) Hold / RS 485 Programmable

Front key functions:

Relative PV / PV Hold / Reset for maxi(mini) hold /

Low cut:

Reset for relay energized latch programmable

Digital fine adjust:

Settable range: -19999~29999 counts

Reading Stable Function

Average:

Settable range: 1~99 times

Moving average:

Settable range: 1(None)~10 times

Digital filter:

Settable range: 0(None)/1~99 times

Control Functions(option)

Set-points:

One set-point

Control relay:

1 Relay, FORM-C, 5A/230Vac, 10A/115V

Relay energized mode:

Energized levels compare with set-points:

Energizing functions:

Hi / Lo / Hi.HLd / Lo.HLd programmable

Start delay / Energized & De-energized delay / Hysteresis

Energized Latch

Start band(Minimum level for Energizing): 0~9999counts

Start delay time: 0:00.0~9(Minutes):59.9(Second)

Energized delay time: 0:00.0~9(Minutes):59.9(Second)

De-energized delay time: 0:00.0~9(Minutes):59.9(Second)

Hysteresis: 0~5000 counts

Analogue output(option)

Accuracy:	±0.1% of F.S.
Ripple:	≤100 m-sec. (10-90% of input)
Response time:	≤100 m-sec. (10-90% of input)
Isolation:	AC 2.0 KV between input and output
Output range:	Specify either Voltage or Current output in ordering Voltage: 0-5V / 0-10V / 1-5V programmable Current: 0-10mA / 0-20mA / 4-20mA programmable
Output capability:	Voltage: 0-10V: ≥ 1000Ω Current: 4(0)-20mA: ≤ 500Ω max
Functions:	RaHS (output range high): Settable range: -19999-29999 RaLS (output range Low): Settable range: -19999-29999
Digital fine adjust:	RaPr : Settable range: -38011~+27524 RaSPn : Settable range: -38011~+27524

■ DIMENSIONS

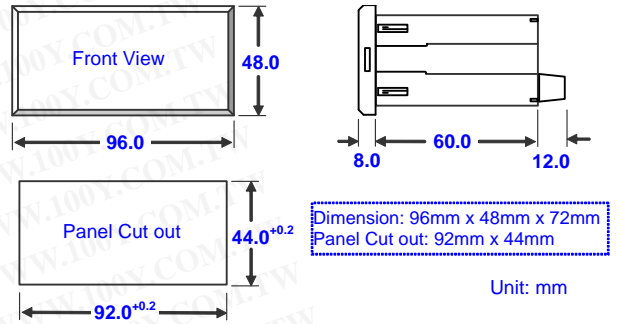

RS 485 Communication(option)

Protocol:	Modbus RTU mode
Baud rate:	1200/2400/4800/9600/19200/38400 programmable
Data bits:	8 bits
Parity:	Even, odd or none (with 1 or 2 stop bit) programmable
Address:	1 - 255 programmable
Remote display:	to show the value from RS485 command of master
Distance:	1200M
Terminate resistor:	150Ω at last unit.

Electrical Safety

Dielectric strength:	AC 2.0 KV for 1 min, Between Power / Input / Output / Case
Insulation resistance:	≥100M ohm at 500Vdc, Between Power / Input / Output
Isolation:	Between Power / Input / Relay, Analogue, RS485
EMC:	EN 55011:2002; EN 61326:2003
Safety(LVD):	EN 61010-1:2001

Environmental

Operating temp.:	0-60 °C
Operating humidity:	20-95 %RH, Non-condensing
Temp. coefficient:	≤100 PPM/°C
Storage temp.:	-10-70 °C
Enclosure:	Front panel: IEC 529 (IP52); Housing: IP20

Mechanical

Dimensions:	96mm(W) x 48mm(H) x 72mm(D)
Panel cutout:	92mm(W) x 44mm(H)
Case material:	ABS fire-resistance (UL 94V-0)
Mounting:	Panel flush mounting
Terminal block:	Plastic NYLON 66 (UL 94V-0) #A1-A3(current input): 20A/300Vac, M3.5, 12-22AWG Others: 10A 300Vac, M2.6, 16-22AWG
Weight:	350g

Power

Power supply:	AC115/230V,50/60Hz; Optional: AC 85-264V, DC 100-300V or DC 20-56V
----------------------	--

Power consumption:	3.0VA maximum
Back up memory:	By EEPROM

■ FRONT PANEL

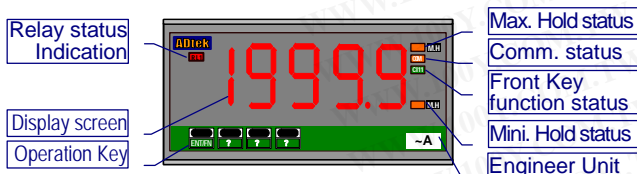

■ INSTALLATION

The meter should be installed in a location that does not exceed the maximum operating temperature and provides good air circulation.

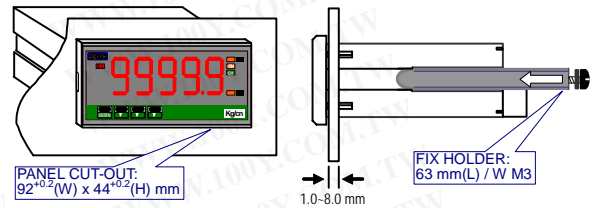

■ CONNECTION DIAGRAM

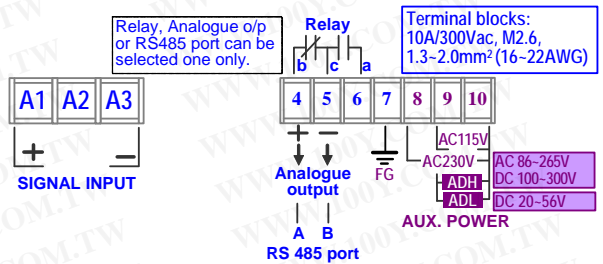

Please check the voltage of power supplied first, and then connect to the specified terminals. It is recommended that power supplied to the meter be protected by a fuse or circuit breaker.

Power Supply

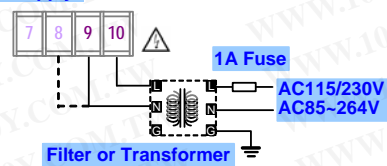

Input connection

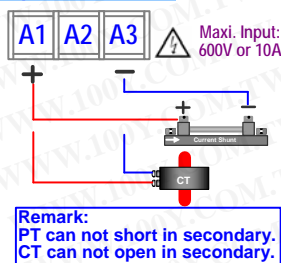

RS485 Communication Port

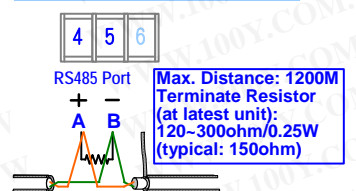

Amend: 2010/4/26: Modify the terminals and range for DC power supply from AC/DC 20-56V to DC 20-56V.

FUNCTION DESCRIPTION

Scaling function:

Setting the [LASC] (Low scale) and [HASC] (High scale) in [INPUT GROUP] to relative input signal. Reverse scaling will be done too. Please refer to the figure as below,

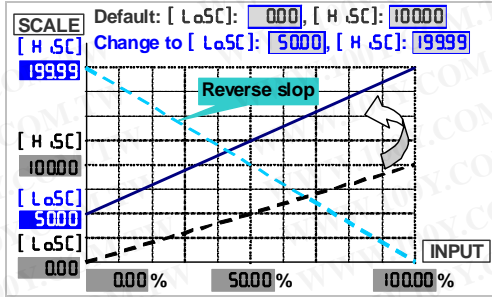

*Too narrow scale may cause display lower resolution.

Display & Functions

Max / Mini recording:

The meter will storage the maximum and minimum value in [user level] during power on in order to review drifting of PV.

Display functions:

(Please refer to step A-07)

PV / Max(Mini) Hold / RS 485 programmable in [dSPLY] function of [INPUT GROUP]

Present Value [PV]: The display will show the value that Relative to Input signal.

Maximum Hold [MH] / Minimum Hold [MH]:

The meter will keep display in maximum (minimum) value during power on, until press front key to reset (If the down key function in [INPUT GROUP] has been set to [RST].)

▶ Please find the [MH] sticker that enclosure the package of the meter to stick on the right side of square orange LED

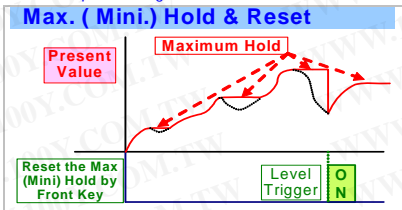

Remote Display by RS485 command [F5485]:

The meter will show the value that received from RS485 sending. In past, The meter normally receive 4~20mA or 0~10V from AO or digital output from BCD module of PLC. We support a new solution that PV shows the value from RS485 command of master can so that can be save cost and wiring from PLC.

Front key functions:

Relative PV / PV Hold / Reset for maxi(mini) hold / Reset for relay energized latch programmable in [dSPLY] function of [INPUT GROUP]

Relative PV [ELPV]: [dSPLY] function can be set to be [ELPV] function. When user press the [KEY] key, the display will show the differential value(ΔPV), until press [KEY] key again.

▶ Please find the [RPV] sticker to stick on the right side of square green LED.

PV Hold [PVHLD]: [dSPLY] function can be set to be [PVHLD] function. When user press the [KEY] key, the display will be hold until press the [KEY] key again.

▶ Please find the [PVH] sticker to stick on the right side of square green LED.

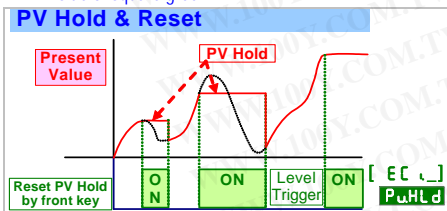

Reset for Max(Mini) Hold: when the [dSPLY] in [INPUT GROUP] set to be [MH] or [MH], [dSPLY] function can be set to be [RST] to reset the display when it is holding in maxi or mini value.
Reset for relay energized latch: when the [RY Latch] in [RELAY GROUP] set to be [HLD] or [LHLD], [dSPLY] function can be set to be [RST] to reset the relay when it is energizing and latching.

Low cut:

If the setting value is positive, it means when the absolutely value of PV ≤ Setting value, the display will be 0. If the setting value is negative, it means when the PV under setting value (PV ≤ -Setting value), the display will be setting value.

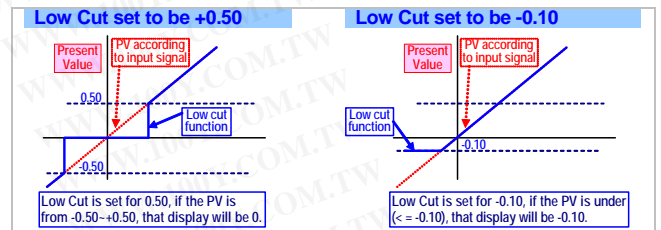

Digital fine adjustment:

Users can get Fine Adjustment for Zero & Span of PV by front key of the meter, and "Just Key In" the value which user want to show in the current input signals.

Especially, the [PWR0] & [PUSP0] are not only in zero & span of PV, but also any lower point for [PWR0] & higher point for [PUSP0]. The meter will be linearization for full scale.

The adjustment can be clear in function [P5CLR]

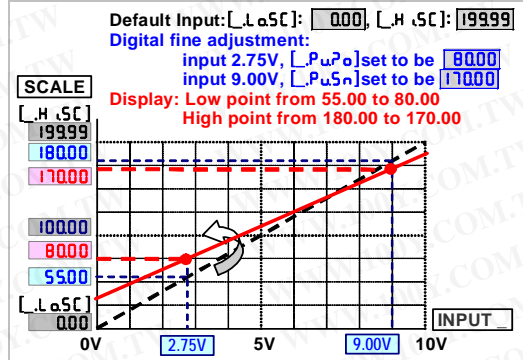

Reading Stable Function

Average:

Basically, the sampling rate of meter is 15cycles/sec. If the function set to be 3 times, It means the meter will update of display will be 5 times/sec.

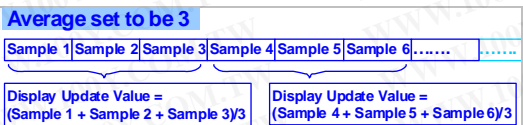

Remark: The higher average setting will cause the response time of Relay and Analogue output slower.

Moving average:

If the function to be set 3 times, the meter will update delay in first 3 samples, then it will update 15 times/sec continuously.

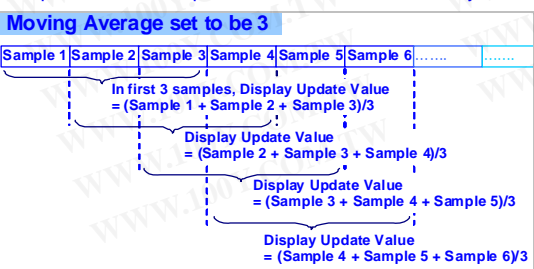

Remark: The higher moving average setting wouldn't cause the response time of Relay and Analogue output slower after first 3 samples.

Digital filter:

The digital filter can reduce the magnetic noise in field.

Control functions(option)

Relay energized mode:

Hi / Lo / Hi.Hld / Lo.Hld programmable
H : Relay will energize when PV > Set-Point
L : Relay will energize when PV < Set-Point

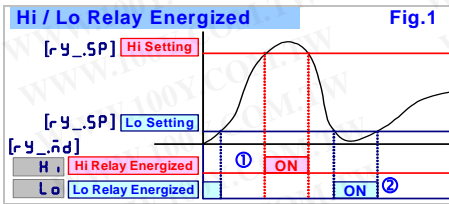

Hi.Hld (Lo.Hld): When the PV is Higher (or lower) than set-point, the relay will be energized and latch until manual reset by from key in [user level] or press down key to reset (If the [dLrSt] function set to be [YrSt])

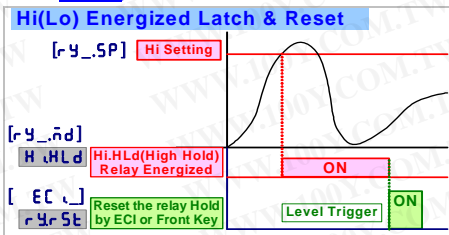

Energized functions:

Start delay / Energized & De-energized delay / Hysteresis

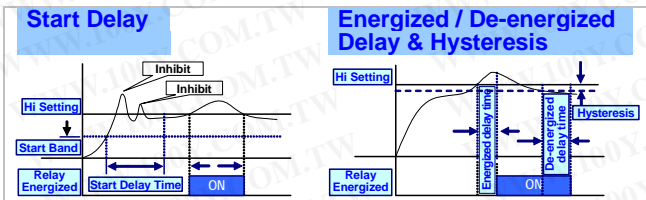

Analogue output(option)

Please specify the output type either an 0~10V / 0~10V / 1~5V programmable
 Current: 0~10mA / 0~20mA / 4~20mA programmable
 on various display values. Reverse slope output is possible by reversing point positions.

Output range:

Voltage: 0~5V / 0~10V / 1~5V programmable
 Current: 0~10mA / 0~20mA / 4~20mA programmable

Functions:

RoHS (output range high): setting the Display value High to versus output range High(as like as 20mA in 4~20)
RoLS (output range Low): setting the Display value Low to versus output range Low(as like as 4mA in 4~20)

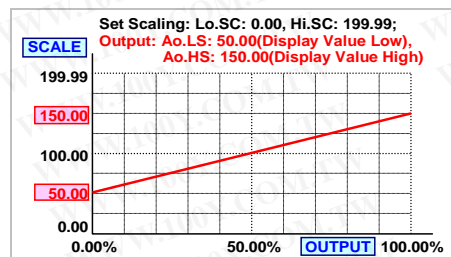

The range between **RoHS** and **RoLS** should be over 20% of span at least; otherwise, it will be got less resolution of analogue output.

Fine zero & span adjustment:

Users can get Fine Adjustment of analogue output by front key of the meter. Please connect standard meter to the terminal of analogue output. To press the front key (up or down key) of meter to adjust and check the output.

[Pa?r0]: Fine Zero Adjustment for Analog Output;
 Settable range: -38011~27524;

[PaSPn]: Fine Span Adjustment for Analog Output;
 Settable range: -38011~27524;

RS 485 Communication(option)

The RS485's protocol is Modbus RTU mode, and baud rate up to 38400 bps. It's convenience to remote monitoring, display for reading.

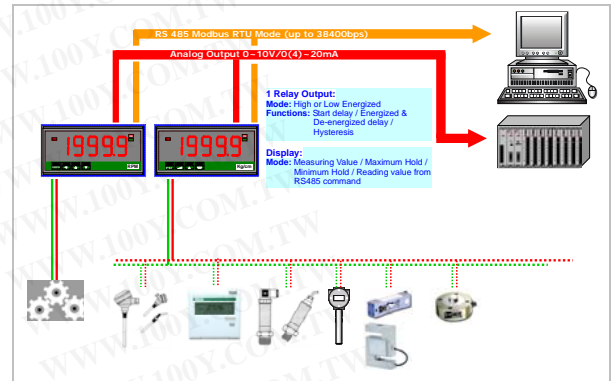

Remote display:

The meter will show the value that received from RS485 command. In past, The meter normally receive 4~20mA or 0~10V from AO or digital output from BCD module of PLC. We support a new solution that PV shows the value from RS485 command of master so that can be **save cost and wiring** from PLC. When the [d5PLy] set to be RS485, it means, the PV screen will show the number from RS485 command & data. The data (number) will be same as PV that will compare with set-point, analogue output and ECI functions so that is to control analogue output, relay energized and so on.

CS1 APPLICATION FOR REMOTE DISPLAY FROM RS485 COMMAND



■ ERROR MESSAGE

BEFORE POWER ON, PLEASE CHECK THE SPECIFICATION AND CONNECTION AGAIN.

SELF-DIAGNOSIS AND ERROR CODE:

DISPLAY	DESCRIPTION	REMARK
ouFL	Display is positive-overflow (Signal is over display range)	(Please check the input signal)
-ouFL	Display is negative-overflow (Signal is under display range)	(Please check the input signal)
ouFL	ADC is positive-overflow (Signal is higher than input 120%)	(Please check the input signal)
-ouFL	ADC is negative-overflow (Signal is lower than input -120%)	(Please check the input signal)
EEP → FAIL	EEPROM occurs error	(Please send back to manufactory for repaired)
A.i.nG → Pu	Calibrating Input Signal do not process	(Please process Calibrating Input Signal)
A.i.C → FAIL	Calibrating Input Signal error	(Please check Calibrating Input Signal)
A.o.nG → Pu	Calibrating Output Signal do not process	(Please process Calibrating Output Signal)
A.o.C → FAIL	Calibrating Output Signal error	(Please check Calibrating Output Signal)

■ OPERATING KEY

*Please access to the Programming Level to check and set the parameters when users start to run the meter

■ **Operating Key:** 4 keys for Enter(Function) / Shift(Escape) / Up key / Down key

■ The meter has designed operation similar as PC's and . In any page, press key means "enter" or "confirm setting", and press key means "escape()" or "shift".

■ In Programming Level, the screen will return to Measuring Page after do not press any key over 2 minutes, or press for 1 second.

	Function Index	Setting Status
(=) Enter/Fun key	(1) In any page, press to access the level or function index (2) From the function index to access setting status	(3) Setting Confirmed, save to EEProm and go to next function index
(=) Shift key	(1) In measuring page, press for 1 second to access user level. (2) In function index, press for 1 second to go back upper level. (3) In function group index, press for 1 second to go back measuring page	(4) In setting status, press to Shift the setting position. (5) In setting status, press for 1 second to abort setting and go back this function index.
(=) Up key	(1) In function index, press to go back to previous function index	(2) In setting status for function, press to select function (3) During number Setting, press can roll the digit up
(=) Down key	(1) In Function Index Page, press will go to the next Function Index Page.	(2) In setting status for function, press to select function (3) During number Setting, press can roll the digit down.

■ FRONT PANEL



■ Numeric Screens

0.8" (20.0mm) red high-brightness LED for 4 2/3 digital present values.

■ I/O Status Indication

● **Relay Energized:** 1 square red LED

RL1 display when Relay 1 energized;

● **RS485 Communication:** 1 square orange LED

COM will flash when the meter is receive or send data, and **COM** flash quickly means the data transient quicker.

● **Max/Mini Hold indication:** 2 square orange LEDs

MH displayed: When the display function has been selected in Maximum or Minimum Hold function.

■ Stickers:

Each meter has a sticker what are functions and engineer label enclosure.

● **Relay energized mode:** **HH Hi Lo LL DO**

● Down key functions mode:

PV.H PV.H(PV Hold) / **Tare** Tare / **DI** DI(Digital Input)

M.RS M.RS(Maximum or Minimum Reset) /

R.RS R.RS(Reset for Relay Latch)

● **Engineer Label:** over 80 types.

■ **Operating Key:** 4 keys for Enter(Function) / Shift(Escape) / Up key / Down key

■ **Pass Word:** Settable range:0000~9999;

User has to key in the right pass word so that get into **[Programming level]**. Otherwise, the meter will go back to measuring page. If user forgets the password, please contact with the service window.

■ **Function Lock:** There are 4 levels programmable.

● **None** **nonE**: no lock all.

● **User Level** **USEr**: User Level lock. User can get into User Level for checking but setting.

● **Programming Level** **EnG**: Programming level lock. User can get into programming level for checking but setting.

● **ALL** **ALL**: All lock. User can get into all level for checking but setting.

■ **Front Key Function:**

● The Key can be set to be **ELPu** / **PuHLd** / **nRS** / **rRS** programmable.

OPERATING DIAGRAM (The detail description of operation, please refer to operating manual.)

CS1-VA

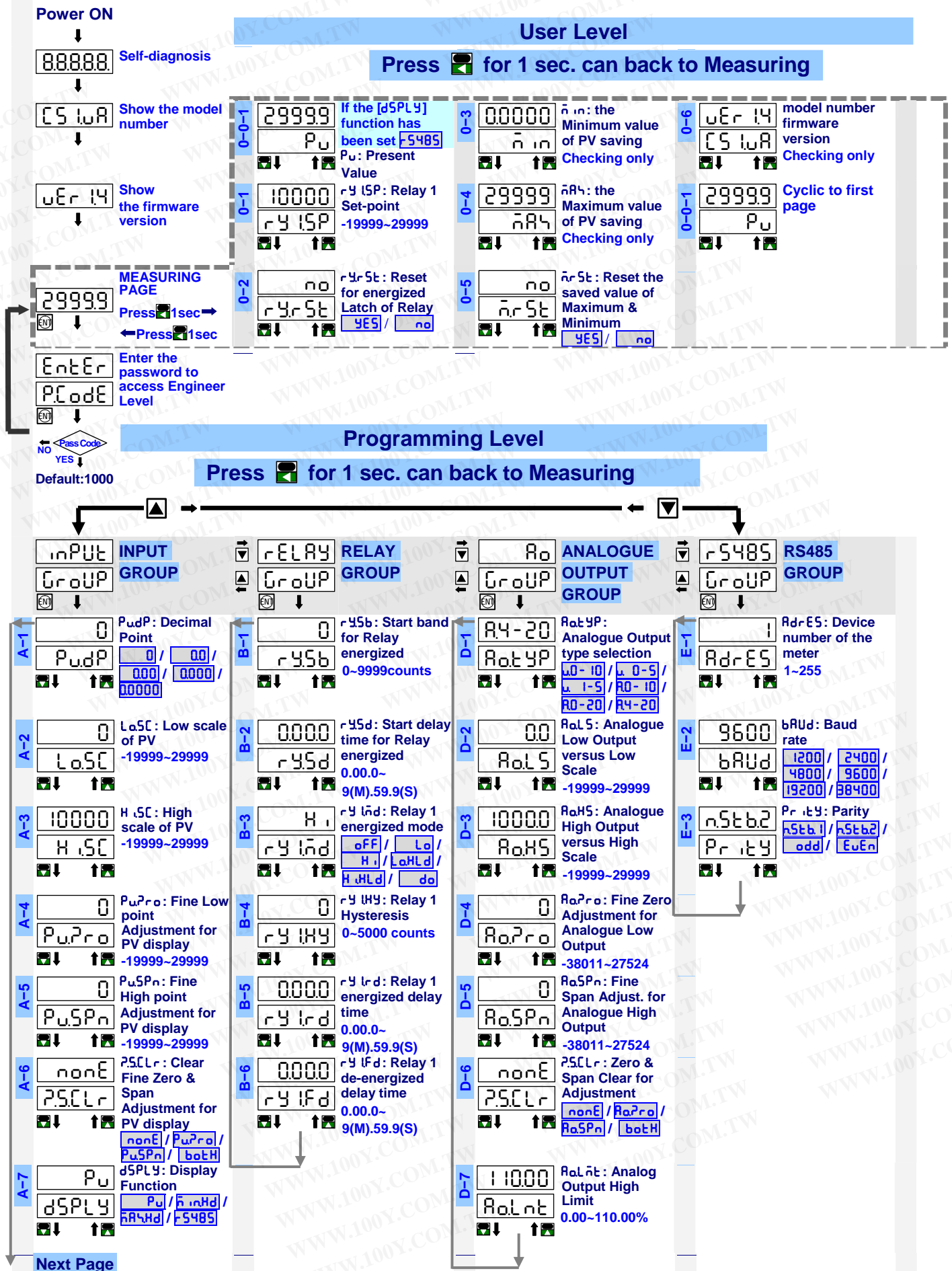

A-8	LoCUT	LoCUT : Low Cut Function Function -19999~29999
A-9	AVG	AVG : Average update for PV 1(None)~99 times
A-10	MAVG	MAVG : Moving Average update for PV 1(None)~10 times
A-11	DFILT	DFILT : Digital filter 0(None)/1~99 times
A-12	DNKEY	DNKEY : Down key function nonE / FELPu / PwHld / rSE / r5t
A-13	PCODE	PCODE : Pass Code for enter Engineer Level 0000~9999
A-14	FLock	FLock : Function Level Lock nonE / USEr / EnG / ALL

- ▶ Please refer to operating manual for detail description
- ▶ Please refer to operating manual for Banks function description and operating.

勝特力材料 886-3-5753170
 勝特力电子(上海) 86-21-34970699
 勝特力电子(深圳) 86-755-83298787
[Http://www.100y.com.tw](http://www.100y.com.tw)