

Solid-state Timer H3DS

勝特力電材超市-龍山店 886-3-5773766
 勝特力電材超市-光復店 886-3-5729570
 勝特力電子(上海) 86-21-34970699
 勝特力電子(深圳) 86-755-83298787
<http://www.100y.com.tw>

DIN Track Mounted, Standard 17.5-mm Width Timer Range

- A wide AC/DC power supply range (24 to 230 VAC/ 24 to 48 VDC) reduces the number of timer models kept in stock. (24 to 230 VAC/VDC with H3DS-XL□)
- Smart Dial/Selector-locking Mechanism: Prevents the dials and selectors on the Timer's front panel from being inadvertently operated or being operated without authorization. The lock can only be unlocked and locked with an optional pen-type Lock Key.
- Screw-Less Clamp type available. (H3DS-□LC)
- Sticker provided for easy timer identification and management.
- Terminal clamp left open when delivered (screw terminal type).
- Finger protection terminal block to meet VDE0106/P100.
- Enables easy sequence checks through instantaneous outputs for a zero set value at any time range.
- Incorporates environment-friendly, cadmium-free contacts.
- Conforms to EN61812-1 and IEC60664-1 4 kV/2 for Low Voltage, and EMC Directives.

■ Broad Line-up of H3DS Series

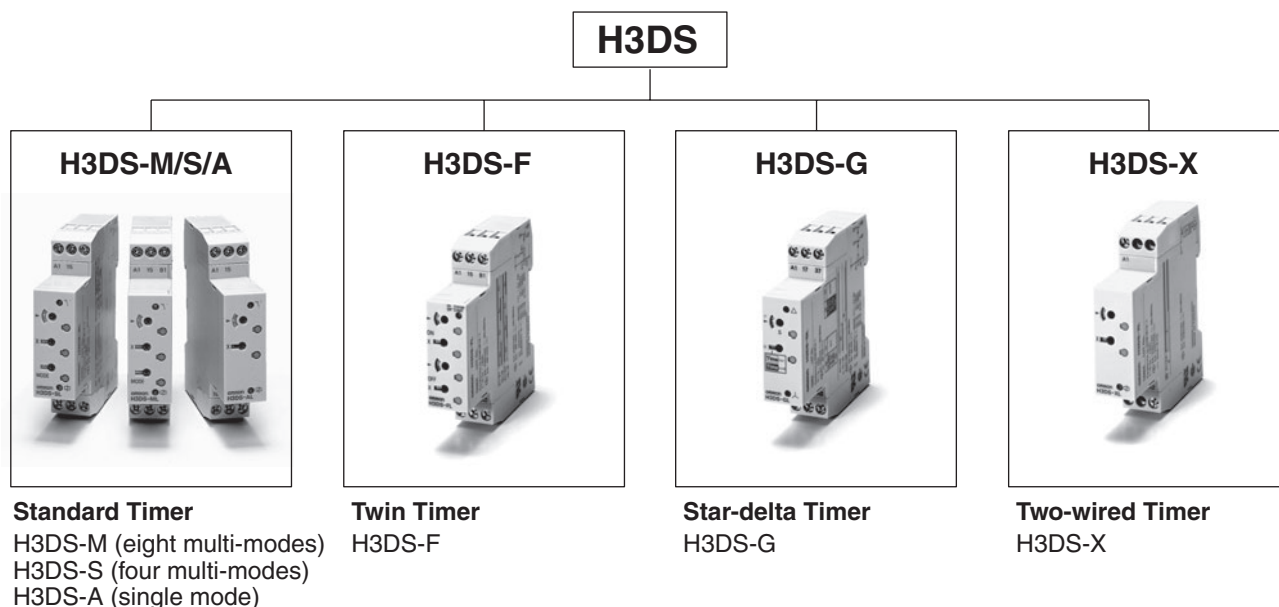

Contents

Solid-state Timer

H3DS-M/-S/-A.....	2
H3DS-F.....	13
H3DS-G.....	20
H3DS-X.....	27

Common to ALL Timers

Installation of Screw-Less Clamp Models.....	33
Accessories.....	36
Precautions.....	37

Solid-state Multi-functional Timer H3DS-M/-S/-A

- Eight operating modes (H3DS-M) and four operating modes (H3DS-S) cover a wide range of applications.
- A wide time setting range of 0.10 s to 120 h.
- Two LEDs indicate power and relay status respectively.



Model Number Structure

Model Number Legend

H3DS - \square \square L \square
1 2 3

1. M: Multi-function type
S: Standard type
A: Single-function type
2. L: Smart lock mechanism
3. None: Screw terminal type
C: Screw-Less Clamp type

Ordering Information

List of Models

Supply voltage	Control output	Input type	Operating mode (see note)	Model	
				Screw terminal type	Screw-Less Clamp type
24 to 230 VAC (50/60Hz)/ 24 to 48 VDC	Contact output: SPDT (time-limit output SP- DT)	Voltage input	Eight multi-modes: A, B, B2, C, D, E, G, J	H3DS-ML	H3DS-MLC
		No-input available	Four multi-modes: A, B2, E, J	H3DS-SL	H3DS-SLC
			Single mode: A	H3DS-AL	H3DS-ALC

Note: The operating modes are as follows:

- A: ON-delay
- B: Flicker OFF start
- B2: Flicker ON start
- C: Signal ON/OFF-delay
- D: Signal OFF-delay
- E: Interval
- G: Signal ON/OFF-delay
- J: One shot

■ Accessories (Order Separately)

Lock Key		Y92S-38
Mounting Track	50 cm (l) x 7.3 mm (t)	PFP-50N
	1 m (l) x 7.3 mm (t)	PFP-100N
	1 m (l) x 16 mm (t)	PFP-100N2
End Plate		PFP-M
Spacer		PEP-S

Specifications

■ General

Item	H3DS-ML□	H3DS-SL□	H3DS-AL□
Operating mode	A: ON-delay (Signal or Power) B: Flicker OFF start (Signal or Power) B2: Flicker ON start (Signal or Power) C: Signal ON/OFF-delay D: Signal OFF-delay E: Interval (Signal or Power) G: Signal ON/OFF-delay J: One-shot (Signal or Power)	A: ON-delay B2: Flicker ON start E: Interval J: One-shot	A: ON-delay (fixed)
Input type	Voltage input	---	
Output type	Relay: SPDT		
External connections	Screw terminal, Screw-Less Clamp		
Terminal block	Screw terminal type: Clamps two 2.5-mm ² max. bar terminals without sleeves. Screw-Less Clamp type: Clamps two 1.5-mm ² max. bar terminals without sleeves.		
Terminal screw tightening torque	0.98 N·m max.		
Mounting method	DIN track mounting (see note)		
Attachment	Nameplate label		
Approved standards	UL508, CSA C22.2 No.14 Conforms to EN61812-1, IEC60664-1 4 kV/2, VDE0106/P100 Output category according to IEC60947-5-1 (AC-13; 250 V 5 A/AC-14; 250 V 1 A/AC-15; 250 V 1 A/DC-13; 30 V 0.1 A/DC-14; 30 V 0.05 A)		

Note: Can be mounted to 35-mm DIN Track with a plate thickness of 1 to 2.5 mm.

■ Time Ranges

Time scale display	Time range
0.1 s	0.1 to 1.2 s
1 s	1 to 12 s
0.1 m	0.1 to 1.2 min
1 m	1 to 12 min
0.1 h	0.1 to 1.2 h
1 h	1 to 12 h
10 h	10 to 120 h

Note: When the time setting dial is set to "0" for any time scale, the output will operate instantaneously.

■ Ratings

Rated supply voltage (see notes 1 and 2)	24 to 230 VAC (50/60 Hz)/24 to 48 VDC
Operating voltage range	85% to 110% of rated supply voltage
Power reset	Minimum power-off time: 0.1 s
Reset voltage	2.4 VAC/DC max.
Power consumption (see note 3)	AC: 32 VA max./3.0 W max. (typical: 30 VA/2.7 W) at 230 VAC 14 VA max./2.2 W max. (typical: 13 VA/2.1 W) at 100 to 120 VAC DC: 0.7 W max. (typical: 0.6 W) at 24 VDC 1.4 W max. (typical: 1.3 W) at 48 VDC
Voltage input	Max. permissible capacitance between inputs lines (terminals B1 and A2): 2,000 pF Load connectable in parallel with inputs (terminals B1 and A1). H-level: 20.4 to 253 VAC/20.4 to 52.8 VDC L-level: 0 to 2.4 VAC/DC
Control output	Contact output: 5 A at 250 VAC with resistive load ($\cos\phi = 1$) 5 A at 30 VDC with resistive load ($\cos\phi = 1$)
Ambient temperature	Operating: -10°C to 55°C (with no icing) Storage: -25°C to 65°C (with no icing)
Ambient humidity	Operating: 35% to 85%

Note: 1. DC ripple rate: 20% max.

- Since an inrush current of 0.5 A will occur when using the power supply voltage at 24 VDC, pay careful attention when turning on or off the power supply to the Timer with a solid-state output such as a sensor.
- The power consumption is for mode A after the Timer counts the time-up time and for the AC input at 50 Hz. The power consumption of the H3DS-ML includes the input circuit with the B1 and A1 terminals short-circuited.

■ Characteristics

Accuracy of operating time	±1% max. of FS (±1% ±10 ms max. at 1.2-s range)
Setting error	±10% ±50 ms max. of FS
Signal input time	50 ms min.
Influence of voltage	±0.7% max. of FS (±0.7% ±10 ms max. at 1.2-s range)
Influence of temperature	±5% max. of FS (±5% ±10 ms max. at 1.2-s range)
Insulation resistance	100 MΩ min. at 500 VDC
Dielectric strength	Between current-carrying metal parts and exposed non-current-carrying metal parts: 2,000 VAC for 1 min. Between control output terminals and operating circuit: 2,000 VAC for 1 min. Between contacts not located next to each other: 1,000 VAC for 1 min.
Vibration resistance	Malfunction: 0.5-mm single amplitude at 10 to 55 Hz Destruction: 0.75-mm single amplitude at 10 to 55 Hz
Shock resistance	Malfunction: 100 m/s ² 3 times each in 6 directions Destruction: 1,000 m/s ² 3 times each in 6 directions
Impulse withstand voltage	3 kV (between power terminals) 4.5 kV (between current-carrying metal parts and exposed non-current-carrying metal parts)
Noise immunity	Square-wave noise generated by noise simulator (pulse width: 100 ns/1 μs, 1-ns rise) ±1.5 kV
Static immunity	Malfunction: 4 kV Destruction: 8 kV
Life expectancy	Mechanical: 10 million operations min. (under no load at 1,800 operations/h) Electrical: 100,000 operations min. (5 A at 250 VAC, resistive load at 360 operations/h) (see note)
EMC	(EMI) EN61812-1 Emission Enclosure: EN55011 Group 1 class B Emission AC Mains: EN55011 Group 1 class B Harmonic Current: EN61000-3-2 Voltage Fluctuation and Flickering: EN61000-3-3 (EMS) EN61812-1 Immunity ESD: EN61000-4-2: 6 kV contact discharge (level 3) 8 kV air discharge (level 3) Immunity RF-interference from AM Radio Waves: EN61000-4-3: 10 V/m (80 MHz to 1 GHz) (level 3) Immunity Burst: EN61000-4-4: 2 kV power port and output port (level 3) 1 kV control port with capacitive clamp (level 3) Immunity Surge: EN61000-4-5: 2 kV common mode (level 3) 1 kV differential mode (level 3)
Case color	Light gray (5Y7/1)
Degree of protection	IP30 (Terminal block: IP20)
Weight	Approx. 70 g

Note: For reference:

A maximum current of 0.15 A can be switched at 125 VDC (cosφ=1).

A maximum current of 0.1 A can be switched if L/R is 7 ms.

In both cases, a life of 100,000 operations can be expected.

The minimum applicable load is 10 mA at 5 VDC (failure level: P).

Connections

■ Block Diagram

H3DS-ML□

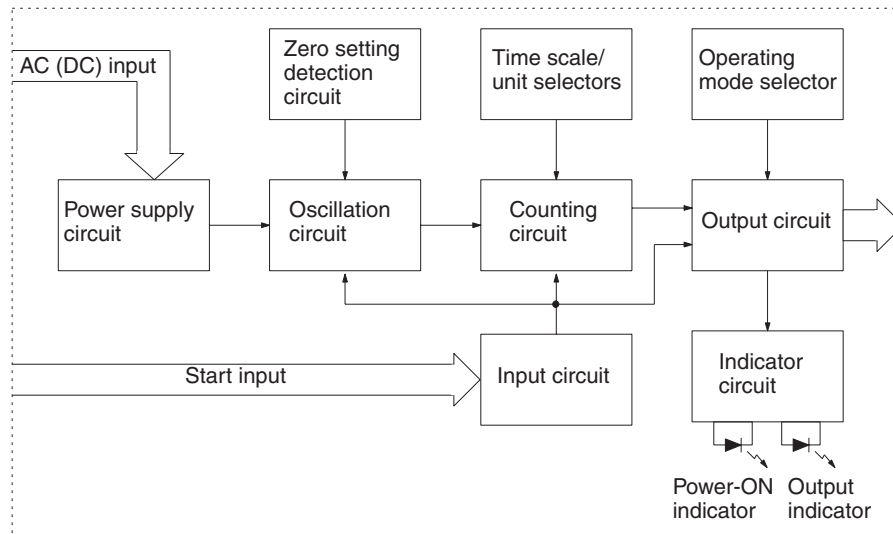

H3DS-SL□/-AL□

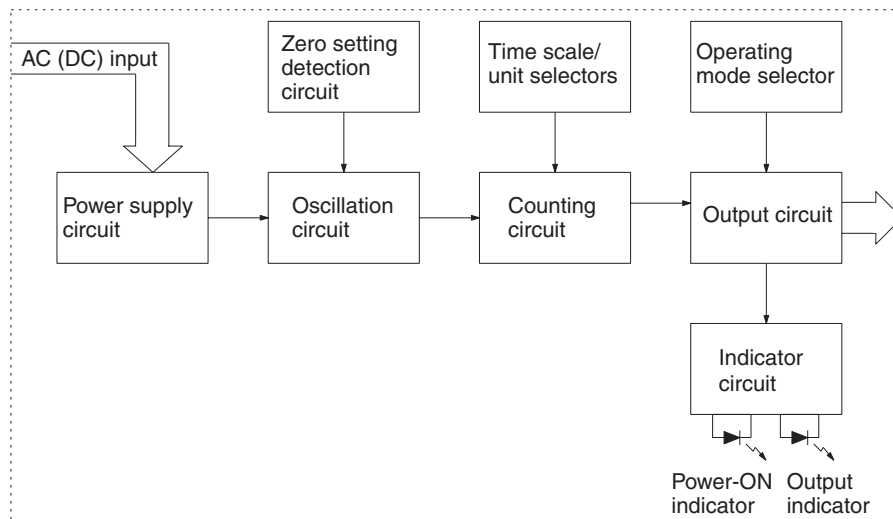

■ I/O Functions

Item		H3DS-ML□	H3DS-SL□/-AL□
Input	Start	Starts operation.	No input is available.
Output	Control output	Outputs are turned ON according to designated output mode when preset value is reached.	Outputs are turned ON according to designated output mode when preset value is reached.

Terminal Arrangement

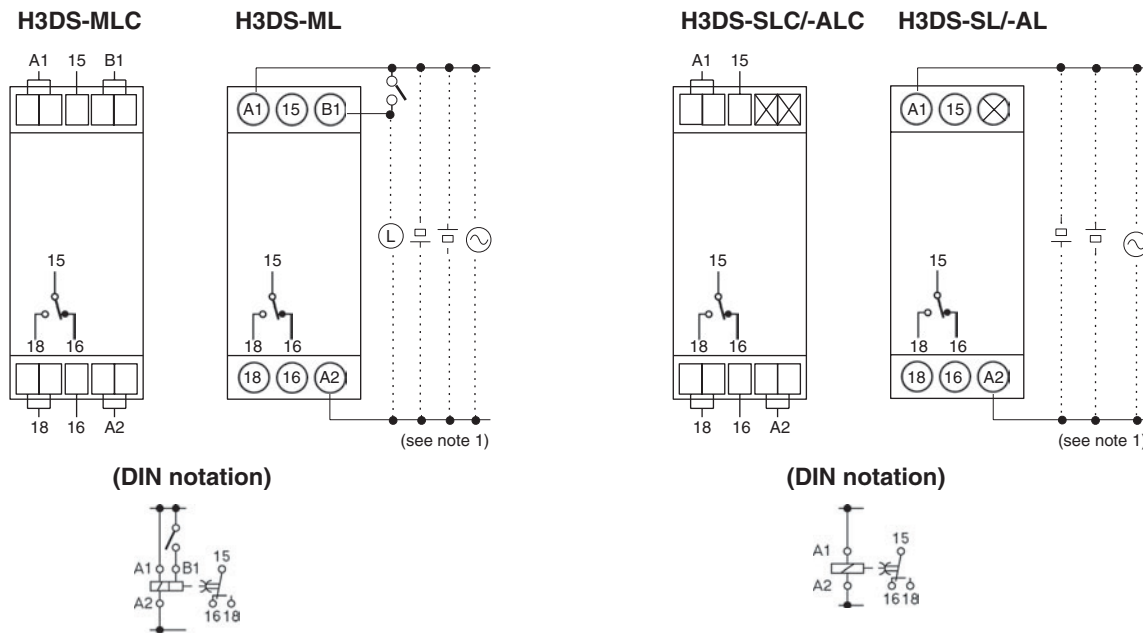

Note: 1. DC supply voltage does not require the designation of polarity.

2. The contact symbol for the H3DS is indicated with  because it offers multiple operating modes and is different from the delayed contact for conventional timers.

Input Connections

The inputs of the H3DS-ML□ are voltage (voltage imposition or open) inputs.

No-contact Input
(Connection to PNP output sensor.)

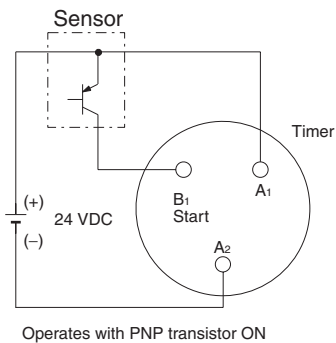

No-contact Input
(Connection to NPN output sensor.)

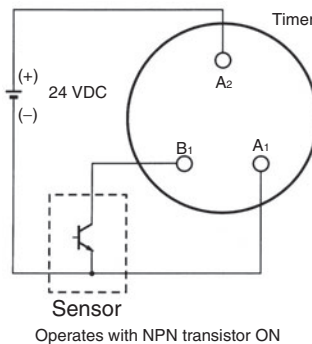

Contact Input

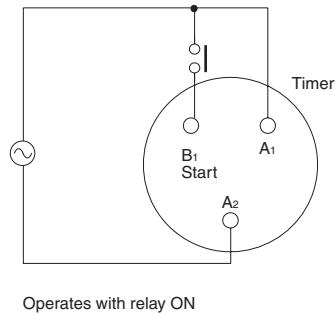

Voltage Input Signal Levels

No-contact input	1. Transistor ON Residual voltage: 1 V max. (Voltage between terminals B ₁ and A ₂ must be more than the rated "H-level" voltage (20.4 VDC min.).)
	2. Transistor OFF Leakage current: 0.01 mA max. (Voltage between terminals B ₁ and A ₂ must be less than the rated "L-level" voltage (2.4 VDC max.).)
Contact input	Use contacts that can adequately switch 0.1 mA at each voltage to be imposed. (When the contacts are ON or OFF, voltage between terminals B ₁ and A ₂ must be within the following ranges: When contacts are ON: 20.4 to 253 VAC/20.4 to 52.8 VDC When contacts are OFF: 0 to 2.4 VAC/DC)

Operation

■ Basic Operation

Setting of Selector

The selectors can be turned clockwise and counterclockwise to select the desired time scale, or operating mode.

Each selector has a snap mechanism that secures the selector at a given position. Set the selector at a position at which it is secured. Do not set it midway between two securing positions or a malfunction could result from improper setting.

Selection of Operating Mode (except for H3DS-AL)

The H3DS-ML/-SL can be set to any one of the operating modes A to J. Turn the operating mode selector with a screwdriver until the desired operating mode appears in the operating mode display window.

H3DS-ML (8 modes): A, B, B2, C, D, E, G, J
(In order of appearance)

H3DS-SL (4 modes): A, E, B2, J, E, E, J, J
(In order of appearance)

Note: Letters that appear more than once indicate exactly the same operating mode.

Selection of Time Scale

The time scale is selected by turning the time scale selector. The time scales will appear in the following order in the time scale display window on the left of the selector:

1 s, 0.1 s, 1 h, 0.1 h, 10 h, 1 h, 1 m, 0.1 m.

Note: The time scale "1h" appears twice. Both instances indicate exactly the same time scale.

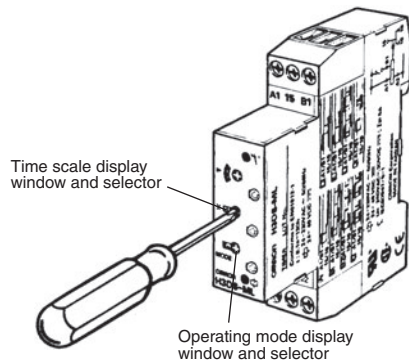

Locking/Unlocking of Selectors and Time Setting Dial

The time setting dial, time scale selector, and operating mode selector can be locked using the Y92S-38 Lock Key, a special pen type tool that is sold separately. To lock the dial or selectors, insert the Lock Key in the keyhole to the lower right of the dial or selector and turn it clockwise until the dial or selector is completely covered with the red cover. To unlock, turn the Lock Key in the opposite direction.

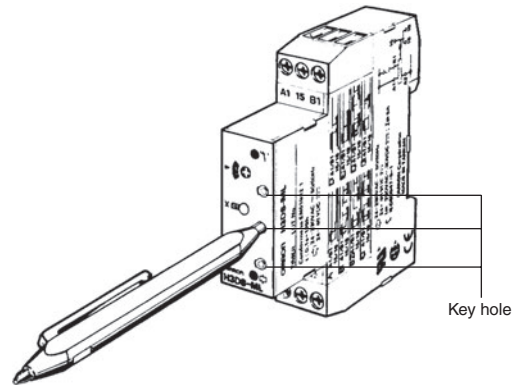

Timing Chart

- Note:**
- The minimum power reset time is 0.1 s and the minimum signal input time is 0.05 s.
 - The letter "t" in the timing charts stands for the set time and "t-a" means that the period is less than the time set.
 - There is no start input for H3DS-SL□/-AL□ models. Operation starts at power-on.

Operating mode	Timing chart	
A: ON-delay		<p>Basic operation</p> <p>* For power-on operation, impose voltage to the Start input. The Timer starts operating at the moment the power is turned on. ** Start input is invalid while the Timer is in operation.</p>
B: Flicker OFF start		<p>Basic operation</p> <p>* For power-on operation, impose voltage to the Start input. The Timer starts operating at the moment the power is turned on. ** Start input is invalid while the Timer is in operation.</p>
B2: Flicker ON start		<p>Basic operation</p> <p>* For power-on operation, impose voltage to the Start input. The Timer starts operating at the moment the power is turned on. ** Start input is invalid while the Timer is in operation.</p>
C: Signal ON/OFF-delay		<p>Basic operation</p> <p>* Start input is invalid while the Timer is in operation.</p>

Note: The start input of the H3DS-ML□ model is activated by applying a voltage to B1 and A2 terminals. The voltage can be applied by turning on the contact between B1 and A1 (Refer to *Terminal Arrangement*).

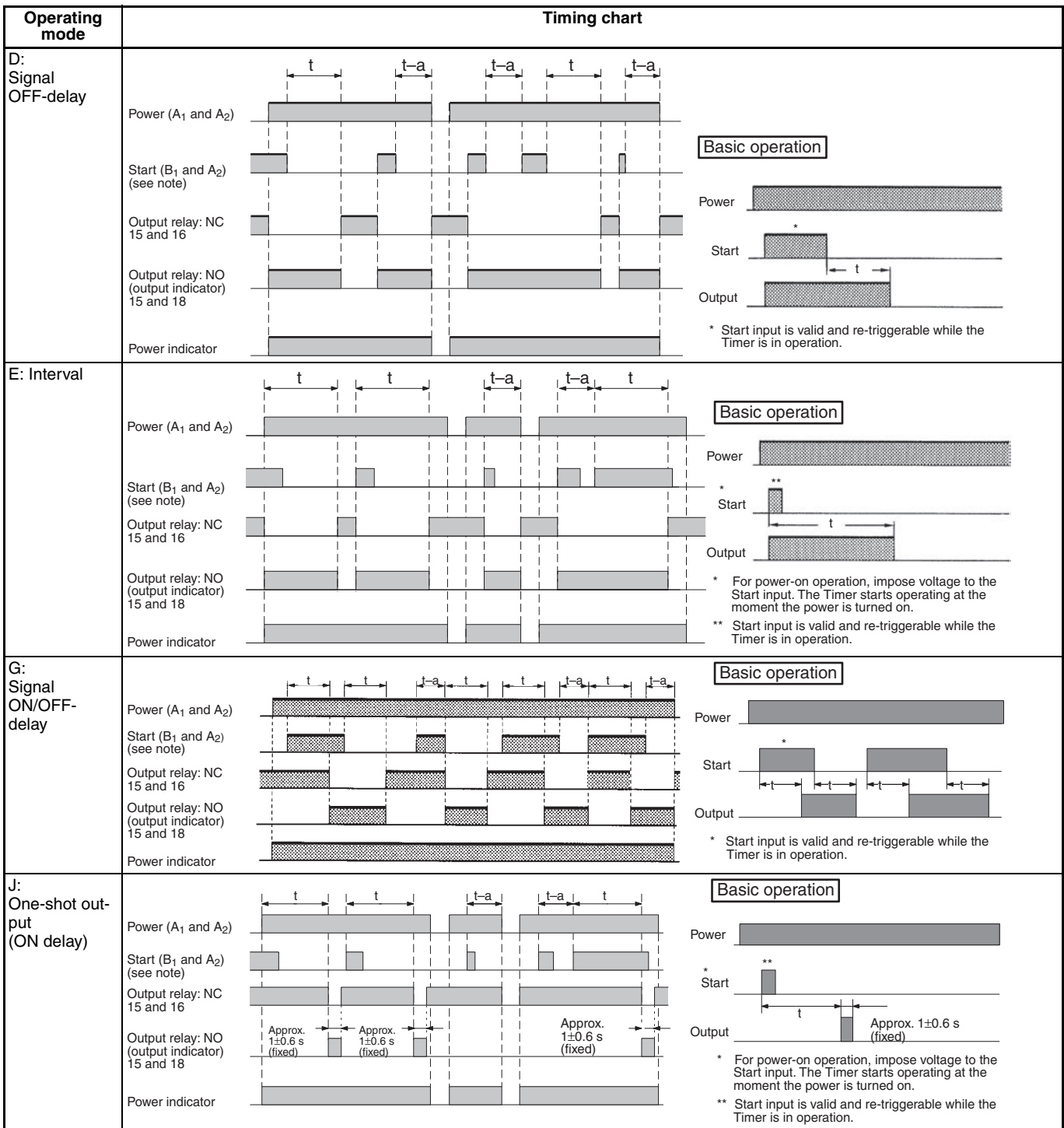

Note: The start input of the H3DS-ML□ model is activated by applying a voltage to B1 and A2 terminals. The voltage can be applied by turning on the contact between B1 and A1 (Refer to *Terminal Arrangement*).

Nomenclature

H3DS-ML□/-SL□

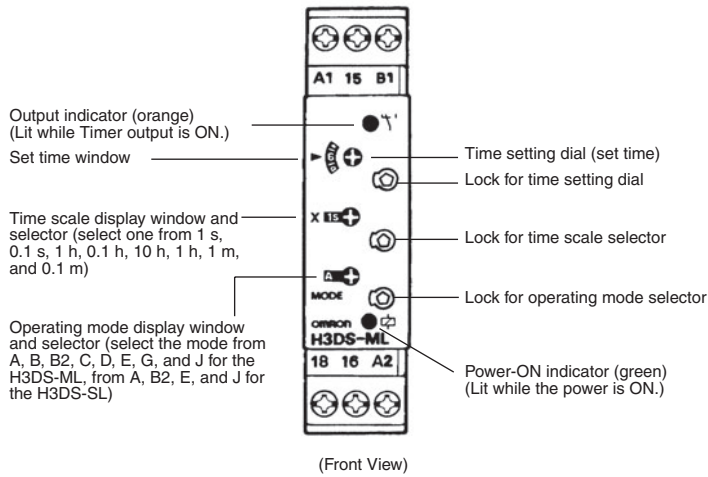

H3DS-MLC/-SLC

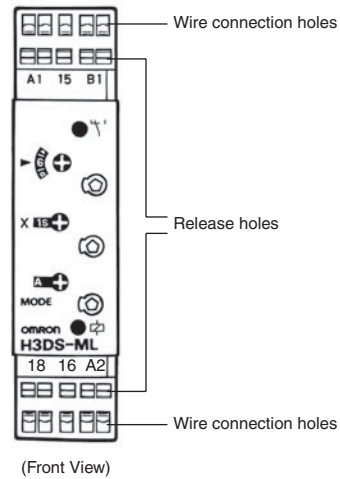

H3DS-AL□

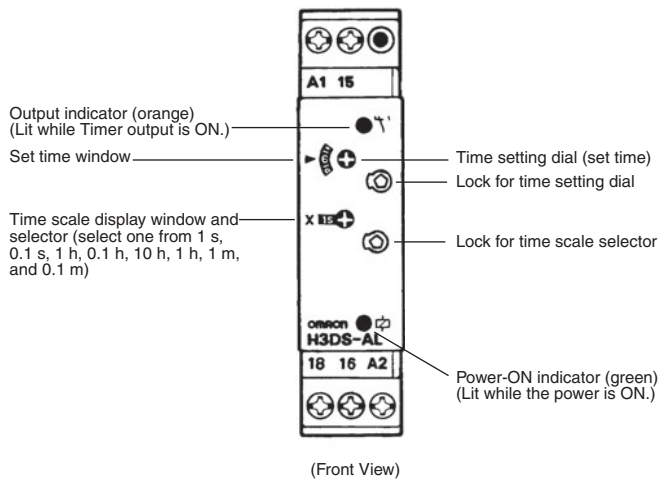

H3DS-ALC

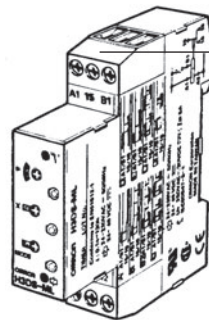
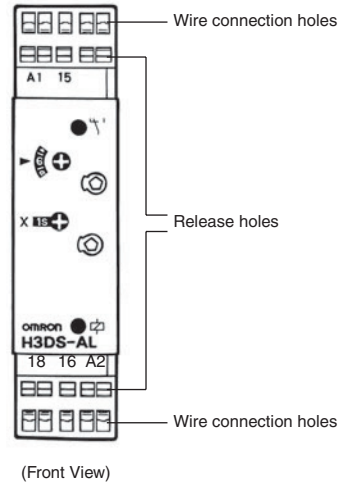

Attach the enclosed label here as a nameplate.
(The label is attached to the Timer's DIN Track hook section at the time of shipment.)

Dimensions

Note: All units are in millimeters unless otherwise indicated.

H3DS-ML/-SL/-AL

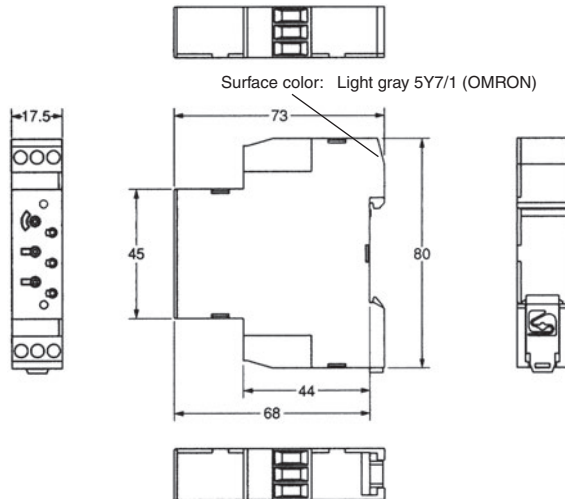
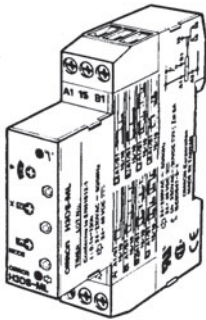

H3DS-MLC/-SLC/-ALC

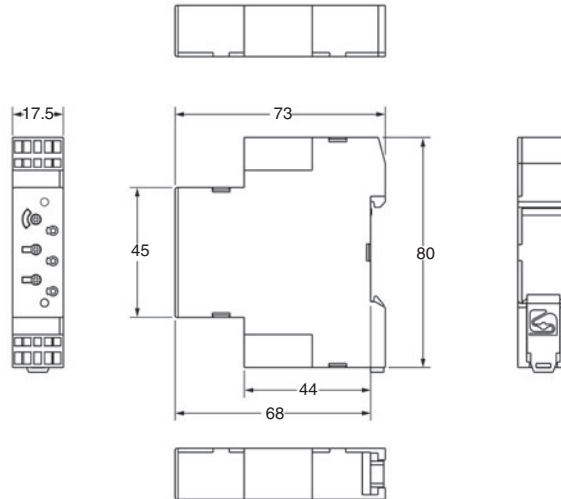
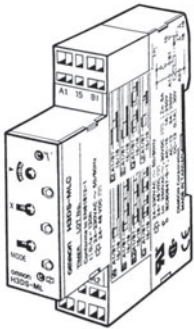

ALL DIMENSIONS SHOWN ARE IN MILLIMETERS.
 To convert millimeters into inches, multiply by 0.03937. To convert grams into ounces, multiply by 0.03527.

In the interest of product improvement, specifications are subject to change without notice.

Solid-state Twin Timer H3DS-F

- Operates in flicker-OFF or flicker-ON start mode with one Unit.
- Independent ON- and OFF-time settings.
Combinations of long ON- or OFF-time and short OFF- or ON-time setting are possible.
- Long time range from 0.1 s to 12 h for both ON and OFF time settings.



Model Number Structure

Model Number Legend

H3DS -F L □
1 2 3

1. F: Twin timers
2. L: Smart lock mechanism
3. None: Screw terminal type
C: Screw-Less Clamp type

Ordering Information

List of Models

Operating mode	Supply voltage	Model	
		Screw terminal type	Screw-Less Clamp type
Flicker-OFF/Flicker-ON start	24 to 230 VAC (50/60 Hz)/24 to 48 VDC	H3DS-FL	H3DS-FLC

Accessories (Order Separately)

Lock Key		Y92S-38
Mounting Track	50 cm (l) x 7.3 mm (t)	PFP-50N
	1 m (l) x 7.3 mm (t)	PFP-100N
	1 m (l) x 16 mm (t)	PFP-100N2
End Plate		PFP-M
Spacer		PEP-S

Specifications

■ General

Item	H3DS-F
Operating mode	Flicker-OFF/Flicker-ON start
Output type	Relay: SPDT
External connections	Screw terminal, Screw-Less Clamp
Terminal block	Screw terminal type: Clamps two 2.5-mm ² max. bar terminals without sleeves. Screw-Less Clamp type: Clamps two 1.5-mm ² max. bar terminals without sleeves.
Terminal screw tightening torque	0.98 N·m max.
Mounting method	DIN track mounting (see note)
Attachment	Nameplate label
Approved standards	UL508, CSA C22.2 No.14 Conforms to EN61812-1, IEC60664-1 4 kV/2, VDE0106/P 100 Output category according to IEC60947-5-1 (AC-13; 250 V 5A/AC-15; 250 V 1 A/DC-13; 30 V 0.1 A)

Note: Can be mounted to 35-mm DIN Track with a plate thickness of 1 to 2.5 mm.

■ Time Ranges

Time scale display	Time range
0.1 s	0.1 to 1.2 s
1 s	1 to 12 s
0.1 m	0.1 to 1.2 min
1 m	1 to 12 min
0.1 h	0.1 to 1.2 h
1 h	1 to 12 h

Note: When the time setting dial is set to "0" for any time scale, the output will operate instantaneously.

■ Ratings

Rated supply voltage (See note.)	24 to 230 VAC (50/60 Hz)/24 to 48 VDC
Operating voltage range	85% to 110% of rated supply voltage
Power reset	Minimum power-off time: 0.1 s
Reset voltage	2.4 VAC/DC max.
Power consumption	AC: 33 VA max./2.2 W max. (typical: 31 VA/2.0 W) at 230 VAC 11 VA max./1.9 W max. (typical: 9.7 VA/1.7 W) at 100 to 120 VAC DC: 0.7 W max. (typical: 0.6 W) at 24 VDC 1.4 W max. (typical: 1.2 W) at 48 VDC
Voltage input	Max. permissible capacitance between inputs lines (terminals B1 and A2): 2,000 pF Load connectable in parallel with inputs (terminals B1 and A1). H-level: 20.4 to 253 VAC/20.4 to 52.8 VDC L-level: 0 to 2.4 VAC/DC
Control output	Contact output: 5 A at 250 VAC with resistive load ($\cos\phi = 1$) 5 A at 30 VDC with resistive load ($\cos\phi = 1$)
Ambient temperature	Operating: -10°C to 55°C (with no icing) Storage: -25°C to 65°C (with no icing)
Ambient humidity	Operating: 35% to 85%

Note: DC ripple rate: 20% max.

■ Characteristics

Accuracy of operating time	±1% max. of FS (±1% ±10 ms max. at 1.2-s range)
Setting error	±10% ± 50 ms max. of FS
Influence of voltage	±0.5% max. of FS (±0.5% ±10 ms max. at 1.2-s range)
Influence of temperature	±5% max. of FS (±5% ± 10 ms max. at 1.2-s range)
Insulation resistance	100 MΩ min. at 500 VDC
Dielectric strength	Between current-carrying metal parts and exposed non-current-carrying metal parts: 2,000 VAC (50/60 Hz) for 1 min. Between control output terminals and operating circuit: 2,000 VAC (50/60 Hz) for 1 min. Between contacts not located next to each other: 1,000 VAC (50/60 Hz) for 1 min.
Impulse withstand voltage	3 kV (between power supply terminals) 4.5 kV (between current-carrying metal parts and exposed non-current-carrying metal parts)
Noise immunity	Square-wave noise generated by noise simulator (pulse width: 100 ns/1 μs, 1-ns rise) ±1.5 kV
Static immunity	Malfunction: 4 kV Destruction: 8 kV
Vibration resistance	Malfunction: 0.5-mm single amplitude at 10 to 55 Hz Destruction: 0.75-mm single amplitude at 10 to 55 Hz
Shock resistance	Malfunction: 200 m/s ² , 3 times each in 6 directions Destruction: 300 m/s ² , 3 times each in 6 directions
Life expectancy	Mechanical: 10 million operations min. (under no load at 1,800 operations/h) Electrical: 100,000 operations min. (5 A at 250 VAC, resistive load at 360 operations/h) (see note)
EMC	(EMI) EN61812-1 Emission Enclosure: EN55011 Group 1 class B Emission AC Mains: EN55011 Group 1 class B Harmonic Current: EN61000-3-2 Voltage Fluctuation and Flickering: EN61000-3-3 (EMS) EN61812-1 Immunity ESD: EN61000-4-2: 6 kV contact discharge (level 3) 8 kV air discharge (level 3) Immunity RF-interference from AM Radio Waves: EN61000-4-3: 10 V/m (80 MHz to 1 GHz) (level 3) Immunity Burst: EN61000-4-4: 2 kV power port and output port (level 3) 1 kV control port with capacitive clamp (level 3) Immunity Surge: EN61000-4-5: 2 kV common mode (level 3) 1 kV differential mode (level 3)
Case color	Light gray (5Y7/1)
Degree of protection	IP30 (IP20 for terminal block)
Weight	Approx. 70 g

Note: For reference:

A maximum current of 0.15 A can be switched at 125 VDC (cosφ=1).

A maximum current of 0.1 A can be switched if L/R is 7 ms.

In both cases, a life of 100,000 operations can be expected.

The minimum applicable load is 10 mA at 5 VDC (failure level: P).

Connections

■ Block Diagram

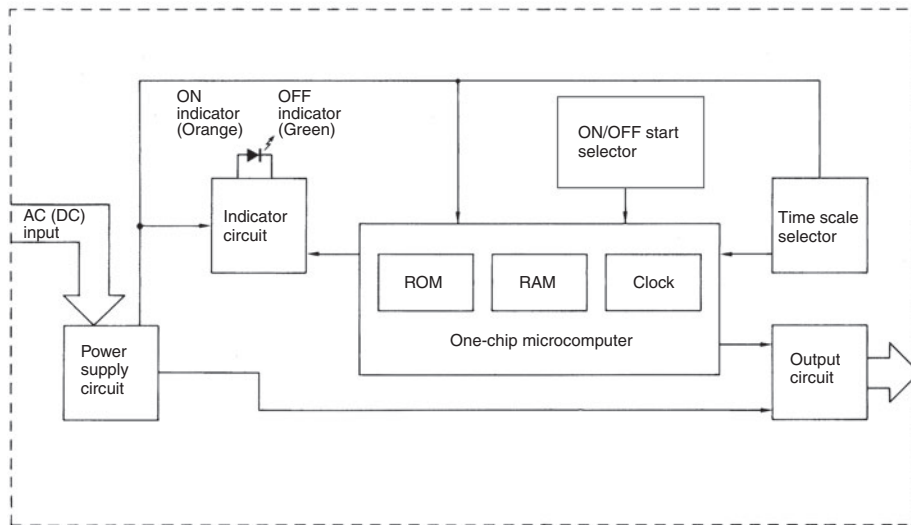

■ I/O Function

Inputs	Flicker-ON start operation begins when inputs are turned ON.	
Outputs	Control output	Outputs are turned ON/OFF according to the time set by the ON-and OFF-time setting dial.

■ Terminal Arrangement

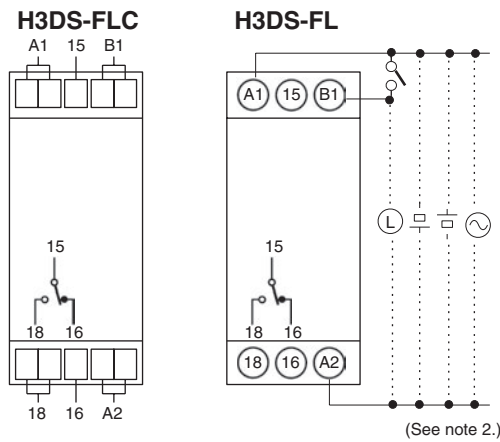

- Note:** 1. If voltage is applied to terminal B1, or if terminals A1 and B1 are shorted, the operating mode is switched to flicker-ON start mode. If these terminals are disconnected, the mode switches to flicker-OFF start mode.
 2. DC supply voltage does not require the designation of polarity.

Operation

Basic Operation

Setting of Selector

The selectors can be turned clockwise and counterclockwise to select the desired time scale, or operating mode.

Each selector has a snap mechanism that secures the selector at a given position. Set the selector at a position at which it is secured. Do not set it midway between two securing positions or a malfunction could result from improper setting.

Settings for ON/OFF Start

If voltage is applied to terminal B1, or if terminals A1 and B1 are shorted, the operating mode is switched to flicker-ON start mode. If these terminals are disconnected, the mode switches to flicker-OFF start mode. The operating mode will not change if the state of the applied voltage changes during timer operation.

Selection of Time Scale

The time scale is selected by turning the ON-time scale selector and OFF-time scale selector. The time scales will appear in the following order in each time scale display window on the left of the selector:

0.1 s, 1 h, 0.1 h, 1 m, 1 s, 0.1 h, 0.1 m, 1 s.

Note: The time scales "1 s" and "0.1 h" appear twice. Both instances indicate exactly the same time scale.

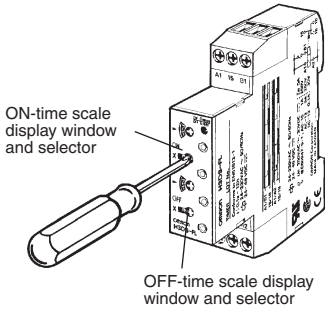

Time Setting

Use the ON/OFF-time setting dials to set the ON/OFF time.

Locking/Unlocking of Selectors and Time Setting Dial

The ON/OFF-time setting dials and time scale selectors can be locked using the Y92S-38 Lock Key, a special pen type tool that is sold separately. To lock the dials or selectors, insert the Lock Key in the keyhole to the lower right of the dial or selector and turn it clockwise until the dial or selector is completely covered with the red cover. To unlock, turn the Lock Key in the opposite direction.

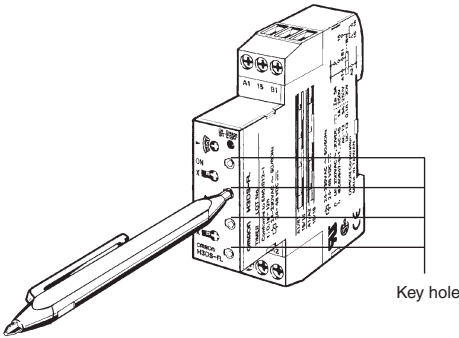

Timing Charts

Operating mode	Timing chart	
Flicker-OFF start (See note 1.)	<p>Power (A₁ and A₂)</p> <p>Output relay: NO 15 and 18 (ON indicator)</p> <p>Output relay: NC 15 and 16</p> <p>OFF indicator</p>	<p>ON OFF</p> <p>ON OFF</p> <p>ON OFF</p> <p>ON OFF</p> <p>0.1 s min.</p> <p>t_{ON}: ON set time t_{OFF}: OFF set time</p>
Flicker-ON start (See note 1.)	<p>Power (A₁ and A₂)</p> <p>Signal (B₁ and A₂)</p> <p>Output relay: NO 15 and 18 (ON indicator)</p> <p>Output relay: NC 15 and 16</p> <p>OFF indicator</p>	<p>ON OFF</p> <p>ON OFF</p> <p>ON OFF</p> <p>ON OFF</p> <p>ON OFF</p> <p>0.1 s min.</p> <p>t_{ON}: ON set time t_{OFF}: OFF set time</p>

- Note:**
- If voltage is applied to terminal B1, or if terminals A1 and B1 are shorted, the operating mode is switched to flicker-ON start mode. If these terminals are disconnected, the mode switches to flicker-OFF start mode.
 - The reset time requires a minimum of 0.1 s.
 - When power is supplied in flicker-ON start mode, the OFF indicator lights momentarily. This, however, has no effect on the performance of the Timer.

Nomenclature

H3DS-FL□

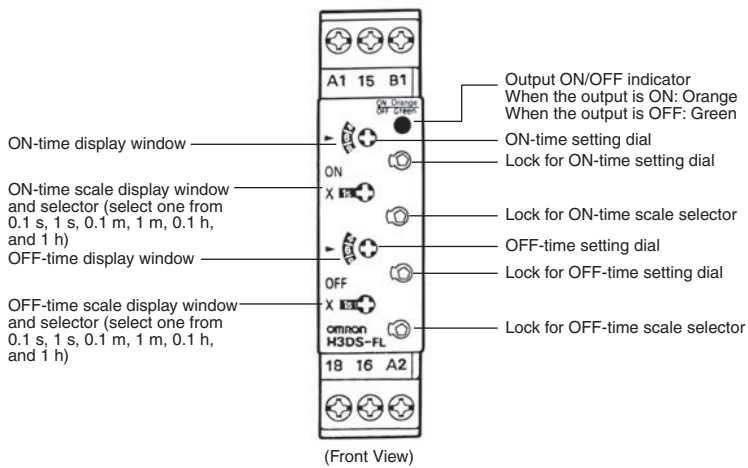

H3DS-FLC

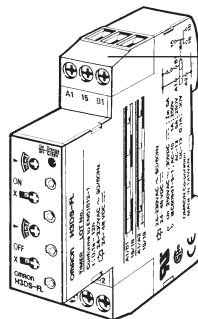
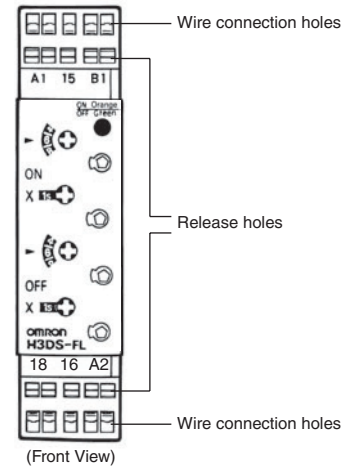

Attach the enclosed label here as a nameplate.
(The label is attached to the Timer's DIN Track hook section at the time of shipment.)

Dimensions

H3DS-FL

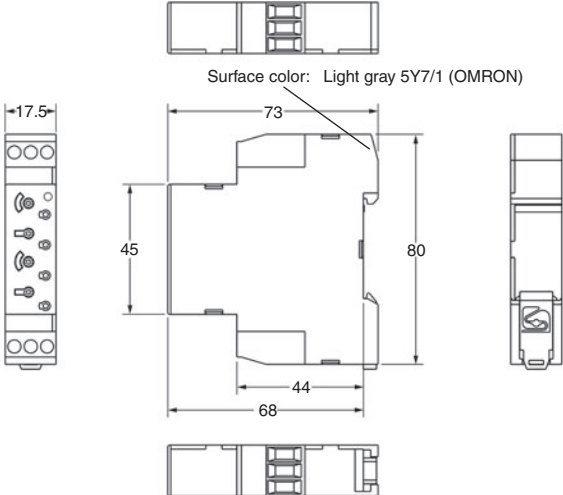
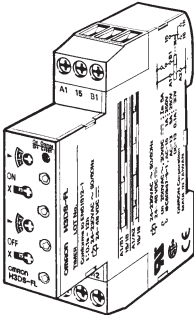

H3DS-FLC

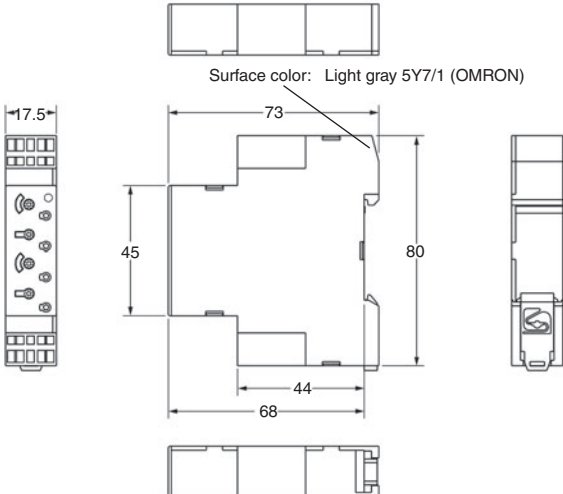
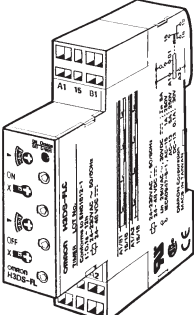

ALL DIMENSIONS SHOWN ARE IN MILLIMETERS.
 To convert millimeters into inches, multiply by 0.03937. To convert grams into ounces, multiply by 0.03527.

In the interest of product improvement, specifications are subject to change without notice.

- A wide star-time range (up to 120 seconds) and star-delta transfer time range (up to 1 second)



Model Number Structure

Model Number Legend

H3DS -G L □
1 2 3

1. G: Star-delta timer
2. L: Smart lock mechanism
3. None: Screw terminal type
C: Screw-Less Clamp type

Ordering Information

List of Models

Operating mode	Supply voltage	Model	
		Screw terminal type	Screw-Less Clamp type
Star-delta operation	24 to 230 VAC (50/60 Hz)/24 to 48 VDC	H3DS-GL	H3DS-GLC

Accessories (Order Separately)

Lock Key		Y92S-38
Mounting Track	50 cm (l) x 7.3 mm (t)	PFP-50N
	1 m (l) x 7.3 mm (t)	PFP-100N
	1 m (l) x 16 mm (t)	PFP-100N2
End Plate		PFP-M
Spacer		PEP-S

Specifications

■ General

Item	H3DS-G
Operating mode	Star-delta operation
Operating/Reset method	Time-limit operation/Self-reset
External connections	Screw terminal, Screw-Less Clamp
Terminal block	Screw terminal type: Clamps two 2.5-mm ² max. bar terminals without sleeves. Screw-Less Clamp type: Clamps two 1.5-mm ² max. bar terminals without sleeves.
Terminal screw tightening torque	0.98 N·m max.
Output type	(Star operation circuit) Relay: SPST-NO (Delta operation circuit) Relay: SPST-NO
Mounting method	DIN track mounting (see note)
Attachment	Nameplate label
Approved standards	UL508, CSA C22.2 No.14 Conforms to EN61812-1, IEC60664-1 4 kV/2, VDE0106/P100 Output category according to IEC60947-5-1 (AC-13; 250 V 5A/AC-15; 250 V 1 A/DC-13; 30 V 0.1 A)

Note: Can be mounted to 35-mm DIN Track with a plate thickness of 1 to 2.5 mm.

■ Time Ranges

Time scale	Star operation time ranges
x 1	1 to 12 s
x 10	10 to 120 s

Star-delta transfer time	Programmable at 0.05 s, 0.1 s, 0.5 s, or 1 s
--------------------------	--

■ Ratings

Rated supply voltage (see note)	24 to 230 VAC (50/60 Hz)/24 to 48 VDC
Operating voltage range	85% to 110% of rated supply voltage
Power reset	Minimum power-off time: 0.5 s
Reset voltage	2.4 VAC/DC max.
Power consumption	AC: 21 VA max./1.7 W max. (typical: 20 VA/1.6 W) at 230 VAC 11 VA max./2.0 W max. (typical: 8.6 VA/1.5 W) at 100 to 120 VAC DC: 1.3 W max. (typical: 1.2 W) at 24 VDC 0.7 W max. (typical: 0.6 W) at 48 VDC
Control output	Contact output: 5 A at 250 VAC with resistive load ($\cos\phi = 1$) 5 A at 30 VDC with resistive load ($\cos\phi = 1$)
Ambient temperature	Operating: -10°C to 55°C (with no icing) Storage: -25°C to 65°C (with no icing)
Ambient humidity	Operating: 35% to 85%

Note: DC ripple rate: 20% max.

■ Characteristics

Accuracy of operating time	±1% max. of FS
Setting error	±10% ± 50 ms max. of FS
Total tolerance of transfer time	± (25% FS + 5 ms) max.
Influence of voltage	±0.5% max. of FS
Influence of temperature	±5% max. of FS
Insulation resistance	100 MΩ min. at 500 VDC
Dielectric strength	Between current-carrying metal parts and exposed non-current-carrying metal parts: 2,000 VAC (50/60 Hz) for 1 min. Between control output terminals and operating circuit: 2,000 VAC (50/60 Hz) for 1 min. Between contacts not located next to each other: 1,000 VAC (50/60 Hz) for 1 min.
Impulse withstand voltage	3 kV (between power supply terminals) 4.5 kV (between current-carrying metal parts and exposed non-current-carrying metal parts)
Noise immunity	Square-wave noise generated by noise simulator (pulse width: 100 ns/1 μs, 1-ns rise) ±1.5 kV
Static immunity	Malfunction: 4 kV Destruction: 8 kV
Vibration resistance	Malfunction: 0.5-mm single amplitude at 10 to 55 Hz Destruction: 0.75-mm single amplitude at 10 to 55 Hz
Shock resistance	Malfunction: 200 m/s ² , 3 times each in 6 directions Destruction: 300 m/s ² , 3 times each in 6 directions
Life expectancy	Mechanical: 10 million operations min. (under no load at 1,800 operations/h) Electrical: 100,000 operations min. (5 A at 250 VAC, resistive load at 360 operations/h) (see note)
EMC	(EMI) Emission Enclosure: EN61812-1 Emission AC Mains: EN55011 Group 1 class B Harmonic Current: EN55011 Group 1 class B Voltage Fluctuation and Flickering: EN61000-3-2 (EMS) Immunity ESD: EN61812-1 EN61000-4-2: 6 kV contact discharge (level 3) 8 kV air discharge (level 3) Immunity RF-interference from AM Radio Waves: EN61000-4-3: 10 V/m (80 MHz to 1 GHz) (level 3) Immunity Burst: EN61000-4-4: 2 kV power port and output port (level 3) 1 kV control port with capacitive clamp (level 3) Immunity Surge: EN61000-4-5: 2 kV common mode (level 3) 1 kV differential mode (level 3)
Case color	Light gray (5Y7/1)
Degree of protection	IP30 (IP20 for terminal block)
Weight	Approx. 70 g

Note: For reference:

A maximum current of 0.15 A can be switched at 125 VDC (cosφ=1).

A maximum current of 0.1 A can be switched if L/R is 7 ms.

In both cases, a life of 100,000 operations can be expected.

The minimum applicable load is 10 mA at 5 VDC (failure level: P).

Connections

■ Block Diagram

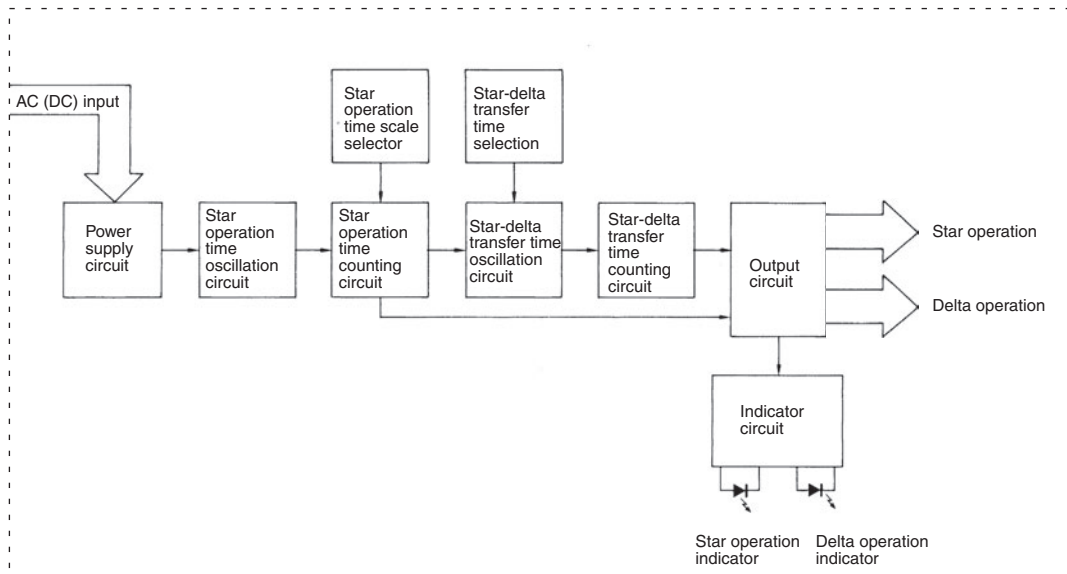

■ I/O Functions

Inputs	---	
Outputs	Control output	Star output is turned OFF when the dial set value is reached and delta output is ON after the preset transfer time elapses

■ Terminal Arrangement

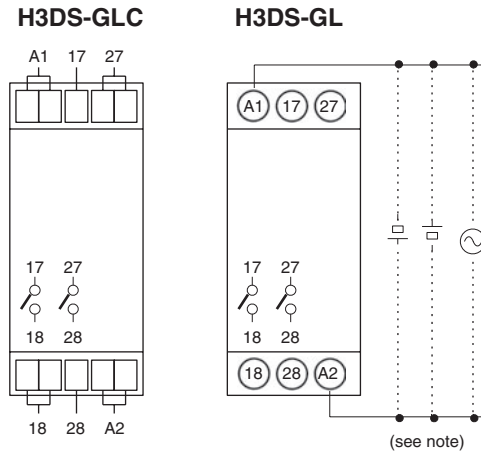

Note: DC supply voltage does not require the designation of polarity.

Operation

Basic Operation

Setting of Selector

The selectors can be turned clockwise and counterclockwise to select the desired time scale, or operating mode.

Each selector has a snap mechanism that secures the selector at a given position. Set the selector at a position at which it is secured. Do not set it midway between two securing positions or a malfunction could result from improper setting.

Selection of Time Unit and Time Scale

The star-delta transfer time and star operation time scale are set with the same selector. The star-delta transfer time can be set to 0.05, 0.1, 0.5, or 1. The star operation time scale can be set to a multiplication factor of 1 or 10. If the star-delta transfer time is displayed in the display window in white letters, this means that the star operation time scale is "x10". Refer to the example below.

Star-delta transfer time	Star operation time scale
0.05 s	x1
0.1 s	
0.5 s	
1 s	
0.05 s	x10
0.1 s	
0.5 s	
1 s	

Time Setting

The star operation time of the Timer is set with the time setting dial.

Locking/Unlocking of Selectors and Time Setting Dial

The time setting dial and time scale selector can be locked using the Y92S-38 Lock Key, a special pen type tool that is sold separately. To lock the dial or selectors, insert the Lock Key in the keyhole to the lower right of the dial or selector and turn it clockwise until the dial or selector is completely covered with the red cover. To unlock, turn the Lock Key in the opposite direction.

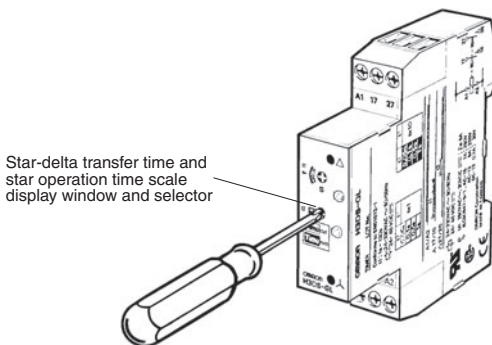
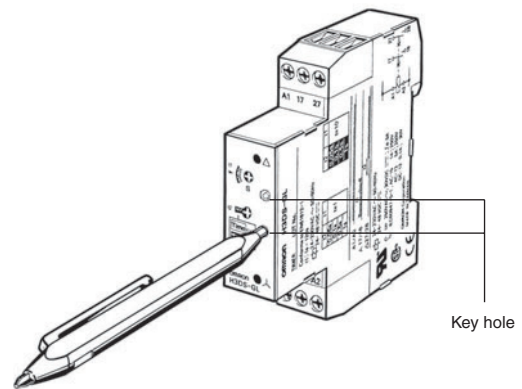

Timing Charts

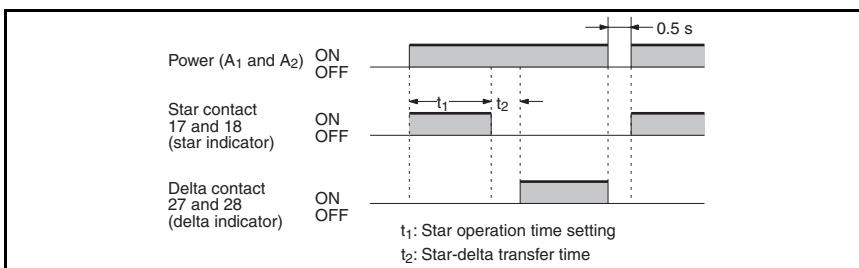

Note: The reset time requires a maximum of 0.5 s.

Nomenclature

H3DS-GL□

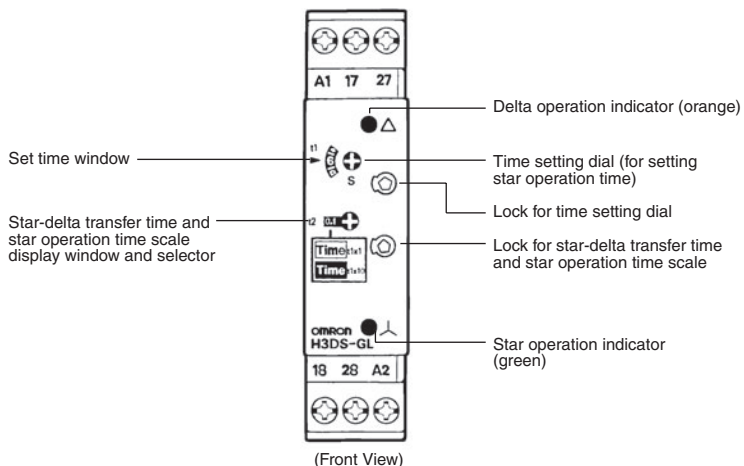

H3DS-GLC

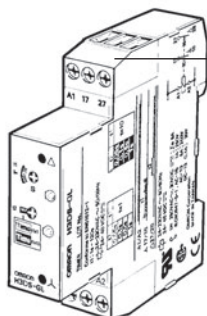
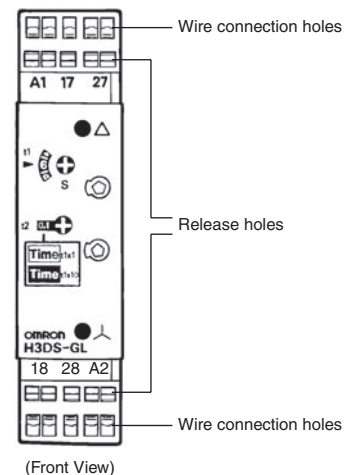

Attach the enclosed label here as a nameplate. (The label is attached to the Timer's DIN Track hook section at the time of shipment.)

Dimensions

H3DS-GL

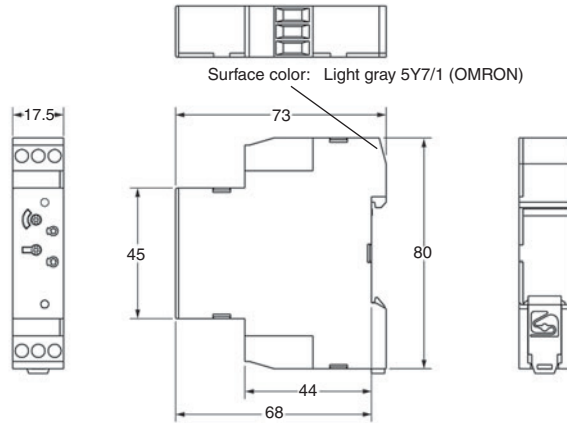
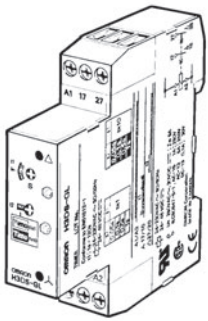

H3DS-GLC

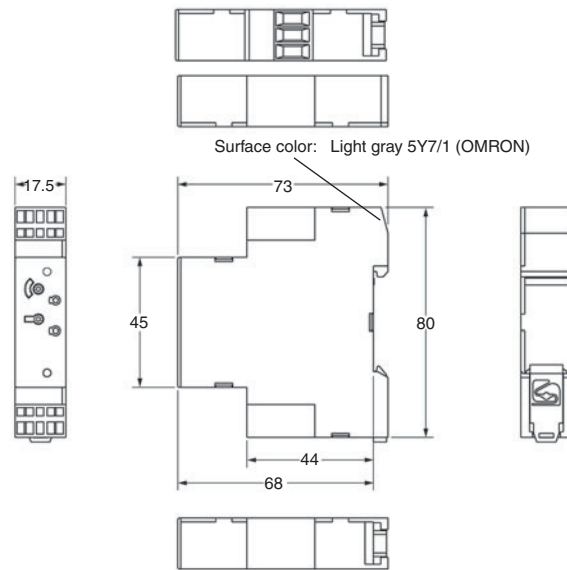
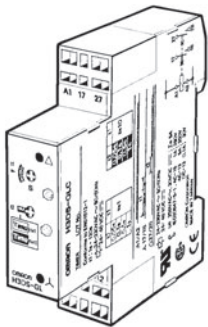

ALL DIMENSIONS SHOWN ARE IN MILLIMETERS.
 To convert millimeters into inches, multiply by 0.03937. To convert grams into ounces, multiply by 0.03527.

In the interest of product improvement, specifications are subject to change without notice.

H3DS-X

- Covers wide range of supply voltage (24 to 230 VAC/VDC).



Model Number Structure

Model Number Legend

H3DS -X L □
1 2 3

- 1. X: Two-wired timer
- 2. L: Smart lock mechanism
- 3. None: Screw terminal type
C: Screw-Less Clamp type

Ordering Information

List of Models

Supply voltage	Input type	Operating mode	Model	
			Screw terminal type	Screw-Less Clamp type
24 to 230 VAC/VDC (50/60 Hz)	No-input available	ON-delay	H3DS-XL	H3DS-XLC

Accessories (Order Separately)

Lock Key		Y92S-38
Mounting Track	50 cm (l) x 7.3 mm (t)	PFP-50N
	1 m (l) x 7.3 mm (t)	PFP-100N
	1 m (l) x 16 mm (t)	PFP-100N2
End Plate		PFP-M
Spacer		PEP-S

Specifications

■ General

Item	H3DS-X
Operating mode	ON-delay
Operating/Reset method	Time-limit operation/self-resetting
Output type	SCR output
External connections	Screw terminal, Screw-Less Clamp
Terminal block	Screw terminal type: Clamps two 2.5-mm ² max. bar terminals without sleeves. Screw-Less Clamp type: Clamps two 1.5-mm ² max. bar terminals without sleeves.
Terminal screw tightening torque	0.98 N·m max.
Mounting method	DIN track mounting (see note)
Attachment	Nameplate label
Approved standards	UL508, CSA C22.2 No.14 Conforms to EN61812-1, IEC60664-1 4 kV/2, VDE0106/P100

Note: Can be mounted to 35-mm DIN Track with a plate thickness of 1 to 2.5 mm.

■ Time Ranges

Time scale display	Time range
0.1 s	0.1 to 1.2 s
1 s	1 to 12 s
0.1 m	0.1 to 1.2 min
1 m	1 to 12 min
0.1 h	0.1 to 1.2 h
1 h	1 to 12 h
10 h	10 to 120 h

Note: When the time setting dial is set to "0" for any time scale, the output will operate instantaneously.

■ Ratings

Rated supply voltage (see note)	24 to 230 VAC/VDC (50/60 Hz)
Operating voltage range	85% to 110% of rated supply voltage
Power reset	Minimum power-off time: 0.1 s
Reset voltage	1.0 VAC/VDC max.
Reset current	5 mA max.
Power consumption	5 mA max.
Control output	SCR output: 5 mA to 0.7 A
Ambient temperature	Operating: -10°C to 55°C (with no icing) Storage: -25°C to 65°C (with no icing)
Ambient humidity	Operating: 35% to 85%

Note: The ripple in DC power supply must be 5% max.

■ Characteristics

Accuracy of operating time	±1% max. of FS (±1% ±10 ms max. at 1.2-s range)
Setting error	±10% ± 50 ms max. of FS
Reset time	0.1 s max.
Influence of voltage	±0.5% max. of FS (±0.5%±10 ms max. at 1.2-s range)
Influence of temperature	±5% max. of FS (±5%±10 ms max. at 1.2-s range)
Insulation resistance	100 MΩ min. at 500 VDC
Dielectric strength	Between current-carrying metal parts and exposed non-current-carrying metal parts: 2,000 VAC for 1 min
Impulse withstand voltage	3 kV (between power supply terminals) 4.5 kV (between current-carrying metal parts and exposed non-current-carrying metal parts)
Noise immunity	Square-wave noise generated by noise simulator (pulse width: 100 ns/1 μs, 1-ns rise) ±1.5 kV (between power supply terminals)
Static immunity	Malfunction: 4 kV Destruction: 8 kV
Vibration resistance	Malfunction: 0.5-mm single amplitude at 10 to 55 Hz Destruction: 0.75-mm single amplitude at 10 to 55 Hz
Shock resistance	Malfunction: 200 m/s ² , 3 times each in 6 directions Destruction: 300 m/s ² , 3 times each in 6 directions
EMC	(EMI) Emission Enclosure: EN61812-1 Emission AC Mains: EN55011 Group 1 class B Harmonic Current: EN61000-3-2 Voltage Fluctuation and Flickering: EN61000-3-3 (EMS) Immunity ESD: EN61812-1 EN61000-4-2: 6 kV contact discharge (level 3) 8 kV air discharge (level 3) Immunity RF-interference from AM Radio Waves: EN61000-4-3: 10 V/m (80 MHz to 1 GHz) (level 3) Immunity Burst: EN61000-4-4: 2 kV power port and output port (level 3) 1 kV control port with capacitive clamp (level 3) Immunity Surge: EN61000-4-5: 2 kV common mode (level 3) 1 kV differential mode (level 3)
Case color	Light gray (5Y7/1)
Degree of protection	IP30 (IP20 for terminal block)
Weight	Approx. 70 g

Connections

■ Block Diagram

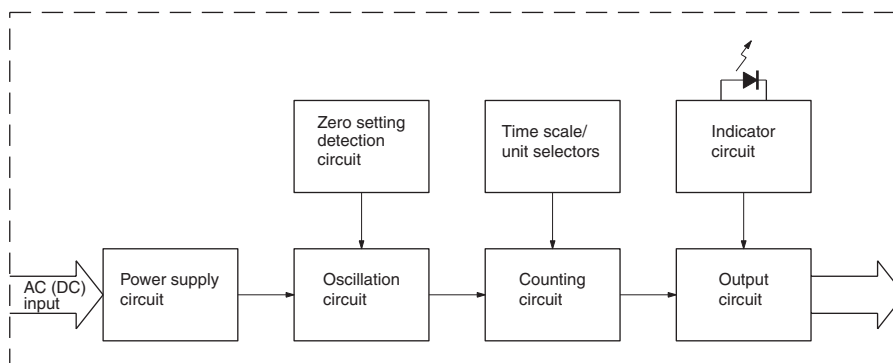

■ I/O Functions

Inputs	---	
Outputs	Control output	Outputs are turned ON when the preset value is reached.

Terminal Arrangement

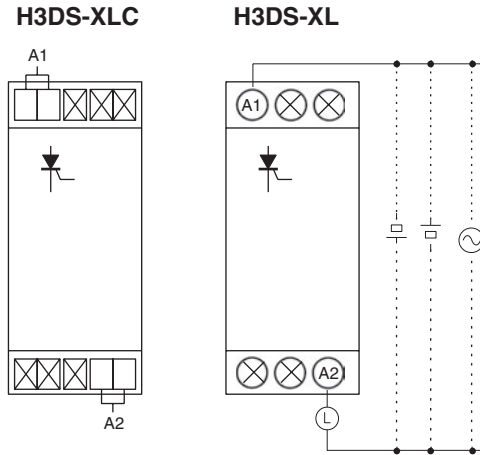

Note: DC supply voltage does not require the designation of polarity.

Operation

Basic Operation

Setting of Selector

The selectors can be turned clockwise and counterclockwise to select the desired time scale, or operating mode.

Each selector has a snap mechanism that secures the selector at a given position. Set the selector at a position at which it is secured. Do not set it midway between two securing positions or a malfunction could result from improper setting.

Selection of Time Scale

The time scale is selected by turning the time scale selector. The time scales will appear in the following order in the time scale display window on the left of the selector:

1 s, 0.1 s, 1 h, 0.1 h, 10 h, 1 h, 1 m, 0.1 m.

Note: The time scale “1h” appears twice. Both instances indicate exactly the same time scale.

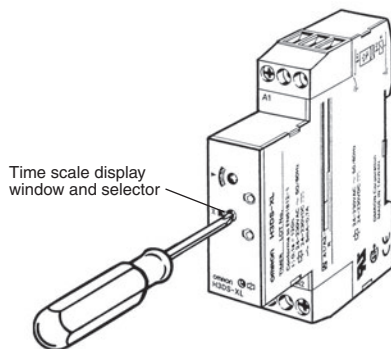

Locking/Unlocking of Selectors and Time Setting Dial

The time setting dial and time scale selector can be locked using the Y92S-38 Lock Key, a special pen type tool that is sold separately. To lock the dial or selectors, insert the Lock Key in the keyhole to the lower right of the dial or selector and turn it clockwise until the dial or selector is completely covered with the red cover. To unlock, turn the Lock Key in the opposite direction.

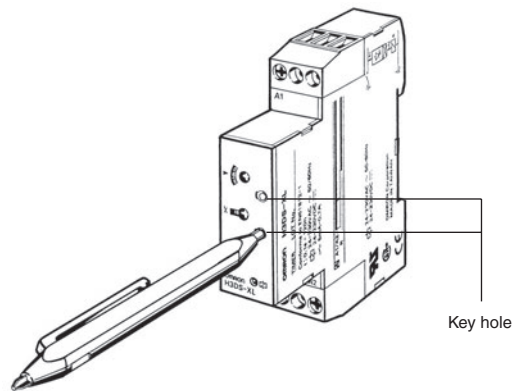

■ Timing Charts

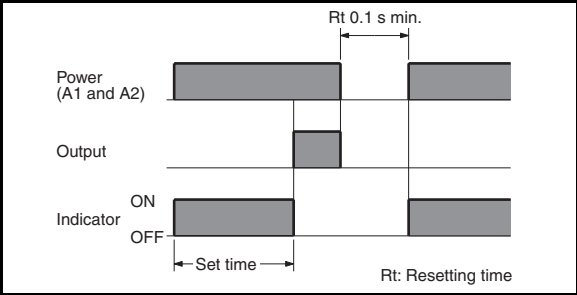

Nomenclature

H3DS-XL□

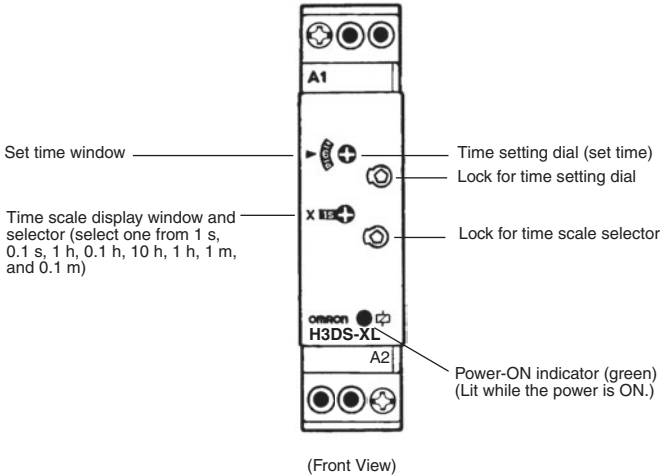

(Front View)

H3DS-XLC

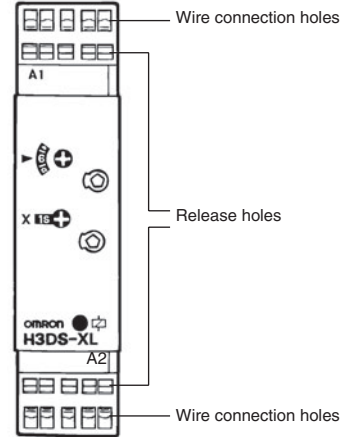

(Front View)

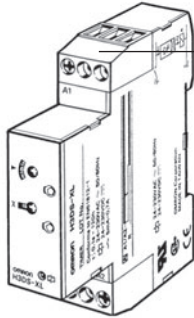

Attach the enclosed label here as a nameplate. (The label is attached to the Timer's DIN Track hook section at the time of shipment.)

Dimensions

H3DS-XL

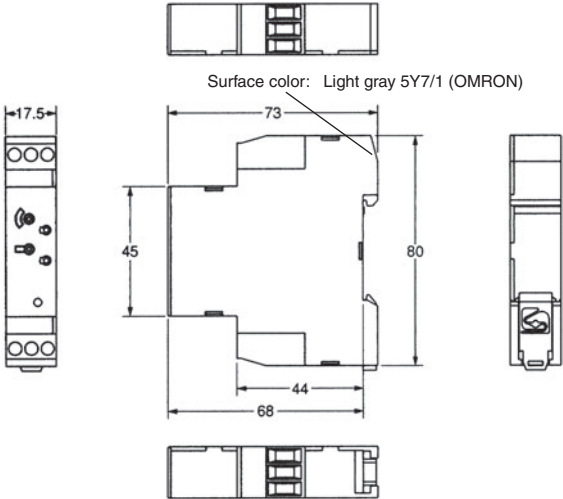
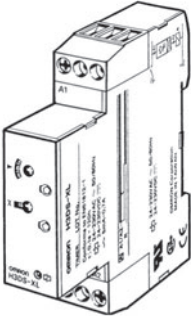

H3DS-XLC

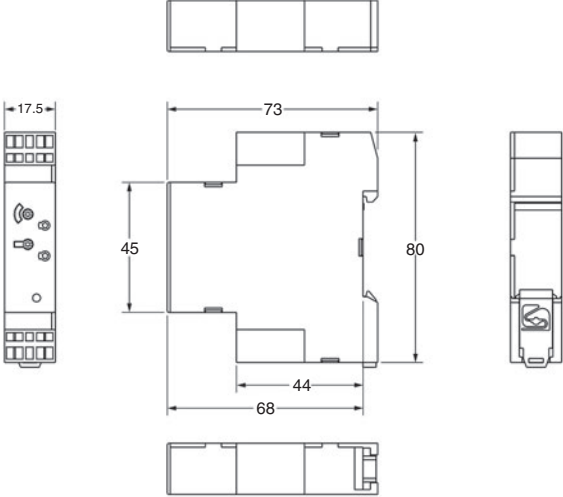
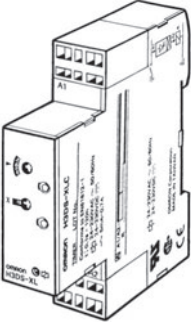

ALL DIMENSIONS SHOWN ARE IN MILLIMETERS.
 To convert millimeters into inches, multiply by 0.03937. To convert grams into ounces, multiply by 0.03527.

In the interest of product improvement, specifications are subject to change without notice.

Installation of Screw-Less Clamp Models

■ Tools

A flat-blade screwdriver should be used to mount the cables.

Applicable Screwdriver

- Flat-blade, Parallel-tip, 2.5 mm diameter

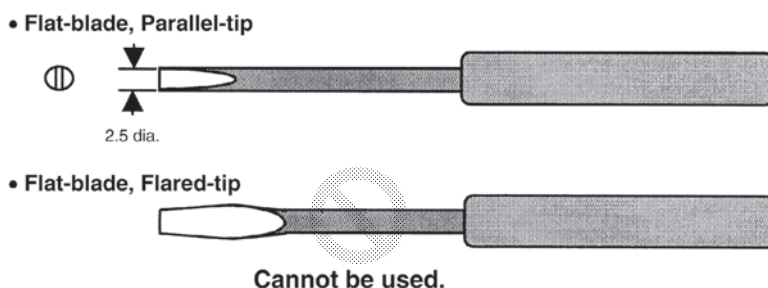

Examples: FACOM AEF.2.5 × 75E
VESSEL No. 9900-(-)2.5 × 75
WAGO 210-119
WIHA 260/2.5 × 40

■ Applicable Wires

Applicable Wire Sizes

0.2 to 1.5 mm², AWG24 to AWG16

Applicable Wire Type

Solid wires, stranded wires, flexible wires, or wires with ferules can be used.

(See note 1) $1.8 \leq \text{Diameter } D \text{ (mm)} \leq 3.0$ (see note 2)

Conductor diameter d (mm) or length of sides a and b (mm) ≤ 1.6

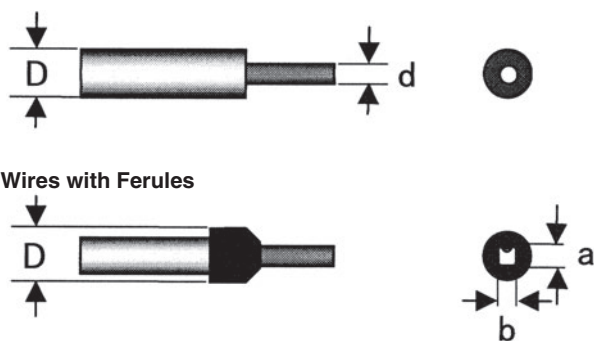

Note: 1. If the overall diameter of the wire is less than 1.8 mm, do not insert the wire past the conductor. Refer to the following diagrams.



2. If the overall diameter of the wire is over 2.8 mm, it will be difficult to use double wiring.

■ Wiring

Use wires of the applicable sizes specified above. The length of the exposed conductor should be 6 to 7 mm.

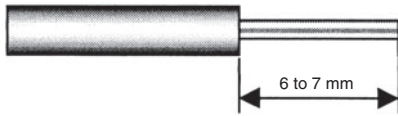

Fig. 1 Exposed Conductor Length

Use the following wiring procedure.

1. Insert the specified screwdriver into the release hole located beside the wire connection hole where the wire is to be inserted.

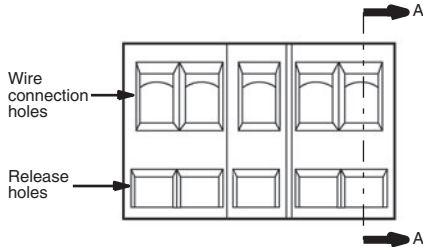

Fig. 2 Wire Connection Holes and Release Holes

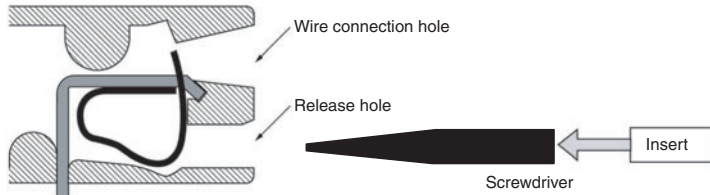
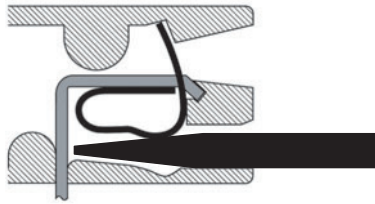

Fig. 3 Section A-A of Fig. 2



2. Insert the exposed conductor into the wire connection hole.



3. Pull out the screwdriver.

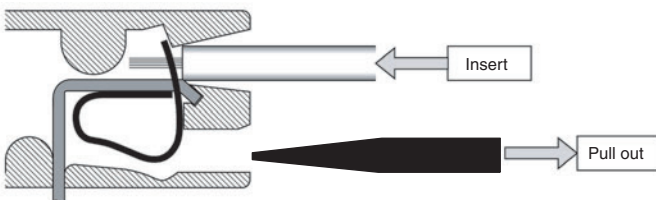

■ Precautions

Always insert the screwdriver straight into the hole, never at an angle. The clamp spring may be deformed if the screwdriver is not straight.

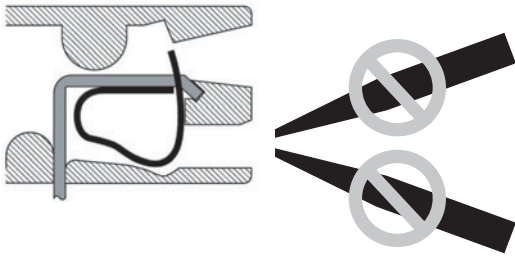

Do not move the screwdriver side to side in the clamp hole. The clamp spring may be deformed if the screwdriver is moved sideways.

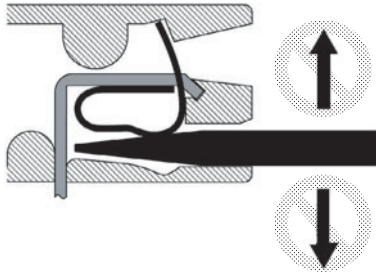

Accessories (Order Separately)

Note: All units are in millimeters unless otherwise indicated.

■ Dimensions

Lock Key
Y92S-38

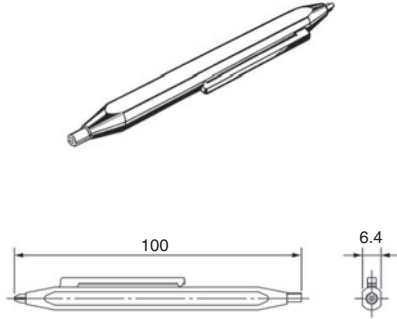

Mounting Track
PFP-100N, PFP-50N

PFP-100N2

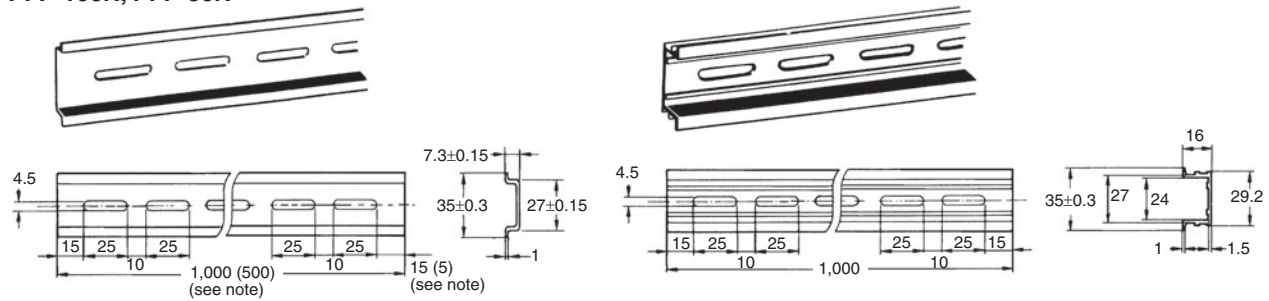

Note: The values shown in parentheses are for the PFP-50N.

End Plate
PFP-M

Spacer
PFP-S

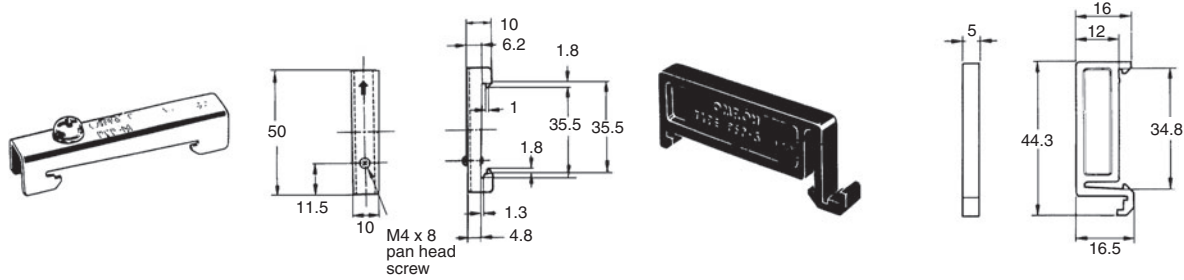

Safety Precautions

Changing of Setting

CAUTION

Do not change the time scale or operating mode, while the Timer is in operation or malfunction could result.

Power Supplies

The H3DS Series is provided with a transformerless power supply system. An electric shock may be received if the input terminal is touched while power is being supplied.

Use the bar terminal for wiring the H3DS. Using a stranded-wire terminal may cause a short-circuit due to a stray wire entering into the Timer.

Both AC and DC power supplies can be connected to the power input terminals without regarding polarity.

With the H3DS only, a DC power supply must be connected to the power input terminals as designated according to the polarity of the terminals.

A DC power supply can be connected if its ripple factor is 20% or less and the mean voltage is within the rated operating voltage range of the Timer.

Make sure that the voltage is applied within the specified range, otherwise the internal elements of the Timer may be damaged.

Connect the power supply voltage through a relay or switch in such a way that the voltage reaches a fixed value at once or the Timer may not be reset or a timer error could result.

Be sure that the capacity of the power supply is large enough, otherwise the Timer may not start due to inrush current (approx. 3 A) that may flow for an instant when the Timer is turned on.

For the power supply of an input device of the H3DS-ML□, use an isolating transformer, of which the primary and secondary windings are mutually isolated and the secondary winding is not grounded.

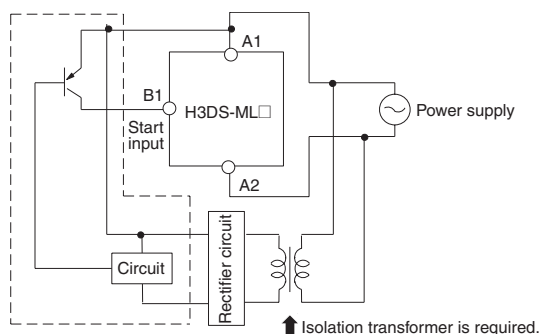

Installation

If the load current is continuously being supplied to the Timer for a long period of time, be sure to provide the mounting clearance as shown in the figure below. If used under the conditions other than those specified below (except for the H3DS-XL□), the life of internal components may be shortened due to an excessive rise in the internal temperature.

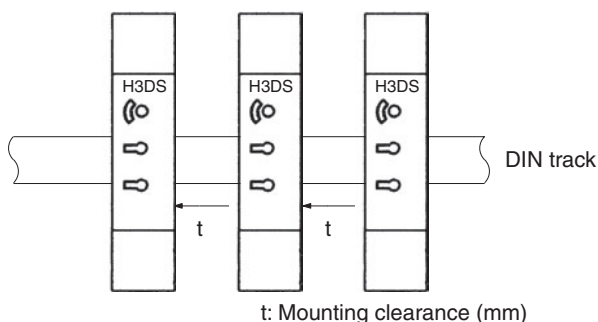

Switching Current vs. Ambient Temperature (When Mounting Two or More H3DS Units Side-by-Side)

• H3DS-ML□/-SL□/-AL□

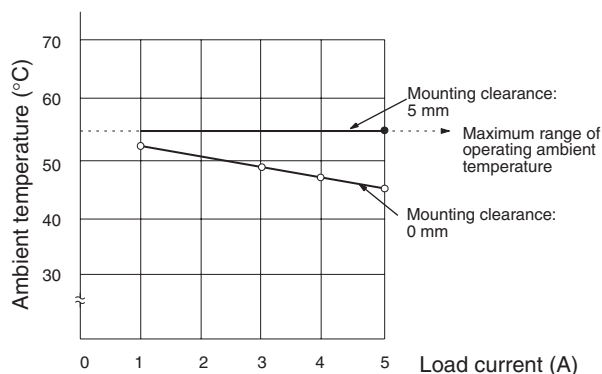

• H3DS-FL□/-GL□

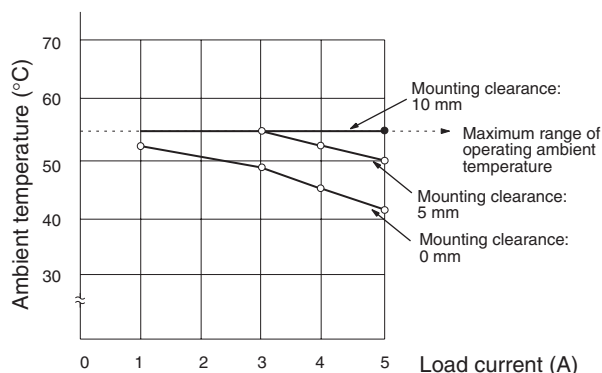

Input/Output

Relationship between Input and Power Supply Circuits (H3DS-ML□)

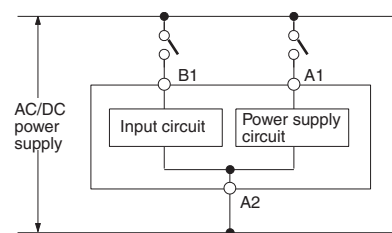

Since the input circuit and the power supply circuit are configured independently, the input circuit can be turned on or off irrespective of the on/off state of the power supply. It must be noted that a voltage equivalent to the power supply voltage is applied to the input circuit.

When connecting a relay or a transistor as an external signal input device, pay attention to the following points to prevent short-circuiting due to a sneak current to the transformerless power supply.

If a relay or transistor is connected to two or more Timers, the input terminals of those Timers must be wired properly so that they will not be different in phase or the terminals will be short-circuited to one another (refer to the figures below).

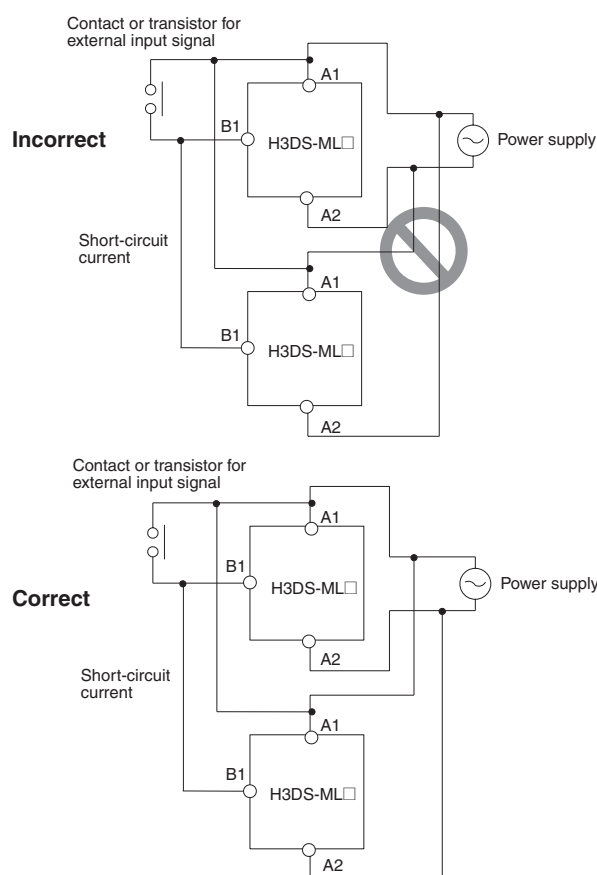

The H3DS Series is provided with a transformerless power supply system.

Input Wires

The input wires must be as short as possible. If the floating capacity of wires exceeds 2,000 pF (approx. 17 m for cables with 120 pF/m), the operation will be affected. Pay particular attention when using shielded cables.

Precautions for EN61812-1 Conformance

The H3DS as a built-in timer conforms to EN61812-1 provided that the following conditions are satisfied:

The output section of the H3DS is provided only with basic isolation. To ensure reinforced isolation required by the EN61812-1, provide supplementary basic isolation on the load side connected to the output.

The H3DS itself is designed according to the following:

- Overvoltage category III
- Pollution degree 2

On the above basis:

Operation parts on the front and bottom: Reinforced isolation

– With clearance of 5.5 mm and creepage distance of 5.5 mm at 230 VAC

Output: Basic isolation

– With clearance of 3 mm and creepage distance of 3 mm at 230 VAC

Environment

When using the Timer in an area with excess electronic noise, separate the Timer, wiring, and the equipment which generates the input signals as far as possible from the noise sources. It is also recommended to shield the input signal wiring to prevent electronic interference.

Organic solvents (such as paint thinner), as well as very acidic or basic solutions can damage the outer casing of the Timer.

Do not use the Timer in places where it is exposed to dust, corrosive gas, or direct sunlight.

When storing the Timer, make sure that the ambient temperature and humidity are within the rated values. Leave the Timer at room temperature for at least three hours before using the Timer if it has been stored at an ambient temperature of -10°C or below.

Leaving the Timer with outputs ON at a high temperature for a long time may hasten the degradation of internal parts (such as electrolytic capacitors). Therefore, use the product in combination with relays and avoid leaving the product as long as more than 1 month with the output turned ON.

Others

If the Timer is mounted on a control board, dismantle the Timer from the control board or short-circuit the circuitry of the power board before carrying out a voltage withstand test between the electric circuitry and non current-carrying metal part of the Timer, in order to prevent the internal circuitry of the Timer from damage.

勝特力電材超市-龍山店 886-3-5773766
 勝特力電材超市-光復店 886-3-5729570
 勝特力電子(上海) 86-21-34970699
 勝特力電子(深圳) 86-755-83298787
<http://www.100y.com.tw>

ALL DIMENSIONS SHOWN ARE IN MILLIMETERS.

To convert millimeters into inches, multiply by 0.03937. To convert grams into ounces, multiply by 0.03527.

In the interest of product improvement, specifications are subject to change without notice.