

勝特力材料 886-3-5753170
 勝特力电子(上海) 86-21-34970699
 勝特力电子(深圳) 86-755-83298787
 Http://www.100y.com.tw

Series W1H, W13

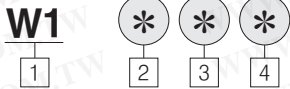

How to Order



- ① TPC Auto Switch Model
- ② 3 : Reed 2 wire AUTO S/W
H : Solid State 3 wire AUTO S/W
- ③ N : 3 wire (NPN)
P : 3 wire (PNP)
- ④ Blank : LEAD WIRE (0.5m)
M : LEAD WIRE (1m)
L : LEAD WIRE (3m)

Internal Circuit

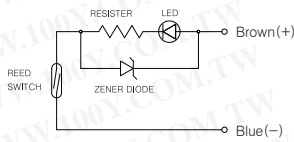

2 wire reed circuit

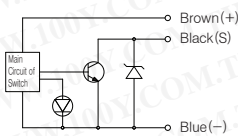

3 wire NPN solid state circuit

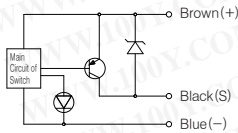

3 wire PNP solid state circuit

Caution

Please read and understand the instructions before use. Refer to the auto switch precautions before using auto switches.

Specifications

Part No.	W13	W1HN(P)
Contact wiring	Reed Wire 2 wire	Solid State 3 wire
Application	Relay, Sequence Control	
Voltage	DC24V	AC100V DC24V
Load Current	5~40mA	≤40mA
Contact Protection Circuit	None	Built-in
Internal Voltage Drop	≤ 2.4V	≤ 1.5V
Indicator Lamp	ON : When Red LED	
Output	-	NPN(PNP)
Current Consumption	-	≤5mA
Current Leakage	None	≤100μA
Operation Time	≤1ms	≤2ms
Lead Wire	Oil Resistant Vinyl Code	
Shock Resistance	30G 100G	
Insulation Resistance	100MΩ or more (500DVC Mega) between lead wire and case	
Voltage Resistance	For 1 min. (in AC1500V/between a lead wire case)	
Temperature	-10 ~ 60°C	
Protection Structure	IEC Standard IP67, Water Proof, and (JISCO920), Oil Structure	

Protection Structure

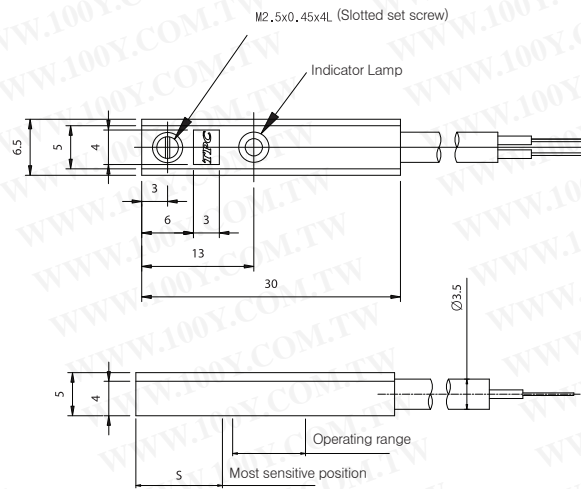

Operating Range

Section	W13	W1HN(P)
Most sensitive position (S)	10mm	1 ~ 2mm
Operation range (L)	6 ~ 12mm	4 ~ 10mm

Series W2P

SPSA

SPSB

Auto Switch

SPS

Intense-Magnetism Resistant Auto Switch

W2P□/Solid State Type Auto Switch(Grommet Type)



How to Order

W2P

1



2

1 TPC Auto Switch Model

2 L : LEAD WIRE(3m)
Z : LEAD WIRE(5m)

Specifications

Part No.	W2P(L), (Z)
Application	Relay, Sequence Control
Load Voltage	DC24V 0±15%
Load Current	2 ~ 40mA
Contact	Without contact
Wiring	2 wire nonpolar type
Internal Voltage Drop	≤5V 1.0mA
Current Leakage	0.6mA
Indicator Lamp	RED/GREEN/RED (ON)
Operation Time	≤40ms
Lead Wire	Oil Resistant Vinyl Code
Shock Resistance	30G
Insulation Resistance	100MΩ or more (500DVC Mega) between lead wire and case
Voltage Resistance	For 1 min. (in AC1500V/between a lead wire case)
Temperature	-10 ~ 80°C
Protection Structure	IEC Standard IP67, Water Proof, and(JISC0920),Oil Structure

Internal Circuit

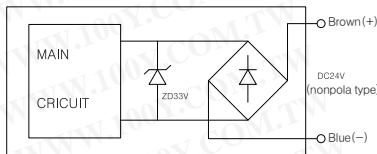

W2P circuit

Auto Switch
Operating Range

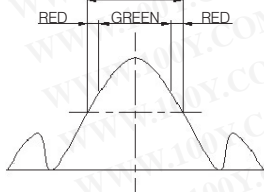

Protection Structure

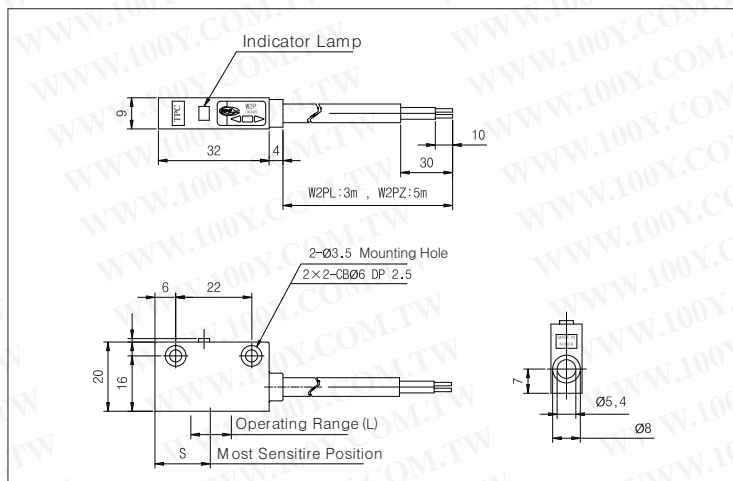

Caution

It can be used on single phase AL. However direct inverter(or rectification type) condenser type spot welder are unservice a bility.

※ Do not fix the auto switch the existing screw installed on the auto switch body. The auto switch may be damaged if a screw other than one supplied is used.

Operating Range

Section	W2P
Most sensitive position(S)	16mm
Operation range(L)	8~10mm

Reed Switch Type/Tie Rod Mounted Type/Series W3



Auto Switch Specifications

Auto Switch Model	W3		
Application	Relay, Sequence Control		
Voltage	DC24V	AC100V	AC200V
Load Current	5~50mA	5~25mA	5~12.5mA
Protection Circuit Contact Breaker Point	Built-in		
Internal Voltage Drop	2.4V		
Indicator Lamp	ON:Red Light Emitting Diode		

- Current Leakage - None
 - Response time - 1.2ms
 - Lead Wire - Oil proof vinyl. $\phi 4(0.3)\text{mm}^2$, 2 wire(red, black), 0.5m
 - Impact Resistance - 30G
 - Insulation Resistance - $100\text{M}\Omega$ or more under the test voltage 500VDC (Between case and cable)
 - Withstand Voltage - 1500VAC 1min(between case and cable)
 - Ambient Temperature - $5\sim 60^\circ\text{C}$
 - Protective Construction - IEC spec IP67, Water-proof(JISCO920), oil-proof.
- ※ If 3m lead wire is required, L is put at end of model numbers.
(Example) W3L

Auto Switch/Internal Circuit

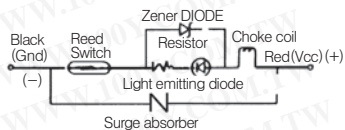

Auto Switch Dimensions

(mm)

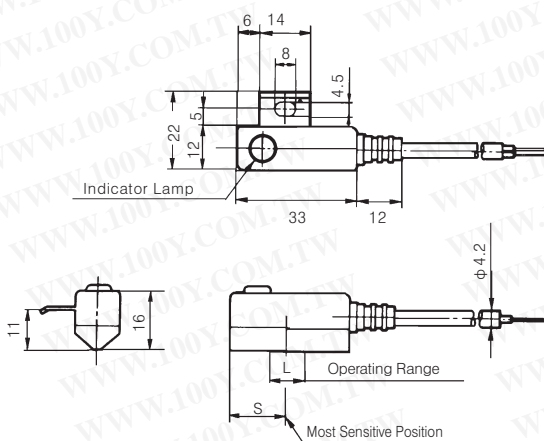

Operating Range

Section	W3
Most sensitive position(S)	8.5mm
Operation range(L)	9~11mm

Reed Switch Type/Tie Rod Mounted Type/Series W4



Auto Switch Specifications

Auto Switch Model	W4	
Application	Relay, Sequence Control	
Voltage	DC24V	AC100V
Load Current	5~40mA	5~20mA
Protection Circuit for Contact Breaker Point	None	
Internal Voltage Drop	2.4V or less	
Indicator Lamp	ON:Red light emitting diode	

- Current Leakage - None
 - Response time - 1.2 ms
 - Lead Wire - Oil proof vinyl. ϕ 3.4, 0.2mm², 2 wire(red, black), 0.5 m
 - Impact Resistance - 30G
 - Insulation Resistance - 50M Ω or more under the test voltage 500VDC (Between case and cable)
 - Withstand Voltage - 1500VAC 1min (between case and cable)
 - Ambient Temperature - 5~60 $^{\circ}$ C
 - Protective Construction - IEC spec IP67, Water-proof(JISCO920), oil-proof.
- ※ If 3m lead wire is required, L is put at end of model numbers.
(Example) W4L

Auto Switch/Internal Circuit

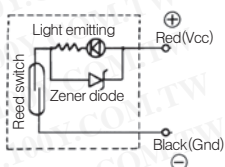

Auto Switch Dimensions (mm)

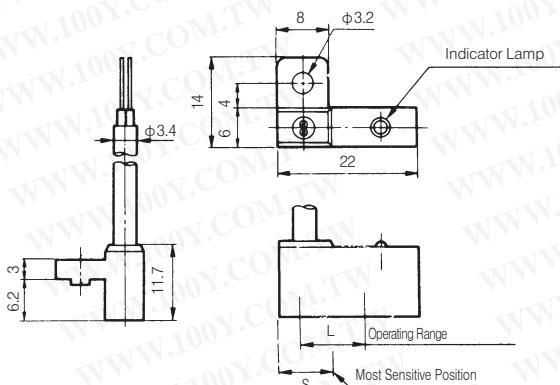

Operating Range

Section	W4
Most sensitive position(S)	8.5mm
Operation range(L)	6~12mm

SPSA

SPSB

Auto Switch

SPS

Reed Switch Type/Band Mounted Type/Series W5



Specifications W5 Type(With indicator lamp)

Auto Switch Model	W5	
Application	Relay, Sequence Control	
Voltage	DC24V	AC100V
Load Current	5~40mA	5~20mA
Protection Circuit for Contact Breaker Point	None	
Internal Voltage Drop	2.4V or less	
Indicator Lamp	ON:Red light emitting diode	

- Current Leakage – None
 - Response Time – 1.2ms
 - Lead Wire – Oil proof vinyl, ϕ 3.4 0.2mm, 2 Wire(red, black), 0.5m(18in)
 - Impact Resistance – 30G
 - Insulation Resistance – 50M Ω or more under the test voltage 500VDC (Between case and cable)
 - Withstand Voltage – 1500VAC 1min (between case and cable)
 - Ambient Temperature – -10~60°C
 - Protective Construction – IEC spec IP67, Water-proof (JISCO920), oil-proof.
- ※ If 3m lead wire is required, L is put at the end of numbers.
Example : W5L

Auto Switch/Internal Circuit

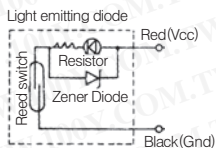

Auto Switch Dimensions (mm)

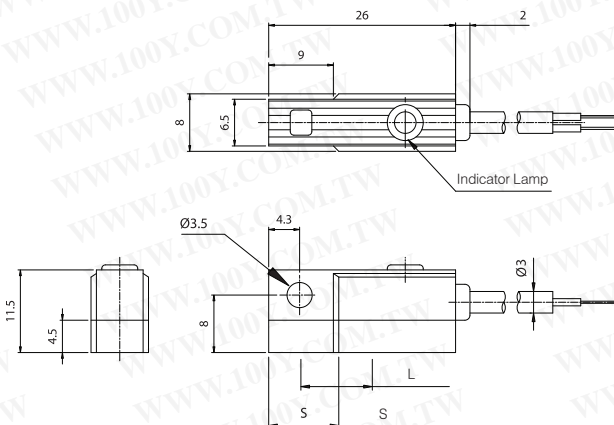

Operating Range

Section	W5
Most sensitive position(S)	9.5mm
Operation range(L)	6~8mm

Automatic Reed Switch/Intense-Magnetism-Resistant Type/Series W6/W7

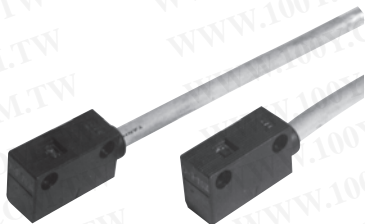

Auto Switch Specifications

Auto Switch model	W6(L)(Z)	W7(L)(Z)	
Voltage	AC120V	DC24V	AC100V
Load Current	20mA	5~40mA	5~20mA
Internal Voltage Drop	0V	Max 2.4V	
Operating Time	1.2m/sec		
Impact Resistance	30G		
Protective Construction	IEC Standard IP67		
Pilot Lamp	OFF Lighting (Red LED)	ON Lighting (Red LED)	
Current Leakage	MAX. 1.8mA	0	
Ambient Temperature Range	5~60°C		
Insulation Resistance	50M Ω /500V DC		
Application	Relay, Sequence Controller		

SPSA

SPSB

Auto Switch

SPS

Internal Circuit

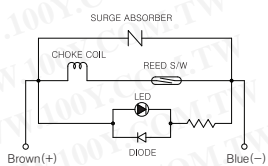

W6 Circuit

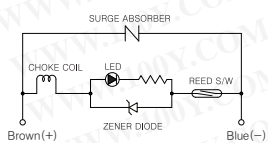

W7 Circuit

Dimension

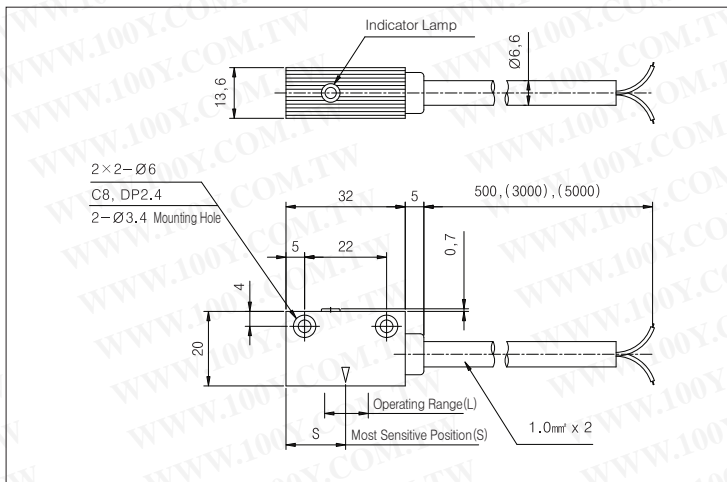

Caution

Please read and understand the instructions before use. Refer to the auto switch precautions before using auto switches.

Operating Range

Section	D-P70R	D-P74R
Most sensitive position(S)	16mm	16mm
Operation range(L)	8 ~ 9mm	8 ~ 9mm

Mini Auto Switch



- ENLARGEMENT OF STANDARD LEAD WIRE
- OIL PROOF AND INTERNAL COMBUSTION IS EXCELLENT
- COMPACT DESIGN
- EASY TO CHECK EXISTING / NON PLUG

How to Order

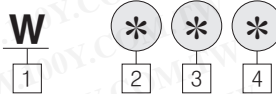

1 TPC Auto Switch Model

2 7 : TPC Auto Switch Model

- 8 : Mini existing plug point AUTO SWITCH
- 9 : Mini non plug point round AUTO SWITCH
- 10 : Mini non plug point round AUTO SWITCH(10mm)

3 H : LEAD WIRE HORIZONTAL TYPE

(W7 : Horizontal only)

V : LEAD WIRE VERTICAL TYPE

(W10 : Vertical only)

4 Blank : Wiring Method(2 wires), LEAD WIRE Length(1m)

- L : LEAD WIRE(3m)
- N : Wiring Method(3 wires, NPN), LEAD WIRE Length(1m)
- P : Wiring Method(3 wires, PNP), LEAD WIRE Length(1m)
- NL : Wiring Method(3 wires, NPN), LEAD WIRE (3m)
- PL : Wiring Method(3 wires, PNP), LEAD WIRE (3m)

*N, P, NL, PL are for non plug point round type.

(Note2) W10 : Lead wire 0.5mm, 2wires, "N" type only

(Note3) W7 : Lead 2wires, "L" type only

Specification

Item	W7	Contact (W8)	Non-Contact (W9)	W10 * *	
Size	Outer Diameter of 4mm		Outer Diameter of 4mm	Solid State Switch	Solid State Switch (NPN)
Load Voltage	AC220V	DC24V, AC100V	DC24V		
Load Current	5~15mA	5~40mA (DC24V)	5~30mA	5~40mA	Less than 100mA
		5~20mA(AC110V)		None	
Direction of Lead Wire	Vertical, Horizontal		Vertical, Horizontal	Vertical(V)	
Lamp	Red LED lights when ON		Green LED lights when ON	Green LED lights when ON	
Wiring	Double wiring		Double wiring (Triple wiring)		
Output	-		NPN, PNP		
Attachment	Screw-attachment on		Screw-attachment on Rail		
Operation Time	Less than 1.2ms		Less than 1.2ms	Less than 4.5V	Less than 1.5V
Inner Voltage Epression	Less than 2.4V		Less than 4.5V	Less than 0.9mA	Less than 100μA
Minimum Gauss Required	Higher than 65G		Higher Than 35G	-	Less than 12mA
Maximum Gauss Limited	Lower than 450G				
Lifespan of Switch	1×10 ⁷ when loaded 5V, 5mV		-		
	1×10 ⁷ when loaded 12V, 5mV				
	1×10 ⁷ when loaded 24V, 5mV				
Electric Current Leakage	-		Less than 15mA under DC24V		

Remote Range of the Switch

Classification	W7 * *, W8 * *	W9 * *	W10 * *
L(Maximum Remote Range)	13	6.5	7
Remote Range of the Switch	7~12	4.3~4.7	4~7

* Warning : When the amount of motion electric current loaded on the controllers such as PLC, is lower than that of current leakage, it is called non-operative state (ON) and results in miss-operation.
When the number of parallel connection is n, the amount of current leakage multiplies n times.

Mini Auto Switch

Dimension

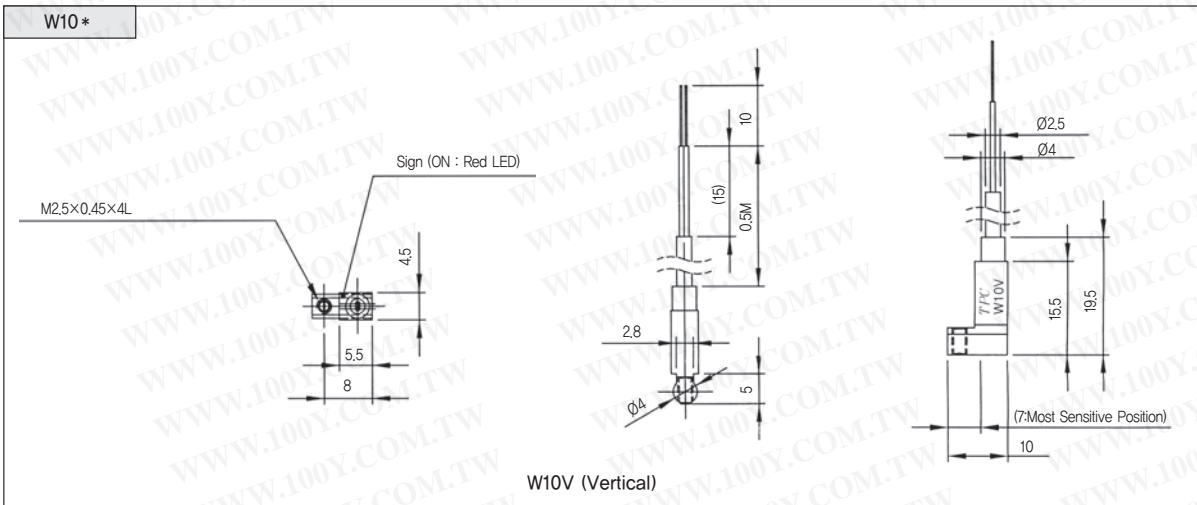
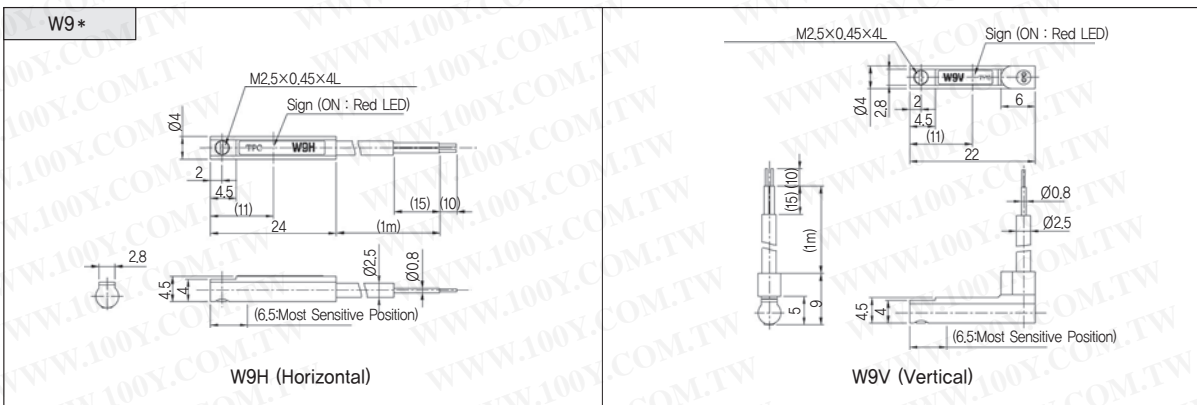
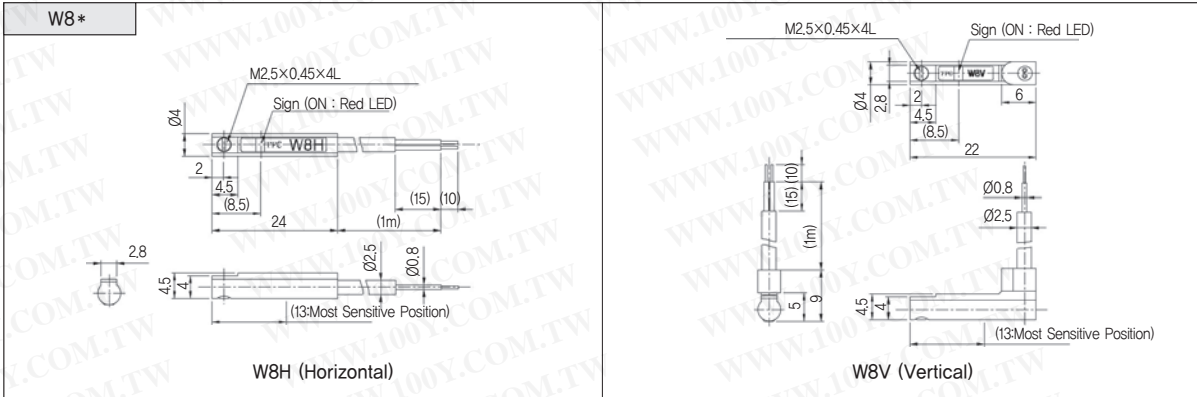

SPSA

SPSB

Auto Switch

SPS

勝特力材料 886-3-5753170
 勝特力电子(上海) 86-21-34970699
 勝特力电子(深圳) 86-755-83298787
[Http://www.100y.com.tw](http://www.100y.com.tw)