



SHIHLIN ELECTRIC  
士林電機

勝特力電材超市-龍山店 886-3-5773766  
勝特力電材超市-光復店 886-3-5729570  
勝特力电子(上海) 86-21-34970699  
勝特力电子(深圳) 86-755-83298787  
<http://www.100y.com.tw>

2021.10 版

# 電動機保護斷路器 MANUAL MOTOR STARTER



工廠驗證



# BREAKER & SWITCHGEAR SYSTEM

用途

- ◆適用於交流690V以下，頻率為50Hz或60Hz，額定工作電流為0.1~65A的電路中，作為三相電動機的過載、欠相、短路保護及不頻繁的起動控制和運轉中分斷之用，還可作隔離器使用。

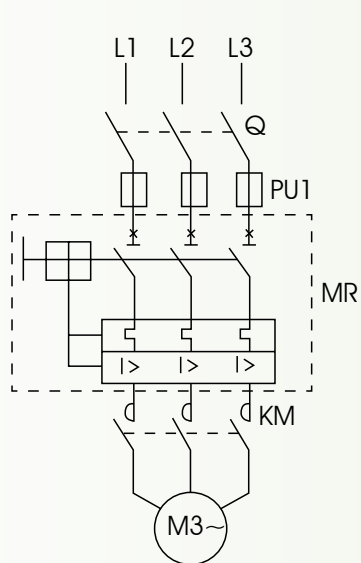

產品特點



- ◆符合標準：IEC60947-2、IEC60947-4-1、UL508、TUV
- ◆接線工作量減少50%：無熔線斷路器+接觸器+熱過載繼電器(100%) → 電動機保護斷路器+接觸器(50%)
- ◆結構緊湊，安裝空間減少57%：無熔線斷路器+熱過載繼電器(100%) → 電動機保護斷路器(43%)
- ◆環保設計：可回收熱塑性塑膠外殼、無鎘接點
- ◆安全性：安全保護等級IP20

## 產品型號及含義

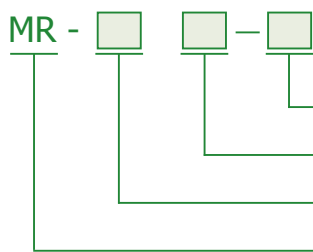

額定工作電流：0.16~32A(32AF)，13~65(65AF)  
 系列號：S-按鈕式(32AF)、R-旋轉式(32/65AF)  
 框架等級：32，65  
 電動機保護斷路器

## 正常工作條件及安裝條件

- ◆ 允許操作環境溫度：-25 ~ 55°C
- ◆ 允許儲存環境溫度：-50 ~ 80°C
- ◆ 海拔高度：安裝地點海拔高度不能超過2000m
- ◆ 污染等級：抗污染等級為3，可在IEC60947標準中定義三級污染環境中運行
- ◆ 安裝條件：(1). 安裝面與垂直面傾斜角不能超過30°  
 (2). 採用標準導軌安裝  
 (3). 應安裝和使用在無明顯晃動、沖擊及震盪的地方

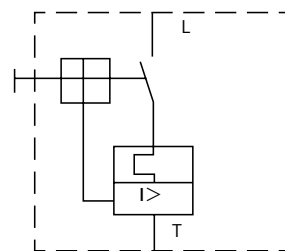

## 主要技術參數

AC-3類 三相電動機 額定功率	額定工作 電流	過載脫扣 設定範圍	磁脫扣電流	產品型號	
				按鈕式	旋轉式
400V (kW)	$I_n$ (A)	$I_n$ (A)	$I_d \pm 20\%$ (A)		
—	0.16	0.1-0.16	1.92	MR-32S-0.16	MR-32R-0.16
—	0.25	0.16-0.25	3	MR-32S-0.25	MR-32R-0.25
—	0.4	0.25-0.4	4.8	MR-32S-0.4	MR-32R-0.4
—	0.63	0.4-0.63	7.56	MR-32S-0.63	MR-32R-0.63
—	1	0.63-1	12	MR-32S-1	MR-32R-1
0.37	1.6	1-1.6	19.2	MR-32S-1.6	MR-32R-1.6
0.75	2.5	1.6-2.5	30	MR-32S-2.5	MR-32R-2.5
1.5	4	2.5-4	48	MR-32S-4	MR-32R-4
2.2	6.3	4-6.3	75.6	MR-32S-6.3	MR-32R-6.3
4	10	6-10	120	MR-32S-10	MR-32R-10
5.5	14	9-14	168	MR-32S-14	MR-32R-14
7.5	18	13-18	216	MR-32S-18	MR-32R-18
11	23	17-23	276	MR-32S-23	MR-32R-23
11	25	20-25	300	MR-32S-25	MR-32R-25
15	32	24-32	384	MR-32S-32	MR-32R-32

AC-3類 三相電動機 額定功率	額定工作 電流	過載脫扣 設定範圍	磁脫扣電流	產品型號
				旋轉式
400V (kW)	$I_n$ (A)	$I_n$ (A)	$I_d \pm 20\%$ (A)	
5.5	13	9-13	182	MR-65R-13
7.5	18	12-18	252	MR-65R-18
11	25	17-25	350	MR-65R-25
15	32	23-32	448	MR-65R-32
18.5	40	30-40	560	MR-65R-40
22	50	37-50	700	MR-65R-50
30	65	48-65	910	MR-65R-65







註：本產品有過載範圍設定旋鈕，請於額定工作電流範圍內作調整，調整鈕勿旋轉超過 360 度，以免造成功能失效。

額定容量、規格一覽表

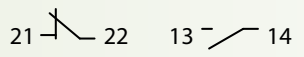
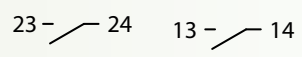
型式		MR-32S / MR-32R				
極數		3P				
額定絕緣電壓 $U_i$ (V)		690				
額定耐受衝擊電壓 $U_{imp}$ (kV)		6				
額定頻率		50/60 Hz				
額定啟斷容量 (kA) IEC 60947-2 EN 60947-2 Icu/ Ics	額定使用電流 $I_e$ (A) 額定使用電流範圍	230/240V	400/415V	440V	500V	690V
		Icu/Ics	Icu/Ics	Icu/Ics	Icu/Ics	Icu/Ics
	0.1~0.16A	100/100	100/100	100/100	80/80	80/80
	0.16~0.25A	100/100	100/100	100/100	80/80	80/80
	0.25~0.4 A	100/100	100/100	100/100	80/80	80/80
	0.4~0.63A	100/100	100/100	100/100	80/80	80/80
	0.63~1 A	100/100	100/100	100/100	80/80	80/80
	1~1.6A	100/100	100/100	100/100	80/80	80/80
	1.6~2.5A	100/100	100/100	100/100	80/80	3/2.25
	2.5~4A	100/100	100/100	100/100	80/80	3/2.25
	4~6.3A	100/100	100/100	50/50	50/50	3/2.25
	6~10A	100/100	100/100	15/15	10/10	3/2.25
	9~14A	100/100	15/7.5	8/4	6/4.5	3/2.25
	13~18A	100/100	15/7.5	8/4	6/4.5	3/2.25
17~23A	50/50	15/6	6/3	4/3	3/2.25	
20~25A	50/50	15/6	6/3	4/3	3/2.25	
24~32A	50/50	10/5	6/3	4/3	3/2.25	
溫度補償功能		自動				
欠相保護功能		●				
保護等級		IP20				
機械壽命 (次)		100,000				
電氣壽命 (次)		100,000				
允許操作環境溫度		-25 ~ 55°C				
允許儲存環境溫度		-50 ~ 80°C				

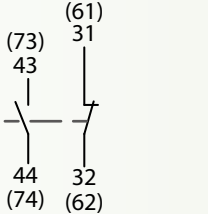
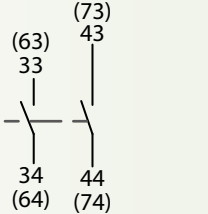
型式		MR-65R				
極數		3P				
額定絕緣電壓 $U_i$ (V)		690				
額定耐受衝擊電壓 $U_{imp}$ (kV)		6				
額定頻率		50/60 Hz				
額定啟斷容量 (kA) IEC 60947-2 EN 60947-2 Icu/ Ics	額定使用電流 $I_e$ (A) 額定使用電流範圍	230/240V	400/415V	440V	500V	690V
		Icu/Ics	Icu/Ics	Icu/Ics	Icu/Ics	Icu/Ics
	9~13A	100/100	100/100	50/50	12/6	6/3
	12~18A	100/100	100/100	50/50	12/6	6/3
	17~25A	100/100	100/100	50/50	12/6	6/3
	23~32A	100/100	100/100	50/50	12/6	6/3
	30~40A	100/100	50/50	50/50	12/6	6/3
	37~50A	100/100	50/50	50/50	12/6	6/3
48~65A	100/100	50/50	50/50	12/6	6/3	
溫度補償功能		自動				
欠相保護功能		●				
保護等級		IP20				
機械壽命 (次)		50,000				
電氣壽命 (次)		50,000				
允許操作環境溫度		-25 ~ 55°C				
允許儲存環境溫度		-50 ~ 80°C				

電動機保護斷路器附屬裝置

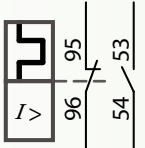
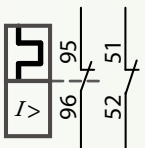
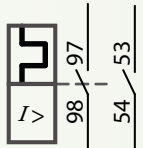
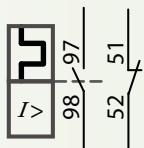
裝置名稱圖例		型名 / 接線圖				輔助接點	工作電壓	控制電壓 (Uc)
上裝 輔助接點組		MR-AE-11		MR-AE-20		1NO + 1NC 2NO	240V	
								
側裝 輔助接點組		MR-AN-11		MR-AN-20		1NO + 1NC 2NO	690V	
								
電壓 跳脫裝置		MR-AS						110V 220V 380V
欠電壓 跳脫裝置		MR-AU						110V 220V 380V
短路信號 接點組		MR-AM-11						
故障信號 接點組		MR-AD-0110	MR-AD-0101	MR-AD-1010	MR-AD-1001	1NO+1NC 2NC 2NO 1NO+1NC	240V	
								

附件齊全



應用例圖

【範例一】

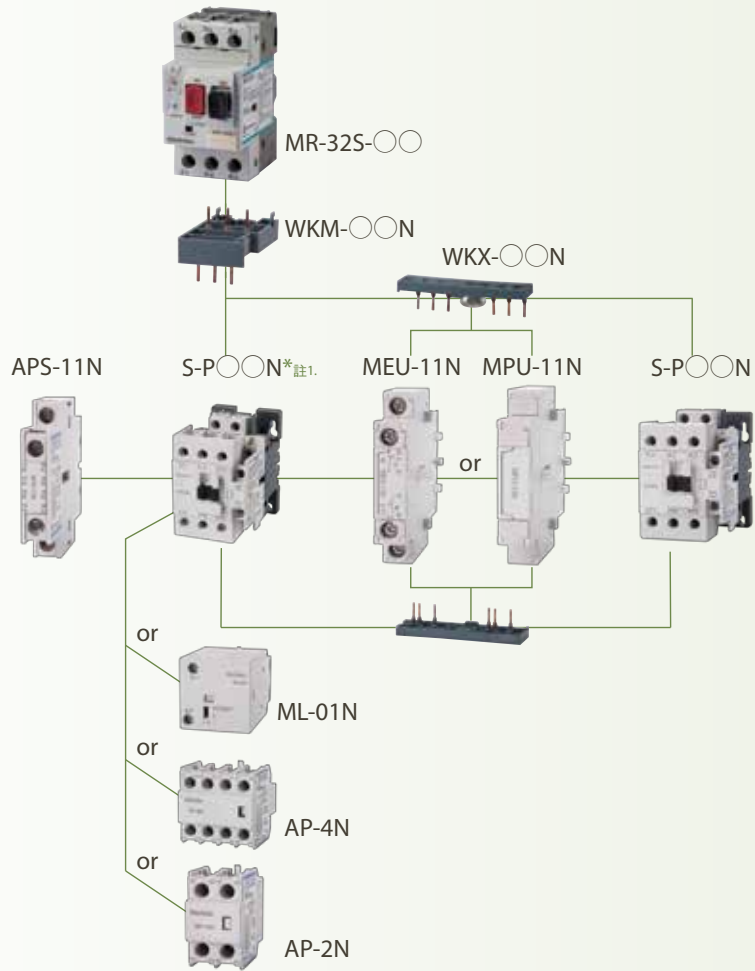



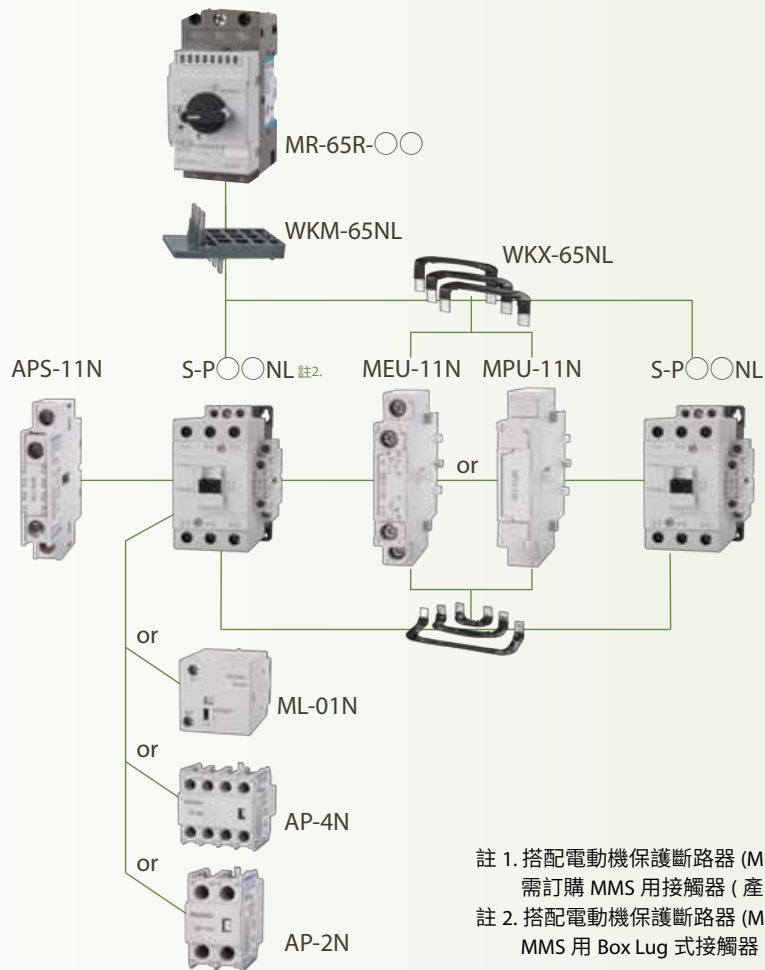



【範例二】



註 1. 搭配電動機保護斷路器 (MR-32) 時，需訂購 MMS 用接觸器 (產品線圈轉向)。

註 2. 搭配電動機保護斷路器 (MR-65) 時，MMS 用 Box Lug 式接觸器 (產品線圈轉向)。

## MMS接線模組

名稱	MMS+MC 接線模組					正逆轉接線模組		
圖示								
接線模組型號	WKM-18N	WKM-38N	WKMD-18N	WKMD-38N	WKM-65NL	WKX-18N	WKX-38N	WKX-65NL
MMS適用型號	MR-32S MR-32R				MR-65R	MR-32S MR-32R		MR-65R
接觸器適用型號	S-P9N S-P9N3 S-P9N4 S-P12N S-P12N3 S-P12N4 S-P18N S-P18N3 S-P18N4	S-P25N S-P25N3 S-P32N S-P32N3 S-P38N S-P38N3	SD-P9N SD-P12N SD-P18N	SD-P25N SD-P32N SD-P38N	S-P40NL S-P50NL S-P65NL	S-P9N S-P9N4 S-P12N S-P12N4 S-P18N S-P18N4 SD-P9N SD-P12N SD-P18N	S-P25N S-P32N S-P38N SD-P25N SD-P32N SD-P38N	S-P40NL S-P50NL S-P65NL

## 特性曲線圖

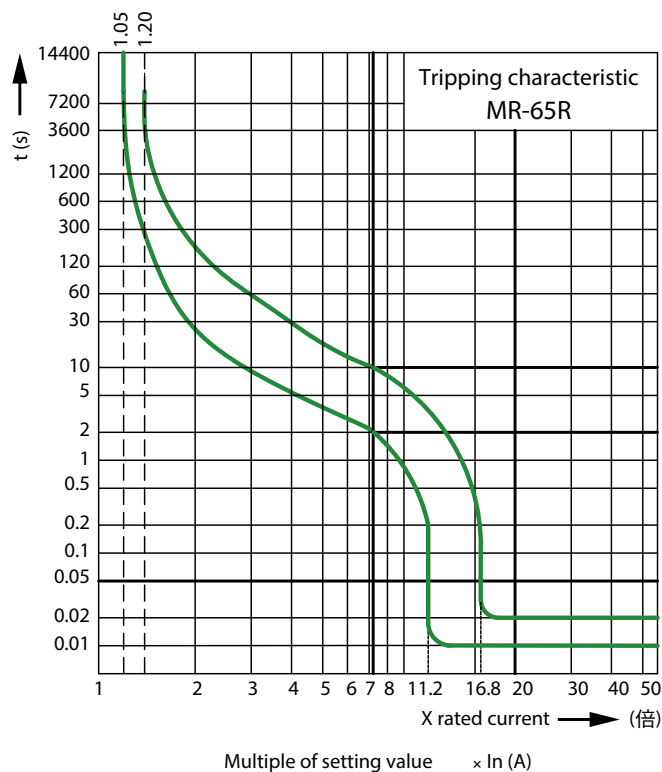
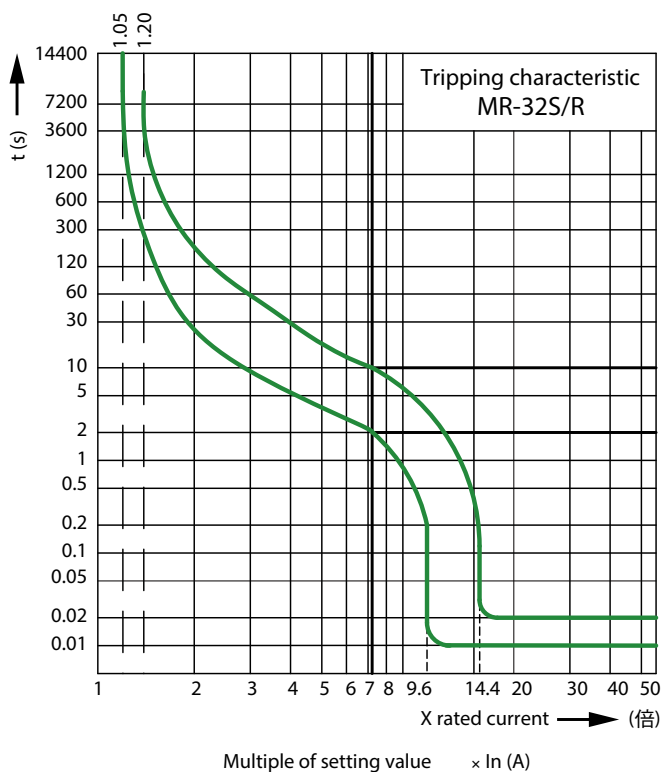

外型尺寸及安裝尺寸

電動機保護斷路器  
(按鈕式)  
MR-32S

重量：0.26kg

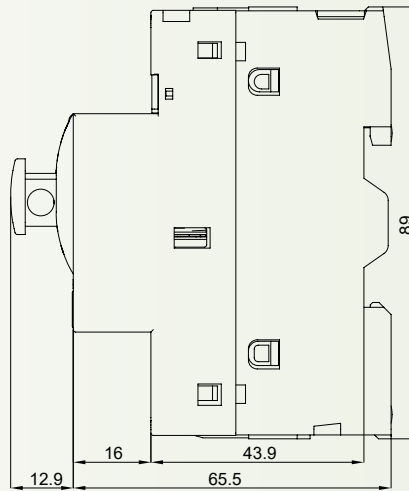
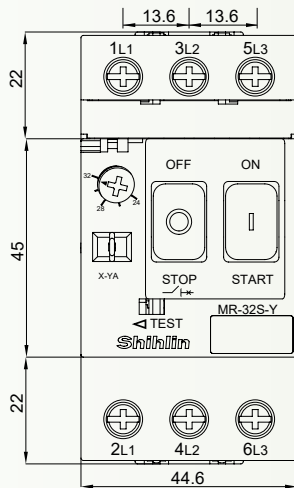

電動機保護斷路器  
(旋鈕式)  
MR-32R

重量：0.3kg

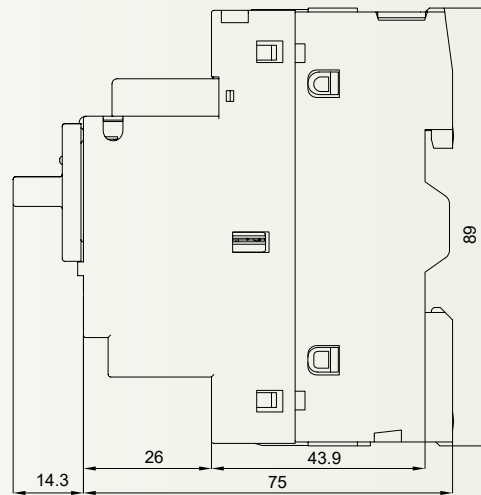
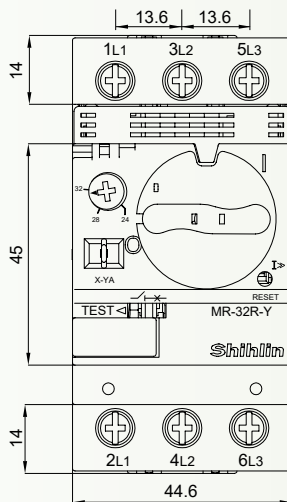

電動機保護斷路器  
(旋鈕式)  
MR-65R

重量：1kg

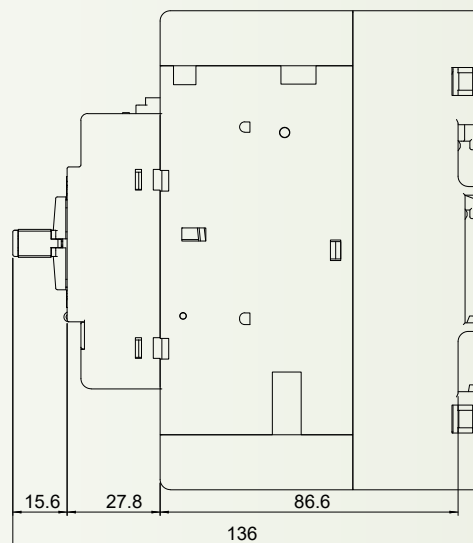
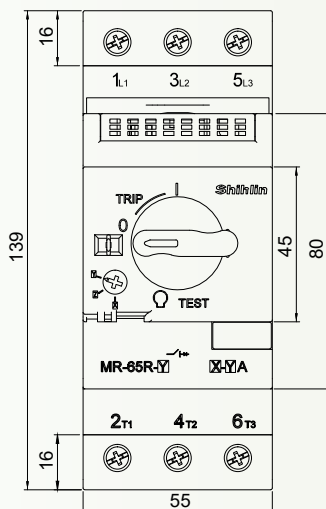

◆ 側裝輔助接點組

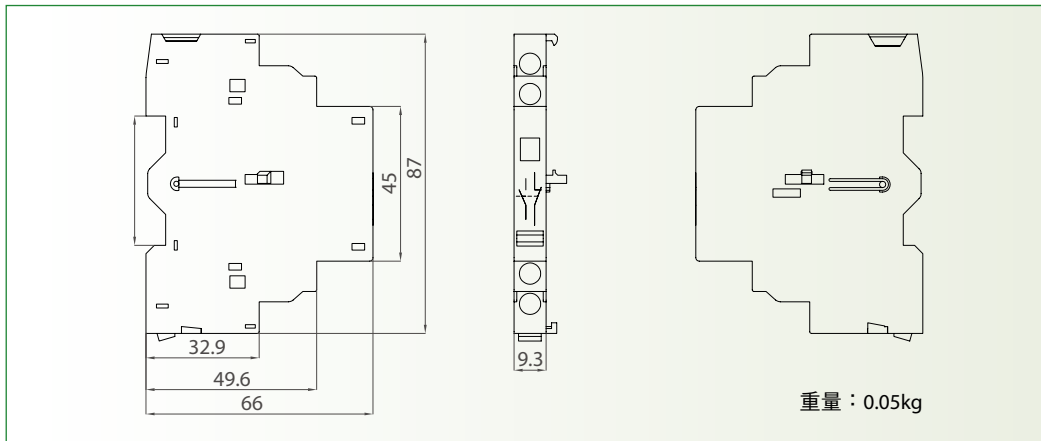

◆ 電壓/欠電壓跳脫裝置

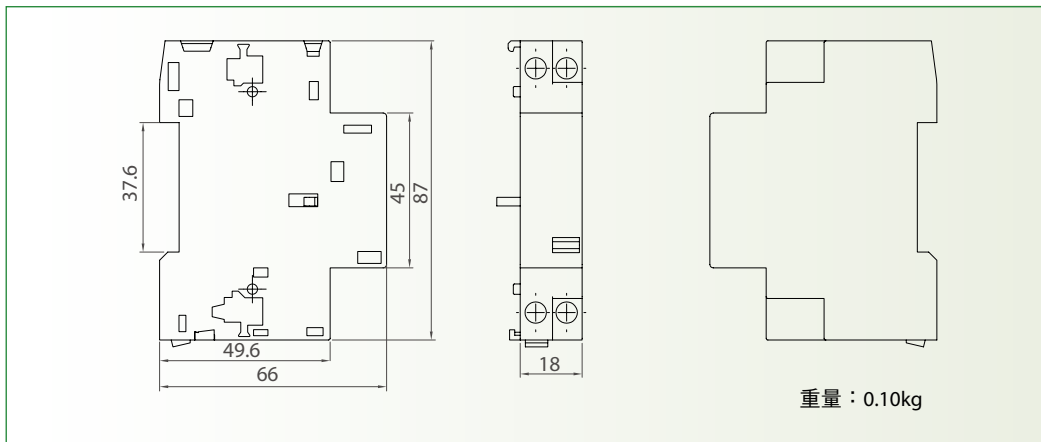

◆ 短路信號接點組

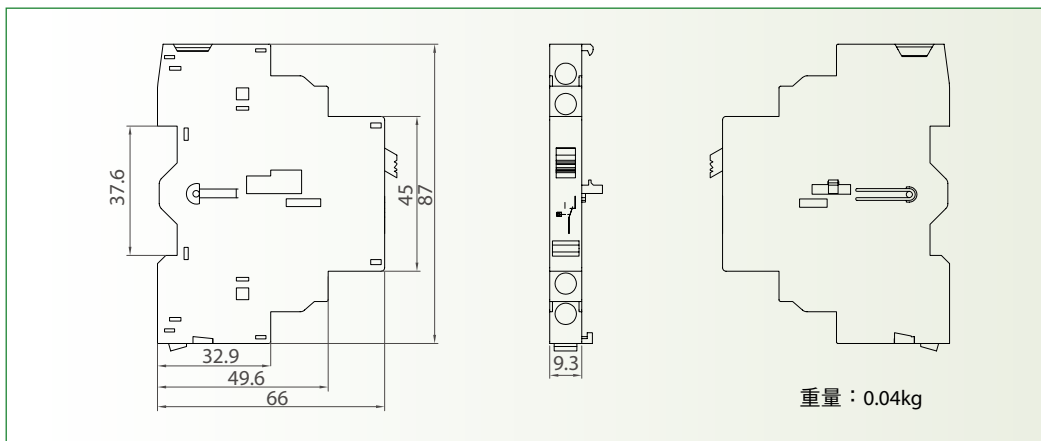

◆ 故障信號接點組

