

MECHANICAL CHARACTERISTICS $\Delta\sqrt{2}$

SUPPLY VOLTAGE	OPERATING TEMPERATURE °C	LEFT		RIGHT		DIFFERENTIAL LEFT OP TO R REL RIGHT OP TO L REL
		OPERATE	RELEASE	OPERATE	RELEASE	
4.5 TO 24.0 $\Delta\sqrt{5}$	25°C	±.006	±.006	±.006	±.006	±.010
12.0	25°C	.213±.025	.237±.025	.337±.025	.313±.025	.10 ±.01
4.5 TO 24.0 $\Delta\sqrt{5}$	-40°C TO +85°C	±.024	±.018	±.024	±.018	
4.5 TO 24.0 $\Delta\sqrt{5}$	-40°C TO +125°C	±.040	±.030	±.040	±.030	±.070

ELECTRICAL CHARACTERISTICS (OPERATING CONDITION) $\Delta\sqrt{2}$

SUPPLY VOLTAGE	V _{cc}	4.5 TO 26.5 Vdc
SUPPLY CURRENT "ON"	I _{cc}	5 TO 18.5 mA
OUTPUT VOLTAGE "ON"	V _{sat}	0 TO 0.4 Vdc (SINKING 20 mA)
OUTPUT VOLTAGE "ON"	V _{sat}	0 TO 0.5 Vdc (SINKING 40mA)
OUTPUT CURRENT "OFF"	I _{leak}	0 TO 10 μ A (PULLED UP TO 24 Vdc MAX)
OUTPUT SWITCHING RISE TIME	t _r	0 TO 1.5 μ S (V _{cc} 12V, R _{load} 1K OHM, C _{load} 20pF MAX 25°C)
OUTPUT SWITCHING FALL TIME	t _f	0 TO 1.0 μ S (V _{cc} 12V, R _{load} 1K OHM, C _{load} 20pF MAX 25°C)
REVERSE SUPPLY VOLTAGE CURRENT	I _{ccr}	-2.5 TO 0 mA (-30 VOLT SUPPLY, 0 VOLT OUTPUT APPLIED)

ABSOLUTE MAXIMUM RATINGS $\Delta\sqrt{3}\Delta\sqrt{4}$

SUPPLY VOLTAGE	±30 VDC
VOLTAGE APPLIED TO OUTPUT	-0.5VDC TO +30VDC
OUTPUT CURRENT	±50mA
TEMPERATURE	-40°C TO +150°C
TRANSIENT SUPPLY CURRENT	±0.5 AMP 15 μ S MAX
TRANSIENT OUTPUT CURRENT	±0.5 AMP 15 μ S MAX

勝特力材料 886-3-5753170
 勝特力电子(上海) 86-21-34970699
 勝特力电子(深圳) 86-755-83298787
[Http://www.100y.com.tw](http://www.100y.com.tw)

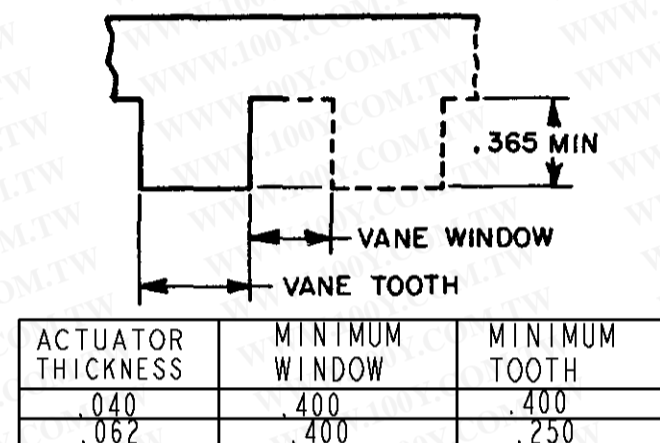
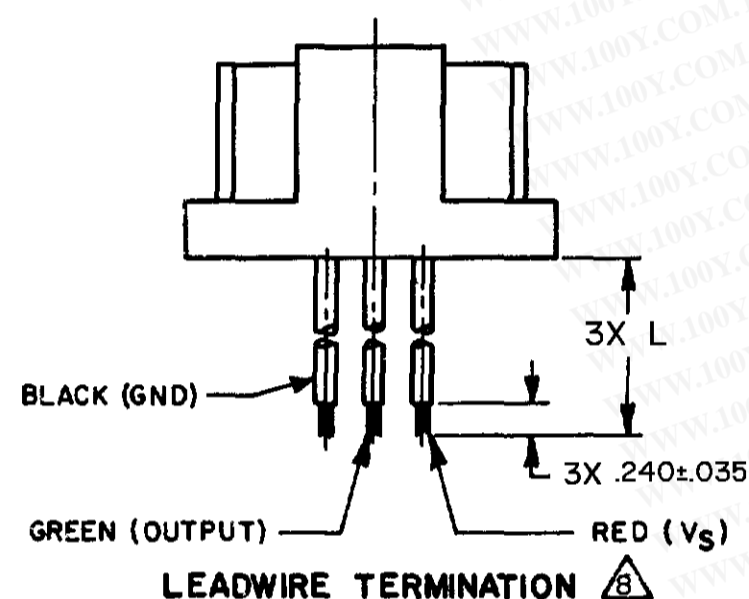
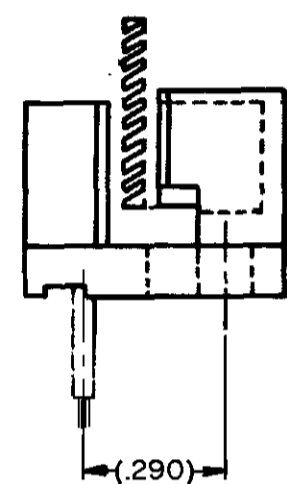
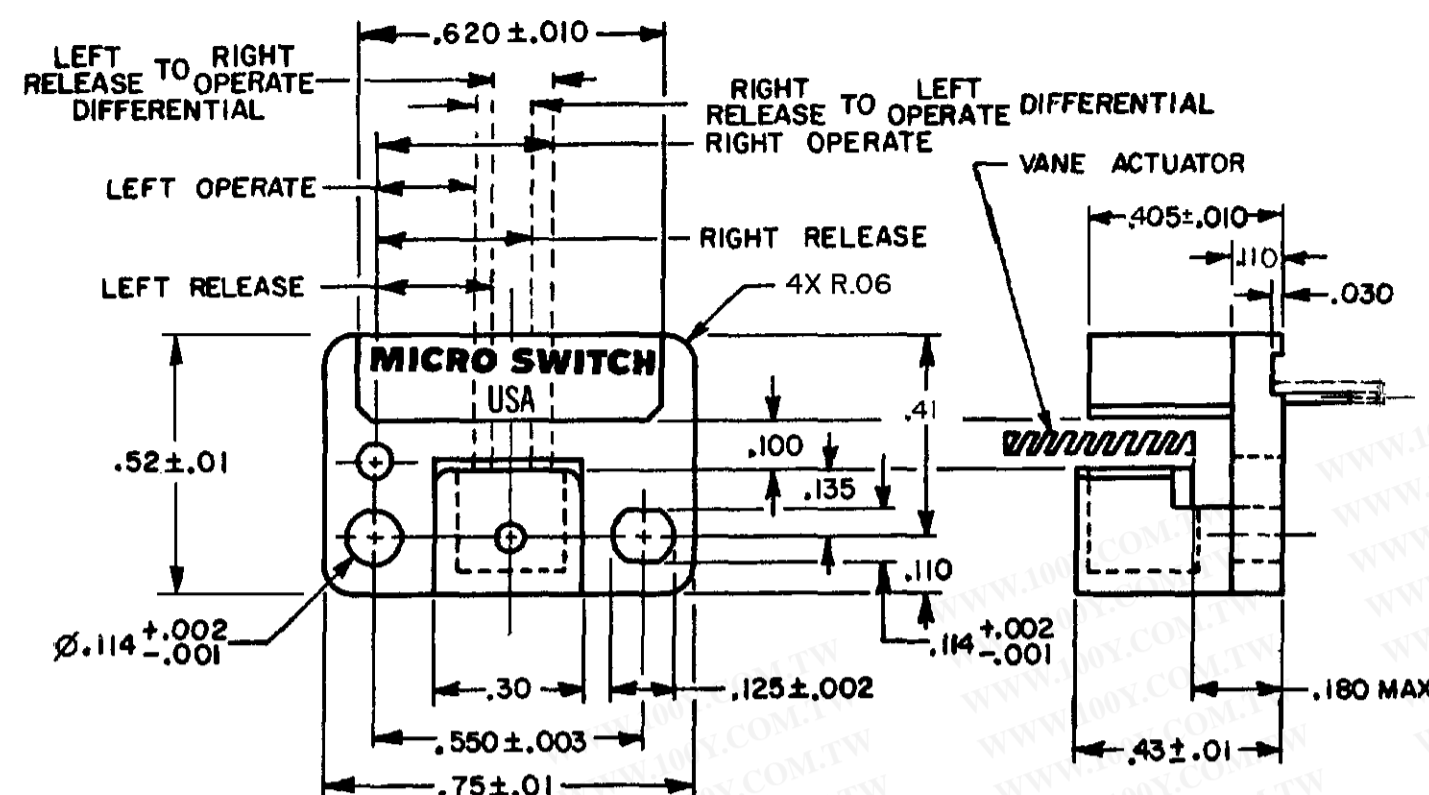

VANE ACTUATOR
 (MATERIAL TO BE ANNEALED 1010-1018 COLD ROLLED STEEL OR LOWER IN CARBON)

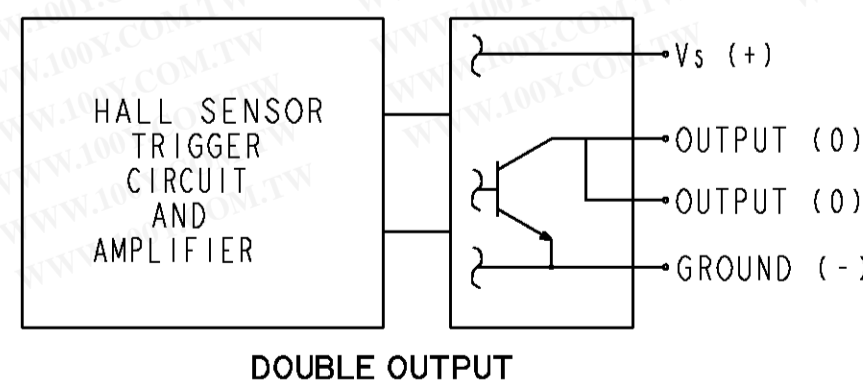
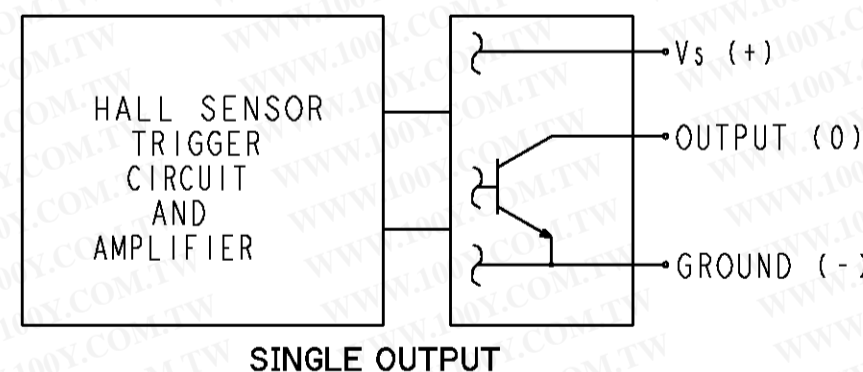
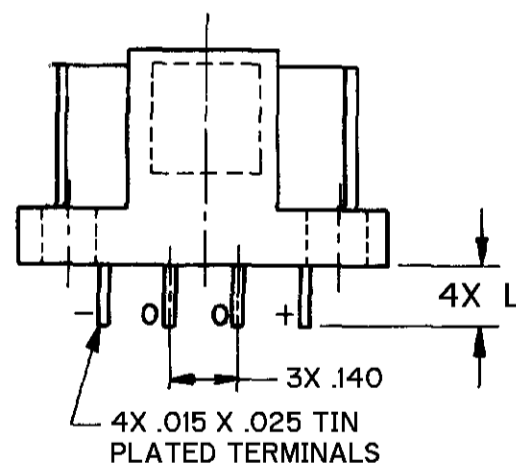
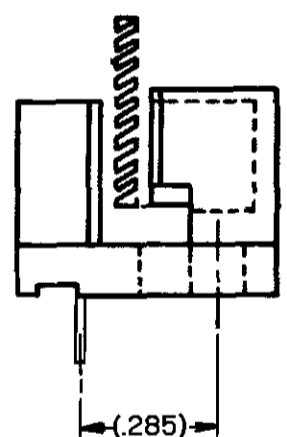

BLOCK DIAGRAM SHOWING CURRENT SINKING OUTPUT

CATALOG LISTING	OUTPUT STYLE	TERMINAL STYLE	DIM. L
4AV15F	SINGLE	LEADWIRE	5.50±.25
4AV16F	SINGLE	LEADWIRE	7.45±.25
4AV17F	SINGLE	LEADWIRE	13.15±.50
4AV18F	SINGLE	LEADWIRE	18.15±.50
4AV19F	SINGLE	LEADWIRE	22.0±.5
4AV20F	DOUBLE	PCB	.140±.035
4AV20F-T1	AMP	TERMINAL	$\Delta\sqrt{1}$
4AV20F-T2	MOLEX	TERMINAL	$\Delta\sqrt{9}$

TRANSIENT CHARACTERISTICS (REFERENCE ISO 7637-1, 25°C)

INDUCTIVE LOAD OPENING	PULSE 1	DURATION <0.2ms	-110 VOLTS
INDUCTIVE LOAD OPENING	PULSE 1	DURATION <2ms	-100 VOLTS
SERIES CURRENT INTERRUPT	PULSE 2	DURATION <200ms	+150 VOLTS
LOAD DUMP	PULSE 5	DURATION <400ms	+120 VOLTS
FIELD DECAY	PULSE 36	DURATION <100ns	+200 VOLTS
NEGATIVE TRANSIENT	PULSE 39	DURATION <100ns	-200 VOLTS
RFI	1 MHz THROUGH 1000 MHz		> 40 V/M

- NOTES
- ELECTRICAL CHARACTERISTICS SPECIFIED OVER VOLTAGE AND TEMPERATURE RANGE USING AN ACTUATOR .040 THICK WITH A .400 TOOTH AND WINDOW PASSING THROUGH THE CENTER OF THE AIR GAP
 - SWITCH IS OFF (RELEASE CONDITION) WHEN VANE ACTUATOR TOOTH IS IN THE AIR GAP
 - THE OUTPUT CURRENT MAXIMUM IS TOTAL OF OUTPUT SINKING CURRENTS
 - ABSOLUTE MAXIMUM RATINGS ARE THE EXTREME LIMITS THAT THE DEVICE WILL WITHSTAND WITHOUT DAMAGE. HOWEVER, THE ELECTRICAL AND MECHANICAL CHARACTERISTICS ARE NOT GUARANTEED ABOVE THE RECOMMENDED OPERATING CONDITIONS NOR WILL THE DEVICE NECESSARILY FUNCTION. RATINGS ARE TO BE CONSIDERED INDIVIDUALLY, NOT COMBINED
 - MAXIMUM CHANGE IN VANE TRAVEL MECHANICAL CHARACTERISTICS SWITCHING POINT REFERENCING 25°C AND 12Vdc INITIAL CONDITION
 - PRODUCT PERFORMANCE EVALUATED PER TS 060 192
 - WHEN HAND SOLDERING PRINTED CIRCUIT, BOARD TERMINATIONS, USE A ϕ .125 THERMISTATICALLY CONTROLLED TIP OF 550°F AND APPLY TO THE TERMINALS NO LONGER THAN 6 SECONDS
 - LEADWIRES ARE 24 AWG WITH CROSSLINK POLYETHYLENE INSULATION OF ϕ .060 MAX O.D.
 - MOLEX TERMINAL 22-05-3041 LOCKING FEATURE ON T2 LISTINGS MATE WITH MOLEX HOUSING 2695/6471
 - WILL MATE WITH AMP HOUSING NO.87499-B ON T1 LISTINGS ONLY
 - AMP TERMINALS 103323-4
 - LISTINGS 4AV20F-T1 AND 4AV20F-T2 HAVE A MAXIMUM TEMPERATURE RATING OF 85° C DUE TO TERMINAL BLOCK LIMITATIONS

ANSI Y14.5M 1982 APPLIES MASTER REDUCED

MICRO SWITCH
 a Honeywell Division
 FED. MFG. CODE 91929

SOLID STATE VANE SWITCH

CATALOG LISTING
4AV SERIES CHART 4

THIRD ANGLE PROJECTION

SCALE 3:1

DO NOT SCALE PRINT

UNLESS OTHERWISE SPECIFIED TOLERANCES ARE

ONE PLACE (.0)	±.030
TWO PLACES (.00)	±.015
THREE PLACES (.000)	±.005
ANGLES	±

WEIGHT

DRAWING NUMBER: 4AV SERIES CHART 4
 PAGE 1 OF 2
 ISSUE: 5
 CHECK: J A F 11 MAY 98
 RELEASE NO.: DR-5009
 X102209-AV
 REVISIONS:
 A CO-93446 8 J W 22 SEP 98
 B PR-23514 2 OCT 98
 C CO93789 26 OCT 98
 D CO-94108-A 19 FEB 99
 FORMTEK
 J J A 11 MAY 98
 DRAWN: J A F 11 MAY 98

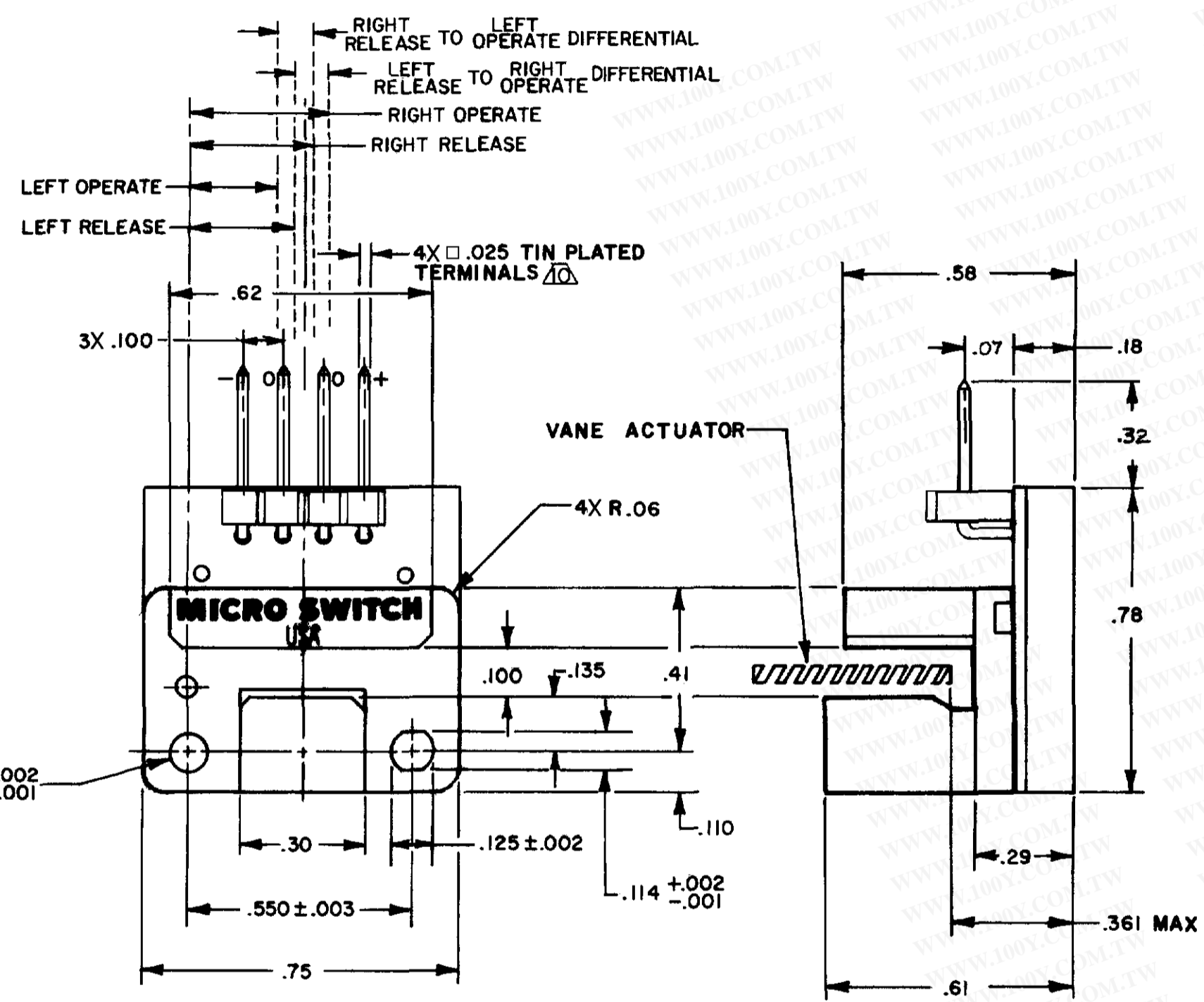
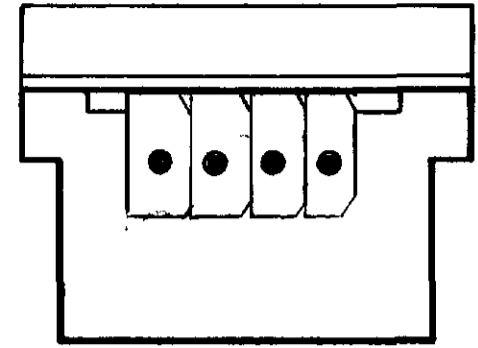
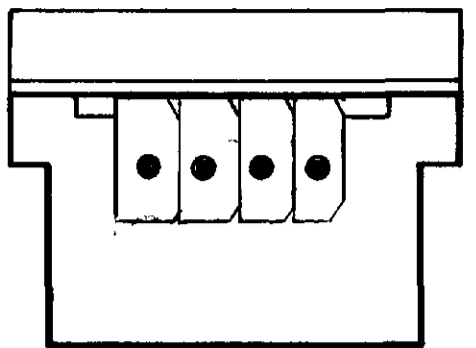

STYLE T1

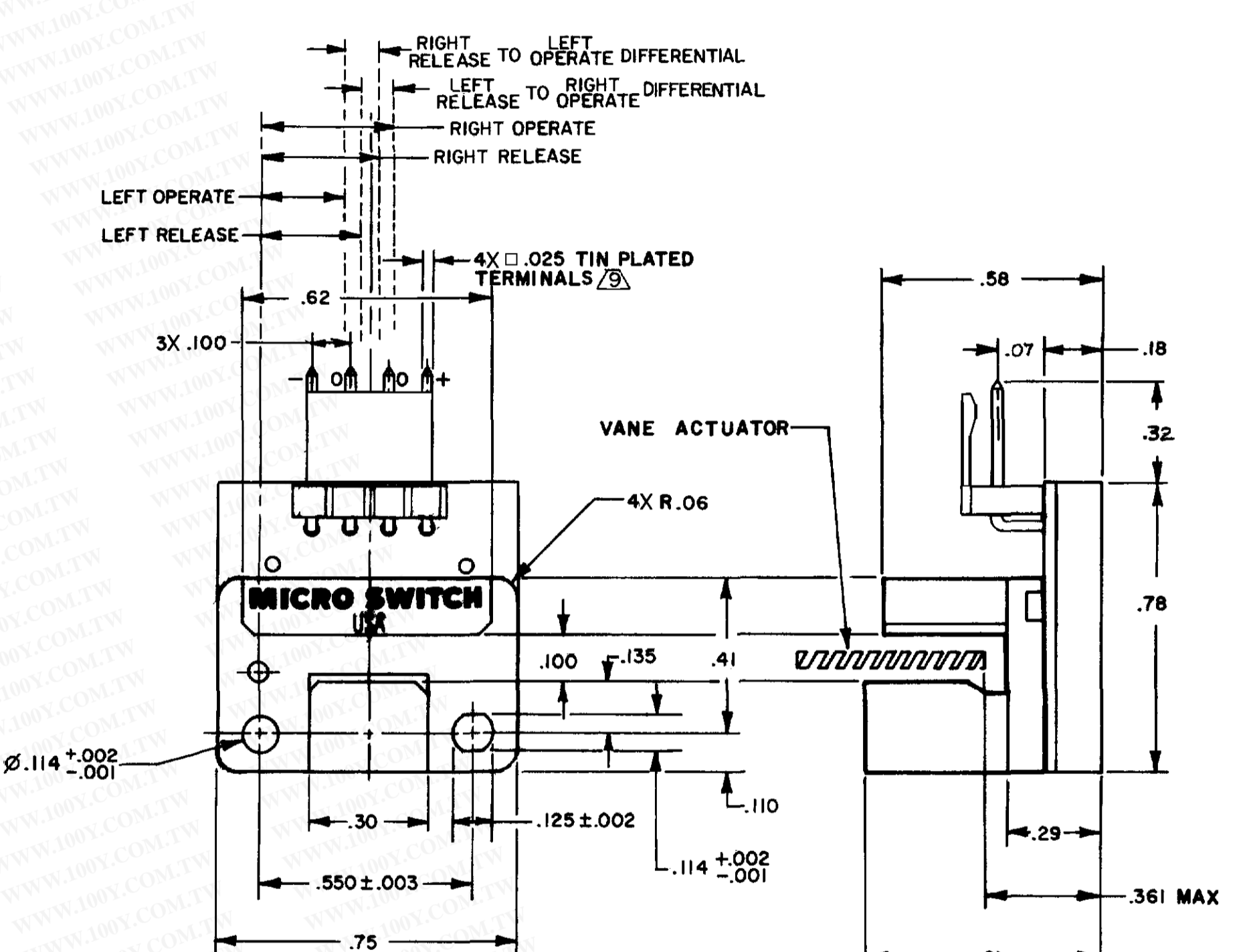

STYLE T2

勝特力材料 886-3-5753170
 勝特力电子(上海) 86-21-34970699
 勝特力电子(深圳) 86-755-83298787
[Http://www.100y.com.tw](http://www.100y.com.tw)

DRAWING NUMBER: 4AV SERIES CHART 4
 PAGE 2 OF 2
 ISSUE 5
 X102209-AV
 REPLACES DR-5009
 CHECK J A F 11 MAY 98
 DRAWN J A F 11 MAY 98
 FORMTEK

REVISIONS

A	PR-23514	01	2 OCT 98
B	C093789	01	26 OCT 98
C	94108-A	01	19 FEB 99

ANSI Y14.5M 1982 APPLIES
 MASTER REDUCED

MICRO SWITCH a Honeywell Division <small>FED. MFG. CODE 91929</small>	SOLID STATE VANE SWITCH	CATALOG LISTING 4AV SERIES CHART 4	THIRD ANGLE PROJECTION
		SCALE 3:1 DO NOT SCALE PRINT UNLESS OTHERWISE SPECIFIED TOLERANCES ARE ONE PLACE (.0) ±.030 TWO PLACES (.00) ±.015 THREE PLACES (.000) ±.005 ANGLES ± WEIGHT	