

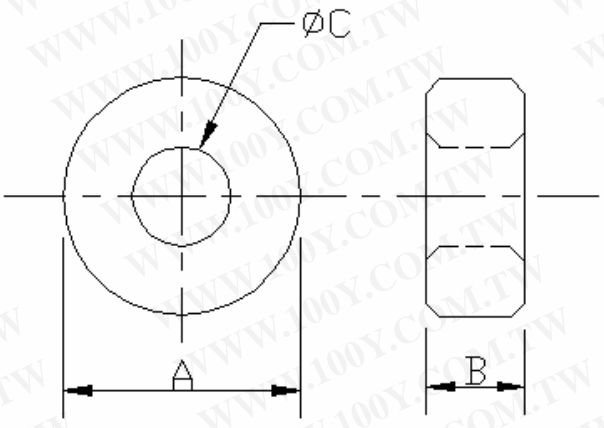

SPECIFICATION FOR APPROVAL

CUSTOMER:		CUST.P/N:	
ORDERING CODE:	A5 T 31x7x19-CG	K.C.P/N:	
(1) SHAPE : 	A	31.0+1.8(-0.8) mm	
	B	7.0+1.3(-0.3) mm	
	C	19.0+0.5(-1.5) mm	
	D	mm	
	E	mm	
	F	mm	
	G	mm	
(2) ELECTRICAL REQUIREMENTS: $Z_1 = 88 \text{ min OHM AT } 25 \text{ MHz}$ $Z_2 = 150 \text{ min OHM AT } 100 \text{ MHz}$	(3) TEST CONDITIONS: 1 IMPEDANCE ANALYZER HP4191A TEST FIXTURE: HP16092A 2. WIRE: $\Phi 0.6$ 2UEW 2Ts 3. DRAWING:		
	<div style="border: 2px solid red; padding: 5px; color: red;"> 勝特力材料 886-3-5753170 勝特力电子(上海) 86-21-54151736 勝特力电子(深圳) 86-755-83298787 Http://www.100y.com.tw </div>		
(4) PACKING <input type="checkbox"/> IN BULK <input checked="" type="checkbox"/> VACUUM <input type="checkbox"/> INSERTION PCS/BAG* BAGS/INNER BOX: BOXES/CARTON = PCS 40 PCS/PLATE* 12 PLATES/CARTON= 480 PCS PCS/TRAY* TRAYS/CARTON= PCS	(5) APPEARANCE (1) AREA OF BREAK : < 4 mm ² (2) SUM OF BREAKING AREA : < 5 mm ² (3) DEPTH OF BREAK : < 1 mm		
	(6) REMARK: COATING TYPE: EPOXY COATING COLOR: GREEN		
	Approved by 吳炳勳		
	Checked by 吳明珠		
Drawn by 許雅南 2009/10/26			
DWG.NO.			

TEST DATA FOR PREPRODUCTION SAMPLES

CUSTOMER					CUST. P/N	勝特力材料 886-3-5753170 勝特力电子(上海) 86-21-54151736 勝特力电子(深圳) 86-755-83298787 Http://www.100y.com.tw
ORDERING CODE	A5 T 31x7x19-CG				K.C. P/N	
TEMP.	24 °C	RH	69 %	DWG.NO.		
WIRE	0.6 ϕ_{ZUEW}	WINDING	2 Ts	Q'TY	5PCS	
Test Instruments						
Meas. Item.	Z (OHM)	Z (OHM)	A mm	B mm	C mm	
Spec./ Yours.						
Spec./Suggest.	88 min	150 min	31.0+1.8(-0.8)	7.0+1.3(-0.3)	19.0+0.5(-1.5)	
Test Freq.	25 MHZ	100 MHZ				
1	116	227	31.12	7.50	18.52	
2	114	223	31.15	7.51	18.63	
3	116	228	31.18	7.48	18.54	
4	112	225	31.10	7.62	18.54	
5	114	221	31.22	7.37	18.47	
6						
7						
8						
9						
10						
\bar{X}	114.4	224.8	31.154	7.496	18.540	
R	4	7	0.12	0.25	0.16	
Your Sample.						
REMARK:					Approved by: 吳炳勳	
					Checked by: 吳明珠	
					Drawn by: 許雅南	
2009/10/26						

勝特力材料 886-3-5753170
勝特力电子(上海) 86-21-54151736
勝特力电子(深圳) 86-755-83298787
[Http://www.100y.com.tw](http://www.100y.com.tw)

A5 T 31x7x19-CG

