



SMT inductors

SIMID series, SIMID 1812-T

Series/Type: **B82432T**

Date: June 2019

勝特力材料 886-3-5753170
勝特力电子(上海) 86-21-34970699
勝特力电子(深圳) 86-755-83298787
[Http://www.100y.com.tw](http://www.100y.com.tw)

© TDK Electronics AG 2019. Reproduction, publication and dissemination of this publication, enclosures hereto and the information contained therein without TDK Electronics' prior express consent is prohibited.

SIMID 1812-T
SMD

Size 1812 (EIA) or 4532 (IEC)
Rated inductance 1 ... 1000 μ H
Rated current 70 ... 1300 mA

Construction

- Upright ferrite drum core
- Laser-welded winding
- Flame-retardant molding

Features

- Temperature range up to +150 °C
- High current handling capability
- Qualified to AEC-Q200
- Suitable for lead-free reflow soldering as referenced in JEDEC J-STD 020D
- RoHS-compatible

Applications

- Filtering of supply voltages, coupling, decoupling
- DC/DC converters
- Automotive electronics (e.g. single-wire bus systems)
- Telecommunications
- Industrial electronics

Terminals

- Base material CuSn6
- Layer composition Cu, Ag, Sn (lead-free)¹⁾
- Electro-plated

Marking

- Marking on component:
 Manufacturer and letter "T",
 L value (in μ H), tolerance of L value (coded),
 date of manufacture (YWWD)
- Minimum data on reel:
 Manufacturer, ordering code, L value, quantity, date of packing

Delivery mode and packing unit

- 12-mm blister tape, wound on 330-mm \varnothing reel
- Packing unit: 2500 pcs./reel

1) Ni-barrier-plated terminals on request (B82432T*50).

SIMID 1812-T

SMD

Dimensional drawing and layout recommendation

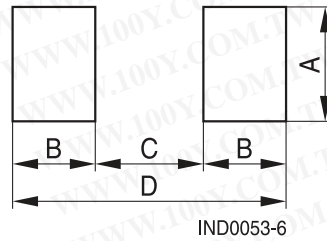
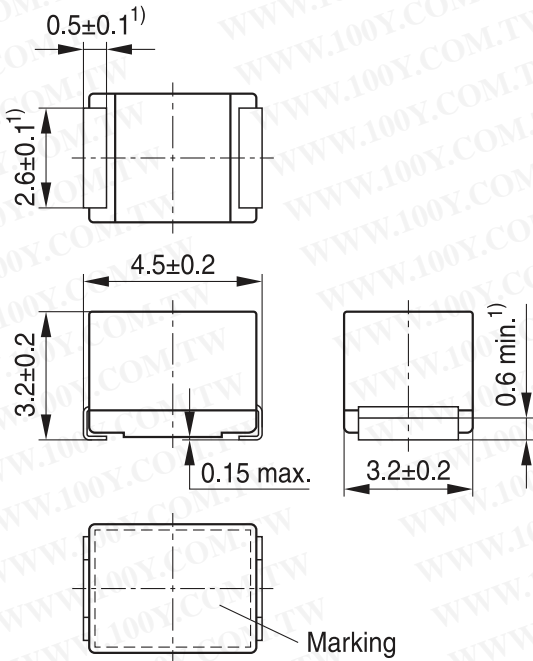

A	B	C	D
3.6	1.3	3.2	5.8

1) Soldering area

IND0083-T-E

Dimensions in mm

Taping and packing

Blister tape

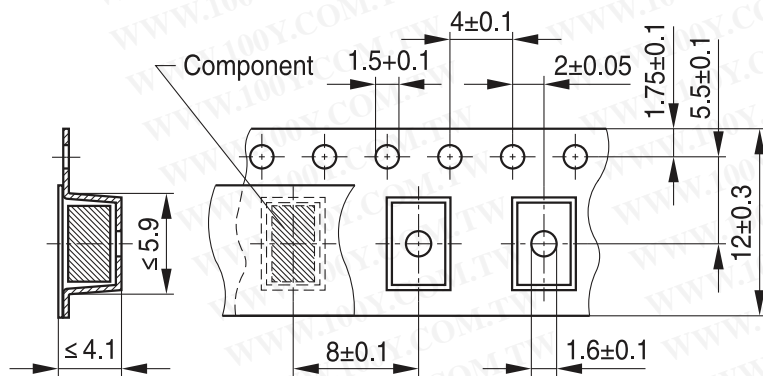

Reel

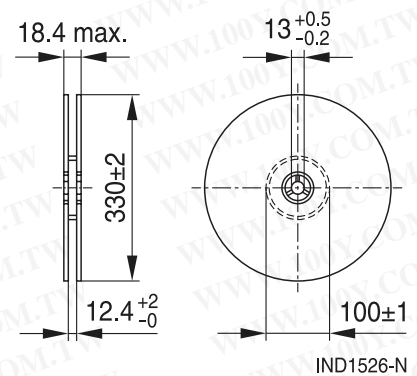

Direction of unreeling

IND0561-L-E

Dimensions in mm

SMD
Technical data and measuring conditions

Rated inductance L_R	Measured with impedance analyzer Agilent 4294A or equivalent at frequency f_L , 0.1 V, +20 °C
Q factor Q_{\min}	Measured with impedance analyzer Agilent 4294A or equivalent at frequency f_Q , +20 °C
Rated temperature T_R	+85 °C
Rated current I_R	Maximum permissible DC with inductance decrease $\Delta L/L_0 \leq 10\%$ and temperature increase of ≤ 40 K at rated temperature
Self-resonance frequency $f_{\text{res},\min}$	Measured with impedance analyzer Agilent 4294A / E4991A or equivalent, +20 °C
DC resistance R_{\max}	Measured at +20 °C
Solderability (lead-free)	Sn95.5Ag3.8Cu0.7: +(245 ±5) °C, (5 ±0.3) s Wetting of soldering area $\geq 90\%$ (based on IEC 60068-2-58)
Resistance to soldering heat	+260 °C, 40 s (as referenced in JEDEC J-STD 020D)
Climatic category	55/150/56 (to IEC 60068-1)
Storage conditions	Mounted: -55 °C ... +150 °C Packaged: -25 °C ... +40 °C, $\leq 75\%$ RH
Weight	Approx. 130 mg

Characteristics and ordering codes

L_R μH	Tolerance	Q_{\min}	$f_L; f_Q$ MHz	I_R mA	R_{\max} Ω	$f_{\text{res},\min}$ MHz	Ordering code ¹⁾
1.0	±10% \triangleq K	10	7.96	1300	0.08	110	B82432T1102K000
1.2		10	7.96	1200	0.10	100	B82432T1122K000
1.5		10	7.96	1150	0.11	80	B82432T1152K000
1.8		10	7.96	1050	0.13	70	B82432T1182K000
2.2		10	7.96	1000	0.15	60	B82432T1222K000
2.7		10	7.96	950	0.17	55	B82432T1272K000
3.3		10	7.96	900	0.19	50	B82432T1332K000
3.9		10	7.96	850	0.20	45	B82432T1392K000
4.7		10	7.96	800	0.22	40	B82432T1472K000
5.6		10	7.96	750	0.26	38	B82432T1562K000
6.8		10	7.96	700	0.30	36	B82432T1682K000
8.2		10	7.96	670	0.33	30	B82432T1822K000

1) For Ni-barrier-plated terminals replace the last two digits "00" by "50".

SMD
Characteristics and ordering codes

L_R μH	Tolerance	Q_{\min}	$f_L; f_Q$ MHz	I_R mA	R_{\max} Ω	$f_{\text{res,min}}$ MHz	Ordering code ¹⁾
10	$\pm 10 \% \triangleq K$	10	2.52	650	0.35	25	B82432T1103K000
12		10	2.52	630	0.45	23	B82432T1123K000
15		10	2.52	600	0.50	20	B82432T1153K000
18		10	2.52	550	0.60	18	B82432T1183K000
22		10	2.52	450	0.70	15	B82432T1223K000
27		10	2.52	430	1.00	14	B82432T1273K000
33		10	2.52	400	1.20	13	B82432T1333K000
39		10	2.52	380	1.30	12	B82432T1393K000
47		10	2.52	350	1.35	11	B82432T1473K000
56		10	2.52	300	2.00	10	B82432T1563K000
68	10	2.52	250	2.50	8.0	B82432T1683K000	
82	10	2.52	220	3.00	7.0	B82432T1823K000	
100	20	20	0.796	200	3.50	6.5	B82432T1104K000
120		20	0.796	180	4.50	6.3	B82432T1124K000
150		20	0.796	160	6.00	6.1	B82432T1154K000
180		20	0.796	140	7.00	5.5	B82432T1184K000
220		20	0.796	130	7.50	4.5	B82432T1224K000
270		20	0.796	120	10.5	4.3	B82432T1274K000
330		20	0.796	120	11.0	4.1	B82432T1334K000
390		20	0.796	110	13.0	3.9	B82432T1394K000
470		20	0.796	100	15.0	3.5	B82432T1474K000
560		20	0.796	90	20.0	3.0	B82432T1564K000
680	20	0.796	80	23.0	2.6	B82432T1684K000	
820	20	0.796	80	27.0	2.4	B82432T1824K000	
1000	20	0.252	70	30.0	2.3	B82432T1105K000	

Closer tolerances on request.

Higher currents possible at temperatures $<T_R$ on request.

Sample kit available. Ordering code: B82432X001

For more information refer to chapter "Sample kits".

1) For Ni-barrier-plated terminals replace the last two digits of ordering code "00" by "50".

SMT inductors, SIMID series

SIMID 1812-T

勝特力材料 886-3-5753170
 勝特力电子(上海) 86-21-34970699
 勝特力电子(深圳) 86-755-83298787
[Http://www.100y.com.tw](http://www.100y.com.tw)

SMD

Impedance $|Z|$ versus frequency f
 measured with impedance analyzer Agilent E4991A, typical values at +20 °C

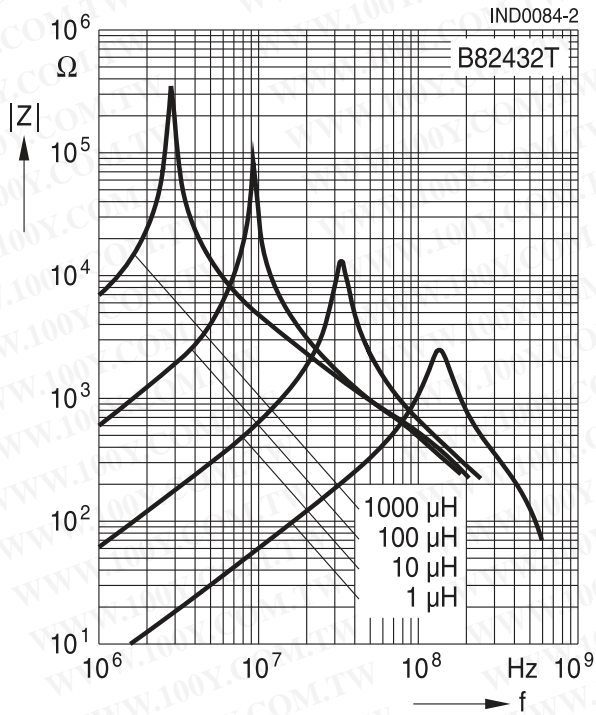

Inductance L versus DC load current I_{DC}
 measured with LCR meter Agilent 4285A, typical values at +20 °C

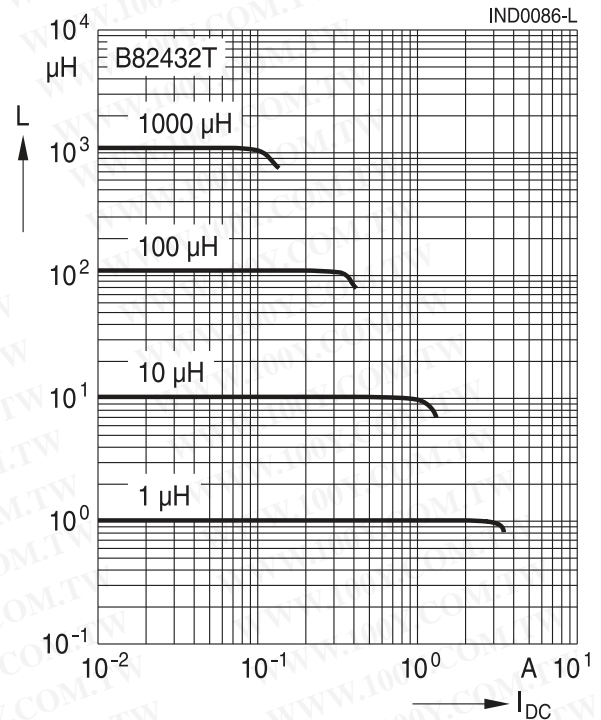

Q factor versus frequency f
 measured with impedance analyzer Agilent 4294A, typical values at +20 °C

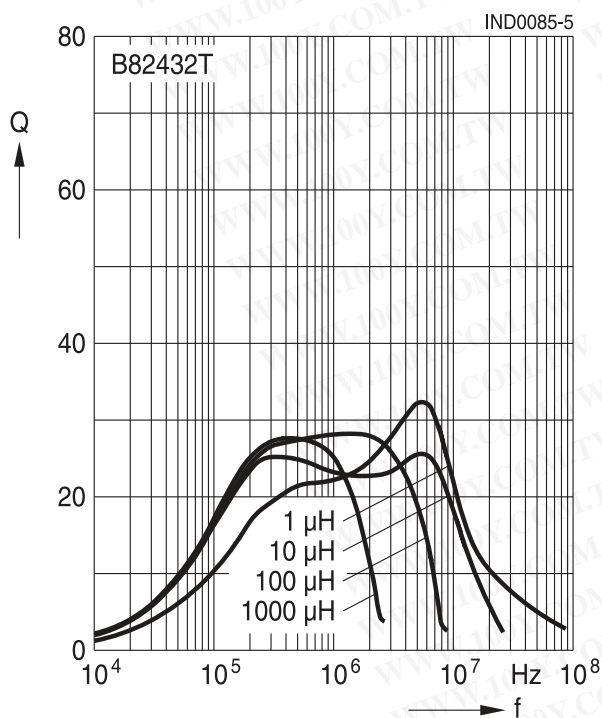

Current derating I_{op}/I_R versus ambient temperature T_A
 (rated temperature $T_R = +85$ °C)

