

**Description**

- 165°C maximum total temperature operation
- Five sizes of Automotive grade shielded drum core inductors
- Inductance range from 0.28uH to 1000uH
- Current range up to 56 Amperes
- Mechanical secure mounting for high shock and vibration environments
- Good thermal dispersion with thermal conductive epoxy
- Customized dual winding versions available upon request for SEPIC or Flyback configurations

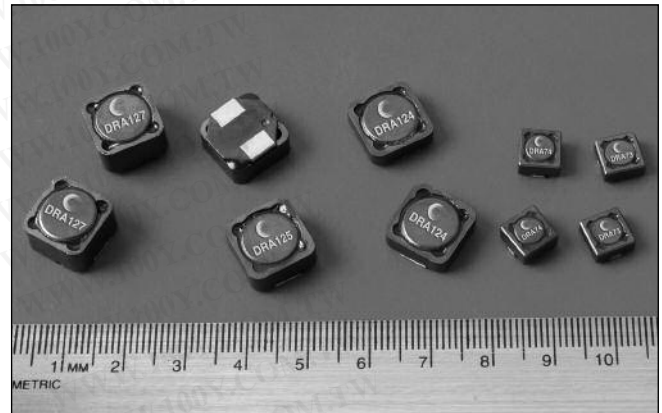

**Applications**

- Automotive Electronics (under the hood, interior/exterior)
- Telematics
- DC-DC converters
- Buck, boost, forward, and resonant converters
- Noise filtering and filter chokes

**Environmental Data**

- Storage temperature range: -40°C to +165°C
- Operating temperature range: -40°C to +165°C (range is application specific)
- Solder reflow temperature: +260°C max. for 10 seconds max.
- Complies with AEC-Q200 standard

**Packaging**

- Supplied in tape and reel packaging, 1350 (DRA73), 1100 (DRA74), 750 (DRA124), 600 (DRA125), and 350 (DRA127) per reel

Part Number	Rated Inductance	OCL (1) µH +/-20%	Irms (2) Amperes	Isat (3) Amperes	Isat (4) Amperes	DCR (5) (Ω) Typ.	K-factor (6)
DRA73-R33-R	0.33	0.29	8.42	14.80	11.84	0.0040	60.6
DRA73-1R0-R	1.00	0.91	6.50	8.22	6.58	0.0067	33.7
DRA73-1R5-R	1.50	1.36	5.39	6.73	5.38	0.0097	27.5
DRA73-2R2-R	2.20	2.52	4.18	4.93	3.95	0.016	20.2
DRA73-3R3-R	3.30	3.18	3.59	4.35	3.48	0.022	17.8
DRA73-4R7-R	4.70	4.86	2.92	3.52	2.82	0.033	14.4
DRA73-6R8-R	6.80	6.63	2.62	2.96	2.37	0.041	12.1
DRA73-8R2-R	8.20	8.06	2.30	2.74	2.19	0.053	11.2
DRA73-100-R	10.0	10.27	2.11	2.39	1.91	0.064	9.8
DRA73-150-R	15.0	14.98	1.74	2.00	1.60	0.094	8.2
DRA73-220-R	22.0	22.39	1.42	1.64	1.32	0.141	6.7
DRA73-330-R	33.0	31.84	1.25	1.35	1.08	0.183	5.5
DRA73-470-R	47.0	47.83	1.02	1.10	0.884	0.275	4.5
DRA73-680-R	68.0	66.89	0.845	0.937	0.749	0.397	3.8
DRA73-820-R	82.0	83.77	0.731	0.851	0.680	0.530	3.5
DRA73-101-R	100	101.7	0.682	0.763	0.610	0.609	3.1
DRA73-151-R	150	151.1	0.551	0.632	0.506	0.932	2.6
DRA73-221-R	220	218.8	0.479	0.510	0.408	1.23	2.1
DRA73-331-R	330	326.4	0.391	0.423	0.338	1.85	1.7
DRA73-471-R	470	472.6	0.326	0.354	0.283	2.67	1.4
DRA73-681-R	680	682.9	0.270	0.297	0.238	3.89	1.2
DRA73-821-R	820	825.3	0.252	0.267	0.214	4.46	1.1
DRA73-102-R	1000	991.9	0.235	0.239	0.192	5.15	1.0

(1) Open Circuit Inductance test parameters: 100kHz, 0.25V, 0.0Aac, tolerance is ±20%  
 (2) Irms: DC current for an approximate ΔT of 40°C without core loss. Derating is necessary for AC currents. PCB layout, trace thickness and width, air-flow, and proximity of other heat generating components will affect the temperature rise. It is recommended that the temperature of the part not exceed 165°C under worst case operating conditions verified in the end application.  
 (3) Isat Amperes peak for approximately 30% rolloff (@25°C)  
 (4) Isat Amperes peak for approximately 40% rolloff (@125°C)

(5) DCR limits @ 25°C  
 (6) K-factor: Used to determine B p-p for core loss (see graph).  
 $B\ p-p = K \cdot L \cdot \Delta I$ , B p-p(mT), K: (K factor from table), L: (Inductance in µH), ΔI (Peak to peak ripple current in Amperes).  
 (7) Part Number Definition: DRAxxx-xxx-R  
 DRAxxx = Product code and size; -xxx = Inductance value in µH;  
 R = decimal point; If no R is present, third character = # of zeros.  
 -R suffix = RoHS compliant

Part Number	Rated Inductance	OCL (1) μH ±20%	Irms (2) Amperes	Isat (3) Amperes	Isat (4) Amperes	DCR (5) (Ω) Typ.	K-factor (6)
DRA74-R33-R	0.33	0.288	7.26	18.40	14.72	0.0054	52.6
DRA74-1R0-R	1.00	0.897	6.01	10.22	8.18	0.0078	29.2
DRA74-1R5-R	1.50	1.31	5.55	8.36	6.69	0.0092	23.9
DRA74-2R2-R	2.20	2.33	4.82	6.13	4.91	0.012	17.5
DRA74-3R3-R	3.30	3.05	4.16	5.41	4.33	0.016	15.5
DRA74-4R7-R	4.70	4.68	3.41	4.38	3.50	0.024	12.5
DRA74-6R8-R	6.80	6.51	2.91	3.68	2.94	0.034	10.5
DRA74-8R2-R	8.20	8.51	2.66	3.17	2.54	0.040	9.1
DRA74-100-R	10.0	9.62	2.56	2.97	2.37	0.043	8.5
DRA74-150-R	15.0	15.14	2.06	2.36	1.89	0.067	6.7
DRA74-220-R	22.0	22.25	1.68	1.96	1.57	0.100	5.6
DRA74-330-R	33.0	33.21	1.37	1.61	1.29	0.151	4.6
DRA74-470-R	47.0	46.56	1.14	1.37	1.099	0.219	3.9
DRA74-680-R	68.0	68.37	0.996	1.108	0.887	0.286	3.2
DRA74-820-R	82.0	81.45	0.879	1.034	0.827	0.367	3.0
DRA74-101-R	100	98.5	0.822	0.929	0.743	0.419	2.7
DRA74-151-R	150	150.9	0.661	0.748	0.598	0.648	2.1
DRA74-221-R	220	218.9	0.544	0.626	0.501	0.96	1.8
DRA74-331-R	330	328.9	0.435	0.514	0.411	1.50	1.5
DRA74-471-R	470	471.5	0.383	0.420	0.336	1.93	1.2
DRA74-681-R	680	682.8	0.315	0.352	0.282	2.86	1.0
DRA74-821-R	820	815.0	0.279	0.327	0.262	3.63	0.9
DRA74-102-R	1000	1001.7	0.260	0.292	0.234	4.19	0.8
DRA124-R47-R	0.47	0.423	15.15	30.80	24.6	0.0019	16.7
DRA124-1R0-R	1.00	0.821	11.65	22.00	17.6	0.0031	12.0
DRA124-1R5-R	1.50	1.36	9.36	17.11	13.7	0.0049	9.3
DRA124-2R2-R	2.20	2.04	7.64	14.00	11.2	0.007	7.6
DRA124-3R3-R	3.30	2.79	6.94	11.85	9.48	0.009	6.4
DRA124-4R7-R	4.70	4.74	5.47	9.06	7.25	0.014	4.9
DRA124-6R8-R	6.80	7.28	4.46	7.33	5.87	0.021	4.0
DRA124-8R2-R	8.20	8.88	3.87	6.70	5.36	0.028	3.6
DRA124-100-R	10.0	10.37	3.67	6.16	4.93	0.031	3.3
DRA124-150-R	15.0	14.10	3.10	5.31	4.25	0.044	2.9
DRA124-220-R	22.0	23.00	2.44	4.16	3.33	0.071	2.3
DRA124-330-R	33.0	34.13	1.98	3.42	2.74	0.108	1.9
DRA124-470-R	47.0	46.27	1.78	2.91	2.325	0.134	1.6
DRA124-680-R	68.0	69.77	1.454	2.369	1.895	0.201	1.3
DRA124-820-R	82.0	80.57	1.285	2.232	1.786	0.257	1.2
DRA124-101-R	100	98.8	1.199	2.000	1.600	0.296	1.1
DRA124-151-R	150	151.7	0.967	1.621	1.297	0.454	0.9
DRA124-221-R	220	209.6	0.865	1.363	1.090	0.568	0.7
DRA124-331-R	330	326.9	0.690	1.092	0.874	0.892	0.6
DRA124-471-R	470	473.0	0.568	0.911	0.729	1.32	0.5
DRA124-681-R	680	682.1	0.466	0.759	0.607	1.96	0.4
DRA124-821-R	820	826.7	0.406	0.697	0.557	2.57	0.4
DRA124-102-R	1000	1001.0	0.380	0.629	0.503	2.94	0.3
DRA125-R47-R	0.47	0.453	18.47	33.20	26.56	0.0016	16.7
DRA125-1R0-R	1.00	0.854	15.94	23.71	18.97	0.0021	12.0
DRA125-1R5-R	1.50	1.41	12.89	18.44	14.76	0.0033	9.3
DRA125-2R2-R	2.20	2.12	10.61	15.09	12.07	0.0048	7.6
DRA125-3R3-R	3.30	2.89	9.69	12.77	10.22	0.0058	6.4
DRA125-4R7-R	4.70	4.90	7.67	9.76	7.81	0.0092	4.9
DRA125-6R8-R	6.80	6.23	6.81	8.74	6.99	0.012	4.4
DRA125-8R2-R	8.20	7.49	6.41	7.90	6.32	0.013	4.0
DRA125-100-R	10.0	9.22	5.57	7.22	5.77	0.017	3.6

(1) Open Circuit Inductance test parameters: 100kHz, 0.25V, 0.0Aac, tolerance is ±20%

(2) Irms: DC current for an approximate ΔT of 40°C without core loss. Derating is necessary for AC currents. PCB layout, trace thickness and width, air-flow, and proximity of other heat generating components will affect the temperature rise. It is recommended that the temperature of the part not exceed 165°C under worst case operating conditions verified in the end application.

(3) Isat Amperes peak for approximately 30% rolloff (@25°C)

(4) Isat Amperes peak for approximately 40% rolloff (@125°C)

(5) DCR limits @ 25°C

(6) K-factor: Used to determine B p-p for core loss (see graph).  
 $B p-p = K \cdot L \cdot \Delta I$ , B p-p(mT), K: (K factor from table), L: (Inductance in μH),  
 ΔI (Peak to peak ripple current in Amps).

(7) Part Number Definition: DRAxxx-xxx-R

DRAxxx = Product code and size; -xxx = Inductance value in μH;  
 R = decimal point; If no R is present, third character = # of zeros.  
 -R suffix = RoHS compliant

Part Number	Rated Inductance	OCL (1) μH +/-20%	Irms (2) Amperes	Isat (3) Amperes	Isat (4) Amperes	DCR (5) (Ω) Typ.	K-factor (6)
DRA125-150-R	15.0	14.67	4.45	5.72	4.58	0.027	2.9
DRA125-220-R	22.0	20.65	3.95	4.74	3.79	0.035	2.4
DRA125-330-R	33.0	31.47	3.19	3.86	3.09	0.053	1.9
DRA125-470-R	47.0	47.83	2.59	3.13	2.506	0.081	1.6
DRA125-680-R	68.0	68.48	2.125	2.635	2.108	0.120	1.3
DRA125-820-R	82.0	80.86	2.005	2.406	1.925	0.135	1.2
DRA125-101-R	100	97.6	1.745	2.213	1.771	0.178	1.1
DRA125-151-R	150	150.0	1.409	1.785	1.428	0.273	0.9
DRA125-221-R	220	222.8	1.142	1.469	1.175	0.416	0.7
DRA125-331-R	330	325.1	0.998	1.194	0.955	0.543	0.6
DRA125-471-R	470	466.3	0.826	1.006	0.805	0.79	0.5
DRA125-681-R	680	683.3	0.673	0.834	0.667	1.20	0.4
DRA125-821-R	820	813.6	0.632	0.758	0.606	1.36	0.4
DRA125-102-R	1000	992.8	0.552	0.695	0.556	1.78	0.4
DRA127-R47-R	0.47	0.413	22.50	56.0	44.8	0.0012	14.3
DRA127-1R0-R	1.00	0.772	19.22	40.0	32.0	0.0017	10.2
DRA127-1R5-R	1.50	1.27	15.32	31.1	24.9	0.0027	7.9
DRA127-2R2-R	2.20	1.92	12.52	25.5	20.4	0.0040	6.5
DRA127-3R3-R	3.30	3.51	9.59	18.7	14.93	0.0068	4.8
DRA127-4R7-R	4.70	4.58	8.14	16.5	13.18	0.0094	4.2
DRA127-6R8-R	6.80	6.72	7.32	13.3	10.67	0.012	3.4
DRA127-8R2-R	8.20	8.33	6.33	12.2	9.74	0.016	3.1
DRA127-100-R	10.0	9.63	6.02	11.2	8.96	0.017	2.9
DRA127-150-R	15.0	14.90	4.83	9.03	7.23	0.027	2.3
DRA127-220-R	22.0	21.47	3.98	7.57	6.05	0.040	1.9
DRA127-330-R	33.0	32.01	3.22	6.22	4.98	0.060	1.6
DRA127-470-R	47.0	47.91	2.62	5.09	4.07	0.091	1.3
DRA127-680-R	68.0	68.22	2.333	4.18	3.34	0.115	1.1
DRA127-820-R	82.0	83.91	2.008	3.84	3.07	0.155	1.0
DRA127-101-R	100	100.8	1.888	3.46	2.77	0.175	0.9
DRA127-151-R	150	151.2	1.524	2.83	2.26	0.269	0.7
DRA127-221-R	220	219.8	1.253	2.35	1.88	0.398	0.6
DRA127-331-R	330	328.3	1.011	1.93	1.54	0.612	0.5
DRA127-471-R	470	474.5	0.827	1.62	1.29	0.91	0.4
DRA127-681-R	680	676.6	0.736	1.33	1.06	1.15	0.3
DRA127-821-R	820	824.6	0.637	1.22	0.978	1.54	0.3
DRA127-102-R	1000	998.7	0.598	1.10	0.878	1.75	0.3

- (1) Open Circuit Inductance test parameters: 100kHz, 0.25V, 0.0A<sub>dc</sub>, tolerance is ±20%  
 (2) I<sub>rms</sub>: DC current for an approximate ΔT of 40°C without core loss. Derating is necessary for AC currents. PCB layout, trace thickness and width, air-flow, and proximity of other heat generating components will affect the temperature rise. It is recommended that the temperature of the part not exceed 165°C under worst case operating conditions verified in the end application.  
 (3) Isat Amperes peak for approximately 30% rolloff (@25°C)  
 (4) Isat Amperes peak for approximately 40% rolloff (@125°C)

- (5) DCR limits @ 25°C  
 (6) K-factor: Used to determine B p-p for core loss (see graph).  
 $B_{p-p} = K \cdot L \cdot \Delta I$ , B p-p(mT), K: (K factor from table), L: (Inductance in μH), ΔI (Peak to peak ripple current in Amps).  
 (7) Part Number Definition: DRAxxx-xxx-R  
 DRAxxx = Product code and size; -xxx = Inductance value in μH;  
 R = decimal point; If no R is present, third character = # of zeros.  
 -R suffix = RoHS compliant

**Mechanical Diagrams**

**DRA73 Series**

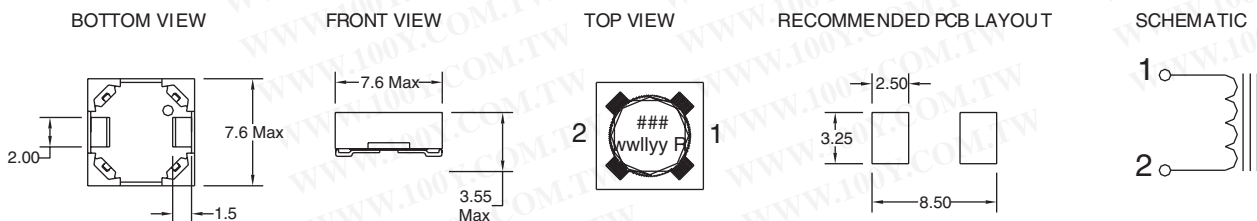

Dimensions in Millimeters.

### = Inductance value in μH. R = decimal point.  
 If no R is present third character = # of zeros  
 willy = (date code) R = revision level

**Mechanical Diagrams**

**DRA74 Series**

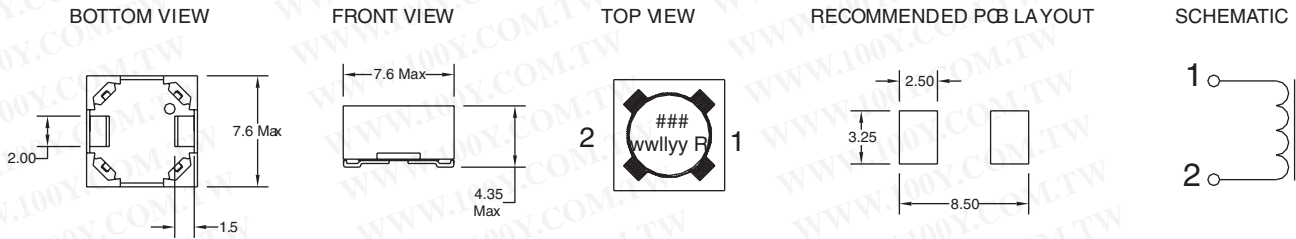

**DRA124 Series**

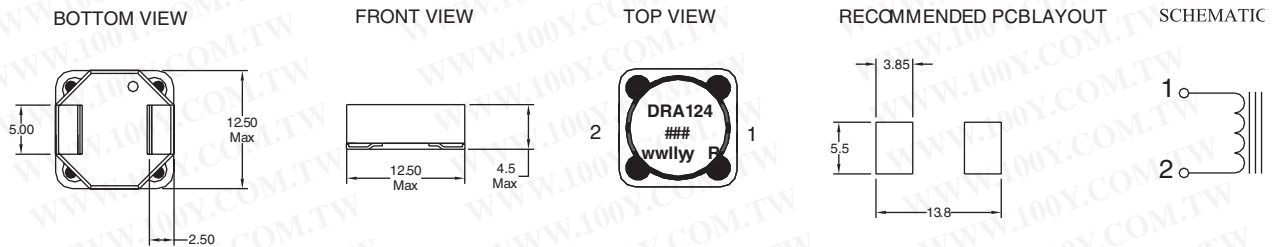

**DRA125 Series**

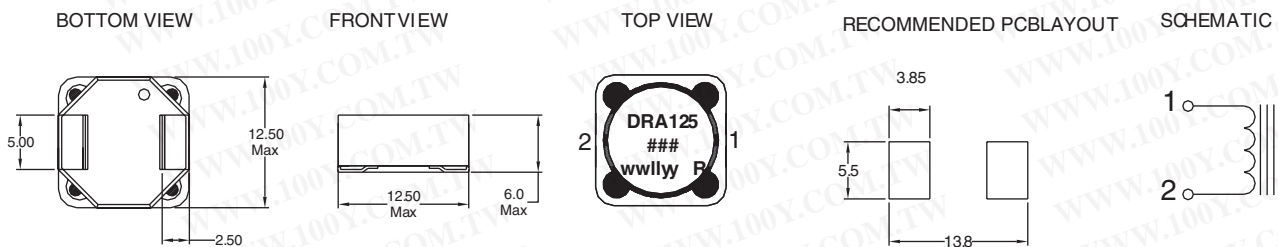

**DRA127 Series**

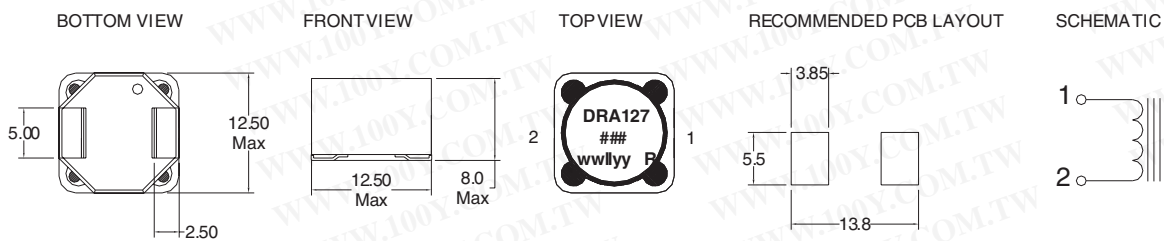

Dimensions in Millimeters.

### = Inductance value in uH. R = decimal point.  
 If no R is present third character = # of zeros  
 wwlyy = (date code) R = revision level

**Packaging Information**

**DRA73 Series**

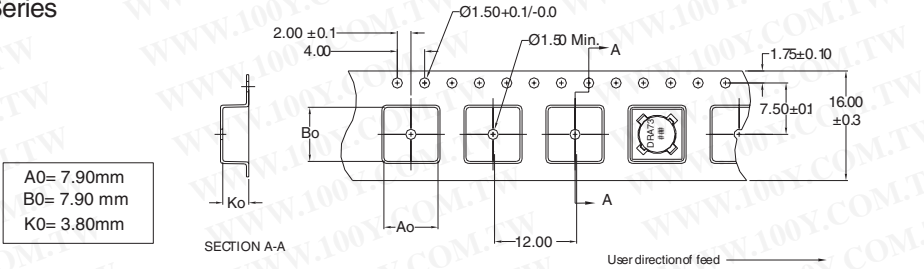

Parts packaged on 13" Diameter reel,  
 1,350 parts per reel.

**DRA74 Series**

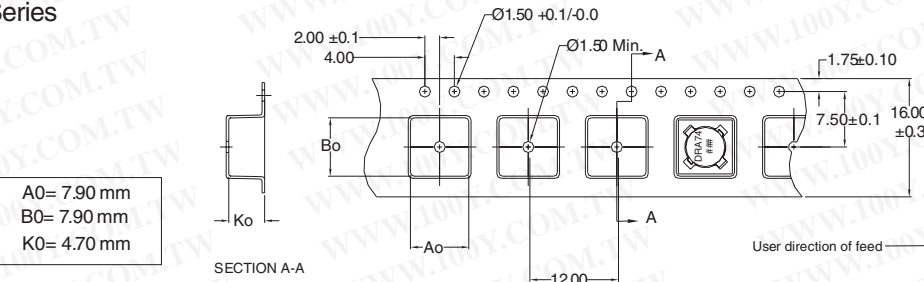

Parts packaged on 13" Diameter reel,  
 1,100 parts per reel.

**DRA124 Series**

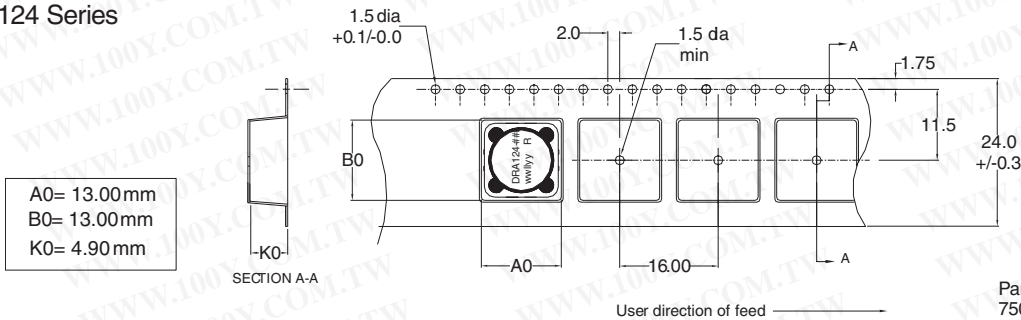

Parts packaged on 13" Diameter reel,  
 750 parts per reel.

**DRA125 Series**

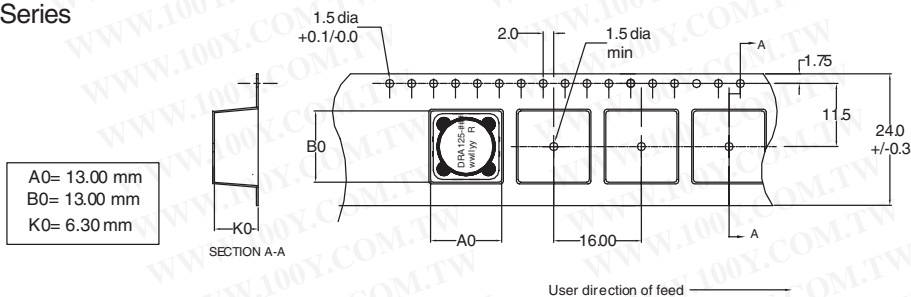

Parts packaged on 13" Diameter reel,  
 600 parts per reel.

**DRA127 Series**

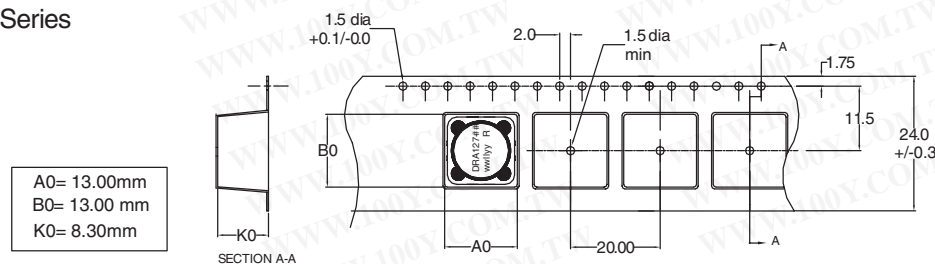

Parts packaged on 13" Diameter reel,  
 350 parts per reel.

**Temperature Rise vs. Watt Loss**

DRA 73 series

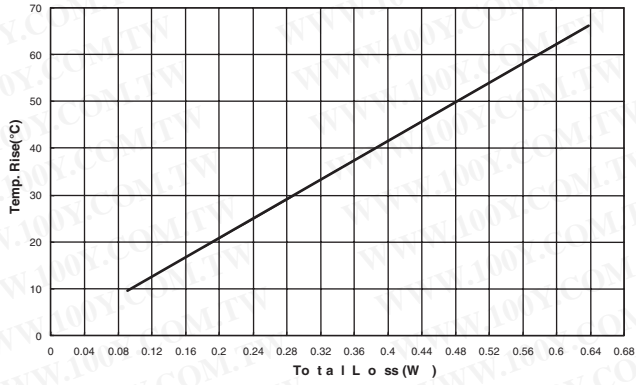

DRA 74 series

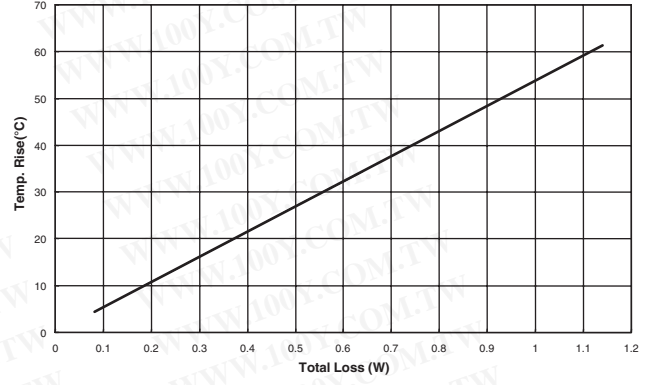

DRA 124 series

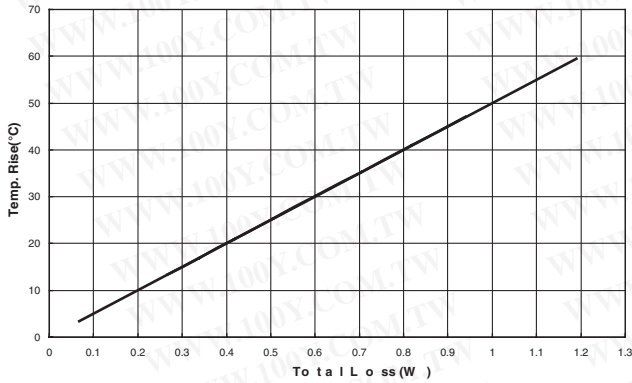

DRA 125 series

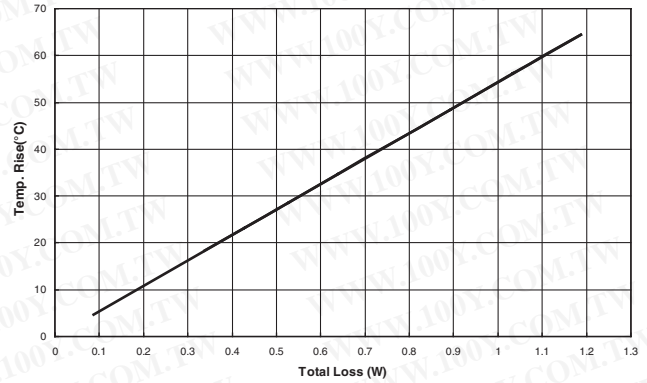

DRA 127 series

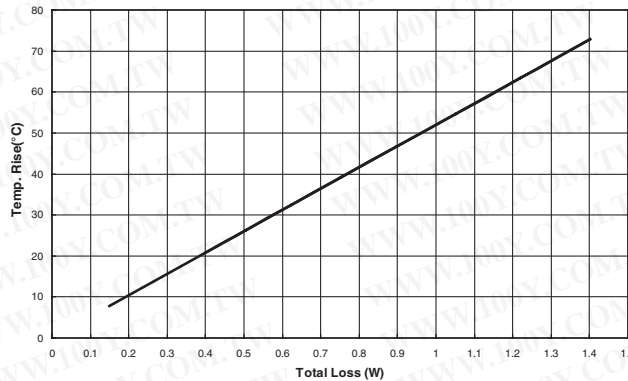

**Inductance Characteristics**

OCL vs Isat/DRA 73 series

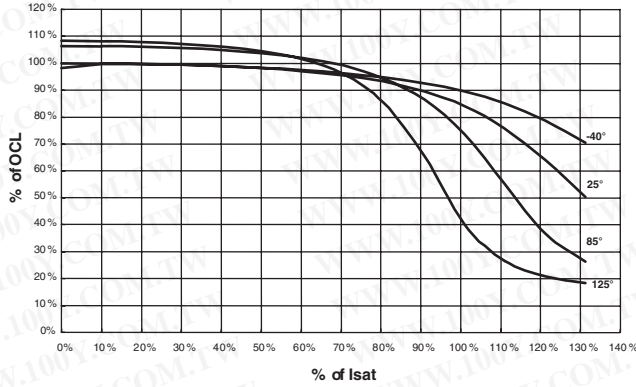

OCL vs Isat/DRA 74 series

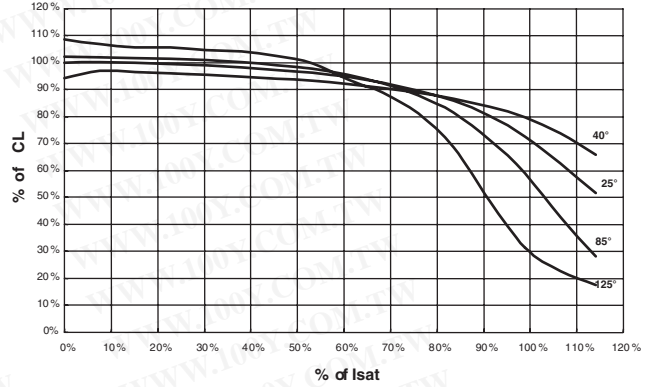

OCL vs Isat/DRA 124 series

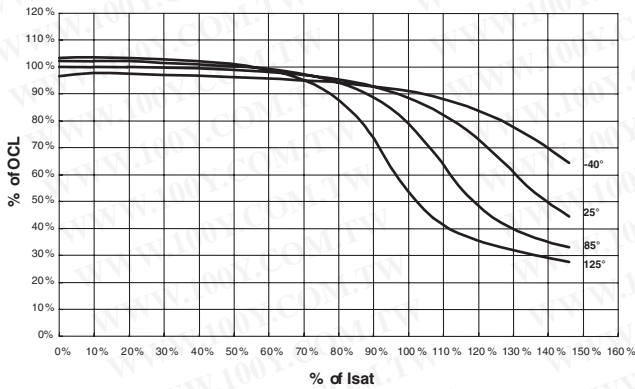

OCL vs Isat/DRA 125 series

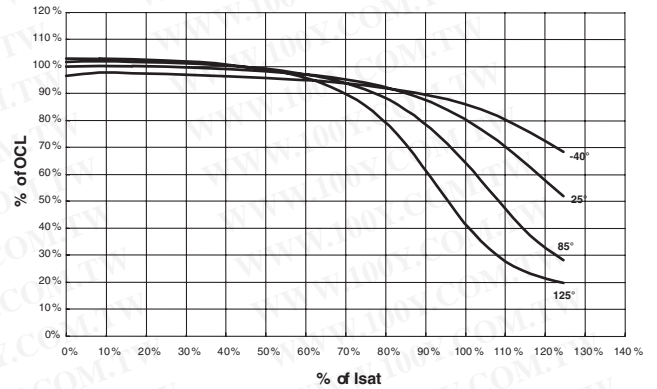

OCL vs Isat/DRA 127 series

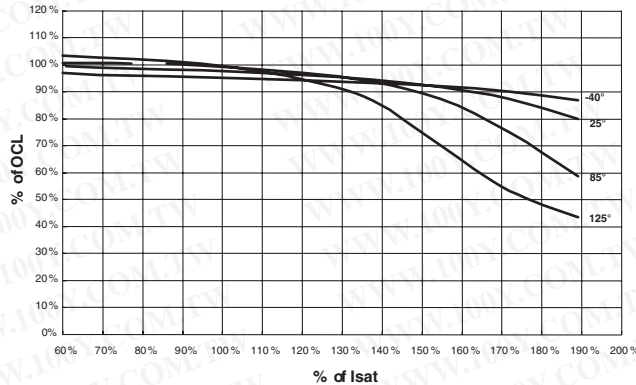

**Inductance Characteristics**

DRA 73 series

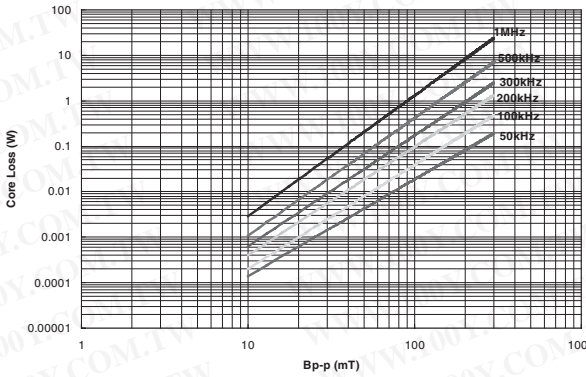

DRA 74 series

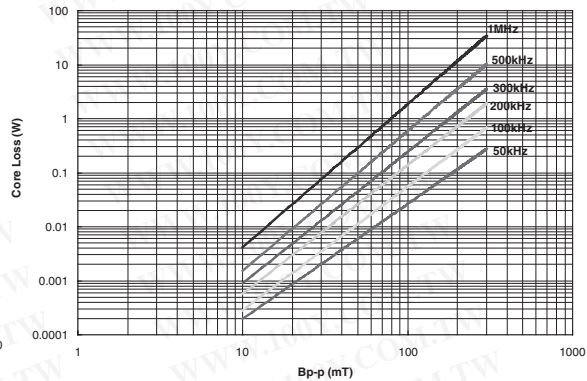

DRA 124 series

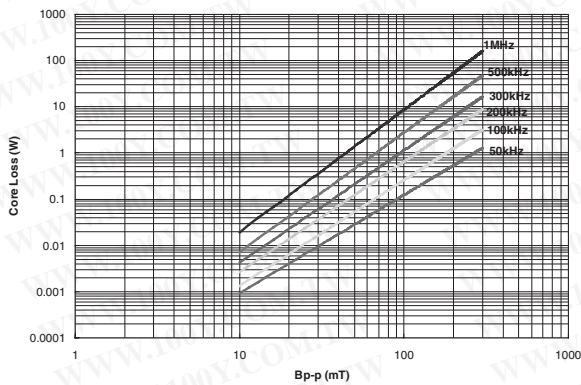

DRA 125 series

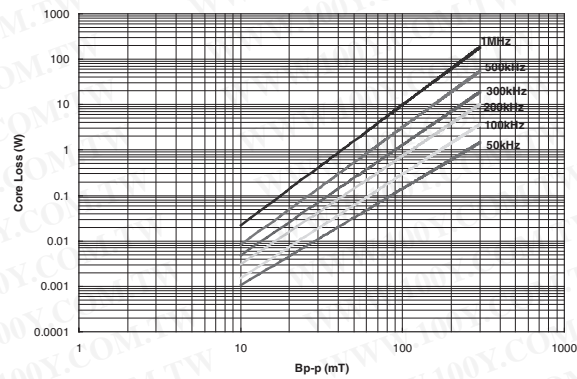

DRA 127 series

