

International **IOR** Rectifier

47CTQ020
 47CTQ020S
 47CTQ020-1

SCHOTTKY RECTIFIER

40 Amp

Major Ratings and Characteristics

Characteristics	Values	Units
$I_{F(AV)}$ Rectangular waveform	40	A
V_{RRM}	20	V
I_{FSM} @ tp=5 μ s sine	1000	A
V_F @20Apk, $T_J=125^\circ\text{C}$	0.34	V
T_J	-55to 150	$^\circ\text{C}$

Description/Features

This center tap Schottky rectifier has been optimized for ultra low forward voltage drop specifically for 3.3V output power supplies. The proprietary barrier technology allows for reliable operation up to 150 $^\circ\text{C}$ junction temperature. Typical applications are in parallel switching power supplies, converters, reverse battery protection, and redundant power subsystems.

- 150 $^\circ\text{C}$ T_J operation
- Center tap configuration
- Optimized for 3.3V application
- Ultra low forward voltage drop
- High frequency operation
- Guard ring for enhanced ruggedness and long term reliability
- High purity, high temperature epoxy encapsulation for enhanced mechanical strength and moisture resistance

Case Styles		
<p>47CTQ020</p>  <p>TO-220</p>	<p>47CTQ020S</p>  <p>D²PAK</p>	<p>47CTQ020-1</p>  <p>TO-262</p>

Voltage Ratings

Part number	47CTQ020, ..020S, ..020-1		
V_R Max. DC Reverse Voltage (V)	@ 125° C	20	
V_R Max. DC Reverse Voltage (V)	@ 150° C	10	

Absolute Maximum Ratings

Parameters	47CTQ	Units	Conditions
$I_{F(AV)}$ Max. Average Forward Current (Per Device) (Per Leg)	40 20	A	50% duty cycle @ $T_C = 135^\circ\text{C}$, rectangular wave form
I_{FSM} Max. Peak One Cycle Non-Repetitive Surge Current (Per Leg)	1000 250	A	5 μs Sine or 3 μs Rect. pulse 10ms Sine or 6ms Rect. pulse Following any rated load condition and with rated V_{RRM} applied
E_{AS} Non-Repetitive Avalanche Energy (Per Leg)	18	mJ	$T_J = 25^\circ\text{C}$, $I_{AS} = 3$ Amps, $L = 3$ mH
I_{AR} Repetitive Avalanche Current (Per Leg)	3	A	Current decaying linearly to zero in 1 μsec Frequency limited by T_J max. $V_A = 1.5 \times V_R$ typical

Electrical Specifications

Parameters	47CTQ	Units	Conditions
V_{FM} Max. Forward Voltage Drop (Per Leg) (1)	0.45	V	@ 20A $T_J = 25^\circ\text{C}$
	0.51	V	@ 40A
	0.34	V	@ 20A $T_J = 125^\circ\text{C}$
	0.44	V	@ 40A
	0.31	V	@ 20A $T_J = 150^\circ\text{C}$
	0.42	V	@ 40A
I_{RM} Max. Reverse Leakage Current (Per Leg) (1)	3	mA	$T_J = 25^\circ\text{C}$ $V_R = \text{rated } V_R$
	310	mA	$T_J = 125^\circ\text{C}$
	60	mA	$T_J = 125^\circ\text{C}$ $V_R = 5V$
	45	mA	$T_J = 125^\circ\text{C}$ $V_R = 3.3V$
	306	mA	$T_J = 150^\circ\text{C}$ $V_R = 10V$
$V_{F(TO)}$ Threshold Voltage	0.188	V	$T_J = T_J$ max.
r_t Forward Slope Resistance	5.9	m Ω	
C_T Max. Junction Capacitance (Per Leg)	3000	pF	$V_R = 5V_{DC}$, (test signal range 100Khz to 1Mhz) 25°C
L_S Typical Series Inductance (Per Leg)	5.5	nH	Measured lead to lead 5mm from package body
dv/dt Max. Voltage Rate of Change (Rated V_R)	10,000	V/ μs	

Thermal-Mechanical Specifications

(1) Pulse Width < 300 μs , Duty Cycle < 2%

Parameters	47CTQ	Units	Conditions
T_J Max. Junction Temperature Range	-55 to 150	$^\circ\text{C}$	
T_{stg} Max. Storage Temperature Range	-55 to 150	$^\circ\text{C}$	
R_{thJC} Max. Thermal Resistance Junction to Case (Per Leg)	1.5	$^\circ\text{C}/\text{W}$	DC operation
R_{thJC} Max. Thermal Resistance Junction to Case (Per Package)	0.75	$^\circ\text{C}/\text{W}$	DC operation
R_{thCS} Typical Thermal Resistance, Case to Heatsink	0.50	$^\circ\text{C}/\text{W}$	Mounting surface, smooth and greased (only for TO-220)
wt Approximate Weight	2(0.07)	g(oz.)	
T Mounting Torque	Min.	6(5)	Kg-cm (lbf-in)
	Max.	12(10)	

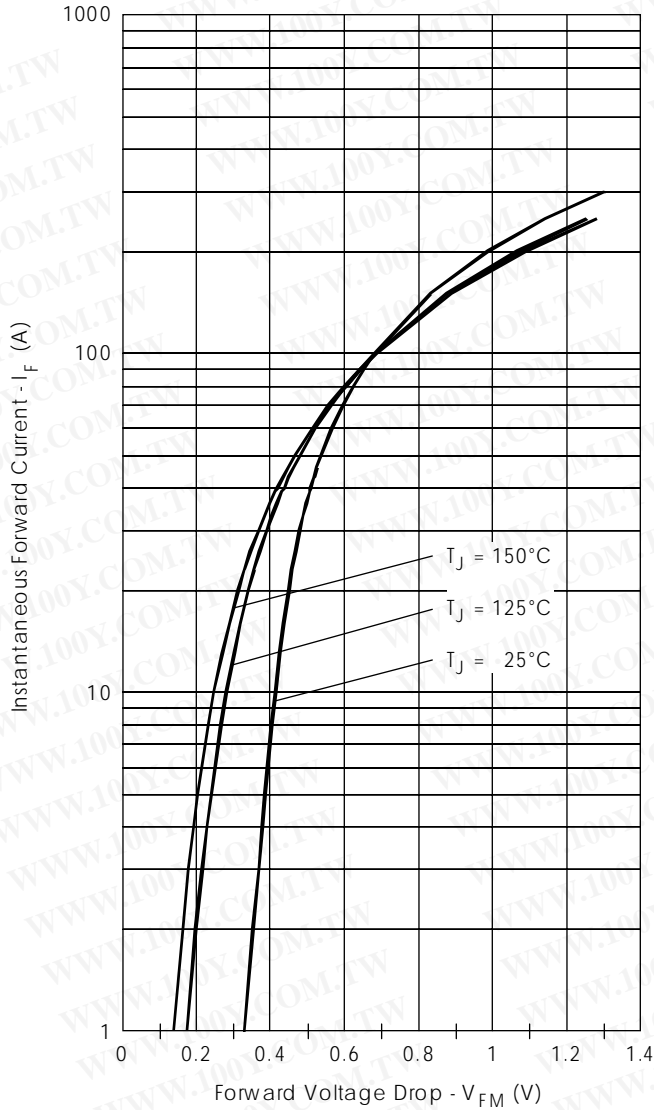

Fig. 1 - Max. Forward Voltage Drop Characteristics (Per Leg)

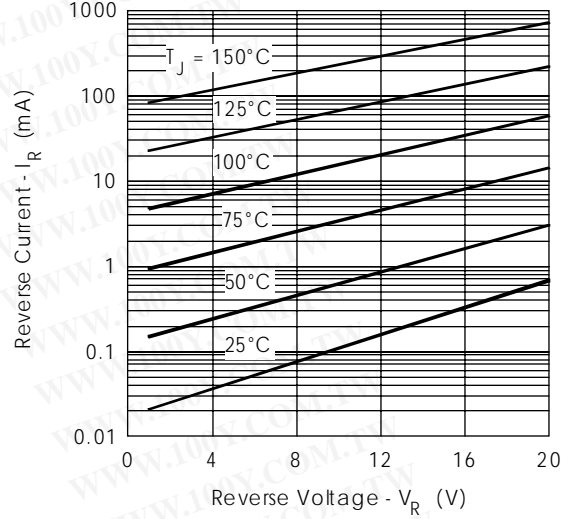

Fig. 2 - Typical Values Of Reverse Current Vs. Reverse Voltage (Per Leg)

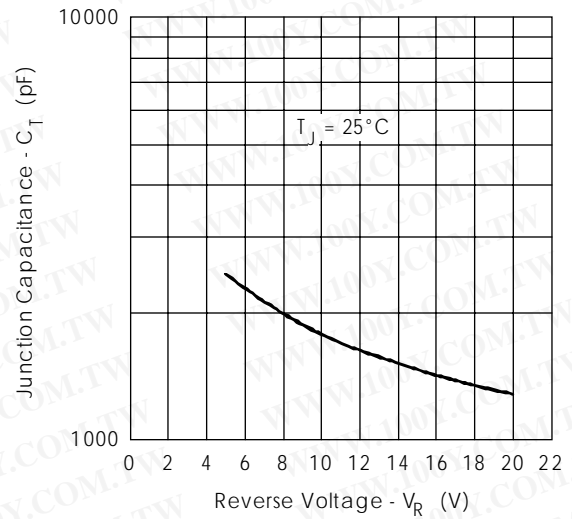

Fig. 3 - Typical Junction Capacitance Vs. Reverse Voltage (Per Leg)

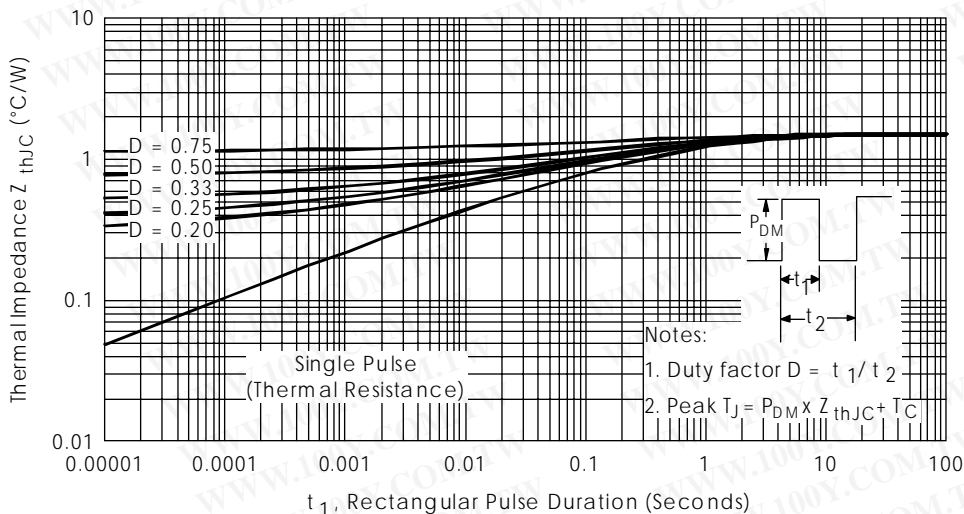

Fig. 4 - Max. Thermal Impedance Z_{thJC} Characteristics (Per Leg)

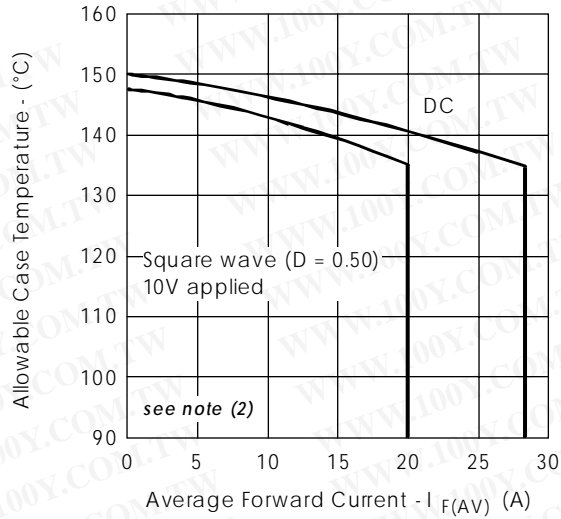

Fig. 5 - Max. Allowable Case Temperature Vs. Average Forward Current (Per Leg)

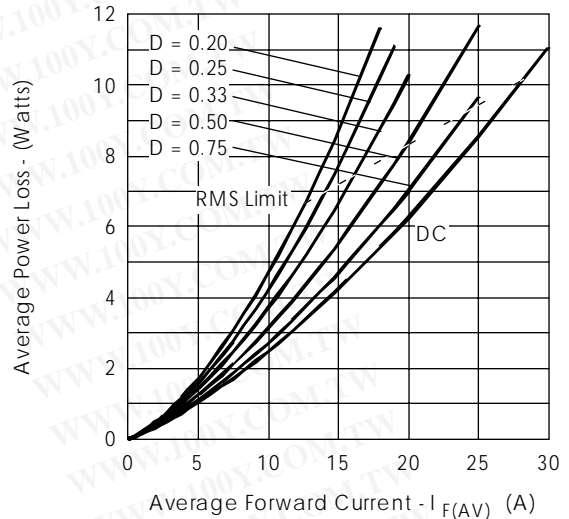

Fig. 6 - Forward Power Loss Characteristics (Per Leg)

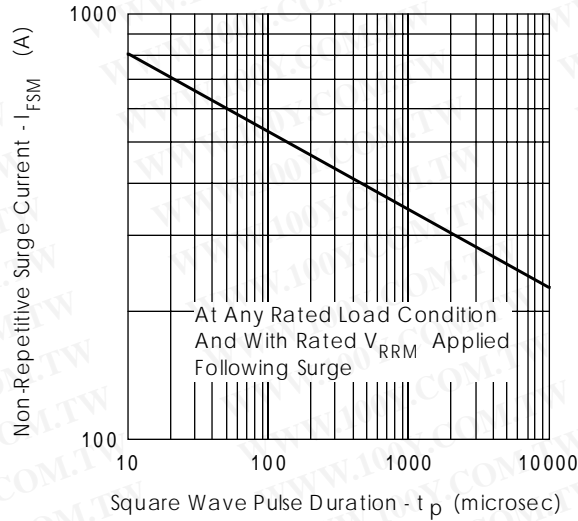

Fig. 7 - Max. Non-Repetitive Surge Current (Per Leg)

勝特力材料 886-3-5753170
 勝特力电子(上海) 86-21-54151736
 勝特力电子(深圳) 86-755-83298787
[Http://www.100y.com.tw](http://www.100y.com.tw)

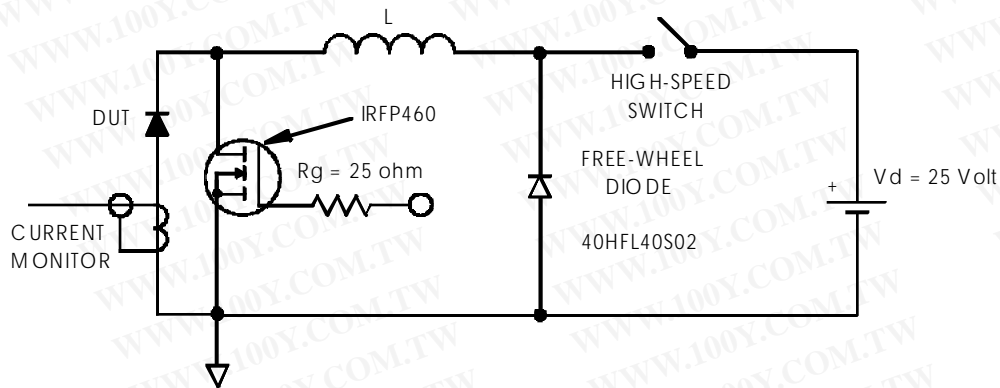

Fig. 8 - Unclamped Inductive Test Circuit

- (2) Formula used: $T_C = T_J - (P_d + P_{d_{REV}}) \times R_{thJC}$;
 $P_d = \text{Forward Power Loss} = I_{F(AV)} \times V_{FM} @ (I_{F(AV)} / D)$ (see Fig. 6);
 $P_{d_{REV}} = \text{Inverse Power Loss} = V_{R1} \times I_R (1 - D)$; $I_R @ V_{R1} = 10 \text{ V}$

Ordering Information Table

Device Code

47	C	T	Q	020	-1
1	2	3	4	5	6

- 1** - Essential Part Number
- 2** - C = Common Cathode
- 3** - T = TO-220
- 4** - Q = Schottky Q Series
- 5** - Voltage Rating 020 = 20V
- 6** - -1 = TO-262
S = D²Pak

勝特力材料 886-3-5753170
胜特力电子(上海) 86-21-54151736
胜特力电子(深圳) 86-755-83298787
[Http://www.100y.com.tw](http://www.100y.com.tw)

Outline Table

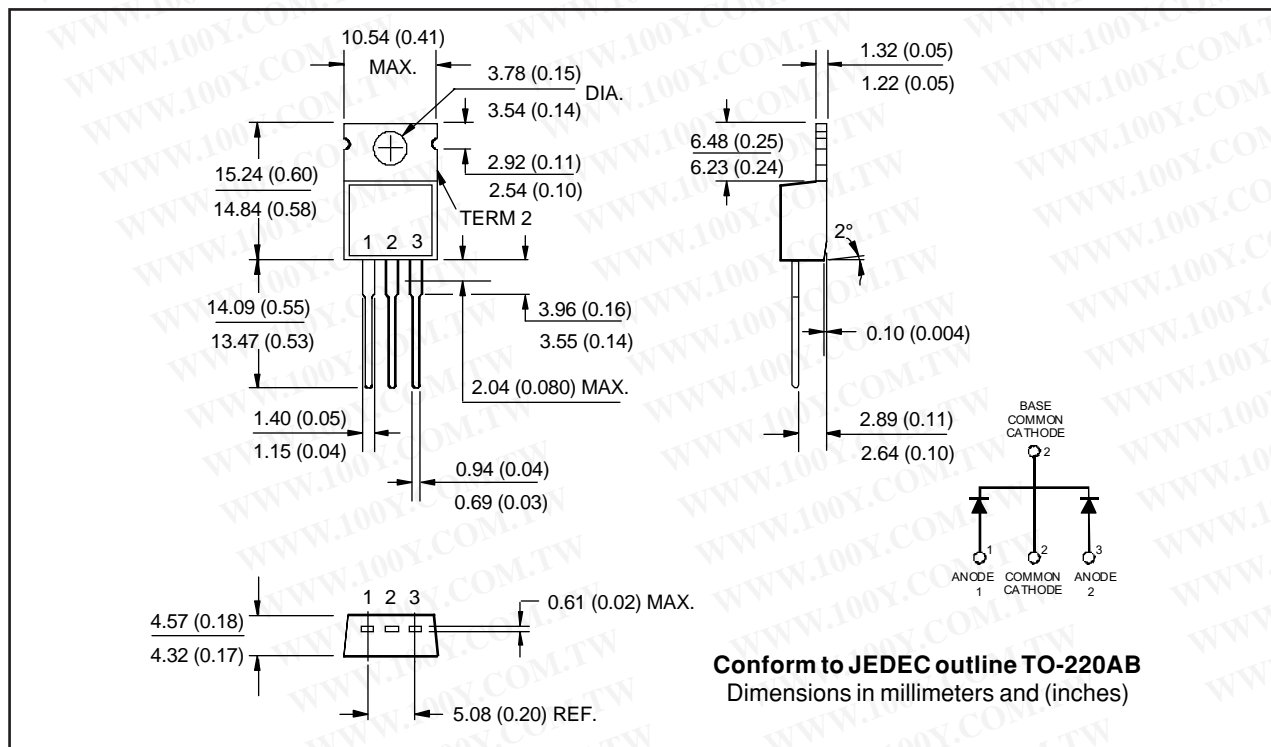

Outline Table

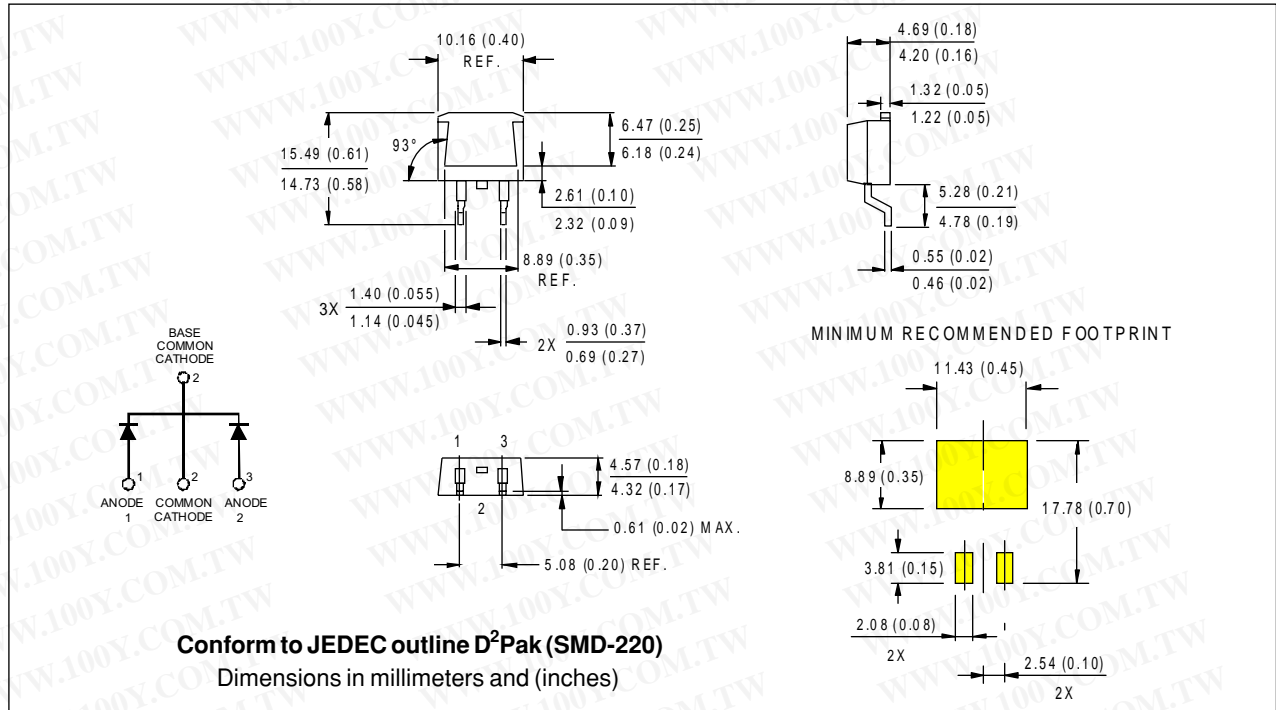

Tape & Reel Information

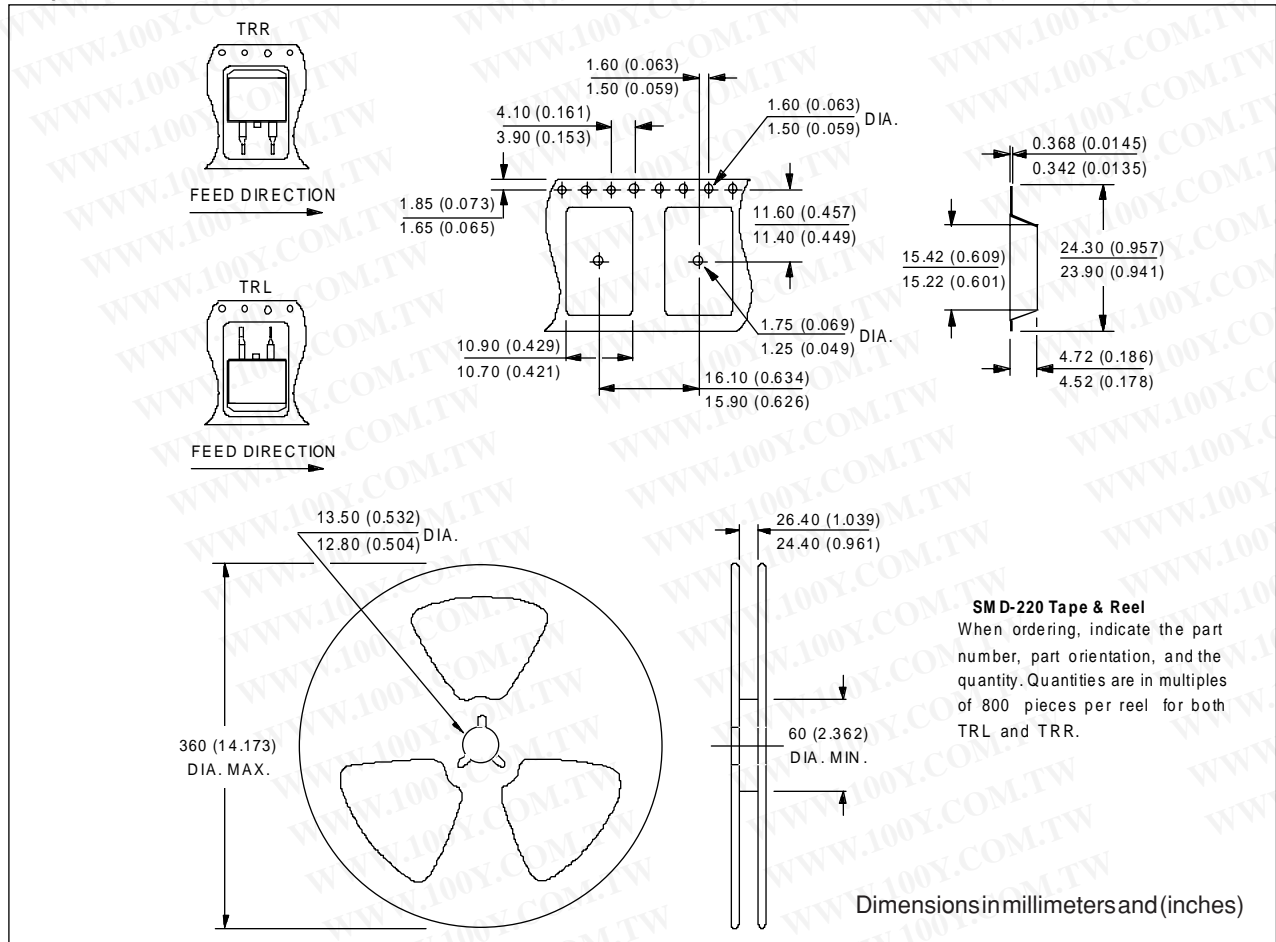

Outline Table

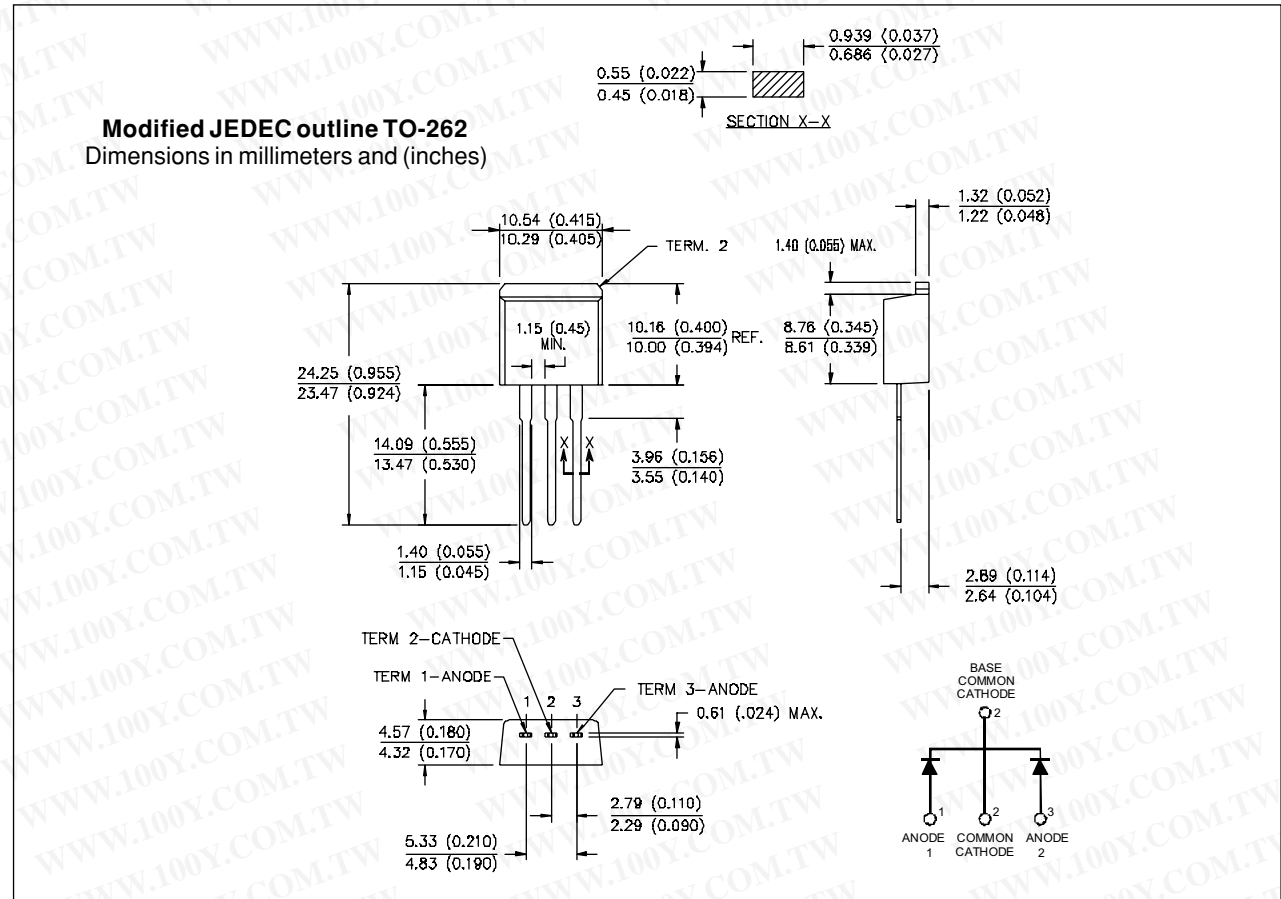

勝特力材料 886-3-5753170
 勝特力电子(上海) 86-21-54151736
 勝特力电子(深圳) 86-755-83298787
[Http://www.100y.com.tw](http://www.100y.com.tw)