

JBC

勝特力材料 886-3-5753170
勝特力电子(上海) 86-21-34970699
勝特力电子(深圳) 86-755-83298787
[Http://www.100y.com.tw](http://www.100y.com.tw)



CATALOGUE ADVANCED 11.2

THE POWER
OF EXPERIENCE



ESD safe

All JBC products comply with EC regulations,
and the ESD recommendations.



More than 80 years of experience have placed JBC at the technological forefront of tools for soldering and rework operations in electronics.

Innovation, efficiency and reliability are the key features of a wide range of products which have been designed to satisfy the most demanding requirements of professionals.

HIGH TECHNOLOGY, SUPERIOR QUALITY.

Making the products perfect is one of the main objectives of JBC's improvement and development program. The R&D department has created the most innovative soldering technologies, which JBC is proud to present in this catalog.

All JBC products comply with EC regulations and ESD recommendations.

A GLOBAL ORGANIZATION AT YOUR SERVICE.

JBC's global organization of local offices and a distributor network spanning 5 continents puts at your disposal a solid commercial organization that guarantees quick and efficient service.



ADVANCED Series

The key to successful handsoldering in the LEAD FREE era

As soldering has become more demanding due to the use of lead-free alloys and increased complexity and thermal characteristics of PCBs, the need for tools with outstanding specifications is more than evident.

With a unique heating system, controlled by microprocessors, an exceptional heat recovery is achieved which enables to work at lower temperatures, while at the same time increasing the quality and reliability of solder joints by 80%.

JBC has revolutionized the soldering process by offering higher reliability and cleaner solder joints.

JBC tools solder efficiently at 350 degrees (662 F) – no tool from any competitor achieves the same!

By controlling the heat, we improve quality.

JBC's technology exceeds the performance of the best tools in the market by 80%. Refer to the graphs below which show the results of empirical tests.

A/ TIME TO REACH 350° C

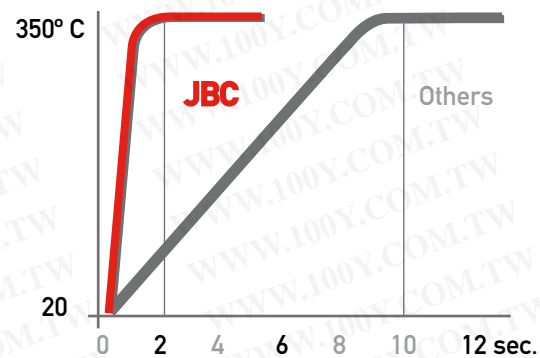

Graph A shows responsiveness of a standard station compared to a JBC station. A standard station needs between 10 and 90 seconds to reach 350° C, while any JBC station equipped with a T210 hand-piece reaches the same temperature in only 2 seconds. The superior responsiveness of the JBC system could not be clearer.

We invite you to discover the outstanding performance of JBC tools.

We have demo stations at your disposal, contact us!

B/ PROCESS FOR 3 SOLDER JOINTS

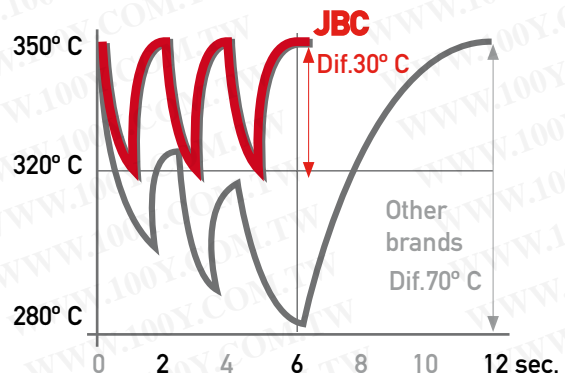

Graph B shows responsiveness on soldering of 3 joints. Lack of thermal response of the standard tool results in a temperature drop of 70° C versus only 30° C of a JBC tool. The difference grows even bigger for more demanding soldering applications.



A new and revolutionary technology

JBC's exclusive heating system generates high power with a small-size heater.

The result is both a minimum of heated mass and a minimum of thermal inertia. For optimum performance concerning immediate temperature recovery, maximum power supply and minimum temperature fluctuations, the heating system features an extremely sensitive temperature sensor integrated in the resistor.

ERGONOMICS AND USABILITY:

JBC soldering irons are currently the lightest, smallest and most ergonomic handpieces available in the market. The short tip-to-handle distance benefits a higher and more accurate work performance.

LOW OWNERSHIP COSTS CARTRIDGES LAST UP TO FIVE TIMES LONGER:

On leaving the soldering iron on the stand, the temperature of the tip automatically drops to 220° C; the temperature is back to work level immediately after taking the soldering iron from the stand. This 'stand-by' temperature drop significantly reduces wear of the tip, resulting in extended life up to 5 times longer than that of conventional non-JBC tips.

LOW-TEMPERATURE SOLDERING FOR LEAD-FREE SOLDERING

JBC systems allow soldering at 380° C instead of 450° C thanks to its highly efficient temperature recovery system. This system eliminates the risk of damaging components by applying excessive heat and therefore optimizes the quality of your operations.



Two soldering irons in one: Adaptability to different types of jobs

Thanks to the cartridge extractor system in the stand and the temperature recovery system, it was never so easy to change cartridges without interrupting your work. A single handpiece enables you to operate with various cartridges.



Pull slightly to remove the cartridge.

Push gently and place a new one.

EASY CALIBRATION

Control of the JBC system by using microprocessors makes frequent recalibration of the stations unnecessary. If still required, soldering tips can be easily calibrated by using JBC's TI-A thermometer; any other adjustment can be made via the menu of the station.



DS Micro desoldering iron



AP Solder feed iron



T210 Handpiece



T245 Handpiece



PA Micro hot tweezers



COMPACT line Stations



CONCENTRATED REWORK POWER

JBC offers two lines of soldering stations, each designed to work with a dedicated tool. A stand incorporated in the housing of the control unit offers a safe place to put down the handpiece.

Each station has been designed for work with a designated tool.

The integrated, intelligent sleep and hibernation features combine perfectly with the fastest temperature recovery system available in the market.

PROCESS CONTROL

Set temperature limits, check usage counters, lock the station with a PIN, or program sleep and hibernation modes.

Depending on your requirements you can save up to 3 different temperature settings; changing from one saved temperature setting to the next will always increase or decrease the temperature level to the next of all saved temperatures.

The stations are operational regardless if saved temperature settings are activated or not.

INTELLIGENT HEAT MANAGEMENT

The only time a soldering iron must reach its required temperature level is during a soldering operation. JBC's intelligent heat management detects how the tools are used; accordingly the integrated support function activates the sleep or hibernation mode. The intelligent heat management helps to extend tip life by lowering temperature; it also helps to save energy by reducing power usage to 10W in sleep mode and 4W in hibernation mode.

Help us to protect the environment and to save energy!

QUICK TIP CHANGER

No tools or pads are needed to change a cartridge. Simply place the tip in the extractor of the stand, remove one cartridge and insert another one. Reduce idle time while increasing operator safety.

COMPACT line Soldering and desoldering stations

This product range features 4 stations, each designed work to with one dedicated tool. The corresponding stands are incorporated in the same housing as the control unit for easy handling.

Cartridge extractor: An easily accesible location of the extractor for rapid cartridge change.

Adjustable stand: Fast and simple adjustment of the angle of the stand without requiring additional tools.

Cable collector: Maintains working area free of cable.

Brass wool housing: Contains metal wool and minimises splashing of solder particles.

Each station works with its designated tool.

The intelligent sleep and hibernation functions, which help to extend tip life and to save energy, are combined with extremely fast temperature recovery unrivalled in the market.

Tip wiper: Tapping and wiping: Very soft and temperature resistant receptacle allows tapping and wiping of the tip to eliminate excess solder.

Sponge: For final cleaning.

OPTIONAL

Metal brushes for more aggressive cleaning.
Retinner chemical cleaning system.



COMPACT line Soldering and desoldering stations

CD Soldering 120V

The CD soldering control units feature large back-lit graphic displays that show important information at a glance. Any changes to the original setting can be easily made via menu on the display. All settings can be locked by PIN.

Basic specifications

Nominal power: 75W
Peak power: 140W
Temperature range: 90-450° C

CD-1BB Soldering station 120V

General electronics jobs.

Included Control unit CD
Handpiece T245-A
Cartridges C245-003 & C245-007

CD-1SB Soldering station 120V

For high precision solder joints.

Included Control unit CD
Handpiece T210-A
Cartridges C210-001 & C210-008

CF-1B Solder feed Station 120V

Designed for repetitive soldering or when you need a free hand. Equipped with solder feed iron of 1mm diameter.

Basic specifications

Nominal power: 75W
Peak power: 140W
Temperature range: 90-450° C

Included CF control unit
AP-A Solder feed iron.
C130-403 cartridge.



CP-1B Micro tweezers Station 120V

For soldering and desoldering SMD components with Micro-Tweezers.

Basic specifications

Nominal power: 2 x 20W
Peak power: 2 x 40W
Temperature range: 90-450° C

Included Control unit CP
PA-A micro hot tweezers
2 X C120-002 cartridge.



CS/CV Micro tweezers Station 120V

Desoldering stations with electric or pneumatic suction systems.

Basic specifications

Nominal power: 20 W
Peak power: 30 W
Temperature range: 300-450° C

CS-1B Electric system 120V

Included Control unit CS
DS-A Micro desoldering iron with tip C360-004
MS-A Electric vacuum pump.

CV-1B Pneumatic system 120V

Included Control unit CV
DS-A Micro desoldering iron with tip C36-004
MV-A Pneumatic suction system
fed by compressed air max. 6 bar.



MS or MV
Suction module for
desoldering iron

DI, DD, DM
control units
for 1, 2 and 4 tools

JT or TE
High power hot air station



PA

MODULAR line



Stands



T245

T210

The JBC Modular Line features 4 control units, 6 stands, 8 tools, and more than 300 cartridges and tips adaptable for the tools.

All components can be freely combined for maximum personalized set-up.

For example, the 4-tools DM station allows to connect 2 soldering irons, 1 pair of tweezers and 1 desoldering iron. Combine this set-up with a JT hot air station and you will have a complete set of tools capable of almost any type of electronics repair.

Following the above example, combine our 2-tools DD station with any other station.

JBC's DI, DD and DM stations offer full connectivity to any kind of tools like soldering irons, desoldering irons and tweezers.

Minimum requirements for a functioning soldering station are a control unit, a stand, 1 tool and 1 cartridge.

DI-1B 1 Tool control unit

The DI-1B 1-tool digital control unit features a digital read-out display for accurate temperature and tool control.

This control unit was designed for production and rework applications for low to medium thermal requirements.

The control unit features adjustable sleep and hibernation modes, as well as adjustable temperature settings. All values

can be locked by PIN.

All JBC tools are fully connectable to all control units (use corresponding stands for tools), including DR and DS desoldering irons in combination with either of JBC's electric suction systems MS-A and MV-A.

DI-1B 1 tool control unit 120V

Basic specifications

Nominal power: 75 W
Peak power: 140 W
Sleep power: 10W
Hibernation power: 4W
Temperature selection: 90-450 °C
Weight: 2 kg

For a complete soldering station the following is needed:

Control unit
One tool with corresponding stand & cartridge.



DD and DM 2- & 4-Tools digital control units

The DD and DM 2 & 4 Tools digital control units feature a digital read-out display for accurate temperature and tool control.

The DD-1B 2-tools control unit offers connectivity for working with 2 tools simultaneously.

The DM-1B 4 tools control unit offers connectivity for working with 4 tools simultaneously.

These control units were designed for production and rework applications with high thermal requirements.

The control units feature adjustable sleep and hibernation modes, as well as independently adjustable temperature settings for each individual tool. All values can be locked by PIN.

DD and DM control units are fully connectable to all JBC tools (use corresponding stands for tools), including DR and DS desoldering irons in combination with either of JBC's electric suction systems MS-A and MV-A.

DD-1B 2 tools control unit 120V

Basic specifications

Nominal power: 2 X 75 W
Total peak power :2 X 140 W
Sleep power: 2 X 10W
Hibernation power: 2 X 4W
Temperature selection: 90-450° C
Weight: 3,5 kg

DM-1B 4 tools control unit 120V

Basic specifications

Nominal power: 4 X 75 W
Total peak power: 4 X 140 W
Sleep power: 4 X 10W
Hibernation power: 4 X 4W
Temperature selection: 90-450° C
Weight: 4,5 kg

For a complete soldering station the following is needed:

Control unit
From 1 to 4 tools with its corresponding stand & cartridge



MS-A and MV-A Desoldering suction modules

MS-A and MV-A desoldering suction modules are indispensable for a complete desoldering process. The control unit regulates the temperature, while the suction module sucks

in the solder. The suction modules line-up features one electric model regulated by the control unit, and one pneumatic model powered by compressed air.

MS-A Electric suction module

Electric suction module with overdrive startup function that offers quick collection of solder before it cools down. This suction system is regulated by the control unit.

Basic specifications

Power: 12 W
Supply: 24 V
Weight: 1,7 Kg

MV-A Pneumatic suction module

This pneumatic suction module uses compressed air and a Venturi valve. This system offers outstanding desoldering results because of its immediate suction responsiveness. This suction system is powered by compressed unit.

Basic specifications

Power: 3 W
Supply: 24 V
Recommended air pressure: 5 Bar (max. 6)
Weight: 1,4 Kg



Tip cleaning stand

JBC introduces different methods for cleaning tips, designed for removal of oxidation, of residues of flux etc.

With the implementation of lead-free soldering it has become necessary to use methods to clean tips other than with a simple wet sponge. The wet sponge can be replaced by dry cleaning methods like metal wool or metal brushes.

Of all cleaning methods the sponge is the softest, whereas the brush is the most aggressive. Use of either depends on how much residue needs to be removed, which in turn is a result of work temperature and type of solder used.

CL9885 Tip cleaning stand



CL6210 Brass wool

CL0236 Tip wiper

CL9885 Tip cleaning stand

Tip cleaning stand is designed to be able to be used iright next to the point of work.

By his weight and nonskid feet it is totally self-lifting, being able to use without needing holding the support with the hand or having to fix it during the cleaning of the tips.



Hood: Contains metal wool and minimises splashing of solder particles.

CL6210 Brass wool

Very effective cleaning method. Leaves a small layer of solder on the tip preventing oxidation between cleaning and rewetting.



CL0236 Tip wiper

Tapping and wiping: Very soft and temperature resistant receptacle allows tapping and wiping of the tip to eliminate the excess of solder.



S0354 Sponge

To help the final cleaning.

OPTIONAL CLEANING TIPS

CL6205 Inox wool



CL6220 Brushes

For more indepth cleaning of the tips, tweezers & desoldering rons.



TT-A Tip tinner

Chemical system to clean and retin the tip at the same time.



Stands

JBC's stands feature a line-up covering the variety of JBC's Advanced Series tools. The stands are placed between the control unit and the tool for optimum performance, like temperature reduction in sleep mode when the tool is placed in the stand for extended tip-life and less oxidation.

The cartridge extractor system featured in the stands AD-SB and DN-SB offers switching cartridges without the need to interrupt your work.

All stands can be connected to all Modular line stations.

AD-SB

For T210-A handpiece
For T245-A handpiece

Includes

3 cartridges extractor magazine
for C210 or C245
Quick cartridges change
Sleep mode

AP-SB

For AP-A Solder feed iron

Includes

Sleep mode

HT-SB

For HT-A hot tweezers

Includes

Sleep mode

PA-SB

For PA-A Micro hot tweezers

Includes

Sleep mode

DR-SB

For DR-A desoldering iron

Includes

Sleep mode

DS-SB

For DS-A micro
desoldering iron

Includes

Sleep mode

A1286 Kit extension lead for stand

For increased distance between stand and control unit. Includes a cable of 1.5 m length with corresponding connectors on each side.

A1287 Extension accessory for the desoldering silicon tube

Extension accessory for desoldering iron. Includes a cable of 1.5 m length.

SC-A Cartridges stand

Stand for removal and insertion of up to 12 cartridges of the C245 cartridges range.

Offers perfect view for quick selection of cartridges.



Tools

NANO Tools

The smallest soldering tools available in the market, designed for the smallest SMD components like chips 0201 and smaller. Perfect for work with magnifier thanks to easy handling and low weight. Cartridges are interchangeable as all others from the Advanced range, and are capable of giving out 15W of power, in spite of its reduced size.

NP105-A Nano Hot Tweezers

Uses cartridges C105

Perfect for soldering and desoldering very small-sized chip components.



NT205-A Nano soldering iron

Uses cartridges C105

For high-precision soldering jobs



T210-A Micro Handpiece

For high-precision applications.

Used with C210 cartridges.

Offers quick cartridge change.

Fume extractor

F3450 For T210-A handpieces



Tools

T245 Handpieces

For general soldering jobs in electronics
Used with C245 cartridges.

T245-A

Offers quick cartridge change.

Fume extractor

F3449 For T245-A handpieces

F6457 For Comfort T245-TA handpieces



Real Size.

T245 Comfort handpieces

T245-TA

Handpiece incorporates a screw that allows to fix the cartridges,
Ideal for high intensity jobs where NO cartridge change is needed.

T245-SA

A screw in this handpiece helps to securely fix the cartridge, ideal
for extensive soldering jobs that do NOT require frequent cartridge
changes. Supplied with a cable of 3 m length.



Real Size.

T245 Nitrogen handpieces

T245-NA

For nitrogen soldering jobs.
Handpiece incorporates a screw that allows to fix the cartridges.



Real Size.

Tools

PA-A Microtweezers

The PA-A micro-tweezers are designed for soldering and desoldering SMD micro components.

Each cartridge is individually controlled by the control unit, guaranteeing fast heating-up, accuracy and recovery of temperature.

The available range of cartridges is made for desoldering a wide range of components.

The PA-A micro-tweezers connect to JBC stations DI, DD, DM, AM and Single line AP.

Weight of PA-A micro-tweezers without cartridges 102 g.
Supplied without cartridges.



HT-A Tweezers

The HT-A tweezers are designed specifically for soldering and desoldering small and medium-sized SMD components. A cable strip cartridge is also available.

Each cartridge is individually controlled by the control unit, guaranteeing fast heating-up, accuracy and recovery of temperature.

The HT-A tweezers connect to JBC station DI, DD, DM, AM and Single line AP.

Weight of HT-A tweezers without cartridges 102 g.



Tools

DS-A Microdesoldering iron

The DS-A micro desoldering iron adapts to the ever-decreasing size of new components.

Very easy cleaning and maintenance. Tips are easily inserted by gentle pushing.

The iron connects to JBC stations DS-1A, DV-1A, DI, DD, DM, AM and Single line AP.

Weight of DS-A micro desoldering iron 176 gr.
Supplied with tip C360-004.



Desoldering tip

Desoldering body with heater

DS-A Desoldering



Disposable carton tube

Exchangeable filter set



Tools

DR Desoldering iron

Very easy cleaning and maintenance.

Two different types of solder residue chambers are available:
metal and glass.

Tips are easily placed by thread.

Weight of DR desoldering iron 254 gr.
Supplied with tip C560-003.



Types of solder chambers

Glass

Metal



Vacuum connector



Desoldering DR-A

Desoldering tip

Desoldering body



Tools

AP-A Soldering wire feeding iron

The AP-A soldering wire feeding iron offers a 'third hand' by feeding soldering wire from diameters 0.8 to 1 mm. Specifically helpful for high-volume soldering jobs, and whenever an extra hand is needed.

The iron connects to JBC stations DI, DD, DM, AM and Single line AP.

Weight of AP-A solder feed iron 234 gr.
Supplied with cartridge C130-403.

Fume extractor

F1204 For AP-A solder feed iron



SN5450 Solder reels for AP-A

The soldering irons are fitted with lead free solder reel - 99% Sn / 0,3% Ag / 0,7% Cu - with 50g solder.





PREMIUM line Stations

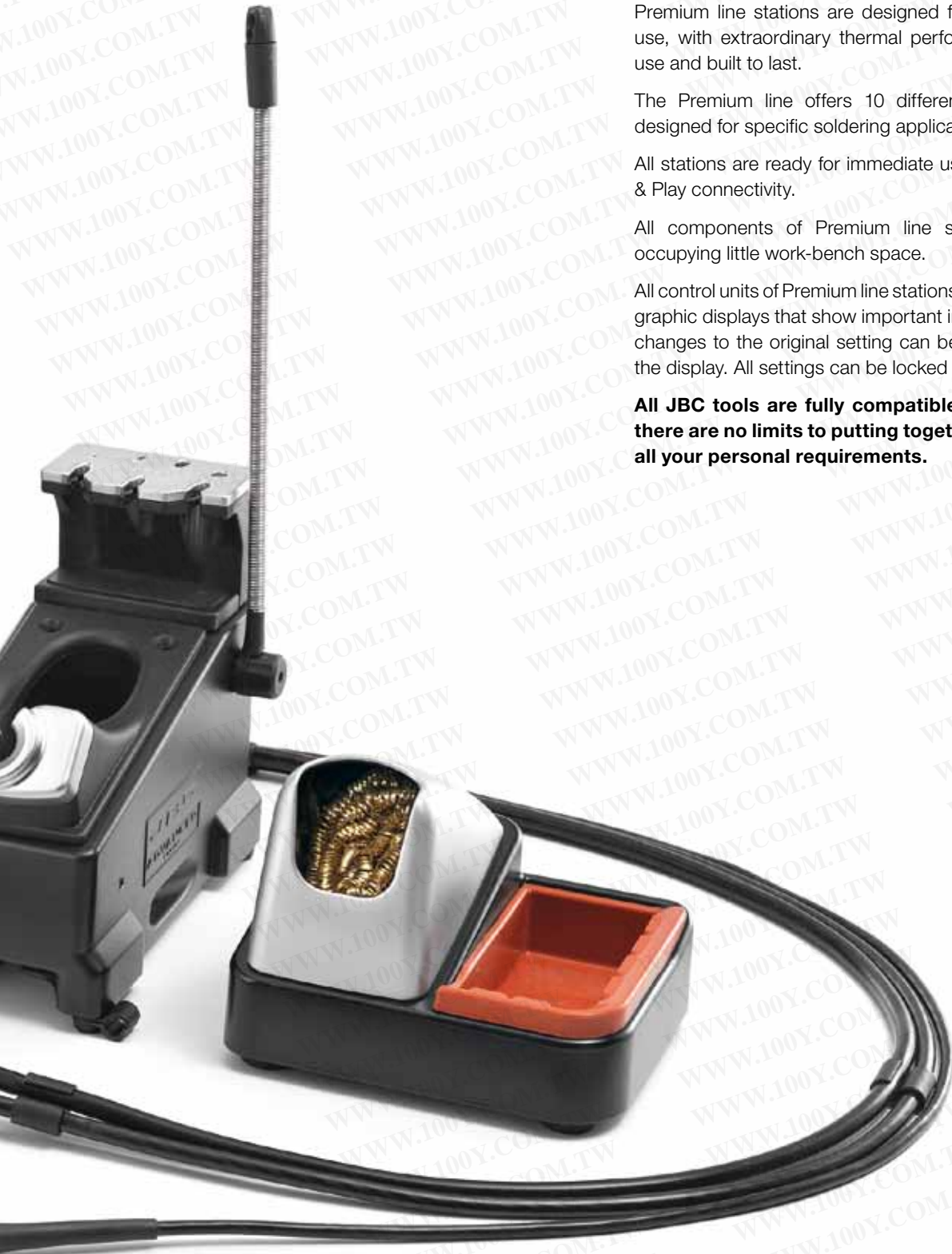

Premium line stations are designed for industrial and extensive use, with extraordinary thermal performance. They are easy to use and built to last.

The Premium line offers 10 different models, each of them designed for specific soldering applications.

All stations are ready for immediate use; all stations feature Plug & Play connectivity.

All components of Premium line stations are stackable for occupying little work-bench space.

All control units of Premium line stations feature large high-contrast graphic displays that show important information at a glance. Any changes to the original setting can be easily made via menu on the display. All settings can be locked by PIN.

All JBC tools are fully compatible to all control stations; there are no limits to putting together a station that covers all your personal requirements.

DDST Soldering & desoldering station

DIT and DIR Soldering stations

DIT-1B Soldering station 120V

For general electronic applications.

Included Control unit DI-1B
Stand AD-SB
Soldering iron T245-A
Cartridge C245-003

Basic specifications

Nominal power: 75 W
Total peak power: 140 W
Temperature selection: 300-450 °C
Weight: 2 kg

DIR-1B Soldering station 120 V

For high and medium precision solder-joints.

Included Control unit DI-1B
Soldering iron T210-A
Cartridge C210-001
Stand AD-SB
CL9885 Tip Cleaning Stand

DI-1B
Control unit for 1 tool

ADB
Stand

CL9885 Tip cleaning stand

T245
Handpiece

T210
Handpiece

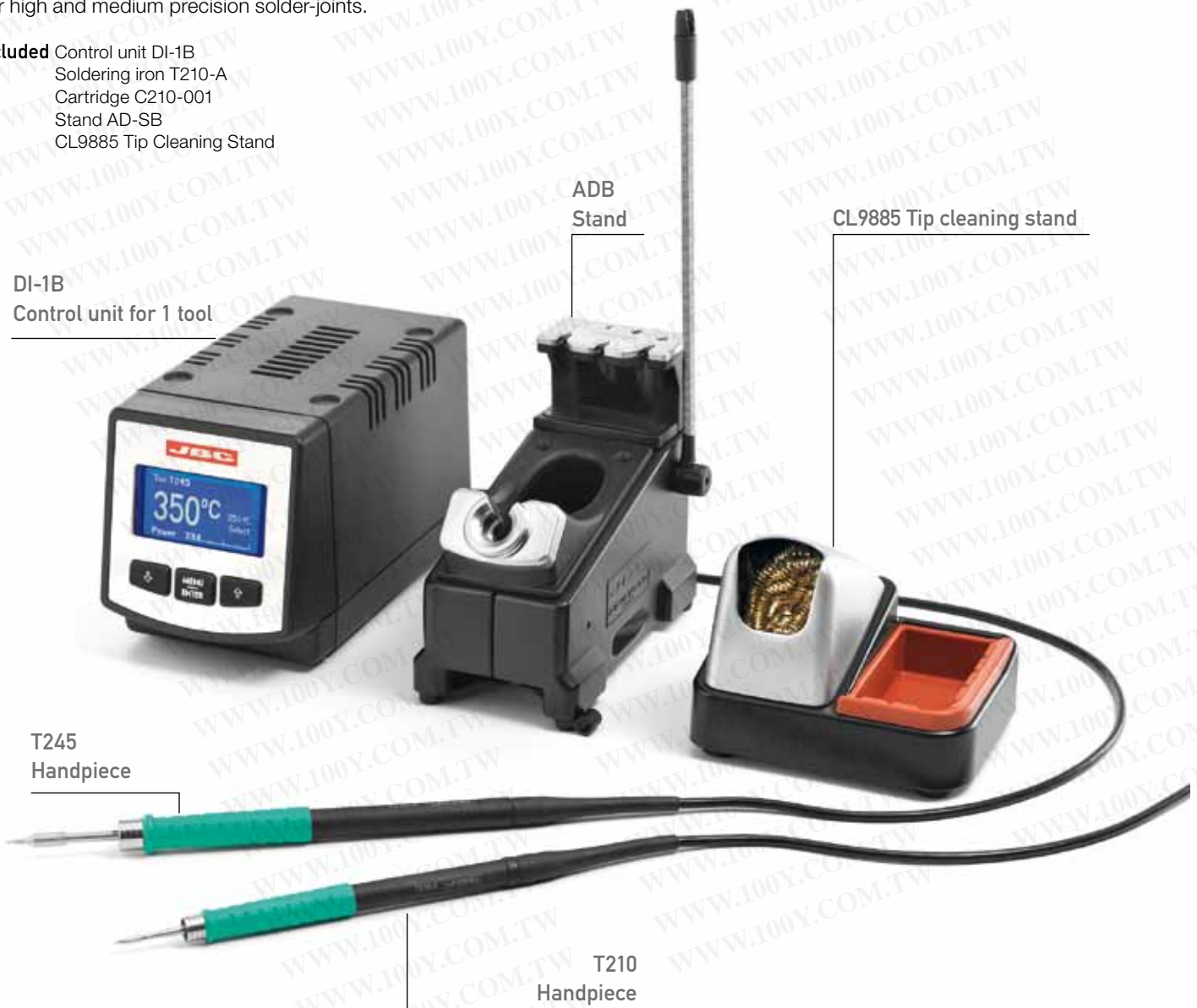

DIS, DIV and DSS Desoldering Station

DIS-1B and DIV-1B Desoldering station 120V

For desoldering insertion components and cleaning circuits with SMD components.

- Included**
- Control unit DI-1B
 - Desoldering iron with tip C560-003
 - Stand DR-SB
 - MS-A Suction module electric system
 - MV-A Suction module pneumatic system
 - CL9885 Tip Cleaning Stand
 - Accessories set

Basic specifications

- Nominal power: 75 W
- Total peak power: 140 W
- Temperature selection: 300-450 °C
- Weight: 2 kg

DSS-1B Micro desoldering station 120V

For desoldering small and medium-sized insertion components; high-precision station with small measurements.

- Included**
- Control unit DI-1B
 - Desoldering iron DS-A with tip C360-004
 - Stand DS-SB
 - MS-A Suction module electric system
 - CL9885 Tip Cleaning Stand
 - Accessories set



DIN Nitrogen soldering Station

DIN-1B Nitrogen soldering 120V

The DIN-1B Nitrogen soldering station combines 2 ways of transferring heat:

- By direct contact between the solder tip and the solder joint, just like a normal soldering iron
- By nitrogen which is heated when flowing through the soldering tip.

Included DI-1B control unit
MN-A Nitrogen flow regulator
Stand DN-SB
CL9885 Tip Cleaning Stand
Nitrogen handpiece T245-NA with C245-003

Basic specifications

Nominal power: 75 W
Peak power: 140 W
Temperature range: 90 - 450 °C
Weight: 1,2 kg

MN-A Nitrogen flow regulator

N₂ Flow regulation: 0,5 - 3,5 LPM at 5 Bar.
Max. Pressure: 6 Bar.

**An external nitrogen circuit is needed or the nitrogen generator from JBC GN-A*

GN-A Nitrogen module generator

Compressed air pressure: 4 to 6 Bar
Gas N₂ concentration: Up to 99,9 %
Concentrated N₂ gas flow: 1 to 2 NL/min.
Weight: 2 Kg.



MN-A
Nitrogen flow regulator

DI-1B
Control unit for 1 tool

DN-SB
Stand

CL9885 Tip cleaning stand

T245-NA
Nitrogen soldering iron

DDST and DDVT Rework station

The station DDST and DDVT offers a complete solution for fast and safe repair of insertion component circuits by suction of the solder. The station can also be used for cleaning pads in SMD circuits.

The station features all of JBC's technological advantages, like fast thermal recovery, sleep mode, small footprint, low weight, and easy handling of soldering and desoldering irons.

In addition to the standard functions soldering and desoldering, this station also offers connectivity of any JBC series tool to both modules (but only 1 desoldering iron).

MS-A electric suction module

MS-A pneumatic suction module

DD-1B
Control unit



DDST-1B and DDVT-1B Soldering & desoldering station 120V

Basic specifications

Nominal power: 2 x 75 W
 Peak power: 2 x 140W
 Sleep mode power: 2 x 10W
 Hibernation mode power: 2 x 4W
 Temperature selection between: 90-450° C
 Weight: 4,5 kg

Included Control unit DD-1B
 Handpiece T245-A
 Cartridge C245-003 and C245-006
 Desoldering DR-A
 Tip C560-003
 Stand AD-SB
 Stand DR-SB
 CL9885 Tip Cleaning Stand
 MS-A Suction module electric system
 MV-A Suction module pneumatic system
 Set of tools and accessories



DR
Desoldering

T245
Handpiece



DR-SB
Stand

AD-SB
Stand

CL9885 Tip cleaning stand

RMST Rework station

The AM rework station was designed for rework and repair of through-hole and SMT boards. The station's 4 modules offer the following rework/repair operations:

Desoldering of SMD components of any size by hot air. JBC's exclusive system of using jointly extractors/protectors and hot air, which offers safe, fast and clean desoldering, limits heat to the component to be desoldered, while it protects the rest of the circuit.

Desoldering SMT and through-hole components, and pad cleaning. For this operation this station features the desoldering iron DR-A and an integrated vacuum pump.

Pick & Place tip for placing components.

Soldering of any kind of components with the quick response and recovery features which are typical of all JBC stations.

The AM rework station features sleep and hibernation modes, as well as all other features of JBC stations.

This station can be easily controlled thanks to accurate information shown on a large-size display. For maximum user friendliness and adaptation to individual preferences, all functions can be saved and locked by PIN.

Modular extension of this station offers almost unlimited connectivity to the JBC tools range: soldering and desoldering irons, desoldering tweezers and soldering wire feeding irons.

MS-A electric suction module

DD-1B Control unit

JTE-1A Control unit

Características básicas

- Nominal power: 2 x 75 W
- Peak power: 2 x 140W
- Sleep mode power: 2 x 10W
- Hibernation mode power: 2 x 4W
- Air pump for hot-air with electronic control of temperature and air flow.
- Vacuum pump for holding ICs.
- Maximum Power: 1000 W.
- Temperature selection: °C or °F,
- Temperature room - 450° C and "cool"
- Air flow regulation: 6-45 l/min.
- The system is protected against antistatic discharge.
- Weight of complete system: 13 kg.



Heater

REPAIR PROCESS OF A CIRCUIT WITH SMD COMPONENTS



Desoldering IC component with hot air



Cleaning pads with desoldering iron



Placing component



Soldering from 2 opposite angles



Fluxing IC pads and leads



Soldering leads with special JBC series tips for soldering SMDs

DR-SB desoldering stand

AD-SB handpiece stand

RMST-1A Rework station 120V

Included

- Control unit DD-1B
- Control unit JTE-1A
- Handpiece T245-A
- Cartridge C245-003 and C245-006
- Desoldering DR-A
- Tip C560-004, C560-005 and C560-013
- Stand AD-SB
- Stand JT-SB
- Stand DR-SB
- CL9885 Tip Cleaning Stand
- MS-A Suction module electric system
- Heater 1000 W
- Extractor stand with 5 extractors, 5 protectors and two tripods.

CL9885 Tip cleaning stand

DR Desoldering Iron

T245 Handpieces

JT High power hot air station

The JT-1A station is a high power hot air station used for desoldering all types of SMDs.

Its powerful heater desolders even the biggest QFPs and PLCCs quickly and safely. Desoldering small and medium-sized BGAs is done in a very short time.

Digital readout of temperature and airflow offers maximum accuracy and control.

JBC's exclusive system uses jointly extractors/protectors and hot air for fast desoldering and protecting the surrounding components by concentrating heat on the component to be desoldered.

As an example, desoldering an integrated, medium-sized QFP can be finished in approximately 20 seconds.

JT-1A High power hot air station 120V

Basic Specifications

Air pump for hot-air with electronic control of temperature and air flow.

Vacuum pump for holding ICs.

Maximum Power: 1000 W.

Temperature selection: °C or °F,

Temperature room - 450° C and "cool"

Air flow regulation: 6-45 l/min.

The system is protected against antistatic discharge.

Weight of complete system: 8,7 kg.

Included Control unit JTE-1A
Heater 1000 W
Extractor stand with 5 extractors, 5 protectors and two tripods.
Heater stand and set of accessories.



Desoldering a QFP with the system JT or TE

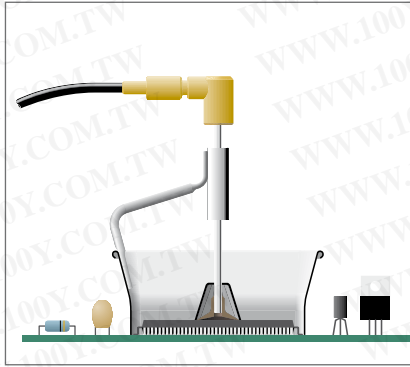

1. Place the extractor.

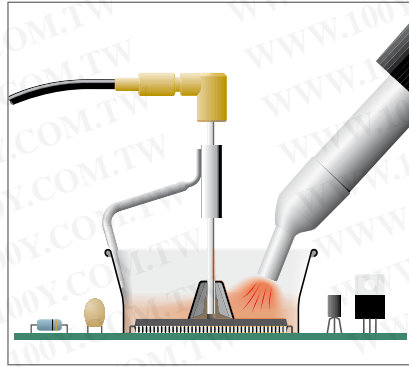

2. Heat until is undone soldering joint.

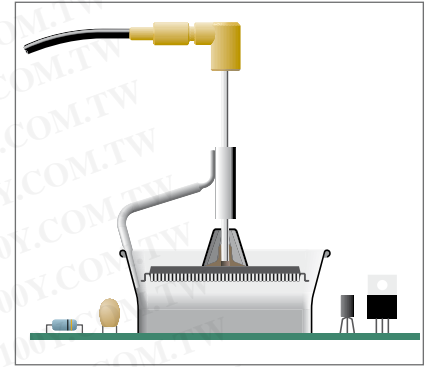

3. Desoldered IC is removed automatically.

20 seconds to desolder a medium QFP.

PROTECTORS



¹Supplied with the station JT-1A
²Supplied with the station TE-1A
 A and B are inner workable areas.

Ref.	Amm	Bmm
P3353	4,3	3
P3786	5,2	5,2
P3352	5,2	7,5
P3355	5,2	9,5
P3356	6,2	4,2
P3785	7,2	7,2
P3784	8,2	8,2
P4035	9	13
P4040	9,5	19
P4080	9,5	21
^{1-2 32} P2220	10	10
P4045	10,5	21
P4090	11	16
^{1-2 24} P2235	12	17
P1249	12	23

^{1-2 44} P4000	12,5	12,5
P1593	13	31,5
P3354	13,2	13,2
P4025	13,5	21,5
^{1-2 48} P2230	15	15
^{1-2 60} P4010	17	17
P4005	18	29
P4030	18,5	18,5
P1068	18,5	24
P2685	28,5	28,5
P4085	31,5	31,5
P2672	33	46
P4002	50	50
P3357	52,5	14

EXTRACTORS



Ref.	Amm	Bmm
E2052	20	20
E2064	20	26
^{1-2 80} E2184	24	24
^{1 68} E2068	27	27
^{1-2 52} E4020	28,5	28,5
^{1-2 64} E4015	31,5	31,5
^{1 84} E2084	33	33
100 E2100	38	38
124 E2124	45	45

TRIPODS



Ref.	øCmm
¹⁻² T2050	39
T2250	85



E2190
Manual extractor

TE Hot air station

The TE-1A is a precision hot air station ideal for soldering and desoldering small and medium-sized SMD components.

With the TE-1A hot air station it takes approximately 30 seconds to desolder medium-sized components, fast enough to prevent the substrate and the component from being exposed to harmful temperatures. In combination with JBC's unique system of extractors, the TE-1A hot air station is the safest hot air desoldering system available in the market.

TE-1A Precision hot air station 120V

Basic specifications

Autonomous hot air station, digital, thermo regulated with air flow control.

Power maximum out: 300 W.

Temperature selection: °C or °F, Room - 450 °C and cool

Variable air flow settings between 4 and 11 l/min.

Weight of complete system 6,7 Kg.

Included Control unit JTE-1A
Heater 300 W.
Heater stand JT-SA
Accessories.
Extractor stand with 2 tripods,
3 extractors and 5 protectors.



HD Heavy duty station

The HD-1B heavy duty station is the ideal solution for high thermal demand and prolonged heavy duty soldering applications.

This station was specifically designed for extensive soldering of multi-layered circuits and parts which require high temperatures.

The temperature of the tip is controlled by a sensor integrated in the heater, which permits quick temperature recovery.

The HD heavy duty station offers high reliability for extensive applications as for example the production of solar panels.

The HD heavy duty station features sleep and hibernation modes, as well as all other features of JBC stations.

The T245-A handpiece can be connected to the station using the C470 cartridge range.

HD-1B Heavy duty 120V

Basic specifications

Nominal Power: 145 W.
Total peak power: 270 W.
Sleep mode: 20 W
Hibernation mode: 9 W
Temperature Range: 90 - 500° C.
Weight: 4,5Kg.

Included Control unit HD-1B
Stand HD-SB
CL9885 Tip Cleaning Stand
Handpiece T245-TA

HD-1B
Control unit

HD-SB stand

CL9885 Tip cleaning stand

T245-TA
Handpiece

AL Automatic Solder feed station

The AL automatic solder feed station is the ideal solution for extensive soldering application, and any soldering application that requires one or two free hands.

This station automates the soldering process by feeding soldering wire, using all advantages of JBC soldering stations.

With the AL-1A automatic solder feed station it is possible to:

- Select length and speed of wire feeding
- Select work cycle: continuous or step-by-step
- Capture and control of work hours and solder cycles

AL-1A
Control unit

AL-1A Solder feed station 120V

Basic specifications

Nominal power: 75 W.
 Peak power: 140 W
 Sleep mode: 10 W
 Hibernation mode: 4 W
 Temperature regulation: 90 - 450 °C.
 Uses soldering wire diameters 0.5 to 1.5 mm, with appropriate wire guide accessories
 Capacity of solder reels up to 2 Kg.
 Weight: 3,2 kg.

Included Control unit AL-1A
 Complete handle AL-A
 Cartridge C250403
 Stand AL-SB
 CL9885 Tip Cleaning Stand
 Tubes set and guides, for: wires
 ø 0,9 - 1 mm: 0002401

AL 2500 station accessories

Tubes set and guides for:

wires ø 0,4 - 0,5 mm P/N.: 0002399
 wires ø 0,6 - 0,8 mm P/N.: 0002402
 wires ø 0,9 - 1,0 mm P/N.: 0002401
 wires ø 1,0 - 1,5 mm P/N.: 0002843

Pedal set with cable and connector

Ref.: 0964551

Fume extractor accessory AL-A

Ref.: 0004468

Arm for soldering iron AL

Ref.: AL-1A



AL-A

BE-SA Solder reel stand

The ideal accessory for easy soldering wire supply.

Specifications

Can be used vertically and horizontally.
For reels in standard DIN sizes.
Capacity: reels of 1 kg and 2,5 Kg maximum.



AL-SB stand

AL-SA stand

AL-IA Hands-free soldering arm for soldering iron AL

Indispensable for using the AL system while having both hands free. For this purpose it is also necessary to use the pedal set Ref. 0964551



NAST Nano station

The Nano station is a complete station designed for micro soldering and desoldering of small-size components like chips 0201, 0402 etc.

Tools for this station; Nano soldering iron NT205-A and nano tweezers NP105-A are the lightest, tiniest and ergonomic of the market, which allows you to work at highest precision.

The control unit is fully compatible with either tweezers or irons.

NAST-1A Station 120V

Basic specifications

Nominal Power 15W
 Peak power 30W
 Temperature regulation: 90-450° C
 Weight: 2,6 kg

Included Control unit NA-1A
 Nano soldering iron NT205-A
 Nano tweezers NP105-A
 Cartridge set x 2 (10 pcs)

Set: C105-101
 C105-103
 C105-105
 C105-108
 C105-111

NP 105-A Nano tweezers



C105 Cartridges for iron NA

E 1:1

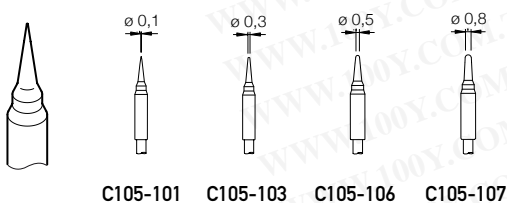

C105-101 C105-103 C105-106 C105-107

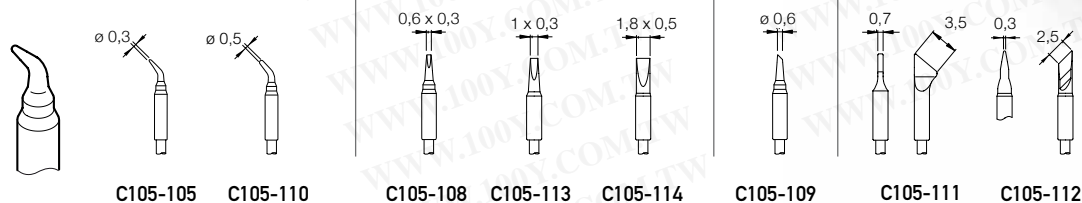

C105-105 C105-110 C105-108 C105-113 C105-114 C105-109 C105-111 C105-112



NT 205-A
Nano soldering iron

A1205 Extension cord

Cartridges

E 1:1

C105 Cartridges for iron NA

Galvanic treatment tips offers outstanding thermal performance and long duration.

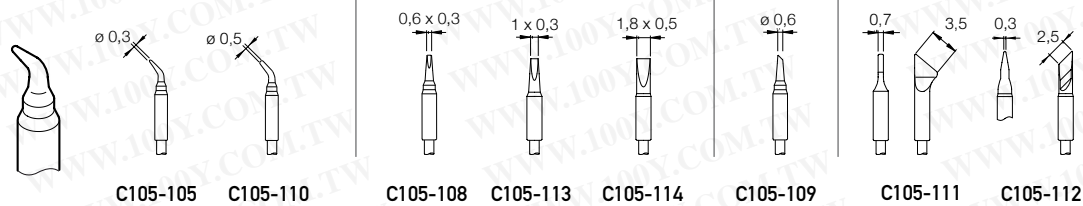
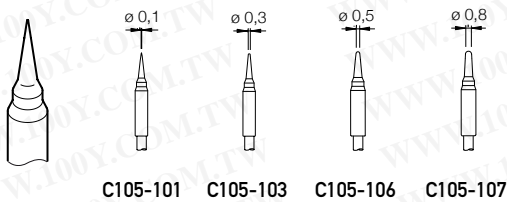

Cartridges

E 1:1

C120 Cartridges for microtweezers PA handpiece

Galvanic treatment tips offers outstanding thermal performance and long duration.



CHIPS COMPONENTS

C120-002

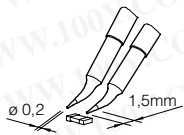

C120-902

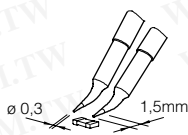

C120-006

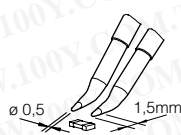

C120-004

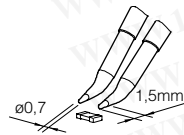

DUAL IN LINE

C120-001

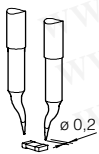

C120-003

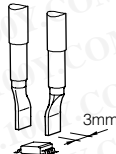

C120-005

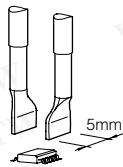

C120-007



C120-008

C120-009

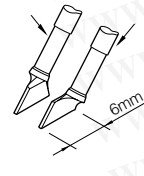

C120-010

Cartridges

E 1:1

C130 Cartridges for solder feed AP iron

Galvanic treatment tips offers outstanding thermal performance and long duration.

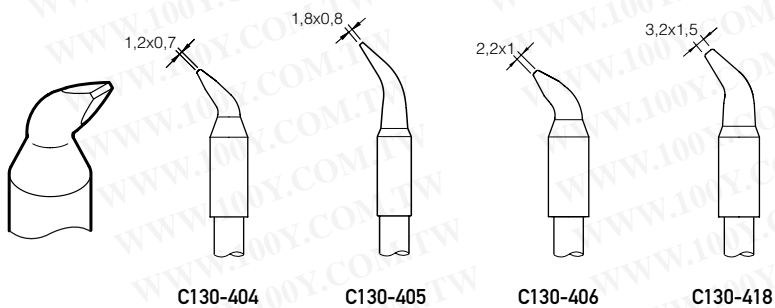
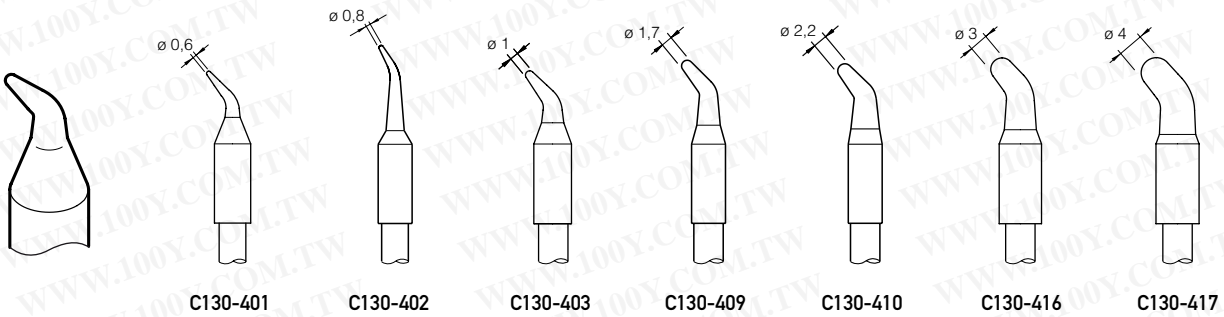

Cartridges

E 1:1

C210 Cartridges for T210 handpiece

Galvanic treatment tips offers outstanding thermal performance and long duration.

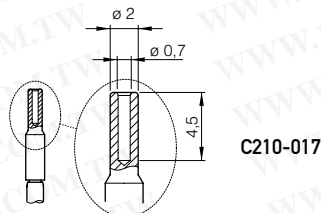
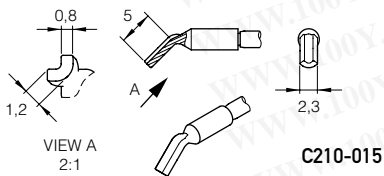
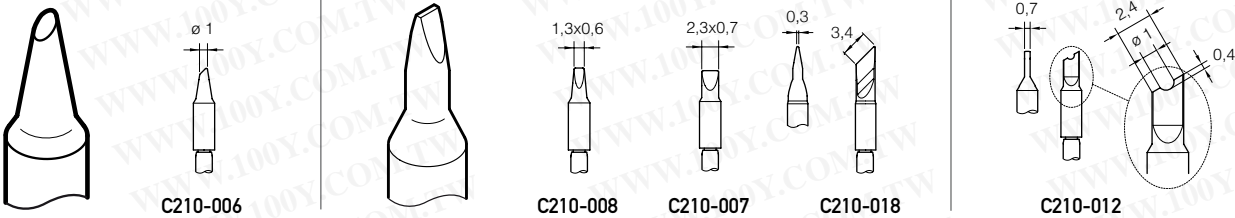
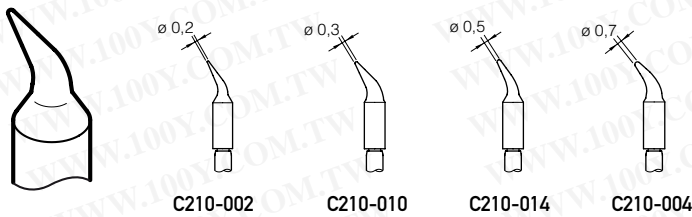
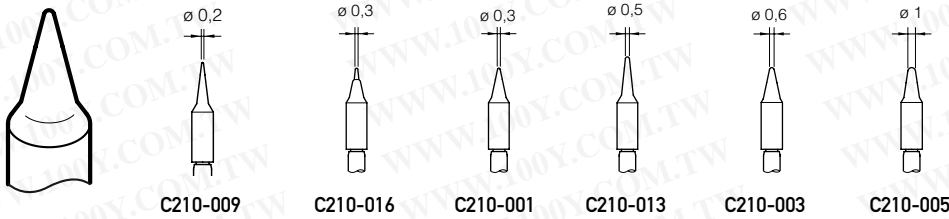

Cartridges

E 1:1

C245 Cartridges for T245 handpiece

Galvanic treatment tips offers outstanding thermal performance and long duration.

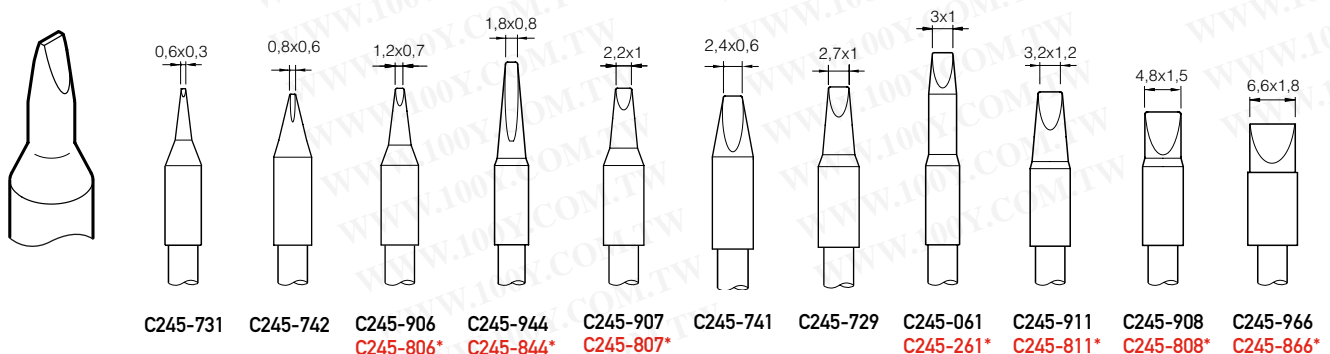
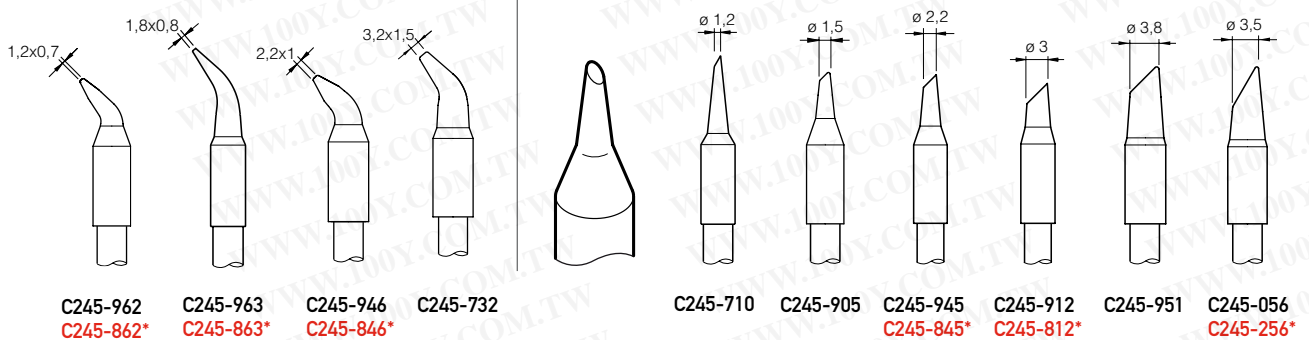
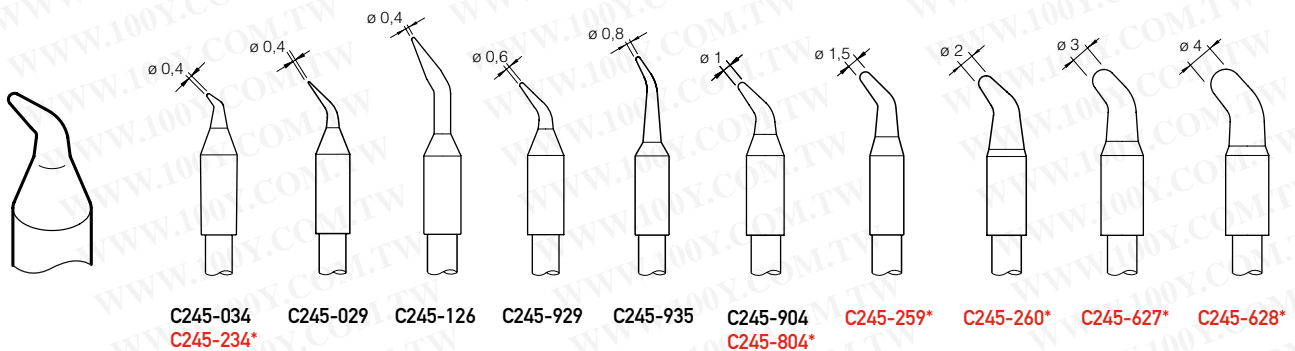
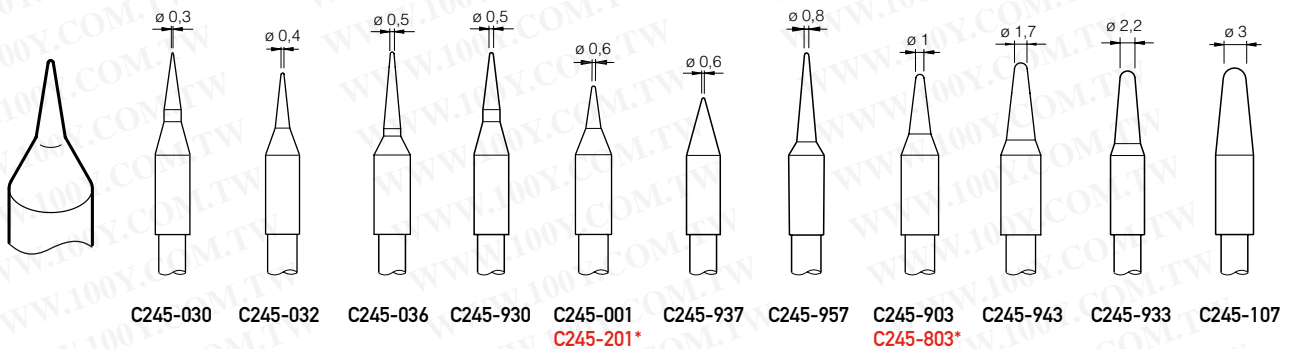

*These cartridges are 20mm longer than normal cartridges for easy access to applications difficult to reach.

Cartridges

E 1:1

MINI SPOON



C245-067

CHIP COMPONENTS



- C245-019 A=4,5
- C245-018 A=3,4
- C245-017 A=2,2
- C245-016 A=1,9

QFP Y PLCC

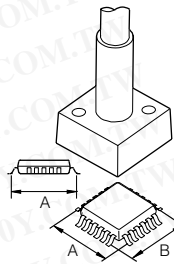

- C245-227* A=17,5 B=17,5
- C245-315* A=15 B=15,0
- C245-228* A=12,4 B=15,0
- C245-224* A=12,0 B=12,0
- C245-223* A=8,5 B=8,5

CARTRIDGES TO SOLDER SMT IC

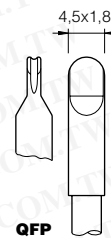

QFP

C245-009

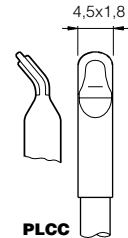

PLCC

C245-010

FOR PLCC SOCKETS

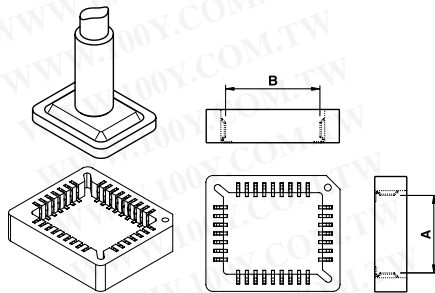

C245-248*
N. of contact positions= 32
A=11,9 B=14,5

C245-247*
N. of contact positions= 44
A=17,0 B=17,0

MINI SPOON



- C245-938 ØA=3,8
- C245-931 ØA=2,7
- C245-965 ØA=1,9

BLADE TYPE

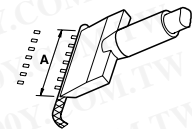

- C245-949 A=32
- C245-913 A=21
- C245-914 A=10

BEVEL EDGE TIPS

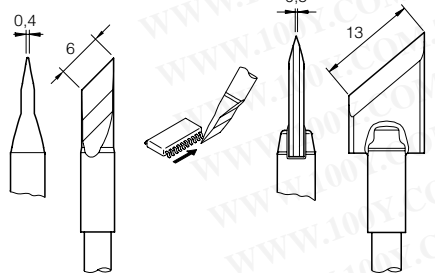

C245-939

C245-955

DUAL IN LINE

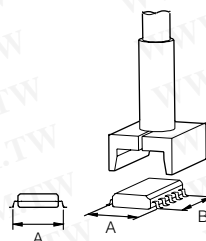

- C245-226* A=15,2 B=29,0
- C245-215* A=9,6 B=18,0
- C245-304* A=9,6 B=15,0
- C245-305* A=9,6 B=12,0
- C245-306* A=9,6 B=10,0
- C245-222* A=7,1 B=13,0
- C245-303* A=6,5 B=6,0
- C245-221* A=5,4 B=10,0
- C245-250* A=5,4 B=8,0
- C245-220* A=5,4 B=6,0

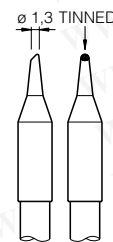

C245-064

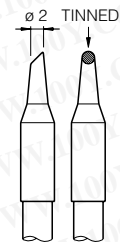

C245-102

*These cartridges are 20mm longer than normal cartridges for easy access to applications difficult to reach.

Cartridges

E 1:1

C245 Cartridges for T245 handpiece

CARTRIDGES WITH CHROME FINISH, DESIGNED FOR USE PLASTIC RIVETS:

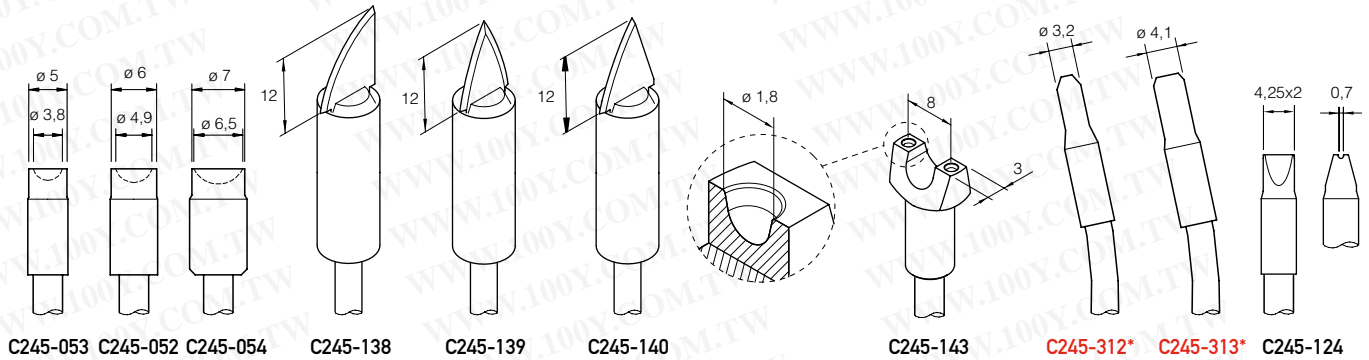

CARTRIDGES WITH BIG CONTACT SURFACE TO SOLDER WIDE AREA:

CARTRIDGES SPECIAL PRODUCED FOR FAST SOLDERING ON MALE CONTACTS:

TEFLON COATED TIP

SPECIAL CARTRIDGE FOR THROUGH HOLE SOLDERING:

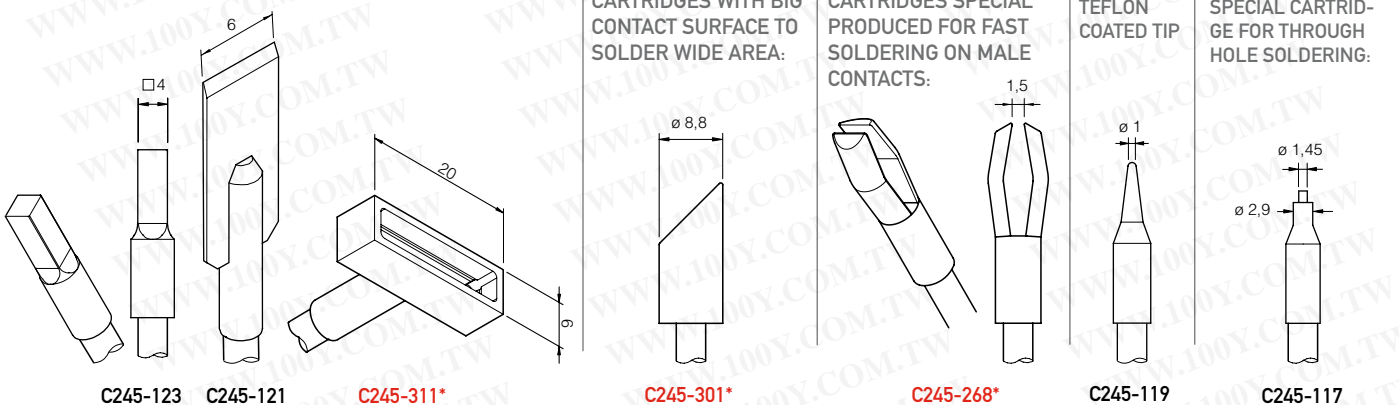

EXTRA IRON COATED TIP, SPECIAL FOR ROBOTS:

CHISEL TIP (similar to the 245-908 but longer and more conical):

CUTTER (Not tinned):

REWORK BLADE:

CABLE SOLDERING

TIP WITH AN EXTRA TINNED SURFACE:

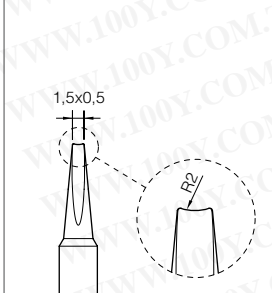

TO SOLDER INSIDE A CONNECTOR

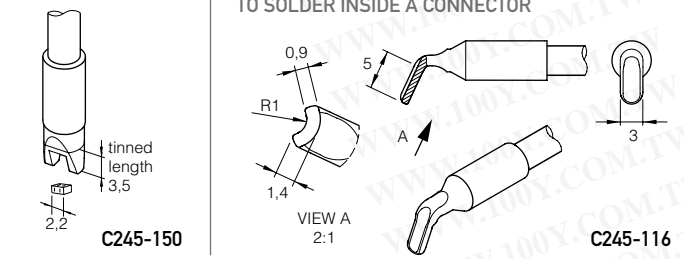

*These cartridges are 20mm longer than normal cartridges for easy access to applications difficult to reach.

Cartridges

E 1:1

C250 Cartridges tip for AL iron

Galvanic treatment tips offers outstanding thermal performance and long duration.

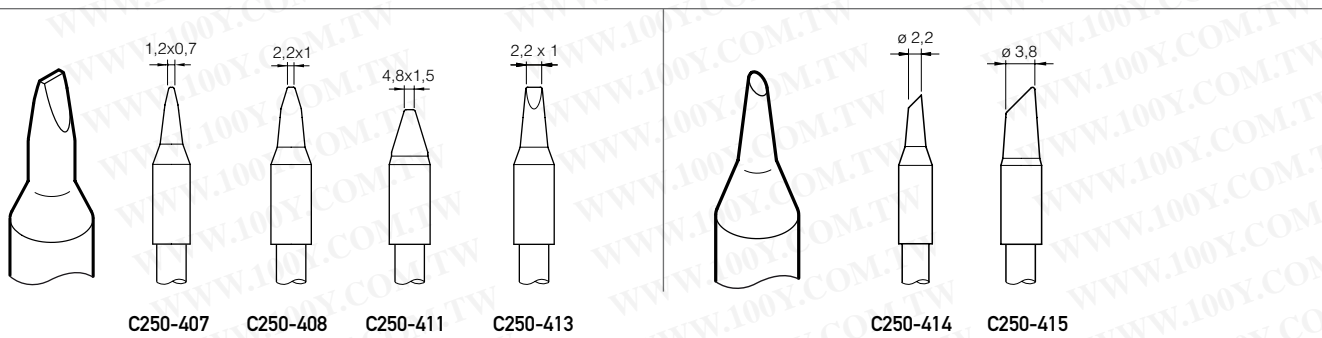
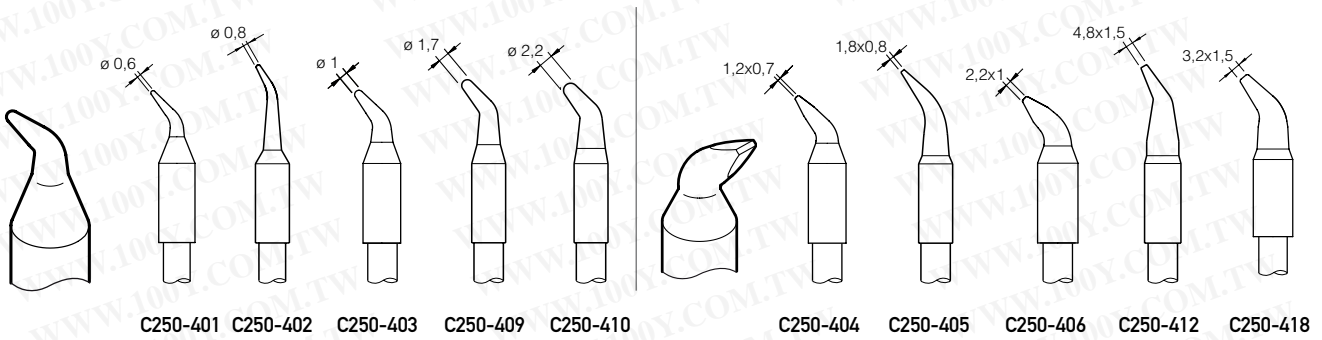

Desoldering tips

E 1:1

C360 Tips for Microdesoldering DS iron

Galvanic treatment tips offers outstanding thermal performance and long duration.

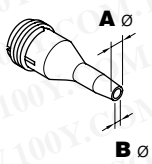

C360-001



ØA=1
ØB=0,6
Ømax. pin=0,4

C360-002



ØA=1,2
ØB=0,8
Ømax. pin=0,6

C360-003



ØA=1,4
ØB=1
Ømax. pin=0,8

C360-004



ØA=1,6
ØB=1,2
Ømax. pin=1

C360-006

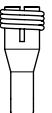

ØA=3
ØB=1,5
Ømax. pin=1,3

PAD CLEANING tip for DR iron

The pad cleaning tips feature a distinctive contact surface slit which offers circulation of suction air for easy pad cleaning.

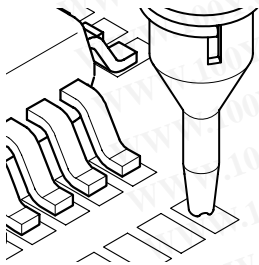

STANDARD PAD CLEANING TIP FOR DR

C360-011



ØA=1
ØB=0,6

C360-012



ØA=1,2
ØB=0,8

C360-013



ØA=1,4
ØB=1

C360-014



ØA=1,6
ØB=1,2

E 1:1

Cartridges

E 1:1

C420 Cartridges for HT tweezers

Galvanic treatment tips offers outstanding thermal performance and long duration.



CHIPS COMPONENTS

C420-271 Amm=1,5

C420-272 Amm=2,6

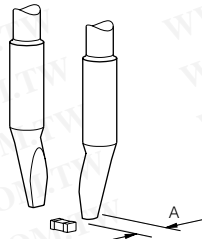

BLADE TYPE

C420-283 Amm=50

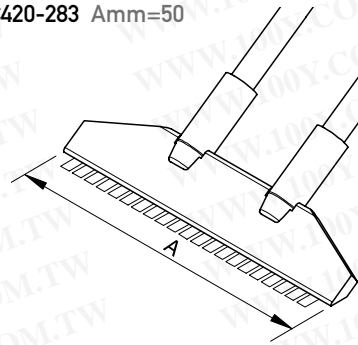

QFP Y PLCC

C420-279 Amm=8,0

C420-280 Amm=11,0

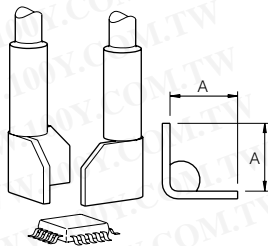

CABLE STRIPPER

C420-281 Amm=3,5 max.

C420-282 Amm=3,5 max.

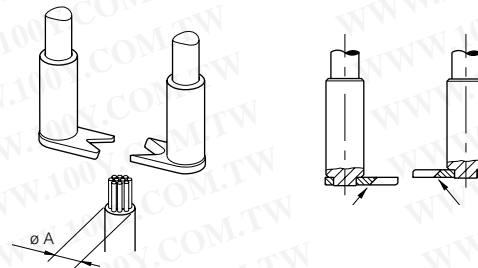

DUAL IN LINE

C420-273 Amm=4,0

C420-274 Amm=6,0

C420-275 Amm=8,0

C420-276 Amm=10,0

C420-277 Amm=15,0

C420-278 Amm=20,0

C420-285 Amm=22,0

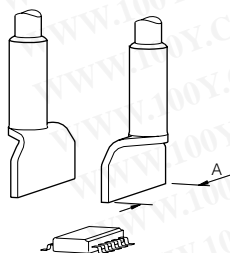

C420 Special Cartridges for HT tweezers

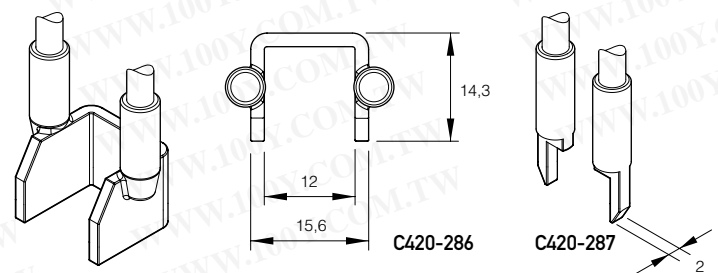

Supplied individually

Cartridges

E 1:1

C470 Cartridges for iron T245 with HD station

Galvanic treatment tips offers outstanding thermal performance and long duration.

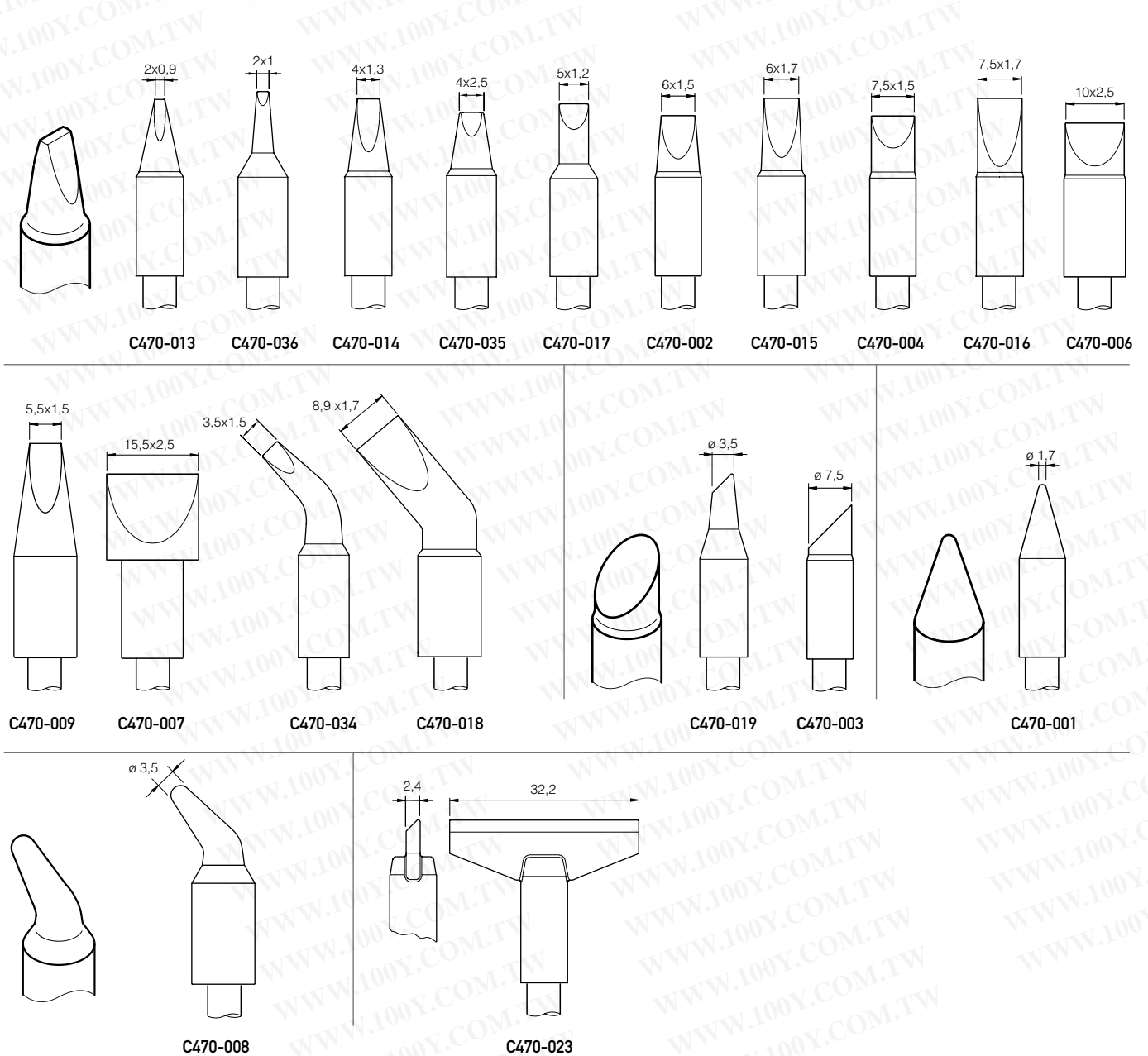

E 1:1

Cartridges

E 1:1

C470 Special cartridges for iron T245 with HD station

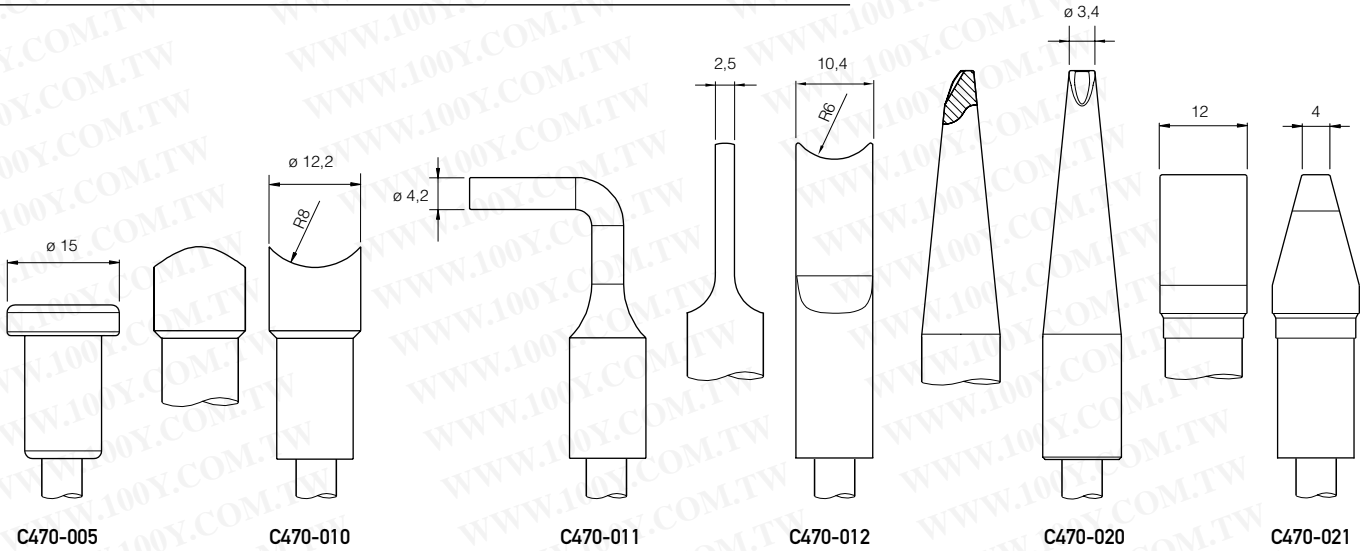

CARTRIDGES WITH CHROME FINISH, DESIGNED FOR USE PLASTIC RIVETS:

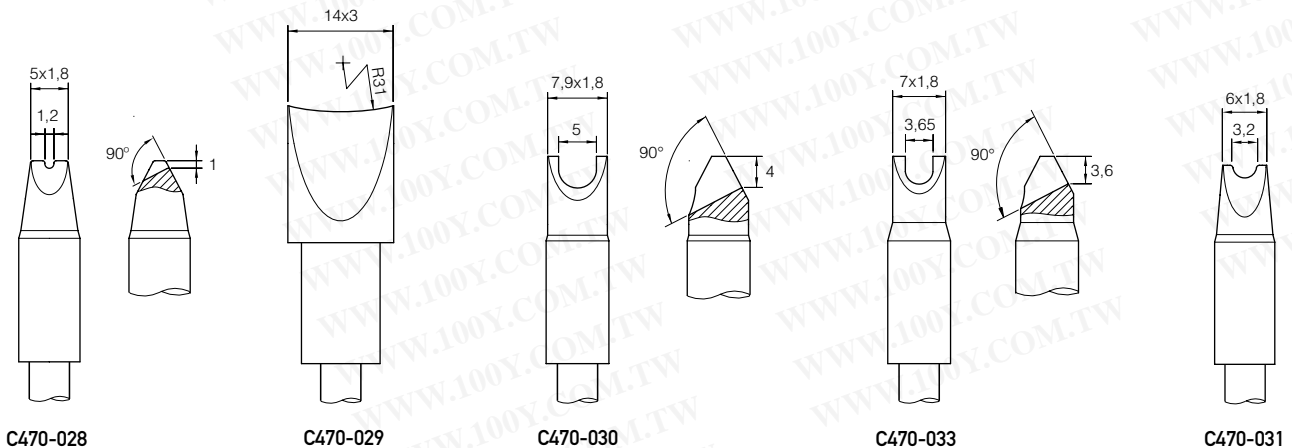
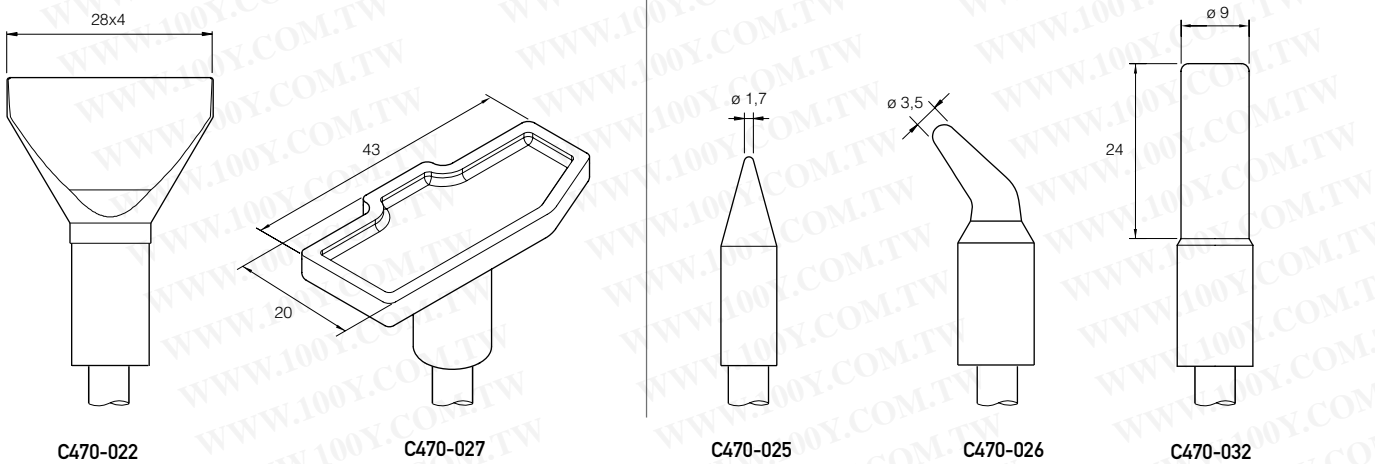

Desoldering tips

E 1:1

C560 Tips for Desoldering iron DR

Galvanic treatment tips offers outstanding thermal performance and long duration.

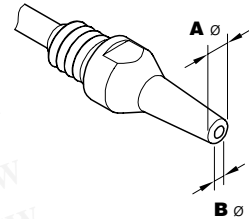

C560-001HT

$\varnothing A=1,4$ $\varnothing B=0,6$
 $\varnothing_{max. pin}=0,4$

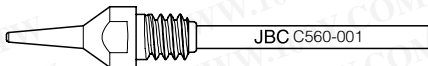

C560-002HT

$\varnothing A=1,8$ $\varnothing B=0,8$
 $\varnothing_{max. pin}=0,6$

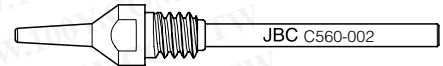

C560-014

$\varnothing A=2,5$ $\varnothing B=0,8$
 $\varnothing_{max. pin}=0,6$

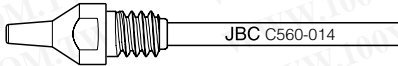

C560-003

$\varnothing A=2,7$ $\varnothing B=1$
 $\varnothing_{max. pin}=0,8$

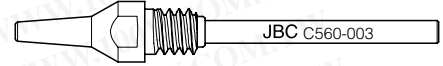

C560-004

$\varnothing A=3,2$ $\varnothing B=1,3$
 $\varnothing_{max. pin}=1,1$

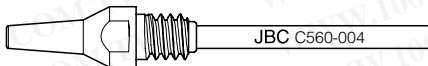

C560-009

$\varnothing A=5$ $\varnothing B=1,3$
 $\varnothing_{max. pin}=1,1$

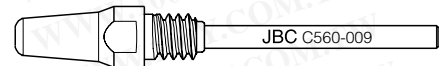

C560-005

$\varnothing A=3,4$ $\varnothing B=1,5$
 $\varnothing_{max. pin}=1,3$

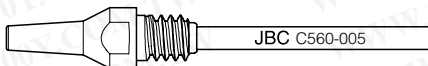

C560-006

$\varnothing A=4,2$ $\varnothing B=1,9$
 $\varnothing_{max. pin}=1,7$

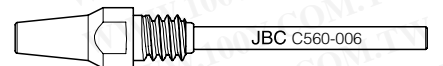

C560-007

$\varnothing A=4,8$ $\varnothing B=2,4$
 $\varnothing_{max. pin}=2,2$

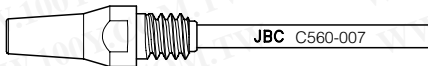

C560-015

$\varnothing A=5,2$ $\varnothing B=3$
 $\varnothing_{max. pin}=2,8$



PAD CLEANING Standard pad cleaning tip for DR iron

The pad cleaning tips feature a distinctive contact surface slit which offers circulation of suction air for easy pad cleaning.

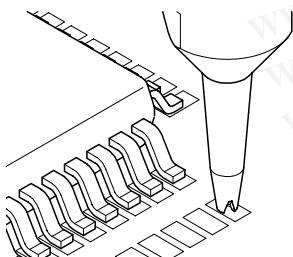

STANDARD PAD CLEANING TIP FOR DR

C560-011HT

$\varnothing A=1,4$ $\varnothing B=0,6$

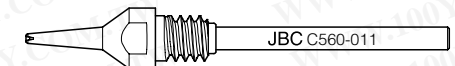

C560-012HT

$\varnothing A=1,8$ $\varnothing B=0,8$

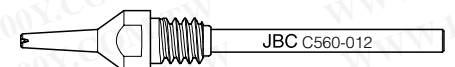

C560-013

$\varnothing A=2,7$ $\varnothing B=1$

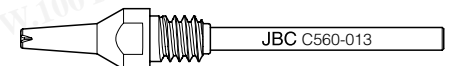

Accessories

勝特力材料 886-3-5753170
勝特力电子(上海) 86-21-34970699
勝特力电子(深圳) 86-755-83298787
[Http://www.100y.com.tw](http://www.100y.com.tw)

TI-A Thermometer

Accessory for measuring tip temperature.

Soldering right on the temperature measuring point offers accurate measuring of the real temperature of the solder joint.

For measuring the temperature in sleep mode a connection cable is included. P/N.: 0780476.

Specifications

Temperature range from 21 to 500 °C.

Replaceable sensor.

Resolution 10 °C.

Weight 0,7 Kg.

Size: width 165 mm,
height 75 mm,
depth 105 mm.



FL Flux

Flux specifically developed for resoldering of components in repaired circuits.

FL-15 Little bottle 15ml with applicator brush.

FL-50 Bottle 500 ml equipped with decanting tube.



FS500 Fume extractor switch

This accessory performs as a switch fumes suction system. The feed of a fume suction system is connected to the FS500 and this to the network acting as a switch. When the soldering iron is in the stand the fume suction system stops, returning to work by lifting the iron to use.

This accessory can be connected to the control units, DI, DD and DM.

