

REPLACEMENT PARTS/OPTION

Item No.	Part No.	Part Name	Specifications
①	A1236	Heating element	230V/50W *
②	A1002	Nozzle S	ø0.8 mm (0.03 in.)
	A1003	Nozzle S	ø1.0 mm (0.04 in.)
	A1004	Nozzle	ø0.8 mm (0.03 in.)
	A1005	Nozzle	ø1.0 mm (0.04 in.)
	A1006	Nozzle	ø1.3 mm (0.05 in.)
	A1007	Nozzle	ø1.6 mm (0.06 in.)
③	B1723	Element cover	
④	B1724	Nut	

*Power consumption of heating elements is 75W for Europe (CE) because of measuring point difference.

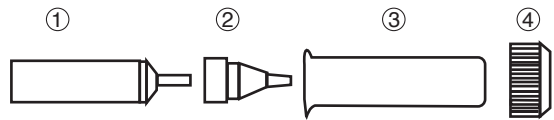

Item No.	Part No.	Part Name	Specifications
①	A1033	Ceramic paper filter (L)	10pcs.
②	B1747	Filter holder	
③	A1267	Pre-filter (ALUM)	5pcs.
④	B1725	Filter pipe	
⑤	A1217	Front holder	

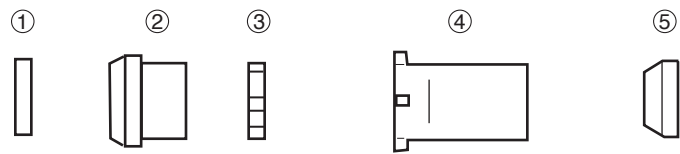

Item No.	Part No.	Part Name/Specifications
①	B1739	Pump cover
②	B1728	Inner hose (2 pcs.)
③	B1727	Back holder spring
④	B1726	Back holder
⑤	B1836	Pump assembly(230V / 50Hz)
⑥	B1743	Housing
⑦	B1341	Cord bushing
⑧	B3090	P.W.B. / Temp.Control (CE)
⑨	B3091	Micro switch
⑩	B1742	Trigger
⑪	B1811	P.W.B. / Motor(230V)
⑫	B1879	Rubber cap for CAL
⑬	B3093	CAP for CAL potentiometer
⑭	B3094	CAP for Temp. Control potentiometer
⑮	B3092	Power Cord , 3 wired cord & European plug
	B3096	Power Cord , 3 wired cord & BS plug

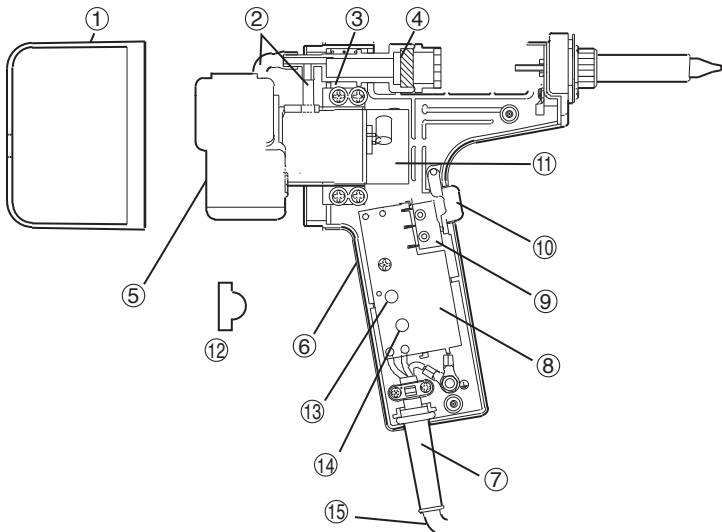

Part No.	Part Name	Specifications
B1215	Cleaning pin	For heating element
B1086	Cleaning pin	For ø0.8 mm (0.03 in.) nozzle
B1087	Cleaning pin	For ø1.0 mm (0.04 in.) nozzle
B1088	Cleaning pin	For ø1.3 mm (0.05 in.) nozzle
B1089	Cleaning pin	For ø1.6 mm (0.06 in.) nozzle
B1302	Cleaning drill	For ø0.8 mm (0.03 in.) nozzle
B1303	Cleaning drill	For ø1.0 mm (0.04 in.) nozzle
B1304	Cleaning drill	For ø1.3 mm (0.05 in.) nozzle
B1305	Cleaning drill	For ø1.6 mm (0.06 in.) nozzle
B1306	Drill holder	For ø0.8 mm (0.03 in.)/1.0 mm (0.04 in.) nozzle
B1307	Drill holder	For ø1.3 mm (0.05 in.)/1.6 mm (0.06 in.) nozzle
B1308	Drill bit	For ø0.8 mm (0.03 in.) nozzle (set of 10)
B1309	Drill bit	For ø1.0 mm (0.04 in.) nozzle (set of 10)
B1310	Drill bit	For ø1.3 mm (0.05 in.) nozzle (set of 10)
B1311	Drill bit	For ø1.6 mm (0.06 in.) nozzle (set of 10)
B1356	Adapter	
B3048	Wrench	
C1099	Carrying case	
C1100	Iron holder	
A1042	Cleaning sponge	

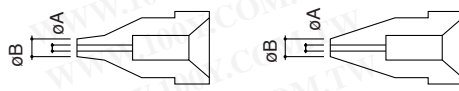

Part No.	øA	øB
A1002	0.8 mm (0.03 in.)	1.8 mm (0.07 in.)
A1003	1.0 mm (0.04 in.)	2.0 mm (0.08 in.)
A1004	0.8 mm (0.03 in.)	2.3 mm (0.09 in.)
A1005	1.0 mm (0.04 in.)	2.5 mm (0.1 in.)
A1006	1.3 mm (0.05 in.)	3.0 mm (0.12 in.)
A1007	1.6 mm (0.06 in.)	3.0 mm (0.12 in.)

Item No.	Part No.	Part Name/Specifications
①	B1732	Fixing plate
②	A1231	Valve plate (2 pcs.)
③	B1731	Pump head
④	B1832	Motor (230V / 50Hz)
⑤	B1736	Motor fixing support
⑥	B1734	Frame
⑦	B1735	Crank shaft
⑧	B1746	Ring for bearing
⑨	B1913	Crank
⑩	B1745	Spacer/4 × 4
⑪	A1230	Diaphragm (2 pcs.)
⑫	B1730	Diaphragm setting plate

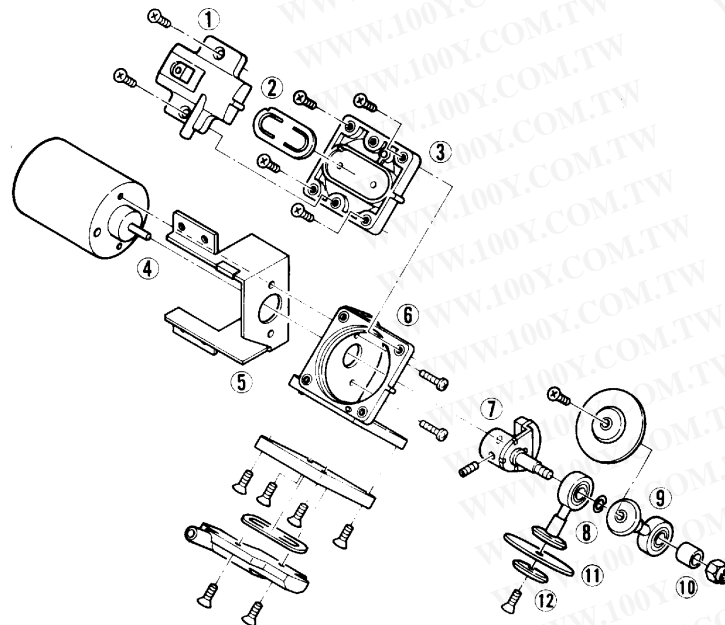

勝特力材料 886-3-5753170
 勝特力电子(上海) 86-21-54151736
 勝特力电子(深圳) 86-755-83298787
[Http://www.100y.com.tw](http://www.100y.com.tw)

HAKKO 808

DESOLDERING TOOL

Desoldering tool

Instruction Manual

Thank you for purchasing the HAKKO 808 desoldering tool.
 Please read this manual before operating the HAKKO 808.
 Keep this manual readily accessible for reference.

PACKING LIST

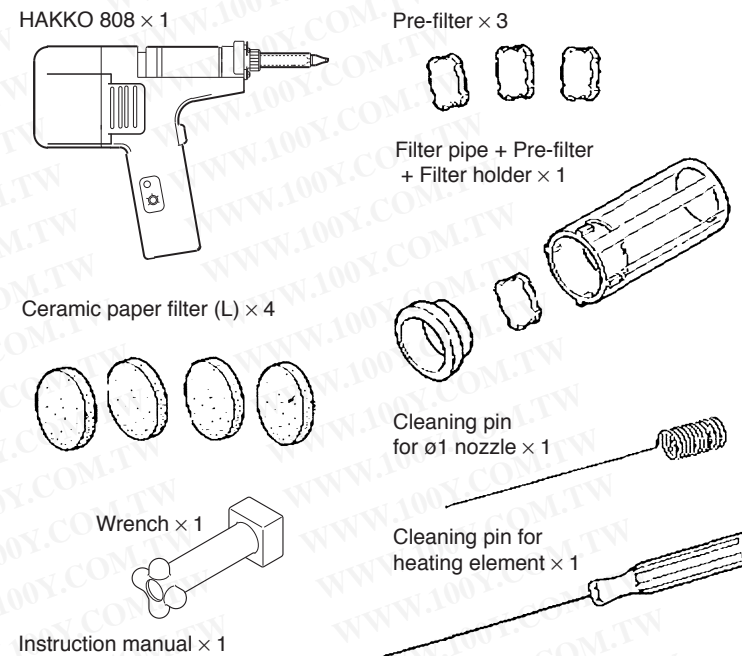

PART NAMES

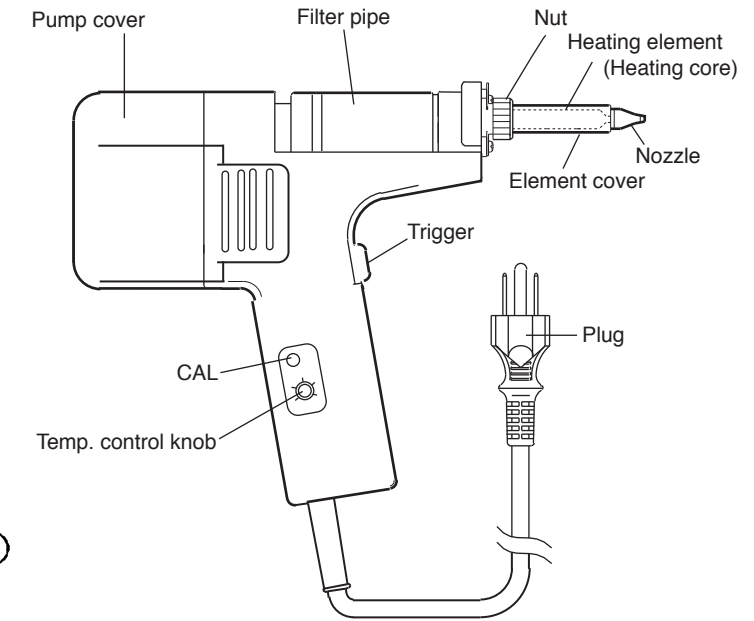

WARNINGS AND CAUTIONS

- The HAKKO 808 is an electrical tool used to melt and absorb solder in order to free components from the printed circuit boards, etc. The desoldering tool should not be used for any other purpose as this may damage the product or cause an accident or injury.
- Be careful when handling the desoldering tool. Do not drop it or otherwise subject it to excessive shocks as this may impair its performance or cause breakage or failure.
- Because the desoldering tool is extremely hot during normal use, proper maintenance is essential. Read the "MAINTENANCE" section of these instructions and clean the designated areas and replace parts when necessary.
- Safety considerations. Be very careful when handling the desoldering tool. During operation, the tip of the nozzle will rise to a temperature of 380 – 480°C/715 – 895°F, and the surrounding areas will become extremely hot.
 - After use, remove the cord from the power outlet.
 - Never leave a plugged-in desoldering tool next to flammable materials.
 - Wait until the desoldering tool has cooled completely before putting it away.
 - Never wave or swing the desoldering tool around, as hot solder from the tip may fly off and cause injury.
 - Be especially careful when other people are in the area. Warn them of the danger of being burned by the hot desoldering tool.
- Use only genuine HAKKO 808 replacement parts. The use of other replacement parts may impair performance or cause damage or injury.

If the pump does not operate, immediately clean the nozzle and heater. Replace the filter if necessary. If the pump still does not operate, the motor's thermal protector may have tripped. For safety reasons, the HAKKO 808 motor's thermal protector will trip when the motor exceeds a certain temperature. Once the thermal protector has tripped, it will take about 20 minutes for the motor's temperature to return to a safe level and for the pump to begin operating again. DO NOT cause the thermal protector to trip repeatedly as this may cause damage to the HAKKO 808.

SPECIFICATIONS

Model Name	HAKKO 808
Power Consumption	230V-95W
Heating Element	230V-75W
Motor Output	6.5W
Temperature Range	380 – 480°C/715 – 895°F
Nozzle to Ground Potential	<2mV
Nozzle to Ground Resistance	<2Ω
Vacuum Pump	2-cylinder diaphragm pump
Vacuum Pressure	80kPa (600mmHg)
Suction Flow	10 //minute
Dimensions	170 (H) × 235 (W) mm /6.7 (H) × 9.3 (W) in.
Weight (w/o cord)	420g/0.9lb.
Standard Nozzle	ø1.0 mm/0.04 in. (Part No. A1005)

*Specifications and design are subject to change without notice.

OPERATION

A. Preparation

1. Insert the plug of the power cord into an outlet.
2. Wait about 5 minutes for the nozzle and heating core to heat up.

Even if the tip of the nozzle can melt the solder, the heating core through which the solder passes may not be sufficiently hot. Be sure to wait at least 5 minutes to ensure that the core is hot enough.

B. Desoldering

CAUTION

- If the pump does not operate, immediately clean the nozzle & heating element and replace the filter if necessary.
- Do not remove the pump cover during use. The pump rotates at a high speed and can be dangerous.

1. Place the nozzle over the lead wire of the part to be desoldered and begin heating.

Be careful to heat the lead wire and the solder, not the land. Placing the nozzle directly in contact with the land may cause the land to peel off.

2. Check to make sure all of the solder on the joint has melted.

With the nozzle still in place over the lead wire, slowly move the lead wire, being careful not to apply too much force. If the lead wire moves easily, all of the solder has melted.

3. Pull the trigger to remove the melted solder.

Make sure that a filter has been inserted in the desoldering tool. Desoldering without a filter may damage the pump.

4. If you make a mistake, re-solder the part using new solder and then repeat the desoldering process.

C. Cleaning

Cleaning is extremely important and should be done frequently during the desoldering process. Parts should be checked periodically for wear and should be replaced if necessary. See the MAINTANCE section of these instructions.

- Clean the nozzle as you would clean a soldering tip: wipe away any solder scraps with a sponge moistened with water. Before putting the desoldering tool away, apply a new coat of solder on the tip.
- Using a cleaning pin that matches the diameter of the nozzle, clean the inside of the nozzle aperture. This must be done while the nozzle and heating core are still hot, so be careful.
- Discard any solder that has collected in the filter pipe. Do this carefully, as the solder will still be extremely hot.
- Replace the filter. See the MAINTANCE section of these instructions.

The ceramic paper filter (L) should be replaced immediately when it becomes worn. Failure to do this will reduce the performance of the pump and may damage it.

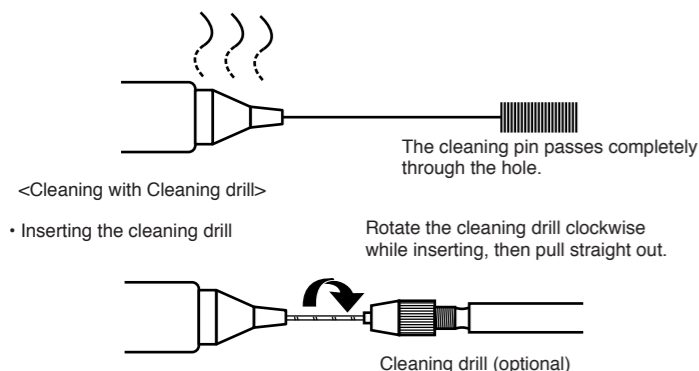

D. Temperature setting

The temperature of the HAKKO 808 can be adjusted between 380 – 480°C/715 - 895°F. Set the temperature in accordance with the requirements of the job being done. Although the temperature needed for desoldering cannot be determined merely by the type of board to be desoldered, the values in the table below may be used as a general guide:

CAUTION

- Change the temperature *only* with the "TEMP" trim pot. Do not use the "CAL" pot.

Type of board	Approximate setting (on scale)
Single-sided P.W.B.	1 ~ 2
Through-hole P.W.B.	3 ~ 4
Multilayer P.W.B.	5

- In general, the greater the temperature, the more quickly the nozzle will wear out.
- As nozzle wear increases, the nozzle temperature will decrease. In such cases, increasing the set temperature will only hasten wear. Replace worn nozzles as soon as possible.

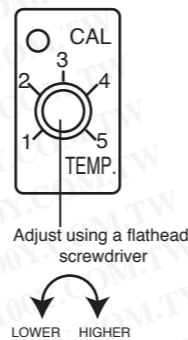

MAINTENANCE

The frequency of cleaning and part replacement greatly depends on a variety of factors, including the temperature at which the desoldering tool is operated, and the types of solder and flux used. Using the table below as a general guide, clean and replace parts in accordance with use conditions.

	Maintenance
During use	Clean nozzle Discard solder that has collected Clean nozzle and heating core
When necessary	Replace parts

CAUTION

- If the power cord is damaged, it must be replaced by the manufacturer, its service agent or similarly qualified person in order to avoid personal injury or damage to the unit.

A. A general guide to replacement part

Use the table below as a general guide to replacement part. Use only genuine HAKKO 808 replacement parts as the use of other parts may impair performance, or cause damage or injury.

Part Name	Signs that replacement is needed
Pre-filter	Cannot hold solder Warping
Ceramic paper filter (L)	Hardened by flux staining
Front holder	Hole has become enlarged Hardening has reduced air tightness
Filter holder	Hardening had reduced air tightness
Nozzle	Repels solder Solder plating on tip is gone Clogging Hole has corroded and is larger Temperature is low
Heating core (in heater)	Clogged At 23°C/73°F, Normal heater resistance value is 40Ω – 50Ω (100 – 120V models) 210Ω – 270Ω (220 – 240V models)

B. Cleaning and replacing parts

● Nozzle and heating element (heater core)

NOTE: Be careful since the areas around the nozzle and heating element are very hot.

1. Loosen the cap nut with the attached spanner and remove the protective pipe and the nozzle.

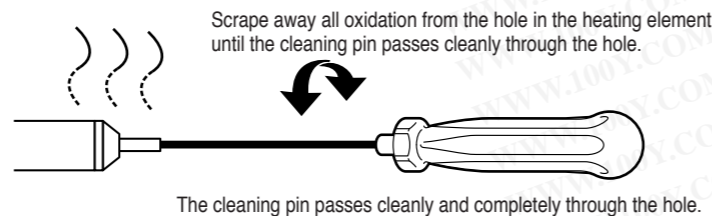

● Around the filter pipe

Be careful since the area around the filter pipe is extremely hot.

1. Pull the rear holder back and remove the filter pipe.

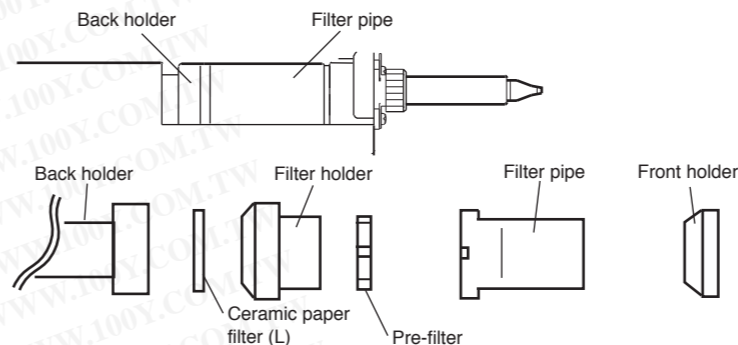

2. Inspect the filter and holder.
3. During assembly, be sure to insert the filter. Failure to do so may damage the unit.

NOTE:

When suction force is still weak even after cleaning and replacing parts of "Nozzle and heating element (heater core)" and "Filter pipe", the pump maintenance or pump repair is needed. Contact HAKKO sales outlet or HAKKO dealer.

● Replacing the heating element (heating core)

By grasping the plug, remove the power plug from the outlet and wait until the unit has cooled completely.

1. Remove the cap nut with the attached spanner and remove the filter pipe and front holder.
2. Remove the 3 screws at the base of the heating element (heating core).
3. Loosen the screws and remove the pump cover.
4. Remove the 3 screws holding on the housing and remove the housing.

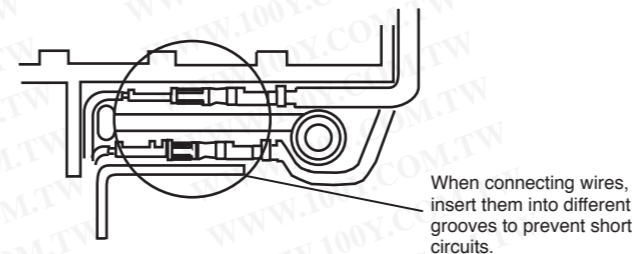

5. Disconnect the terminals and replace the heating element.
 6. Assemble using the same procedure in reverse.
 7. Calibrate the temperature.
- Be sure to calibrate the temperature after replacing the heating element. Failure to do this may result in a heater temperature value that is higher or lower than that of the old one.

C. Calibrating the temperature

1. Replace with a new nozzle. The nozzle being used may have already started to wear, so use a new nozzle.
 2. Insert the power plug into the outlet.
 3. Set the temperature to the maximum value possible.
 4. Wait 5 minutes.
 5. Use a soldering iron tip thermometer to measure the temperature at the tip of the nozzle. Do not apply suction, as this will cause the temperature to drop.
 6. Adjust CAL until the temperature is 480°C/895°F. Turn CAL clockwise to increase the temperature.
- It may take several minutes for the nozzle temperature to stabilize after CAL is adjusted.
 - During CAL adjustment, make sure the set temperature does not go above 480°C/895°F, as this may damage the desoldering tool.

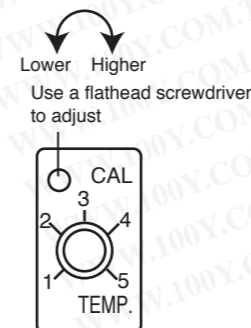

TROUBLESHOOTING

	Problem cause	Procedure
Tool does not heat up	Tool is not connected properly to power outlet	Connect properly
	Heating element burnout	Replace heating element
Temperature is low	Temperature is set too low	Reset
	Temperature has not been calibrated properly	Calibrate properly
Pump does not operate	Nozzle is worn out	Replace nozzle
	Nozzle or heating core (in heating element) is clogged	Clean
Suction force is weak	Too much solder or flux has collected in the filter	Replace filter
	Air leakage	Inspect nozzle, area around filter and pump hose
	Pump valve or diaphragm is broken	Replace valve or diaphragm

NOTE:

Use of the tool when the nozzle, heating core, or filter is clogged may cause the pump to lock up and render operation impossible. Clean or otherwise eliminate the blockage before attempting to use the tool.

Repairs

When repair becomes necessary, check the following and then bring the desoldering tool to a HAKKO sales outlet or HAKKO dealer.

1. Is the nozzle or heating core clogged?
2. Is the valve plate cracked or missing?
3. Is the front holder or filter holder warped or cracked?
4. Is the pre-filter or ceramic paper filter dirty or warped?

勝特力材料 886-3-5753170
 胜特力电子(上海) 86-21-54151736
 胜特力电子(深圳) 86-755-83298787
[Http://www.100y.com.tw](http://www.100y.com.tw)

HAKKO
HAKKO CORPORATION
 HEAD OFFICE
 4-5, SHIOKUSA 2-CHOME, NANIWA-KU, OSAKA,
 556-0024 JAPAN
 TEL:+81-6-6561-3225 FAX:+81-6-6561-8466
<http://www.hakko.com>

2005.9
 MA00055XZ050902

Copyright © 2004 HAKKO Corporation. All Rights Reserved.