

Color sensor

S11059-01WT

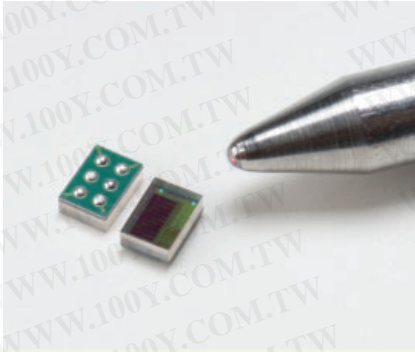

I²C interface-compatible color sensor

The S11059-01WT is a color sensor that supports the I²C (inter-integrated circuit) interface. It is sensitive to red ($\lambda=615$ nm), green ($\lambda=530$ nm), blue ($\lambda=460$ nm), and infrared ($\lambda=855$ nm) light, and outputs detected results as 16-bit digital data for each color. The photodiode for each color is automatically switched sequentially to perform measurements. The sensitivity and integration time can be adjusted so that light measurements can be performed over a wide range.

Features

- I²C interface compatible
- Sequential measurements of red, green, blue, and infrared light
- 2-step sensitivity switching (sensitivity ratio 1 : 10)
- Sensitivity adjustment by setting the integration time
- Low voltage (2.5 V or 3.3 V) operation
- Low current consumption: 75 μ A typ.
- Small package (WL-CSP: wafer level-chip size package)
- Internal infrared-cut filter
- Wide dynamic range (Low gain: 1 to 10 k/x)

Feature 01 I²C interface-compatible to allow direct connection to micro-controller

The sensor supports the I²C interface and so can exchange data with the micro-controller using two signal lines jointly usable with other devices. The digital output makes it easy to install into electronic devices such as cell phones and flat-panel TVs whose micro-controller is compatible with the I²C interface. The sensor supports I²C Fast mode (400 kHz) and operates on 2.25 to 3.63 V.

Applications

- LCD backlight adjustment for cell phones, notebook PC, etc.
- Energy-saving sensor for large-size TV, etc.
- Various types of light detection or color adjustment

Feature 02 WL-CSP makes the device even smaller and highly reliable

The WL-CSP measures only $1.18 \times 1.68 \times 0.58$ mm and lead-free reflow solder (260 °C) can be used.

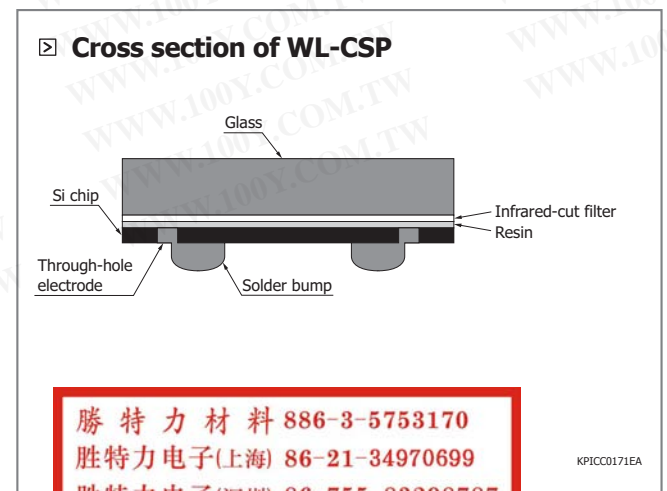
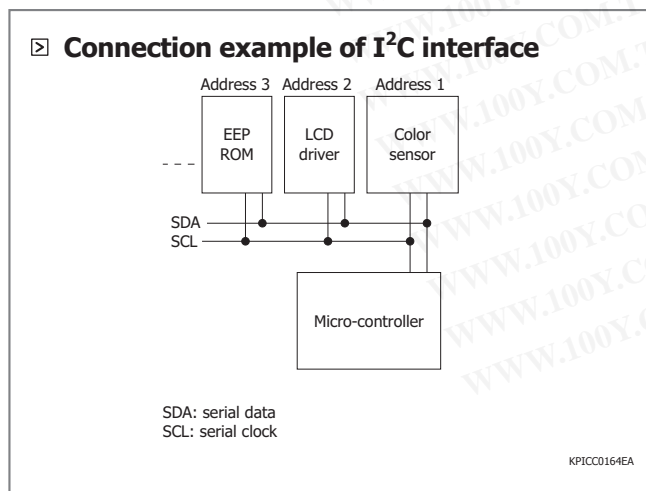

勝特力材料 886-3-5753170
 勝特力电子(上海) 86-21-34970699
 勝特力电子(深圳) 86-755-83298787
[Http://www.100y.com.tw](http://www.100y.com.tw)

■ Absolute maximum ratings (Ta=25 °C)

Parameter	Symbol	Value	Unit
Supply voltage	Vdd	-0.3 to +6	V
Load current	Io	±10	mA
Power dissipation	P	100	mW
Operating temperature	Topr	-40 to +85	°C
Storage temperature	Tstg	-40 to +100	°C
Reflow soldering conditions *1	Tsol	Peak temperature 260 °C, 3 times	-

*1: Moisture absorption and reflow conditions: JEDEC J-STD-020D LEVEL2a

■ Recommended operating conditions

Parameter	Symbol	Condition	Min.	Typ.	Max.	Unit
Supply voltage	Vdd		2.25	-	3.63	V
I ² C bus pull-up voltage	Vbus	Rp *2=2.2 kΩ	1.65	-	Vdd + 0.5	V
High level input voltage (SDA, SCL)	Vih	Vbus ≥ 2.25 V, Vdd > 2.75 V	0.7Vbus	-	Vdd + 0.5	V
		Vbus < 2.25 V, Vdd ≤ 2.75 V	0.8Vbus	-	Vdd + 0.5	
Low level input voltage (SDA, SCL)	Vil	Vbus ≥ 2.25 V, Vdd > 2.75 V	-0.5	-	0.2Vbus	V
		Vbus < 2.25 V, Vdd ≤ 2.75 V	-0.5	-	0.3Vbus	
Bus capacitance (SDA, SCL)	Cbus		-	-	400	pF

*2: Pull-up resistor value is determined by Cbus and Vbus.

■ Electrical and optical characteristics

■ Sensor section [Ta=25 °C, Vdd=3.3 V, A light source, unless otherwise noted (initial setting: low gain, integration time: 546 ms/ch)]

Parameter	Symbol	Condition	Min.	Typ.	Max.	Unit			
Spectral response range *3	λ	Blue		400 to 540		nm			
		Green		455 to 630					
		Red		575 to 660					
		Infrared, more than 700 nm		785 to 885					
Peak sensitivity wavelength	λp	Blue	-	460	-	nm			
		Green	-	530	-				
		Red	-	615	-				
		Infrared, more than 700 nm	-	855	-				
Current consumption	Operating mode	Idd	E=0 lx (dark state), excluding output current	30	75	150	μA		
	Standby mode	Idds		0.1	1.0	3.0			
Dark count	Sd	E=0 lx (dark state)	-	-	5	counts			
Gain ratio	rg	High gain/Low gain	-	10	-	-			
Photo sensitivity	Low gain	Sbl	Blue	Initial setting	2.01	3.35	4.69	counts/lx	
		Sgl	Green		4.57	7.61	10.66		
		Srl	Red		5.69	9.48	13.28		
		Sirl	Infrared		-	1.66	-		
		Sbl	Blue		Initial setting *4	2.51	3.35		4.19
		Sgl	Green			5.71	7.61		9.52
		Srl	Red			7.11	9.48		11.85
		Sirl	Infrared			-	1.66		-
Red/Blue sensi. ratio	Low gain	Sr/Sbl	Initial setting Same chip	2.12	2.83	3.54	-		
Red/Green sensi. ratio		Sr/Sgl		0.93	1.25	1.56			
Blue/Green sensi. ratio		Sbl/Sgl		0.33	0.44	0.55			
Photo sensitivity	High gain	Sbh	Blue	Integration time: 546 ms/ch	19.0	31.7	44.4	counts/lx	
		Sgh	Green		45.7	76.2	106.7		
		Srh	Red		56.7	94.5	132.4		
		Sirh	Infrared		-	15.3	-		
		Sbh	Blue	Integration time: 546 ms/ch *4	23.8	31.7	39.7		
		Sgh	Green		57.2	76.2	95.3		
		Srh	Red		70.9	94.5	118.2		
		Sirh	Infrared		-	15.3	-		
Red/Blue sensi. ratio	High gain	Srh/Sbh	Integration time: 546 ms/ch Same chip	2.24	2.98	3.73	-		
Red/Green sensi. ratio		Srh/Sgh		0.93	1.24	1.55			
Blue/Green sensi. ratio		Sbh/Sgh		0.31	0.42	0.52			

*3: Relative sensitivity=more than 10%

*4: Integration time is measured and corrected. See "Compensation method for sensitivity variation". Integration time measurement accuracy is 0.36%.

■ I²C section (Ta=25 °C, Vdd=3.3 V, unless otherwise noted)

Parameter	Symbol	Condition	Min.	Typ.	Max.	Unit
I ² C address	ADDR	7 bits		0x2A (0101010)		
I ² C clock frequency	fclk		1	-	400	kHz
SDA, SCL output voltage	High level	Voh	Rp=2.2 kΩ	0.7Vbus	-	V
	Low level	Vol	Rp=2.2 kΩ	0	0.4	V
Input/output terminal capacitance	Ci		-	-	20	pF
SDA/SCL output fall time *5	tf	Rp=2.2 kΩ, Cp=400 pF	-	-	250	ns

*5: SCL/SDA output rise time is determined by a time constant of Cbus × Rp.

Note: The I²C interface (SDA, SCL) timings conform to the "I²C bus specification version 2.1".

Register map

Adrs	Function	bit								
		7	6	5	4	3	2	1	0	
00	Control	ADC reset 1: Reset 0: Operation	Standby function 1: Standby mode 0: Operating mode	Standby function monitor	-	Gain selection 1: High gain 0: Low gain	Integration mode 1: Manual setting mode 0: Fixed period mode	Integration time setting (00) 87.5 μs, (01) 1.4 ms (10) 22.4 ms, (11) 179.2 ms		
01	Manual timing register	Integration time manual setting register (MSB)								
02		Integration time manual setting register (LSB)								
03	Sensor data register (red)	Output data (red, MSB)								
04	Sensor data register (green)	Output data (red, LSB)								
05	Sensor data register (green)	Output data (green, MSB)								
06	Sensor data register (blue)	Output data (green, LSB)								
07	Sensor data register (blue)	Output data (blue, MSB)								
08	Sensor data register (infrared)	Output data (blue, LSB)								
09	Sensor data register (infrared)	Output data (infrared, MSB)								
0A	Sensor data register (infrared)	Output data (infrared, LSB)								

Adrs 00 bit 7: Asserting this bit to "1", the ADC block is reset. The register data is not reset. To start the operation, set this bit to "0".

Adrs 00 bit 6: Asserting this bit to "1" the device goes into standby mode. The ADC block stops its operation. The register data is not reset. To start the operation, set this bit to "0".

Adrs 00 bit 5: This monitors auto standby function. "1" means standby mode. This is read only.

Adrs 00 bit 3: Gain selection bit. "1" is high gain mode and "0" is low gain mode. This bit is selecting the photodiode area. The size ratio of high gain photodiode area and low gain photodiode area is 10 : 1. Therefore the gain ratio is 10 times from low to high.

Adrs 00 bit 2: Asserting this bit to "1", the device goes into manual setting mode. Deasserting this bit to 0, goes into fixed period mode. In manual setting mode, the S11059-01WT automatically goes to standby mode after a measurement is made. In fixed period mode, measurements are continuously repeated.

Adrs 00 bit 1,0: These bits select the period of internal basis clock. The period is equal to integration time per color in fixed period mode. "00" is 87.5 μs, "01" is 1.4 ms, "10" is 22.4 ms, "11" is 179.2 ms. In manual setting mode, "00" is 175 μs, "01" is 2.8 ms, "10" is 44.8 ms, "11" is 368 ms. The integration time per color is set to multiple value (Adrs 01 & 02) with the period.

Adrs 01 & 02: This is a multiple value setting in manual setting mode, and can be set to a minimum of 0x0000 and a maximum of 0xFFFF (65535). This is used to set how far to expand the integration time per color which specified by "Integration time setting" (Tint). For example, if you want to set the integration time per color to 546 ms, set 175 μs by Tint="00" and then set this register to N=3120 (0xC30).

Mode	Manual timing register (Adrs 01 & 02)	Integration time setting (Tint)			
		00	01	10	11
Fixed period mode	Disabled	87.5 μs	1.4 ms	22.4 ms	179.2 ms
Manual setting mode	N	175 × N μs	2.8 × N ms	44.8 × N ms	358.4 × N ms

Adrs 03 to 0A: These bytes are register for sensor data. S11059-01WT measurement result is stored in these registers when the I²C command is changed to read mode. The values are kept until next read cycle.

Initial setting [Low gain, manual setting mode, Tint=00 (175 μs), integration time 546 ms/ch]

Adrs	Function	bit								Hex
		7	6	5	4	3	2	1	0	
00	Control	1	1	1	-	0	1	0	0	0xE4
01	Manual timing register	0	0	0	0	1	1	0	0	0x0C
02		0	0	1	1	0	0	0	0	0x30

Program example

Condition 1: Initial setting [manual setting mode, low gain, Tint=00 (175 μs), integration time 546 ms/ch (0x0C30 is set in manual timing register)]

Command

Action		Data body								Ack	Remark	
Address call (0x2A)	S	0	1	0	1	0	1	0	0	W	A	7-bit address
Register call (0x00)		0	0	0	0	0	0	0	0	0	A	Calls control byte
Register write (0x84)		1	0	0	0	0	1	0	0	0	A	ADC reset, standby disabled
Address call (0x2A)	Sr	0	1	0	1	0	1	0	0	W	A	Restart, address
Register call (0x00)		0	0	0	0	0	0	0	0	0	A	Calls control byte
Register write (0x04)		0	0	0	0	0	1	0	0	0	A	P ADC reset disabled, bus release
Wait longer than integration time (>2184 ms)												
Address call (0x2A)	S	0	1	0	1	0	1	0	0	W	A	7-bit address
Register call (0x03)		0	0	0	0	0	0	1	1	1	A	Calls output data byte
Address call (0x2A)	Sr	0	1	0	1	0	1	0	0	R	A	Changes to read mode
Data read out (R: MSB)		X	X	X	X	X	X	X	X	X	A	Red data output
Data read out (R: LSB)		X	X	X	X	X	X	X	X	X	A	
Data read out (G: MSB)		X	X	X	X	X	X	X	X	X	A	Green data output
Data read out (G: LSB)		X	X	X	X	X	X	X	X	X	A	
Data read out (B: MSB)		X	X	X	X	X	X	X	X	X	A	Blue data output
Data read out (B: LSB)		X	X	X	X	X	X	X	X	X	A	
Data read out (Infrared: MSB)		X	X	X	X	X	X	X	X	X	A	Infrared data output
Data read out (Infrared: LSB)		X	X	X	X	X	X	X	X	X	A	

S=Start condition, Sr=Restart condition, A=Acknowledge, A=Acknowledge by host, P=Stop condition, R=Read mode (1), W=Write mode (0), \bar{A} =not acknowledge

Format



Wait

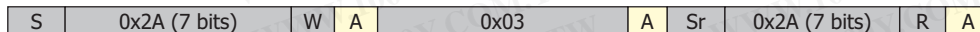

from master to slave

from slave to master

Condition 2 [fixed period mode, high gain, Tint=01 (1.4 ms), integration time 1.4 ms/ch]

■ Command

Action		Data body								Ack	Remark
Address call (0x2A)	S	0	1	0	1	0	1	0	W	A	7-bit address
Register call (0x00)		0	0	0	0	0	0	0	0	A	Calls control byte
Register write (0x89)		1	0	0	0	1	0	0	1	A	ADC reset, standby disabled
Address call (0x2A)	Sr	0	1	0	1	0	1	0	W	A	7-bit address
Register call (0x00)		0	0	0	0	0	0	0	0	A	Calls control byte
Resistor write (0x09)		0	0	0	0	1	0	0	1	A	P ADC reset disabled, bus release
Wait longer than integration time (> 5.6 ms). Within this period, repeat measurement is continued.											
Address call (0x2A)	S	0	1	0	1	0	1	0	W	A	7-bit address
Register call (0x03)		0	0	0	0	0	0	1	1	A	Calls output data byte
Address call (0x2A)	Sr	0	1	0	1	0	1	0	R	A	Changes to read mode
Data read out (R: MSB)		X	X	X	X	X	X	X	X	A	Red data output
Data read out (R: LSB)		X	X	X	X	X	X	X	X	A	
Data read out (G: MSB)		X	X	X	X	X	X	X	X	A	Green data output
Data read out (G: LSB)		X	X	X	X	X	X	X	X	A	
Data read out (B: MSB)		X	X	X	X	X	X	X	X	A	Blue data output
Data read out (B: LSB)		X	X	X	X	X	X	X	X	A	
Data read out (Infrared: MSB)		X	X	X	X	X	X	X	X	A	Infrared data output
Data read out (Infrared: LSB)		X	X	X	X	X	X	X	X	\bar{A}	P

S=Start condition, Sr=Restart condition, A=Acknowledge, \bar{A} =Acknowledge by host, P=Stop condition, R=Read mode(1), W=Write mode(0), \bar{A} =not acknowledge

■ Format

S	0x2A (7 bits)	W	A	0x00	A	0x89	A
---	---------------	---	---	------	---	------	---

Sr	0x2A (7 bits)	W	A	0x00	A	0x09	A	P
----	---------------	---	---	------	---	------	---	---

Wait

S	0x2A (7 bits)	W	A	0x03	A	Sr	0x2A (7 bits)	R	A
---	---------------	---	---	------	---	----	---------------	---	---

Sensor data	A	Sensor data	A
-------------	---	-------------	---

Sensor data	A	Sensor data	A
-------------	---	-------------	---

Sensor data	A	Sensor data	A
-------------	---	-------------	---

Sensor data	A	Sensor data	\bar{A}	P
-------------	---	-------------	-----------	---

from master to slave

from slave to master

■ Compensation method for sensitivity variation

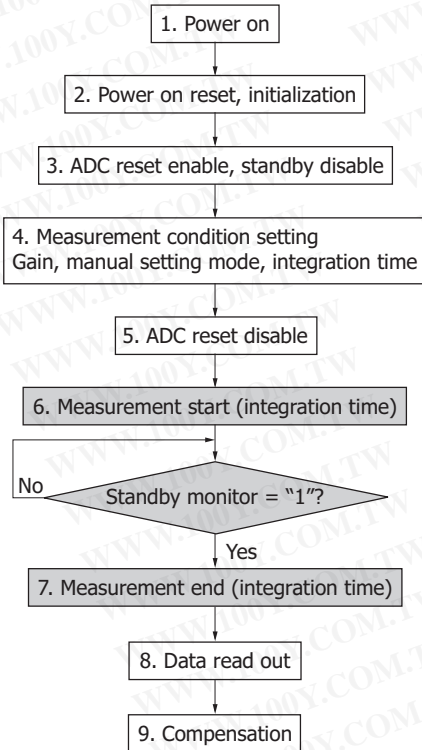

Sensitivity variation can be decreased using the compensation coefficient which is calculated from the integration time measurement result. Explanation of compensation method is shown as follows.

■ Integration time measurement method

In case of integration time measurement, it is necessary to set manual setting mode. The integration time measurement starts after "ADC reset" disabled. To measure the finishing integration time (measurement) T_{meas}, check "Standby monitor" bit until it becomes to "1".

■ Compensation method

The sensitivity compensation that used integration time is as follows:

$$K = \frac{T_{set}}{T_{meas}}$$

$$S' = S \cdot K$$

- K : compensation coefficient
- T_{set} : integration time (setting)
- T_{meas}: integration time (measurement)
- S : photo sensitivity (measurement)
- S' : photo sensitivity (compensation)

■ Measurement accuracy of integration time

The measurement minimum resolution of T_{meas} is defined by the looping duration (T_{unit}). In case of default setting, the T_{set} is 2184 ms and assuming the T_{unit} to 7.8 ms, the accuracy of integration time is calculated by following formula.

$$\frac{T_{unit}}{T_{set}} \times 100 = \frac{7.8}{2184} \times 100 = 0.36\%$$

The specification of compensated sensitivity is defined as 0.36% accuracy.

■ Spectral response

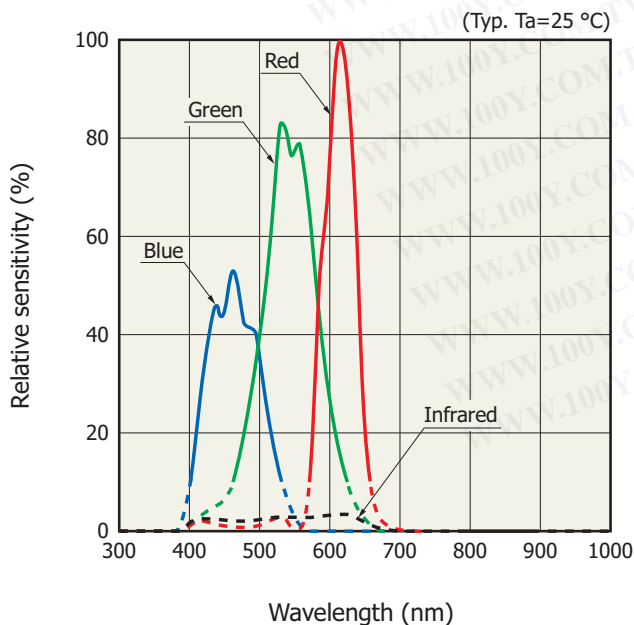

■ Count value vs. illuminance (typical example)

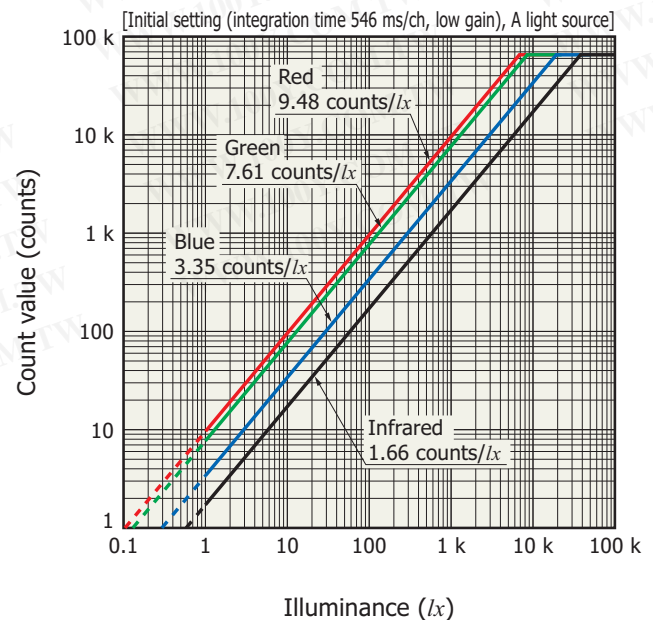

Block diagram

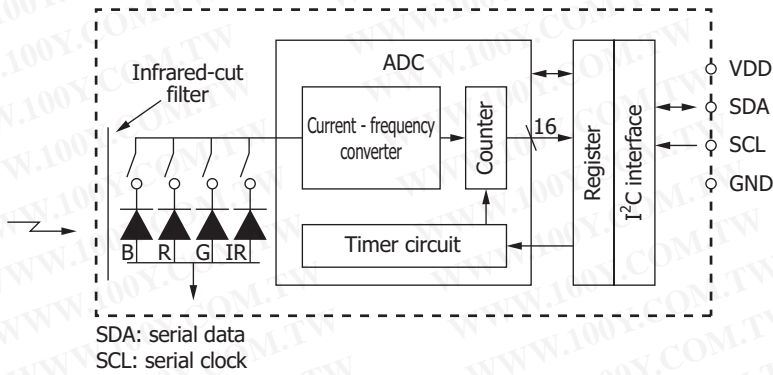

勝特力材料 886-3-5753170
 勝特力电子(上海) 86-21-34970699
 勝特力电子(深圳) 86-755-83298787
[Http://www.100y.com.tw](http://www.100y.com.tw)

Details of active area (unit: μm)

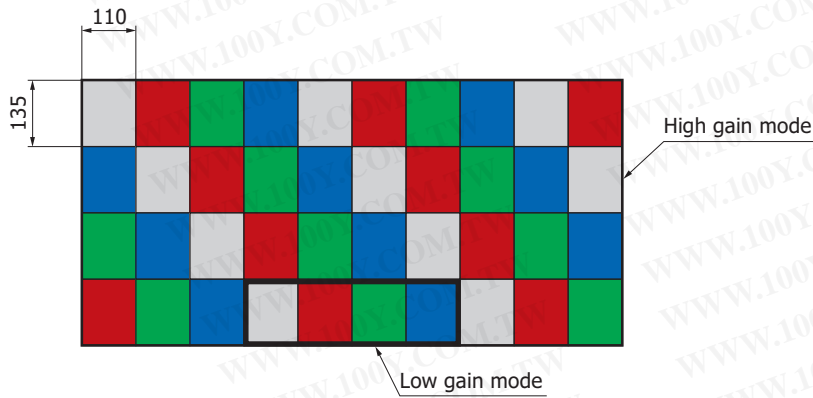

Timing chart of standby function

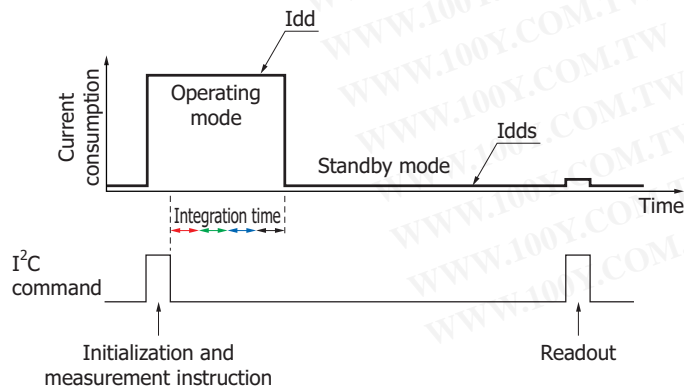

Connection example

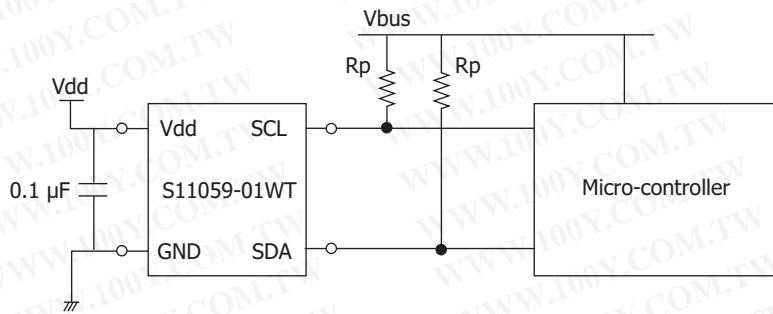

KPIC0174EC

勝特力材料 886-3-5753170
 勝特力电子(上海) 86-21-34970699
 勝特力电子(深圳) 86-755-83298787
[Http://www.100y.com.tw](http://www.100y.com.tw)

Dimensional outline (unit: mm)

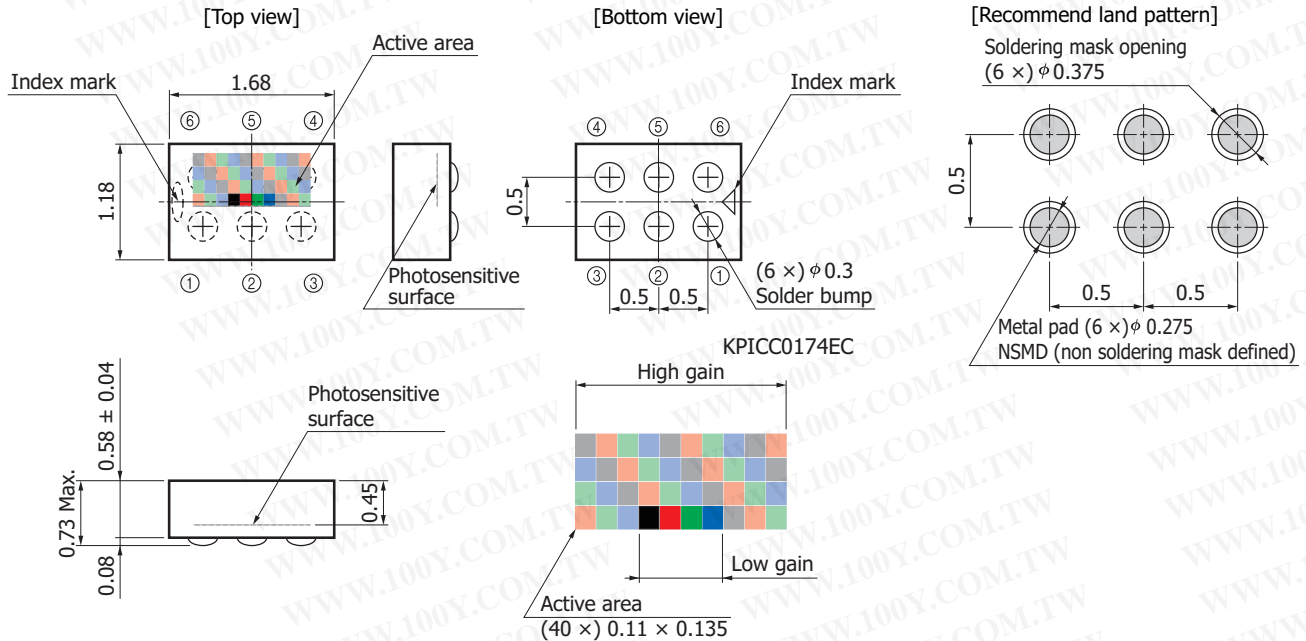

- ① Vdd
- ② NC
- ③ GND
- ④ SCL
- ⑤ NC
- ⑥ SDA













Tolerance unless
 otherwise noted: ± 0.05
 Packing: reel (3000 pcs/reel)

■ Active area for infrared detection

KPICA0081EB

Note: When using this product, please request our technical information (S11059 series) and ensure appropriate design according to the information.

Line-up of RGB color sensors

Type No.	Type	Active area size (mm)	Package (mm)	Peak sensitivity wavelength (nm)	Photo sensitivity				Photo							
S9032-02	Photodiode	 $\phi 2.0$	4 × 4.8 × 1.8 ^t 6-pin (filter 0.75 ^t)	B	460	B	0.18 (A/W) [$\lambda=460$ nm]									
				G	540	G	0.23 (A/W) [$\lambda=540$ nm]									
				R	620	R	0.16 (A/W) [$\lambda=620$ nm]									
S9702	Photodiode	 1.0 × 1.0	3 × 4 × 1.3 ^t 4-pin (filter 0.75 ^t)	B	460	B	0.18 (A/W) [$\lambda=460$ nm]									
				G	540	G	0.23 (A/W) [$\lambda=540$ nm]									
				R	620	R	0.16 (A/W) [$\lambda=620$ nm]									
S10917-35GT	Photodiode	 1.0 × 1.0	3 × 1.6 × 1.0 ^t COB (on-chip filter)	B	460	B	0.2 (A/W) [$\lambda=460$ nm]									
				G	540	G	0.23 (A/W) [$\lambda=540$ nm]									
				R	620	R	0.17 (A/W) [$\lambda=620$ nm]									
S10942-01CT	Photodiode	 1.0 × 1.0	3 × 1.6 × 1.0 ^t COB (on-chip filter)	*6		B	0.21 (A/W) [$\lambda=460$ nm]									
						G	0.25 (A/W) [$\lambda=540$ nm]									
						R	0.45 (A/W) [$\lambda=640$ nm]									
S9706	Digital Photo IC	 1.2 × 1.2	4 × 4.8 × 1.8 ^t 6-pin (filter 0.75 ^t)	B	465	Low	B	0.21 (LSB/lx)	High	B	1.9 (LSB/lx)					
				G	540		G	0.45 (LSB/lx)		G	4.1 (LSB/lx)					
				R	615		R	0.64 (LSB/lx)		R	5.8 (LSB/lx)					
S11059-01WT	I ² C interface- compatible color sensor	 1.22 × 0.56	1.68 × 1.18 × 0.58 ^t WL-CSP (on-chip filter)	B	460	Low	B	3.35 (counts/lx)	High	B	31.7 (counts/lx)					
				G	530		G	7.61 (counts/lx)		G	76.2 (counts/lx)					
				R	615		R	9.48 (counts/lx)		R	94.5 (counts/lx)					
				IR	855		IR	1.66 (counts/lx)		IR	15.3 (counts/lx)					

*6: Refer to "Spectral response" of "Si photodiode S10942-01CT" datasheet.

勝特力材料 886-3-5753170
 勝特力电子(上海) 86-21-34970699
 勝特力电子(深圳) 86-755-83298787
[Http://www.100y.com.tw](http://www.100y.com.tw)

Information described in this material is current as of January, 2011. Product specifications are subject to change without prior notice due to improvements or other reasons. Before assembly into final products, please contact us for the delivery specification sheet to check the latest information.

Type numbers of products listed in the delivery specification sheets or supplied as samples may have a suffix "(X)" which means preliminary specifications or a suffix "(Z)" which means developmental specifications.

The product warranty is valid for one year after delivery and is limited to product repair or replacement for defects discovered and reported to us within that one year period. However, even if within the warranty period we accept absolutely no liability for any loss caused by natural disasters or improper product use.

Copying or reprinting the contents described in this material in whole or in part is prohibited without our prior permission.

HAMAMATSU

www.hamamatsu.com

HAMAMATSU PHOTONICS K.K., Solid State Division

1126-1 Ichino-cho, Higashi-ku, Hamamatsu City, 435-8558 Japan, Telephone: (81) 53-434-3311, Fax: (81) 53-434-5184

U.S.A.: Hamamatsu Corporation: 360 Foothill Road, P.O.Box 6910, Bridgewater, N.J. 08807-0910, U.S.A., Telephone: (1) 908-231-0960, Fax: (1) 908-231-1218

Germany: Hamamatsu Photonics Deutschland GmbH: Arzbergerstr. 10, D-82211 Herrsching am Ammersee, Germany, Telephone: (49) 8152-375-0, Fax: (49) 8152-265-8

France: Hamamatsu Photonics France S.A.R.L.: 19, Rue du Saule Trapu, Parc du Moulin de Massy, 91882 Massy Cedex, France, Telephone: 33-(1) 69 53 71 00, Fax: 33-(1) 69 53 71 10

United Kingdom: Hamamatsu Photonics UK Limited: 2 Howard Court, 10 Tewin Road, Welwyn Garden City, Hertfordshire AL7 1BW, United Kingdom, Telephone: (44) 1707-294888, Fax: (44) 1707-325777

North Europe: Hamamatsu Photonics Norden AB: Smidesvägen 12, SE-171 41 Solna, Sweden, Telephone: (46) 8-509-031-00, Fax: (46) 8-509-031-01

Italy: Hamamatsu Photonics Italia S.R.L.: Strada della Moia, 1 int. 6, 20020 Arese, (Milano), Italy, Telephone: (39) 02-935-81-733, Fax: (39) 02-935-81-741