

# INDEX

**R**eliability 信任  
**i**nnovation 創新  
**K**nowledge 精通  
**O**riginality 獨創

## Photo / Area Photo / Ultrasonic Sensor 光電 / 光柵 / 超音波

接線圖 .....	16
選型指南 .....	19

### Long Sensing Range Photo Sensor 長距離檢測方型光電

R5JM .....	20
R3JK .....	21

### Laser Photo Sensor 雷射光電感測器

LK .....	24
LRS .....	28

### Miniature Photo Sensor 光電開關

PK3 .....	29
PKG3 .....	34
PK5 .....	35
PM6 .....	36

### Superior Waterproof T-style Photo Sensor 高防水性 T型光電

PTQ18 .....	37
-------------	----

### Tubular Photo Sensor 圓管型光電

RMF .....	39
MMF .....	42

### U-shape Photo Sensor U型光電開關

SU07 .....	44
SU .....	46
SU18 .....	47
SU30 .....	48

### Micro Photo Sensor 光電素子

SPR .....	51
RX .....	52

### General Purpose Compact Area Sensor 光柵

OAP .....	56
ASP .....	64

### Ultrasonic Sensor 超音波開關

RU18 .....	75
------------	----

## Inductive / Capacitive Proximity Sensor 電感式 / 靜電容

接線圖 .....	87
-----------	----

### Tubular Inductive Proximity Sensor 圓管型近接開關

選型指南 .....	88
Ø3 .....	89
Ø4 .....	90
M5 .....	91
Ø6 .....	92
M8 .....	93
M12 .....	96
M18 .....	102
M30 .....	108
注意事項 .....	114

### Rectangular Inductive Proximity Sensor 方型近接開關

選型指南 .....	117
JM/JMD .....	118
JN/JND .....	120
KND .....	122
PN .....	123
PND .....	126
RN .....	128
SN .....	130

### Inductive Ring Sensor 環型近接開關

SID .....	136
SIR .....	138
SIA .....	140

### Capacitive Proximity Sensor 靜電容式近接開關

KC .....	144
KCT .....	147
KCP .....	148

## Others 其它

### Controller 控制器

ST-1 .....	151
ST-T2 .....	151

### Rechargeable Multi-function Sensor Tester 可充電式多功能測試器

ST-7 .....	153
------------	-----

### Accessories 配件

固定架 .....	154
鏡片 .....	156
接頭線 .....	157
多功能固定架 .....	159

勝特力電材超市-龍山店 886-3-5773766  
勝特力電材超市-光復店 886-3-5729570  
勝特力電子(上海) 86-21-34970699  
勝特力電子(深圳) 86-755-83298787  
<http://www.100y.com.tw>

# Photo / Area Photo / Ultrasonic Sensor

# 光電 / 光柵 / 超音波

Application  
應用例 3

Wiring diagrams  
接線圖 16

OPTIONS  
選型指南 19

Long Sensing Range Photo Sensor  
長距離檢測方型光電 R5JM 20  
R3JK 21

Laser Photo Sensor  
雷射光電感測器 LK 24  
LRS 28

Miniature Photo Sensor  
光電開關 PK3 29  
PKG3 34  
PK5 35  
PM6 36

Superior Waterproof T-style Photo Sensor  
高防水性 T型光電 PTQ18 37

Tubular Photo Sensor  
圓管型光電 RMF 39  
MMF 42

U-shape Photo Sensor  
U型光電開關 SU07 44  
SU 46  
SU18 47  
SU30 48

Micro Photo Sensor  
光電素子 SPR 51  
RX 52

General Purpose Compact Area Sensor  
光柵 OAP 56  
ASP 64

Ultrasonic Sensor  
超音波開關 RU18 75

## P001 滑軌上極限定位檢知 / Detect positions or rails.

53 / 52頁

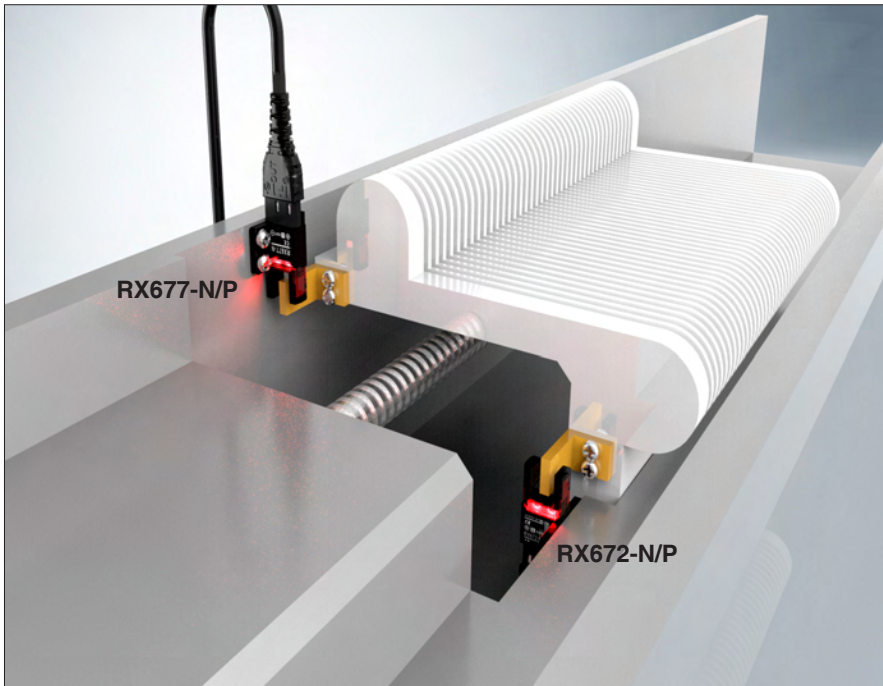

### 型號 / Model

**RX677-N/P / RX672-N/P**

### 檢知條件 / Application

不透光檔片金屬、塑料皆可，選用尺寸建議2x6mm以上檔片。

Metal iron detection, Non-transparent sheet metal, plastic, size of 2x6mm or more.

### 產品特性 / Features

RX系列光電素子，相容於國際標準固定孔位尺寸，U型溝槽寬幅6mm，增加產品的穩定性，防干擾電路設計，本體一體成型，可減少因環境的油汙、震動造成的誤動作。

RX-series photo sensor, compatible with international Standard fixed hole size, U-shaped groove width 6mm, integrated molding Body, can reduce oil pollution and vibration due to the environment to resulting malfunction.

光電/光柵/超音波感測器

電感式/靜電容近接開關

## P002 保特瓶瓶蓋漏鎖檢知 / Detecting presence of cap.

35頁



### 型號 / Model

**PK5-F05N/P**

### 檢知條件 / Application

標準塑膠瓶蓋，直徑28 mm，各式顏色檢知容易。

Cap detection, plastic caps, 28 mm in diameter, each Color detection is easy.

### 產品特性 / Features

PK5-F05N扁平式本體3.5x15x20mm可裝設於小空間，加上聚焦鏡頭，有效將紅光縮成小光點，抑制擴散範圍，檢距5cm，可減少因被測物顏色不一造成檢知困難。

PK5-F05N flat body 3.5x15x20mm can be installed in small space, plus the focus lens, red light have small spots, suppress the diffusion range, sensing distance 5cm.

其它

## P003 滑軌上極限定位檢知 / Detect positions or rails.

53 / 52頁

Photo / Area Photo /  
Ultrasonic Sensor

Inductive / Capacitive  
Proximity Sensor

Others

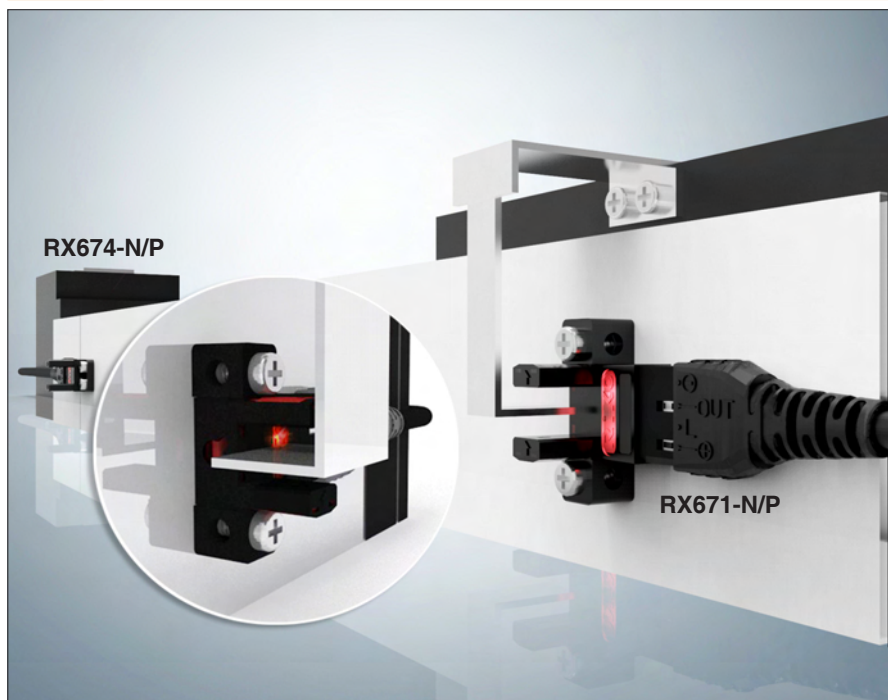

### 型號 / Model

**RX674-N/P / RX671-N/P**

### 檢知條件 / Application

非透光1.5mm厚x6mm長，矩型金屬鐵片。

Metal iron detection, length 6mm thickness 1.5mm.

### 產品特性 / Features

U型溝槽寬幅6mm，防干擾電路設計可減少因環境的油汙，震動造成的誤動作當光電素子被機構上的檔片遮蔽判斷滑軌到達定位點，RX67系列光電素子，有16種安裝固定方式供選用。

U-shaped groove width 6mm, integrated molding Body, can reduce oil pollution and vibration due to the environment to resulting malfunction. It is judged by the flaps on the mechanism that the slide rail reaches the anchor point.

## P004 小型貨架用區域光柵 / To confirm removed parts.

68頁

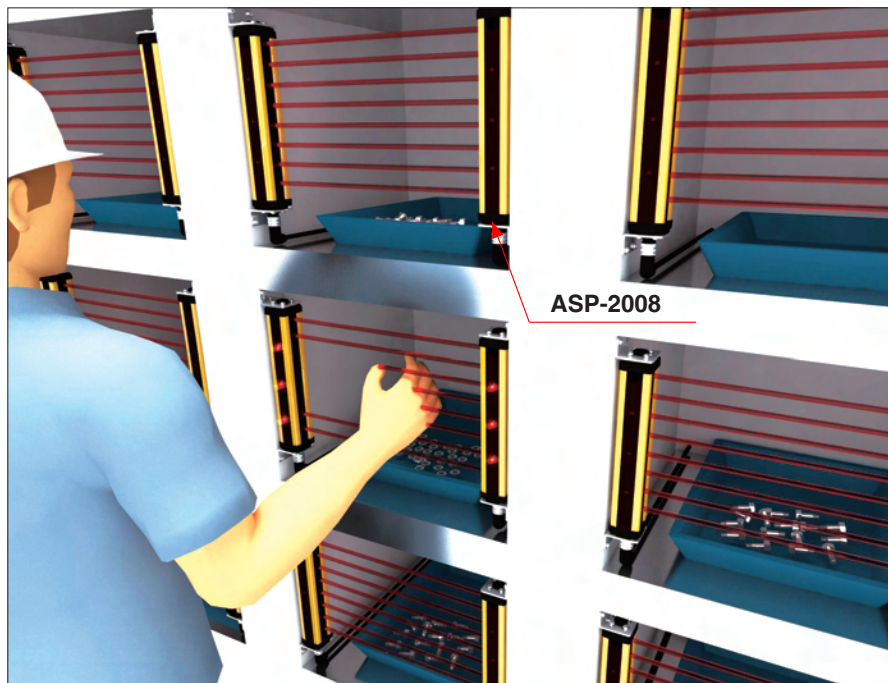

### 型號 / Model

**ASP-2008**

### 檢知條件 / Application

手掌及手臂的偵測或大於直徑30mm以上不透光材質。

Shelf parts removal, the palm and arm are detected or larger than the diameter 30mm or more opaque material.

### 產品特性 / Features

光柵8光軸，間距20mm，保護高度140mm，鋁擠型結構本體，大面積動作指示燈，最小檢測物 >30mm不透明物，運用在小型電子貨架，零件取出管控。

Area Sensor, 8 of Beams, Beam pitch 20mm, Sensing Height 140mm, Durable aluminum extrusion structure, resolution: 30mm opaque object. Applied in Small electronic shelf, parts removal control.

## P005 工件堆疊滿料時檢知 / Detecting full level of materials.

30頁

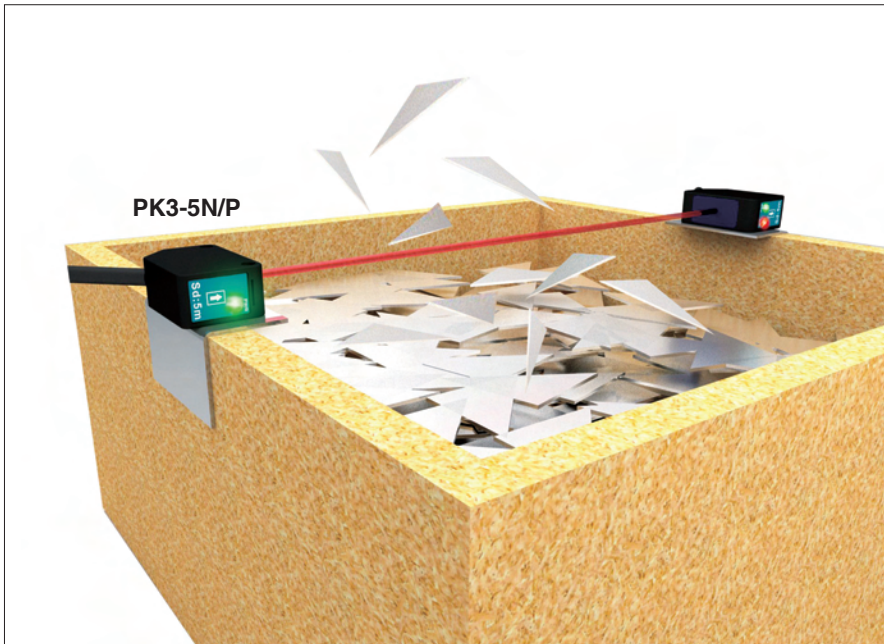

### 型號 / Model

PK3-5N/P

### 檢知條件 / Application

非透明性的材質，能有效遮斷光軸，讓感測器確實驗出。

Full material detection, non-transparent material that effectively blocks light the axis allows the sensor to detect.

### 產品特性 / Features

檢出安裝距離小於5M，設定安裝同一個水平點，當材料持續堆疊到回收區直到遮蔽光電的光軸，即可檢出。

Installation distance is less than 5M, set the security Install the same horizontal point, when the material continues to pile stacked into the recycling area until the light is blocked the axis can be detect.

光電/光柵/超音波感測器

電感式/靜電容近接開關

## P006 洗車機械機構定位 / Detecting the position of cars.

37頁



### 型號 / Model

PTQ18-20N/P

### 檢知條件 / Application

當洗車機械將公車/旅遊巴士往前移動，直到遮蔽光電的光軸。

When the car wash machine take the car move forward until the optical axis of the photo sensor is blocked.

### 產品特性 / Features

防水等級IP66，紅外線對照式光電，檢距20M，可減少因水氣、汗水造成的檢知困擾。

IP66, infrared through beam, with a distance of 20M, can reduce water and gas, the detection caused by sewage is troubled.

其它

## P007 大型輸送設備定位 / Detecting position in conveyer.

20頁

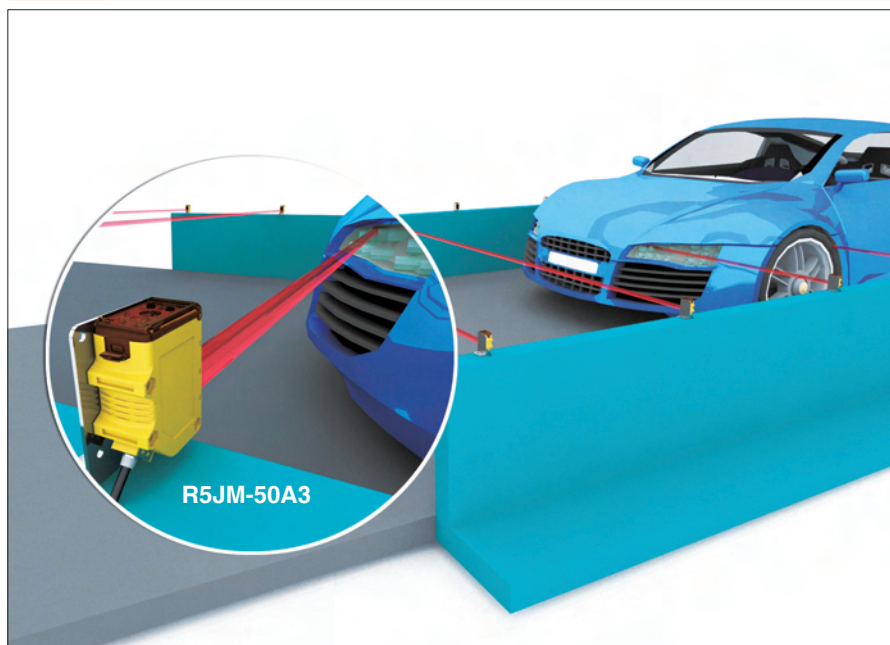

## 型號 / Model

R5JM-50A3

## 檢知條件 / Application

自用车生產工廠，當輸送設備要移載到下一站前，遮蔽光電投光源檢知。  
Conveyor positioning, car production factory, when conveying equipment Before moving to the next station, shading the photo sensor detection.

## 產品特性 / Features

紅外線對照式光電，檢距50M，適用於各式自動化輸送線系統，機構定位。  
Infrared through beam, with a distance of 50M, suitable for all kinds of automated conveyor line systems, institutional positioning.

## P008 高亮光澤表面瓶子 生產數量檢知計數 / Detecting wine bottle.

22頁

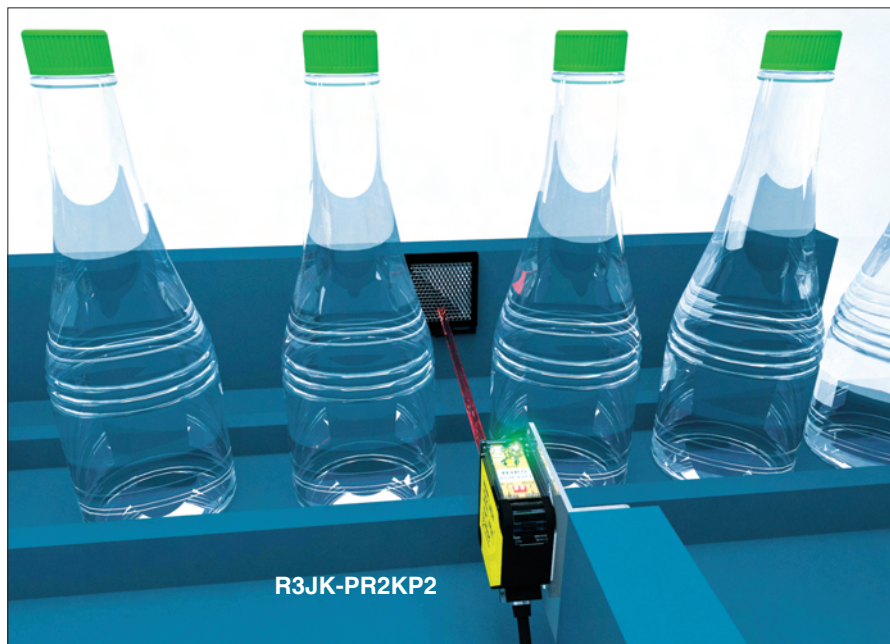

## 型號 / Model

R3JK-PR2KP2

## 檢知條件 / Application

被測物平滑鏡面、高反射率，易造成誤動作。  
Bottle to be measured is smooth, high reflectivity, easy causing false measurements.

## 產品特性 / Features

偏光鏡片反射式光電，非球面光學鏡片設計，檢距2M，採用可見紅光清晰可見，便於操作。  
Retroreflective (Red LED)-Sensing distance 2M, easy to operate.

## P009 PCB電路板到達加工位子檢知 / Detecting location of PCB.

35頁

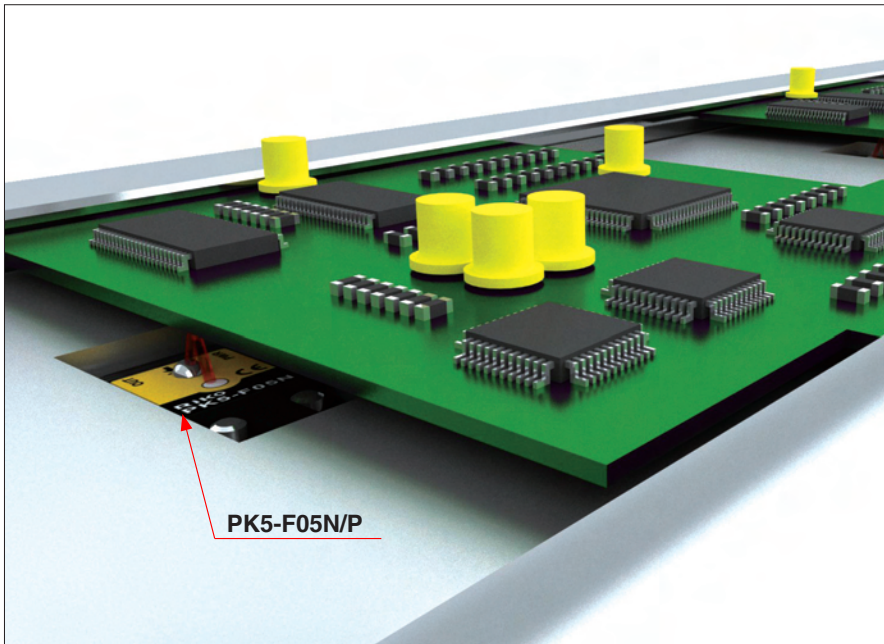

### 型號 / Model

**PK5-F05N/P**

### 檢知條件 / Application

各種顏色PCB板及多種尺寸大小。  
PCB detect, Various color PCB and various sizes.

### 產品特性 / Features

具有光學凸鏡，有效集中可見紅光光源，超薄本體 (3.5mm) 厚度 (不含凸鏡)，便於安裝於狹小空間。

Visible red light spot, ultra-thin body (3.5mm) thickness easy to install in tight spaces.

光電/光柵/超音波感測器

電感式/靜電容近接開關

## P010 旋轉凸輪定位控制 / Rotary cam sensing.

52頁

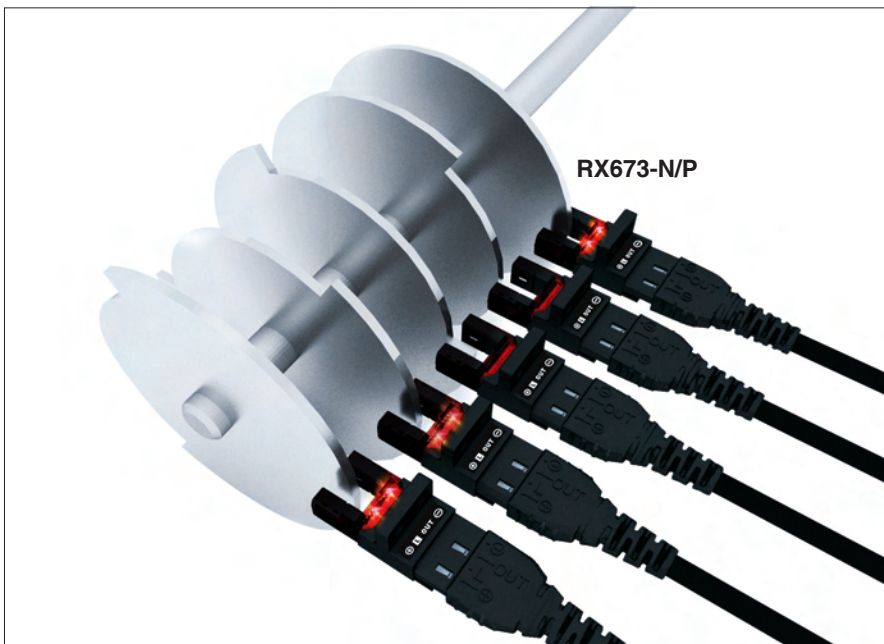

### 型號 / Model

**RX673-N/P**

### 檢知條件 / Application

金屬凸輪，可檢知部位 9mm 深 x2mm厚。

Rotary cam detect, detection site 9mm deep X2mm thick.

### 產品特性 / Features

本體寬幅13.4mm可密集安裝在五個凸輪定位片上，適用於電子、包裝、紡織機械.....等。

Can be installed intensively cam positioning pieces for electric Sub, packaging, textile machinery, etc.

其它

## P011 輸送設備機構定位 / Positioning the moving-part.

48頁

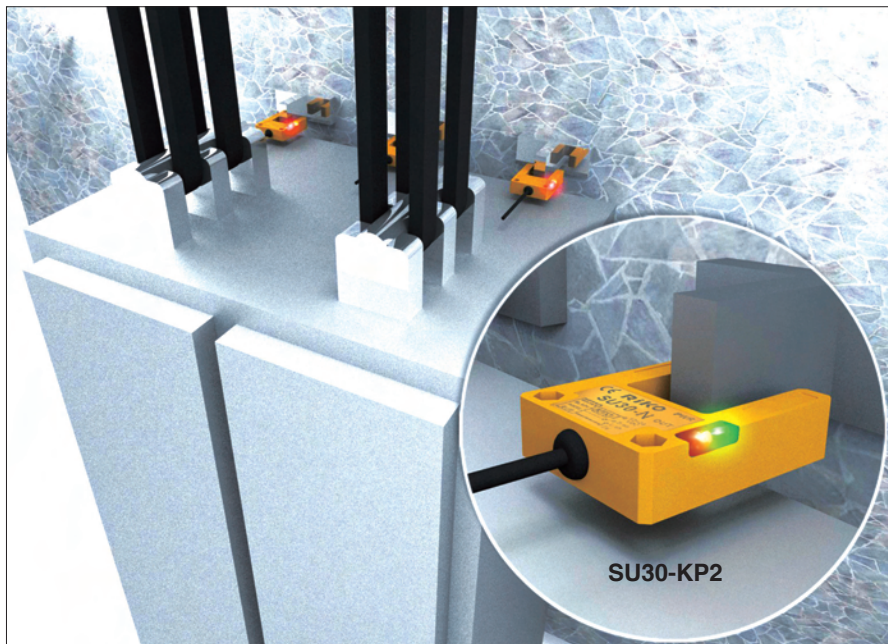

## 型號 / Model

SU30-KP2

## 檢知條件 / Application

不透光工件，10mm寬x30mm長。  
Position detect, Opaque workpiece  
,10mm wide x 30mm long.

## 產品特性 / Features

U型光電，寬幅30mm檢出範圍  
大，齊平式發射/接收視窗，不會卡  
污垢，大型雙色指示燈 (電源綠燈 /  
動作紅燈)。

U-Shape photo sensor,  
sensing distance 30mm.

## P012 油壓機械工作中 有外物入侵檢知 / To protect equipment.

68頁

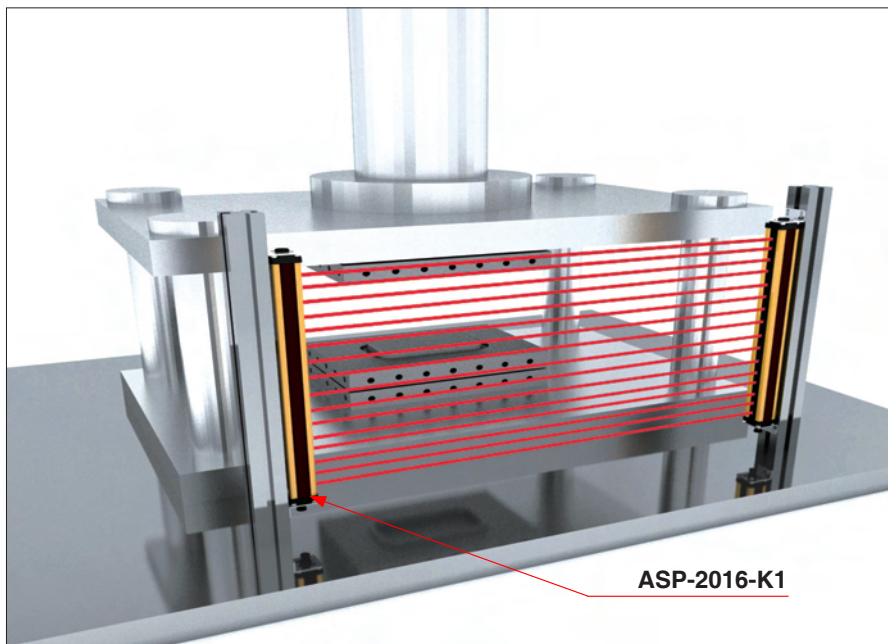

## 型號 / Model

ASP-2016-K1

## 檢知條件 / Application

直徑大於30mm，長30mm非透光  
物體，油壓機械工作區域。

To protect equipment, detect objects  
larger than 30mm in diameter and  
30mm in length.

## 產品特性 / Features

鋁擠外殼區域光閘(16光軸)，300mm  
檢知高度，光軸間距20mm，密集  
的光軸束有效檢知，手掌的防護，大面  
積動作燈清晰可見。

Area Sensor, 16 of Beams, Beam  
pitch 20mm, Sensing Height 300mm,  
Durable aluminum extrusion  
structure, resolution: 30mm object.

**P013** 覆捲機台運動控制 / Detecting a reel.

68頁

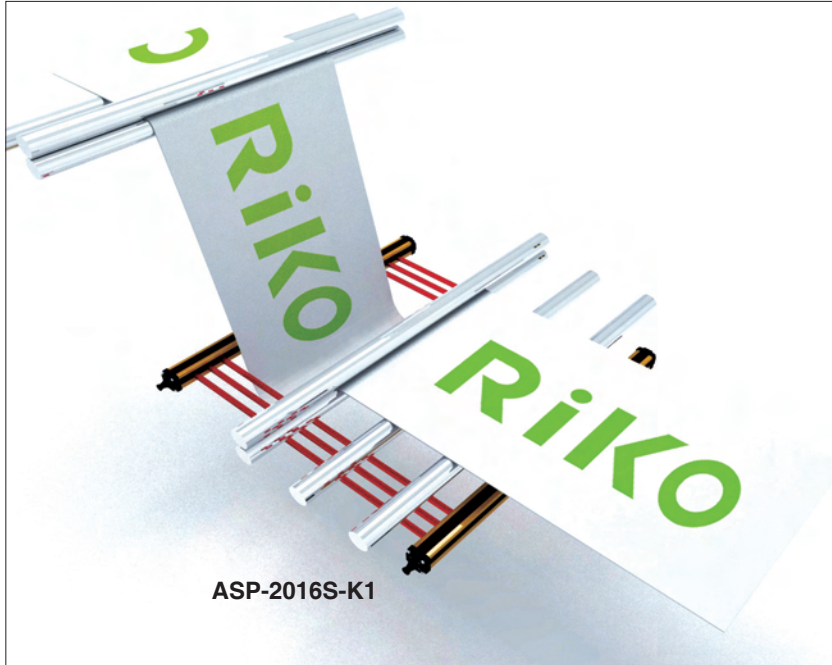

**型號 / Model**

ASP-2016S-K1

**檢知條件 / Application**

直徑大於60mm以上的不透光材質。  
Wrapping materials detection.

**產品特性 / Features**

440mm檢出範圍，鋁擠外殼設計，大面積動作燈清晰可見，當覆捲材料於收/送料過程中，覆捲材料遮蔽到光柵的光源即檢出送出信號到PLC/變頻器，來做穩定的速度及張力控制。

Area Sensor, 16 of Beams, Beam pitch 20mm, Sensing Height 300mm, Durable aluminum extrusion structure, when the wrapping material is covered during the receiving/feeding process the light source is shaded and detected. Send a signal to the PLC to do stable speed and tension control.

光電/光柵/超音波感測器

電感式/靜電容近接開關

其它

**P014**

32/36頁

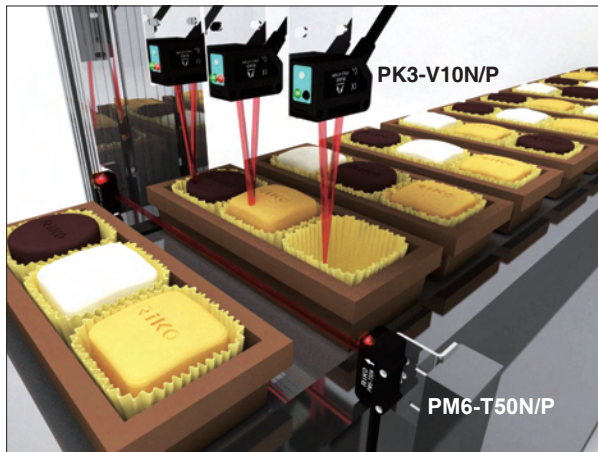

巧克力通過及有無  
Detecting chocolate presence and passing.

**P015**

35頁



檢測有無瓶蓋  
Detecting presence of cap.

**P016**

76頁

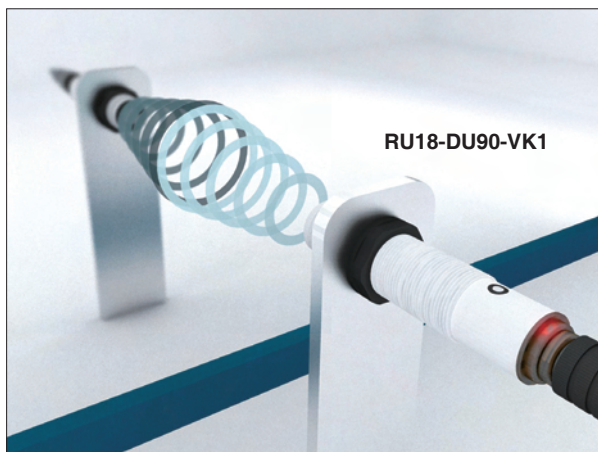

鏡面物體檢測  
To detect the mirror surface objects.

**P017**

76頁

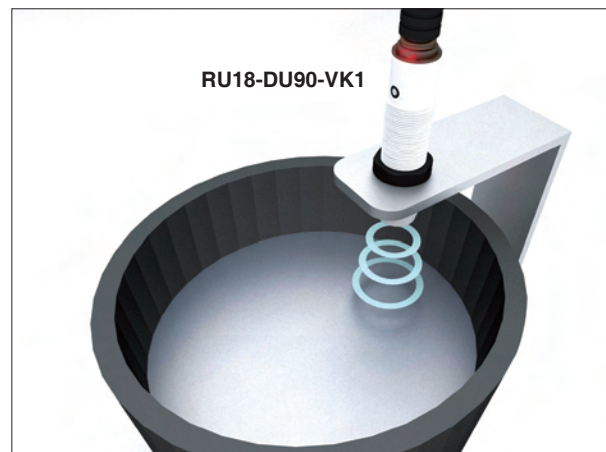

檢測桶槽料位  
To detect the level of tank.

P018

20頁

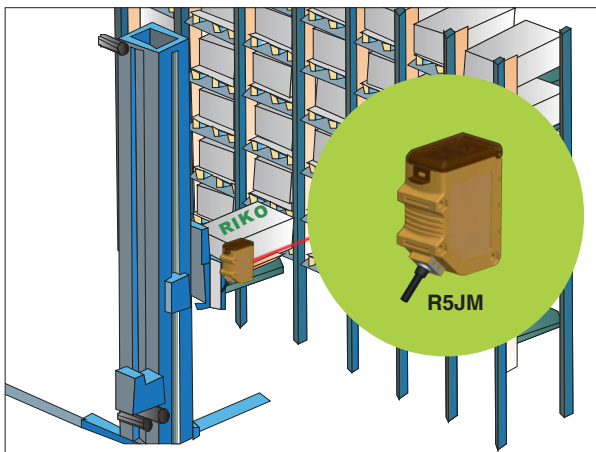

檢測物品是否完全入架

Detecting if the total boxes on the stacks.

P019

20頁

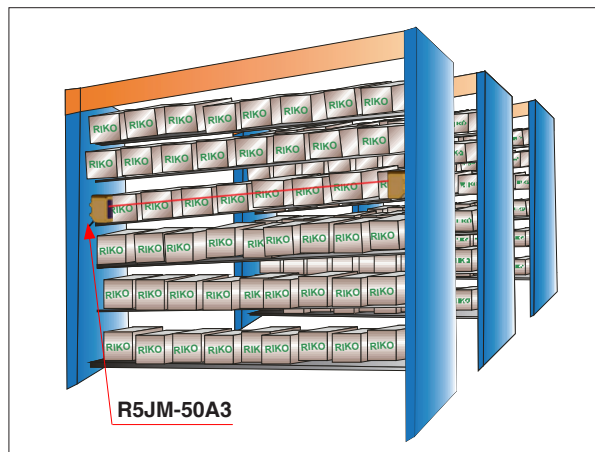

自動倉儲檢測

Detecting automatic storage & retrieval system.

P020

21頁



車庫車輛進出確認

Detecting if the car drive out of garage.

P021

20頁

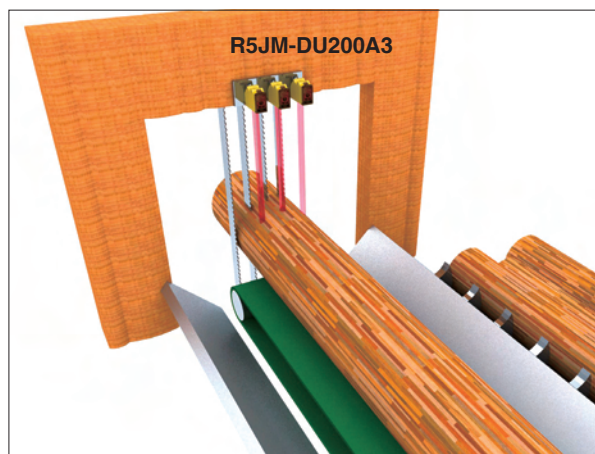

伐木檢測

Detecting lumbering.

P022

37頁

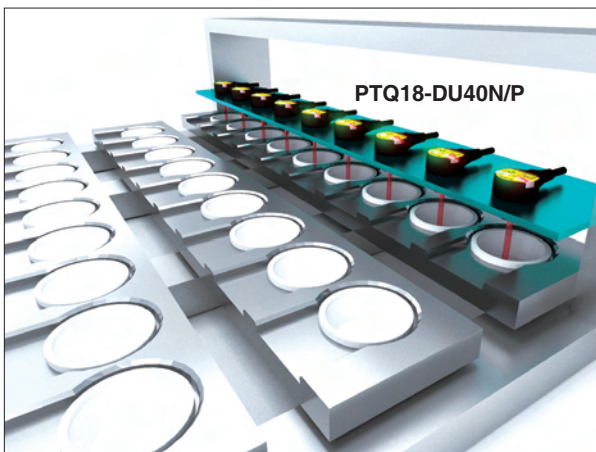

檢測有無盒子

Detecting presence of box.

P023

22頁

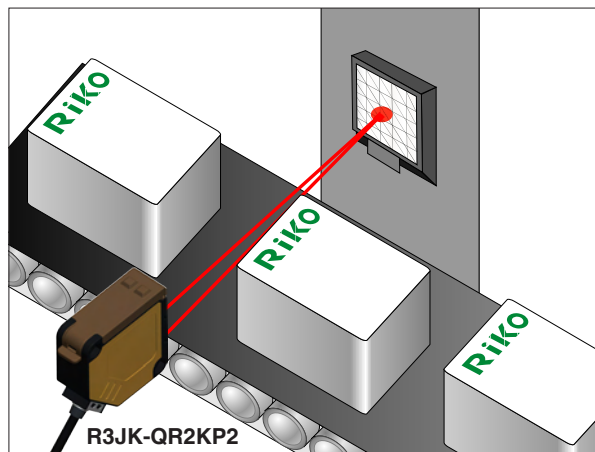

檢測紙盒通過

Detecting box passing.

Photo / Area Photo / Ultrasonic Sensor

Inductive / Capacitive Proximity Sensor

Others

P024

22頁

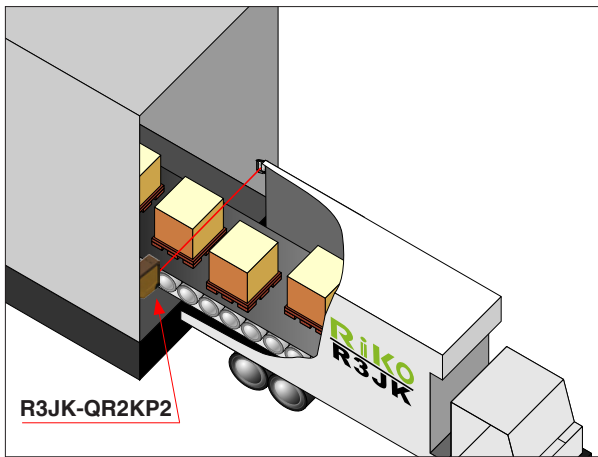

檢測貨物進出  
Detecting cargo delivery in / out.

P025

37頁



滿料檢知  
Detecting full level of materials.

P026

21頁

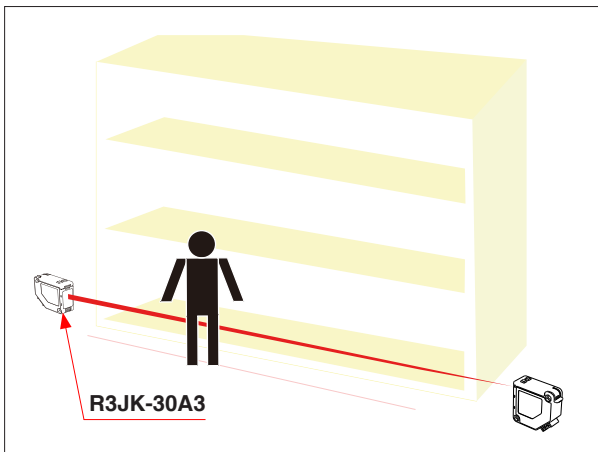

人員進入檢測  
Detecting people entrance.

P027

38頁

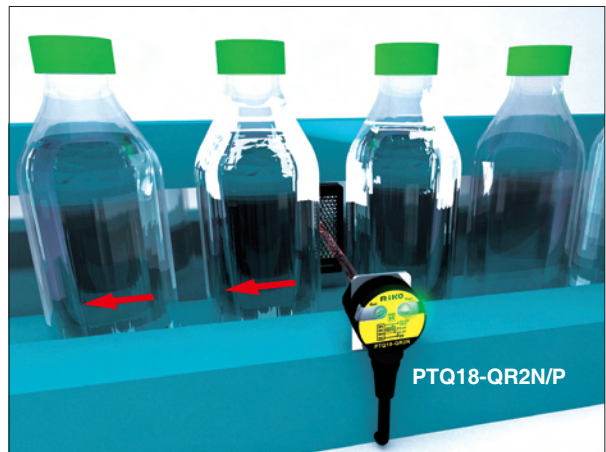

檢測高速行進的瓶子  
Counting clear bottles moving on a high-speed conveyor.

P028

37頁

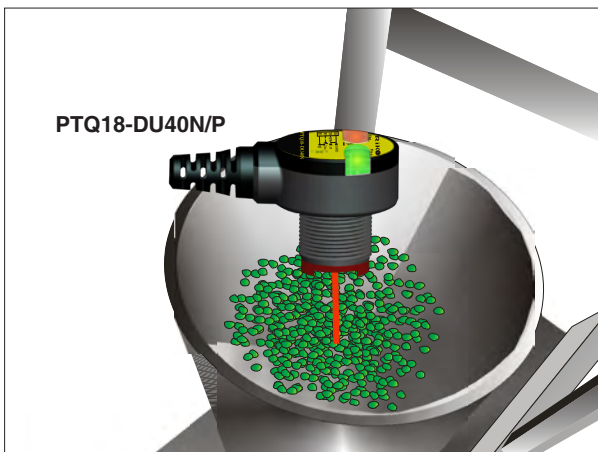

料位控制  
Controlling the position of object.

P029

32頁

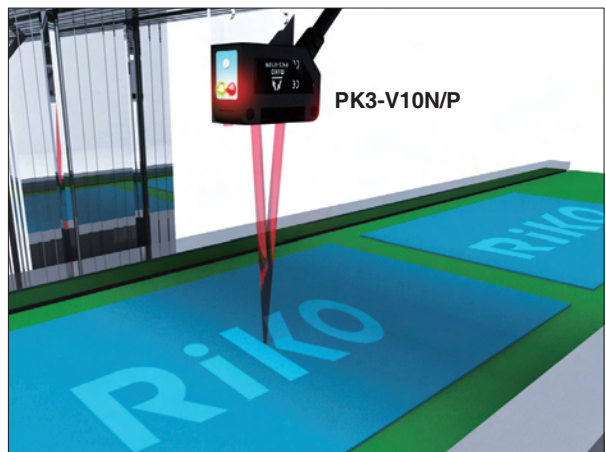

檢測桶槽料位  
Detecting the planks.

光電/光柵/超音波感測器

電感式/靜電容近接開關

其它

P030

31頁

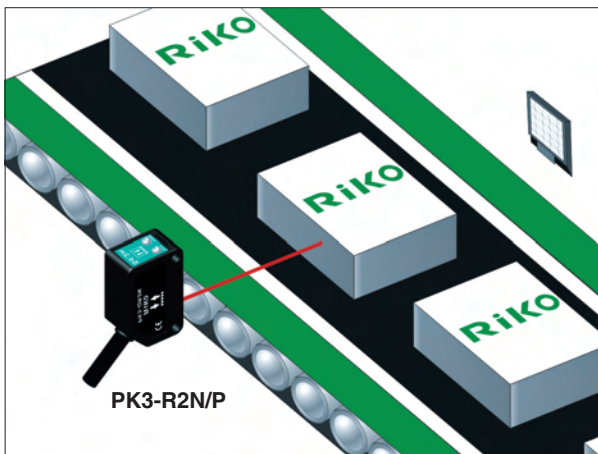

檢測產品通過  
Detecting the passing of products.

P031

24頁

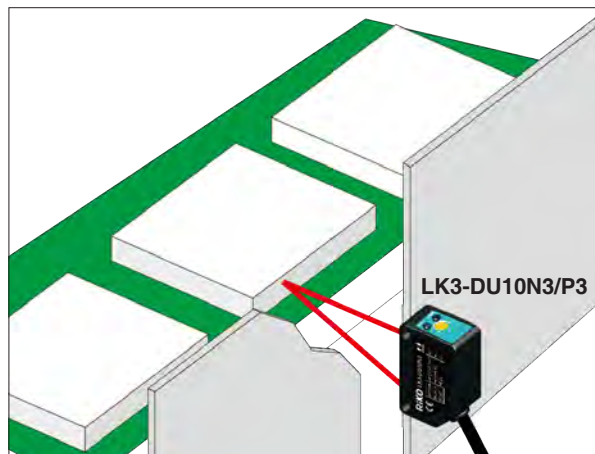

零件檢測  
Detecting parts.

P032

32頁

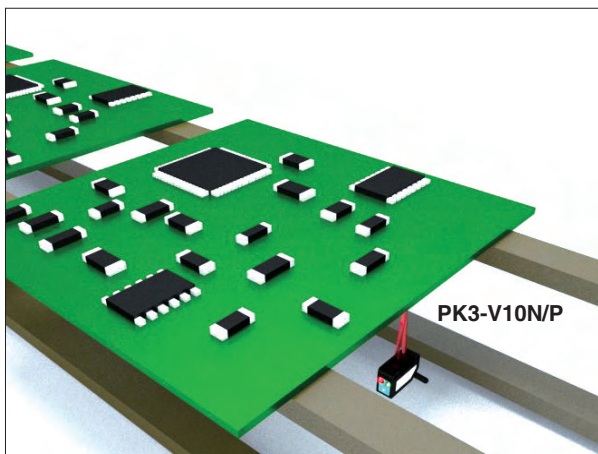

檢測PCB定位  
Detecting location of PCB.

P033

32頁

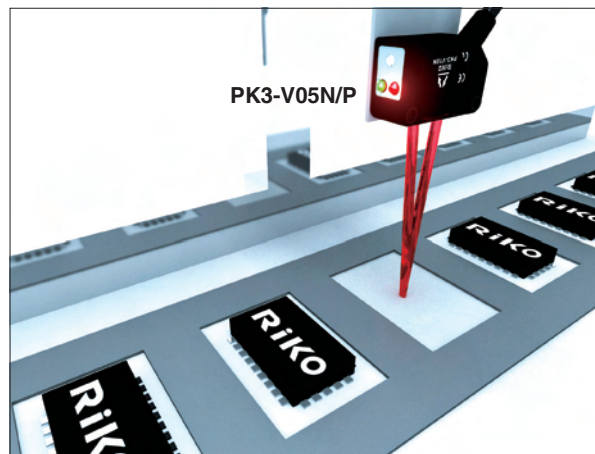

檢測有無IC  
Detecting if the IC is existed or not.

P034

35頁

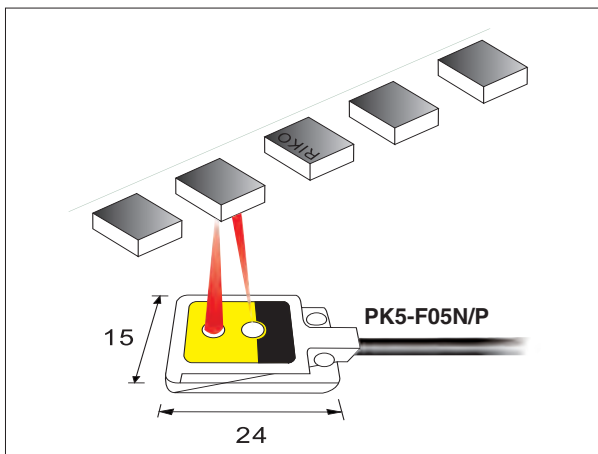

檢測PCB定位  
Detecting presence of object.

P035

35頁

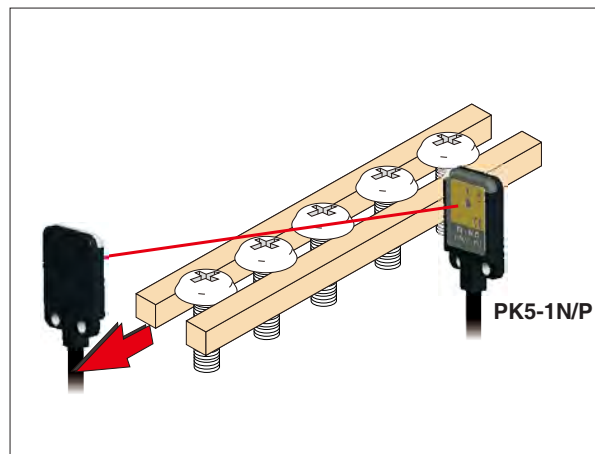

檢測輸送帶上的螺絲  
To detect the screws in conveyer.

Photo / Area Photo /  
Ultrasonic Sensor

Inductive / Capacitive  
Proximity Sensor

Others

P036

35頁

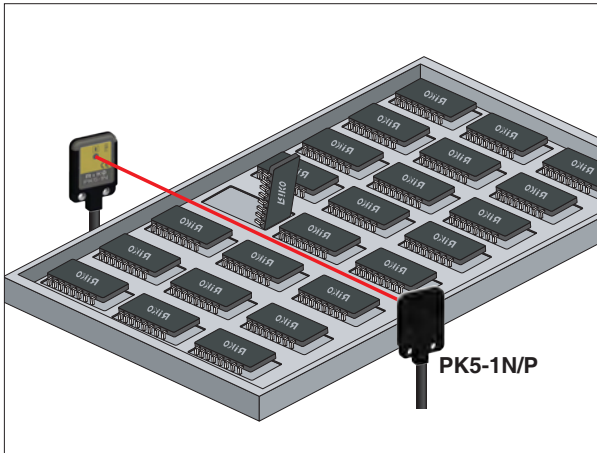

**檢測IC翻開**  
Detecting the unseated IC.

P037

35頁

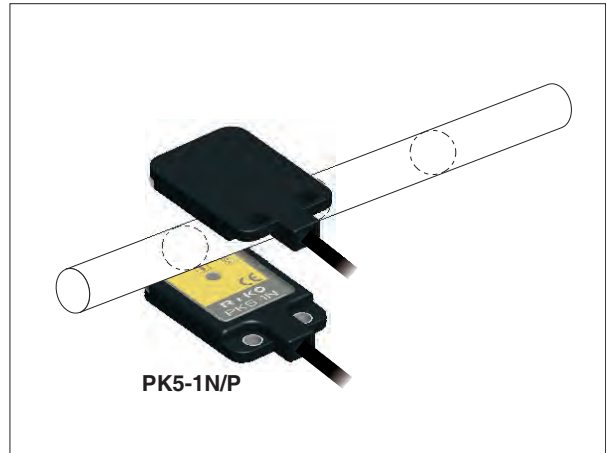

**檢測鋼珠通過**  
To detect the steel balls passing inside the glass tube.

P038

24頁

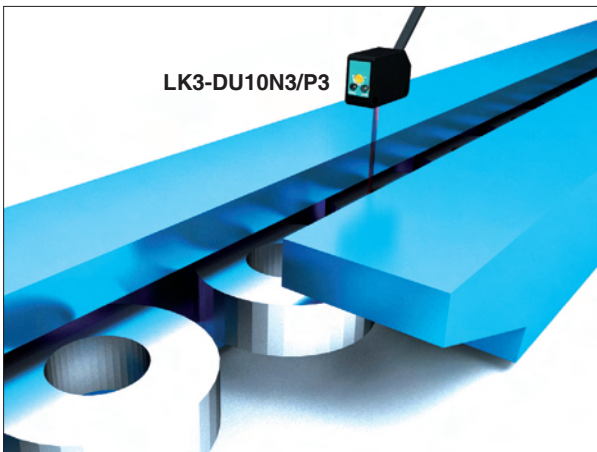

**檢測金屬沖壓件**  
Detecting metal stamping parts.

P039

36頁

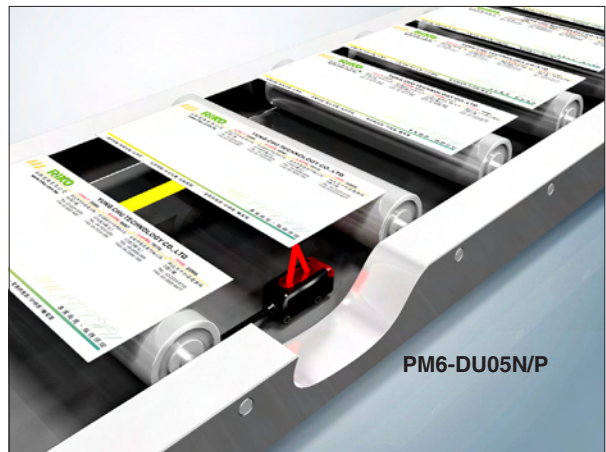

**檢測信封**  
Detecting the envelope.

P040

36頁

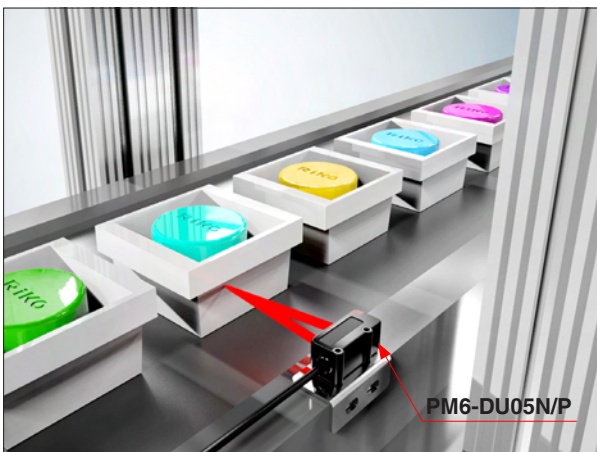

**檢測產品通過**  
Detecting the passing of products.

P041

36頁



**檢測有無蓋子**  
Detecting the lid on the product is existed or not.

光電/光柵/超音波感測器

電感式/靜電容近接開關

其它

P042

36頁

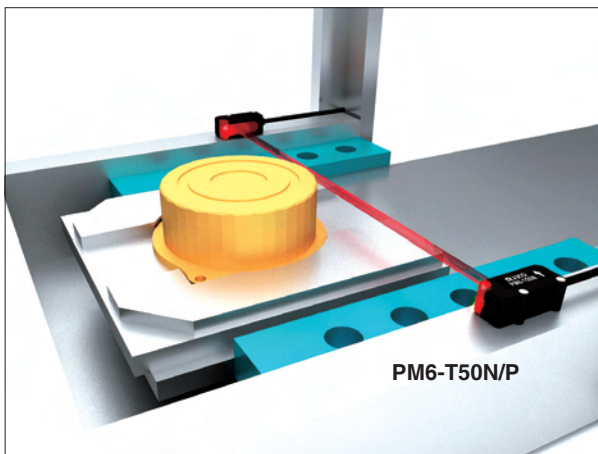

檢測產品通過  
Detecting presence of object.

P043

46頁

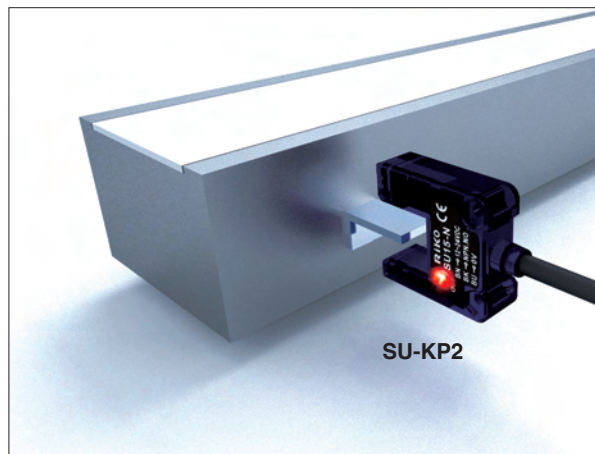

位置檢知  
Machine positioning.

P044

44頁

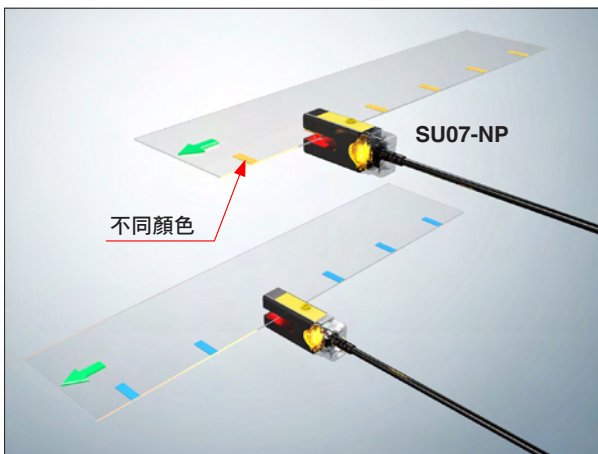

使用於封口機  
Sealing machine.

P045

44頁

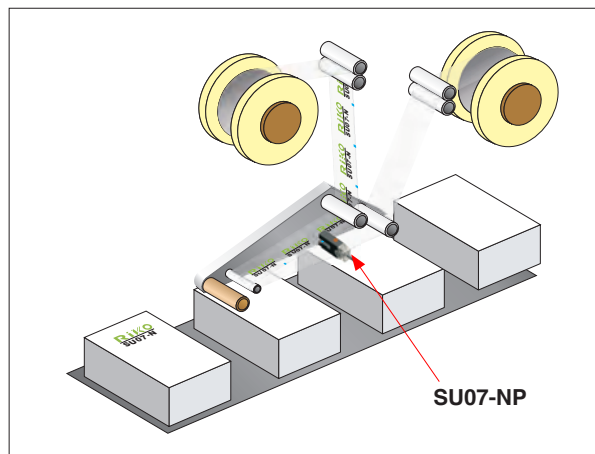

檢測印刷記號點  
Detecting printing TAB marks.

P046

44頁

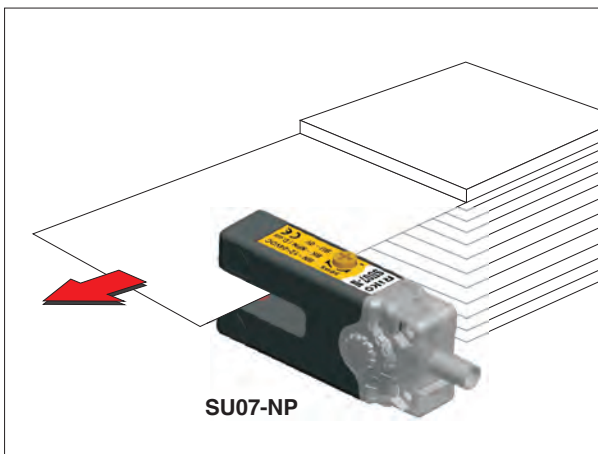

紙板檢測  
Detecting the pasteboard.

P047

51頁

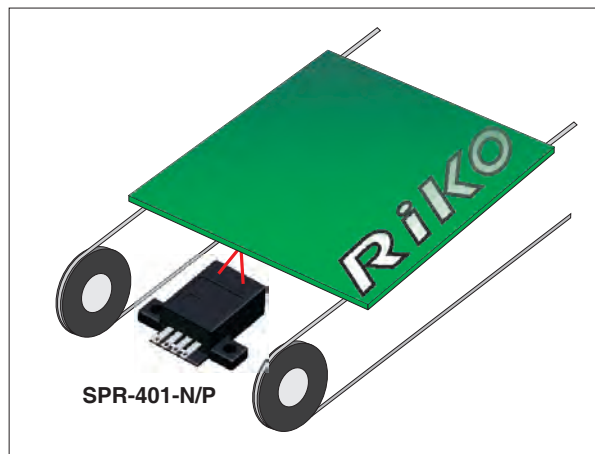

檢測PCB  
Detecting PCB.

Photo / Area Photo /  
Ultrasonic Sensor

Inductive / Capacitive  
Proximity Sensor

Others

P048

51頁

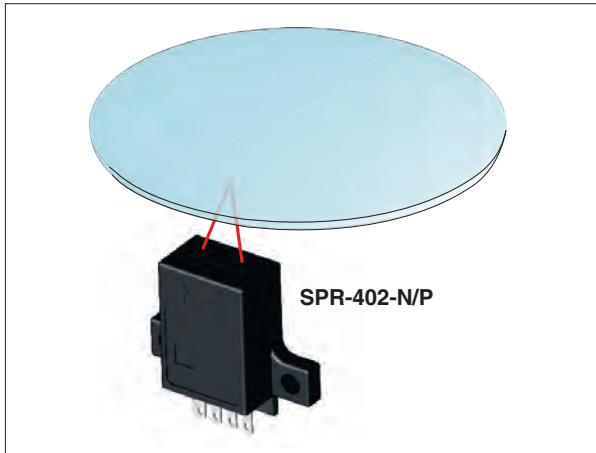

檢測圓盤  
To detect the disc.

P049

56頁

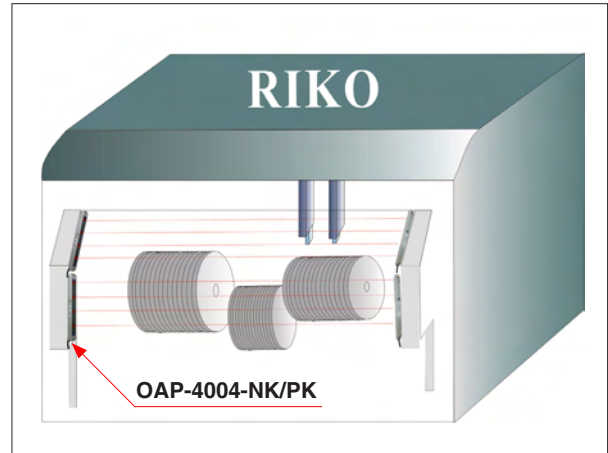

保護不受外物入侵  
To avoid the intrusion of objects from outside of the machine.

P050

56頁

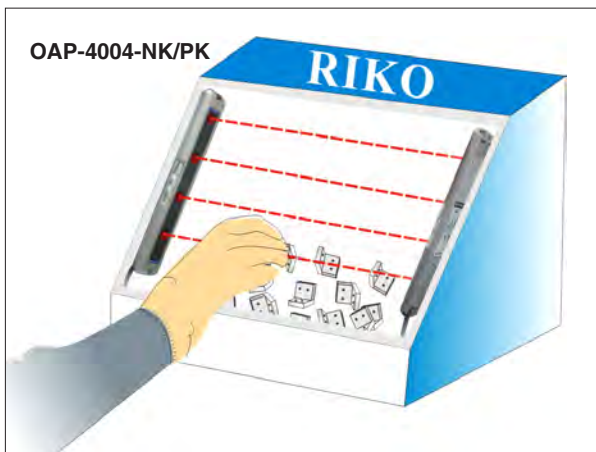

手臂防護  
To protect arm.

P051

68頁

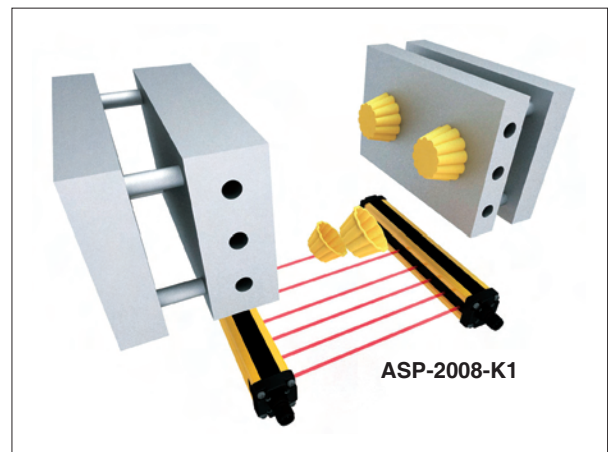

不規則物掉落檢知  
Detecting objects with irregular shapes.

P052

76頁



透明物體檢測  
For transparent object detection.

P053

35頁

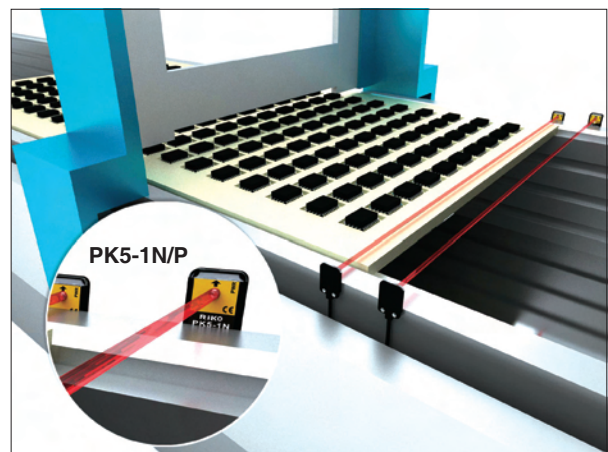

檢測IC是否翻開  
Detecting the unseated IC.

光電/光柵/超音波感測器

電感式/靜電容近接開關

其它

## R5JM系列

**A3 輸出或接收**  
A3 Output or Receiver

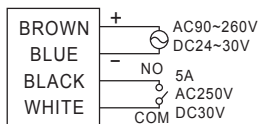

**A3 發射**  
A3 Emitter

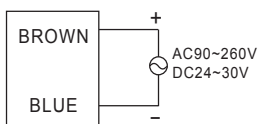

## R3JK系列

**A3 輸出或接收 /**  
A3 Output or Receiver

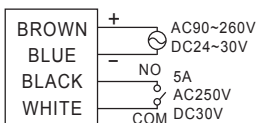

**KP2 輸出或接收 /**  
KP2 Output or Receiver

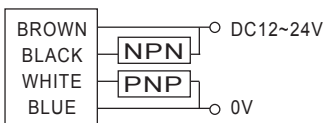

**KP2K 輸出或接收 /**  
KP2K Output or Receiver

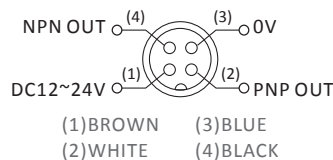

**A3 發射 /**  
A3 Emitter

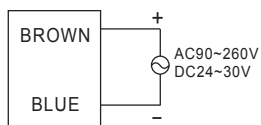

**KP2 發射 /**  
KP2 Emitter

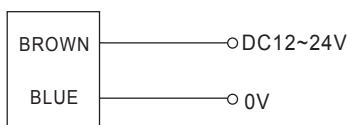

**KP2K 發射 /**  
KP2K Emitter

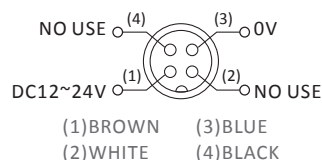

## LK 系列

**擴散反射式 / Diffuse reflection**  
N3 輸出 / N3 Output

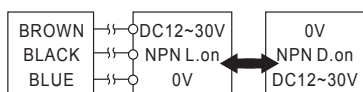

**擴散反射式 / Diffuse reflection**  
P3 輸出 / P3 Output

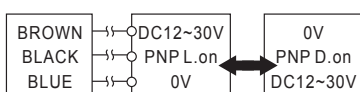

**擴散反射式 / Diffuse reflection**  
B3 輸出 / B3 Output

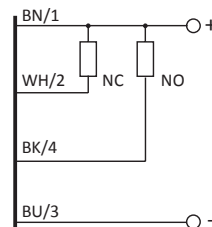

## PK3系列

**鏡片反射式 & 對照式 & 擴散反射式 / Retroreflective & Through beam & Diffuse reflection**

**NPN 輸出或接收 / NPN Output or Receiver**

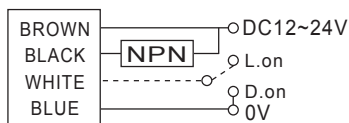

**PNP 輸出或接收 / PNP Output or Receiver**

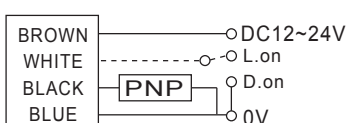

**B 輸出或接收 / B Output or Receiver**

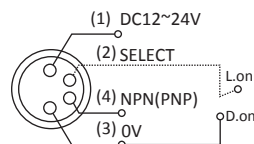

**發射 /**  
Emitter

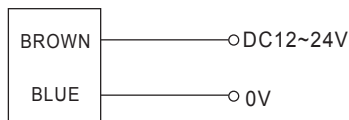

**B 發射 /**  
B Emitter

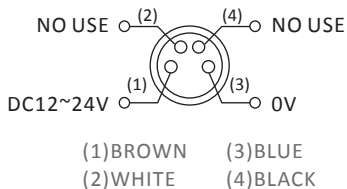

(1) BROWN (3) BLUE  
(2) WHITE (4) BLACK

(1) BROWN (3) BLUE  
(2) WHITE (4) BLACK

## PK5&PM6系列

NPN 輸出或接收 /  
NPN Output or Receiver

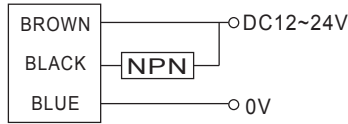

PNP 輸出或接收 /  
PNP Output or Receiver

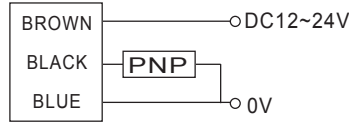

發射 /  
Emitter

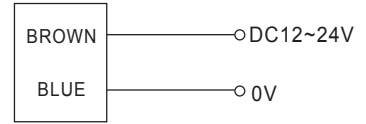

## PTQ18系列

擴散反射式 / Diffuse reflection  
NPN 輸出 / NPN Output

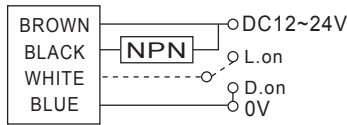

擴散反射式 / Diffuse reflection  
PNP 輸出 / PNP Output

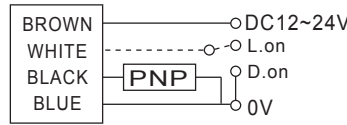

擴散反射式 / Diffuse reflection  
K1 輸出 / K1 Output

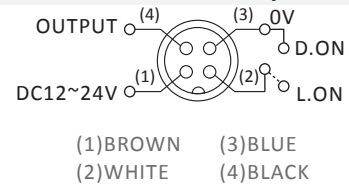

鏡片反射&對照式/Retroreflective&Through beam  
NPN 輸出或接收 / NPN Output or Receiver

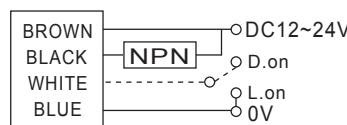

鏡片反射&對照式/Retroreflective&Through beam  
PNP 輸出或接收 / PNP Output or Receiver

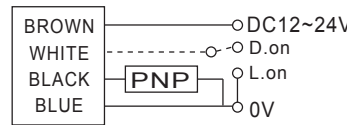

鏡片反射&對照式/Retroreflective&Through beam  
K1 輸出或接收 / K1 Output or Receiver

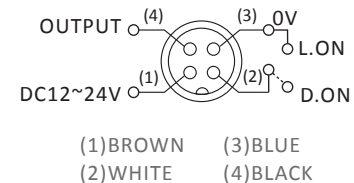

擴散反射式 / Diffuse reflection  
NP 輸出 / NP Output

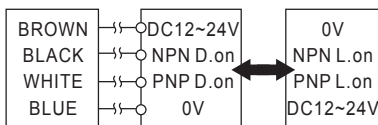

擴散反射式 / Diffuse reflection  
NPK1 輸出 / NPK1 Output

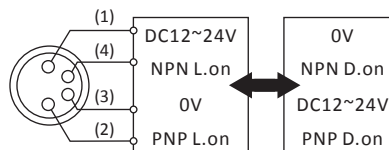

發射 /  
Emitter

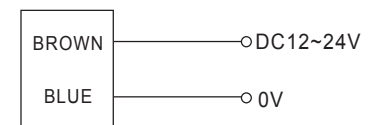

鏡片反射&對照式/Retroreflective&Through beam  
NP 輸出或接收 / NP Output or Receiver

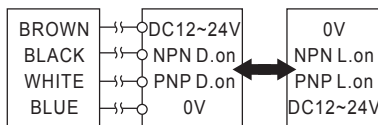

鏡片反射&對照式/Retroreflective&Through beam  
NPK1 輸出或接收 / NPK1 Output or Receiver

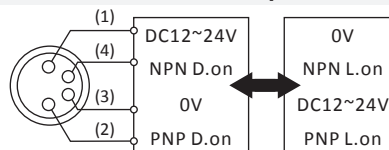

K1 發射 /  
K1 Emitter

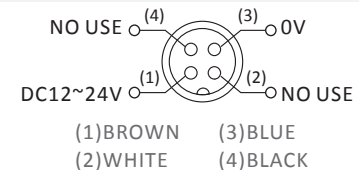

## RMF&MMF系列

擴散反射式 / Diffuse reflection  
NPN 輸出 / NPN Output

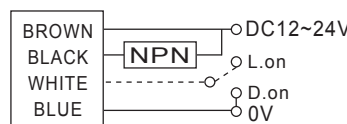

擴散反射式 / Diffuse reflection  
PNP 輸出 / PNP Output

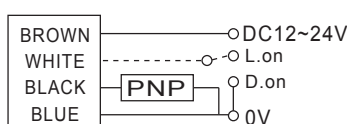

擴散反射式 / Diffuse reflection  
K/K1 輸出 / K/K1 Output

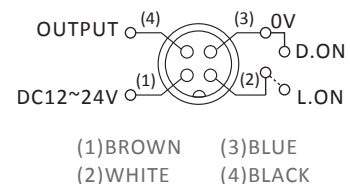

RMF-DU30KP2

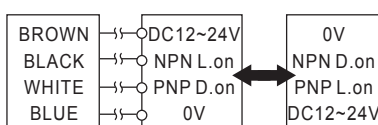

RMF-10KP2 Receiver

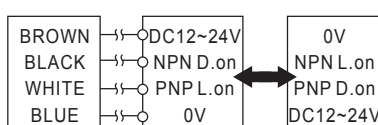

光電/光柵/超音波感測器

電感式/靜電容近接開關

其它

## RMF&MMF系列

鏡片反射&對照式/Retroreflective&Through beam  
NPN 輸出或接收 / NPN Output or Receiver

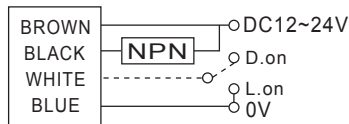

發射 /  
Emitter

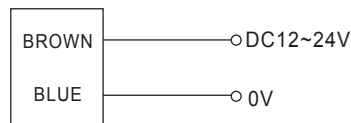

鏡片反射&對照式/Retroreflective&Through beam  
PNP 輸出或接收 / PNP Output or Receiver

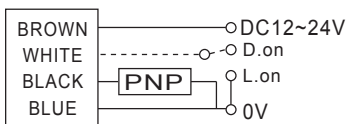

K1 發射 /  
K1 Emitter

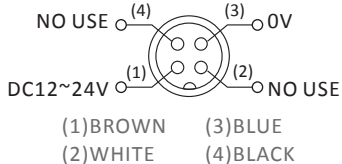

鏡片反射&對照式/Retroreflective&Through beam  
K/K1 輸出或接收 / K/K1 Output or Receiver

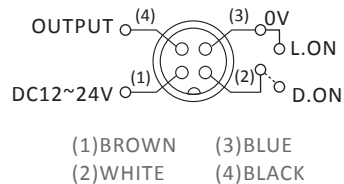

(1)BROWN (3)BLUE  
(2)WHITE (4)BLACK

## SU / SU07 / SU18 系列

NPN 輸出 /  
NPN Output

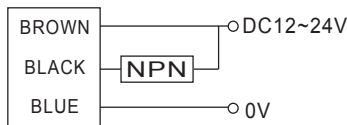

PNP 輸出 /  
PNP Output

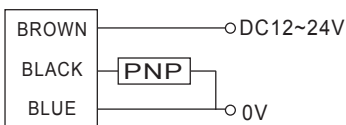

NP 輸出 /  
NP Output

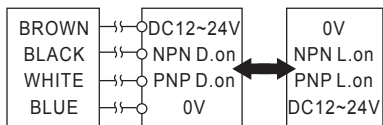

NPB1 輸出 /  
NPB1 Output

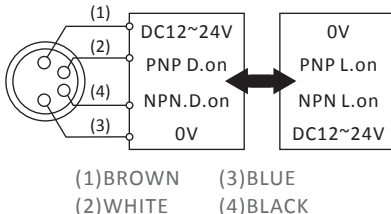

(1)BROWN (3)BLUE  
(2)WHITE (4)BLACK

NB1 輸出 /  
NB1 Output

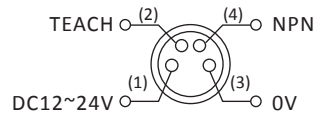

(1)BROWN (3)BLUE  
(2)WHITE (4)BLACK

N3 輸出 /  
N3 Output

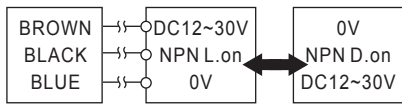

P3 輸出 /  
P3 Output

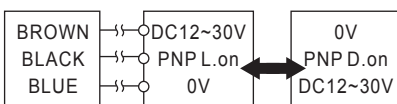

KP2 輸出 /  
KP2 Output

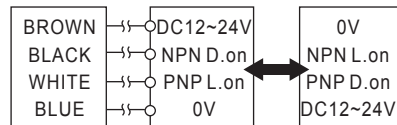

## SU30系列

KP2 輸出 /  
KP2 Output

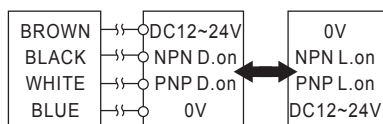

NP2K1 輸出 /  
NP2K1 Output

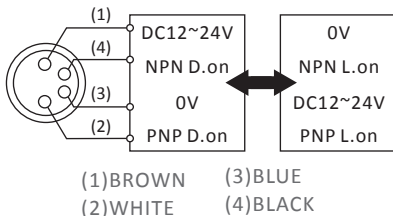

(1)BROWN (3)BLUE  
(2)WHITE (4)BLACK

2N/2PK1 輸出 /  
2N/2PK1 Output

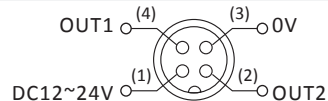

(1)BROWN (3)BLUE  
(2)WHITE (4)BLACK

2NPN 輸出 /  
2NPN Output

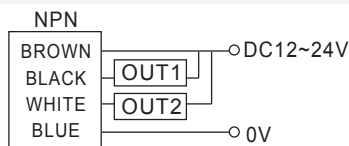

2PNP 輸出 /  
2PNP Output

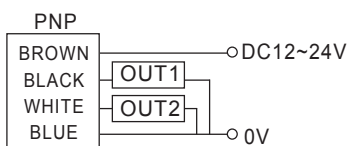

# 光電感測器

# OPTIONS

## 訂貨索引 Order Information

R5JM - DU200 A3

超長距離方形光電開關 Ultra-long sensing range Photo Sensor	<b>R5JM</b>
長距離檢測方形光電開關 Long sensing range Photo Sensor	<b>R3JK</b>
雷射光電開關 Laser Photo Sensor	<b>LK</b>
雷射光電感測器 Laser Photoelectric Sensors	<b>LRS</b>
小方形光電開關 Rectangular Photo Sensor	<b>PK3</b>
背景抑制小方形光電開關 Rectangular photoelectric sensor(background suppression)	<b>PKG3</b>
微小薄形光電開關 Micro-sized Flat Photo Sensor	<b>PK5</b>
微小方形光電開關 Micro-sized Square Photo Sensor	<b>PM6</b>
高防水性 T形光電開關 Superior Waterproof T-style Photo Sensor	<b>PTQ18</b>
光電開關塑膠外殼 M18 Photo switch Plastic housing	<b>RMF</b>
光電開關金屬管外殼 M18 Photo switch Met00al housing	<b>MMF</b>
U型光電 U-shape Photo Sensor	<b>SU</b>
光電素子 Micro Photo Sensor	<b>SPR/ RX</b>
光柵 General Purpose Compact Area Sensor	<b>OAP/ ASP</b>
超音波感測器 Ultrasonic Sensor	<b>RU</b>

限定距離反射式-檢測距離 5cm Convergent reflective type-Sensing distance 5cm	<b>V05</b>
限定距離反射式-檢測距離 10cm Convergent reflective type-Sensing distance 10cm	<b>V10</b>
擴散反射式(紅光小光點)-檢測距離 5cm Diffuse reflective(small spot from LED Red light) Sensing distance 5cm	<b>F05</b>
擴散反射式-檢測距離 5cm Diffuse reflective-Sensing distance 5cm	<b>DU05</b>
擴散反射式-檢測距離 10cm Diffuse reflective-Sensing distance 10cm	<b>DU10</b>
擴散反射式-檢測距離 40cm Diffuse reflective-Sensing distance 40cm	<b>DU40</b>
擴散反射式-檢測距離 50cm Diffuse reflective-Sensing distance 50cm	<b>DU50</b>
擴散反射式-檢測距離 1M Diffuse reflective-Sensing distance 1M	<b>DU100</b>
擴散反射式-檢測距離 2M Diffuse reflective-Sensing distance 2M	<b>DU200</b>

對照式-檢測距離 50cm Through beam-Sensing distance 50cm	<b>T50</b>
對照式-檢測距離 1M Through beam-Sensing distance 1M	<b>1</b>
對照式-檢測距離 2M Through beam-Sensing distance 2M	<b>2</b>
對照式-檢測距離 5M Through beam-Sensing distance 5M	<b>5</b>
對照式-檢測距離 10M Through beam-Sensing distance 10M	<b>10</b>
對照式-檢測距離 20M Through beam-Sensing distance 20M	<b>20</b>
對照式-檢測距離 30M Through beam-Sensing distance 30M	<b>30</b>
對照式-檢測距離 50M Through beam-Sensing distance 50M	<b>50</b>

M12接頭15cm電線式 M12 Pigtailed type	<b>K</b>
M12接頭式 M12 plug-in connector type	<b>K1</b>
M8接頭15cm電線式 (4pin) M8 Pigtailed type (4pin)	<b>B</b>
M8接頭15cm電線式 (3pin) M8 Pigtailed type (3pin)	<b>B1</b>
出線式 2M Pre-wired 2M model	
Output NPN N.O.	<b>N</b>
Output PNP N.O.	<b>P</b>
NPN L.on/D.on& PNP L.on/D.on NPN & PNP SYNC. OUT	<b>NP</b>
NPN L.on/D.on& PNP D.on/L.on	<b>KP2</b>
Relay output AC90~260V DC24~30V	<b>A3</b>

鏡片反射式(紅光)-檢測距離 2M Retroreflective(Red LED)-Sensing distance 2M	<b>QM1</b>
鏡片反射式(紅光)-檢測距離 2M Retroreflective(Red LED)-Sensing distance 2M	<b>QR2</b>
偏光鏡片反射式-檢測距離 1M Polarized Retroreflective-Sensing distance 1M	<b>PR1</b>
偏光鏡片反射式-檢測距離 2M Polarizing Retroreflective-Sensing distance 2M	<b>PR2</b>
鏡片反射式-檢測距離 2M Retroreflective-Sensing distance 2M	<b>R2</b>
鏡片反射式-檢測距離 5M Retroreflective-Sensing distance 5M	<b>R5</b>

## Characteristic / 特點 :

- Special protective hood against waterdrop and dust.  
/ 專用防塵蓋設計，可防潑水及灰塵。
- Its special design enhances more durable and rigid.  
/ 特別的機構設計，更加堅固耐用。
- Through beam sensing distance 50M.  
/ 長距對照式，檢距50M。
- Timer function : On-delay / Off-delay.  
/ 有On-delay與Off-delay計時器功能。
- Single output available by request.  
/ 單輸出可另行訂購。



R5JM

光電—光柵—超音波感測器

R5JM  
R3JK  
LK  
LRS  
PK3  
PKG3  
PK5  
PM6

PTQ18  
RMF  
MMF

SU07  
SU  
SU18  
SU30

SPR  
RX

OAP  
ASP

RU18

Model / 型號	R5JM-DU200A3	R5JM-50A3
Sensing type / 檢出方式	Diffuse reflection / 擴散反射式	Through beam / 對照式
Sensing distance / 檢出距離	200cm, White paper 30 x 30 cm	50m
Emitting light / 發光源	Infrared / 紅外線LED 850nm	
Operating voltage / 工作電壓	AC90 ~ 260V DC24~30V	
Current Consumption / 消耗電流	40 mA	
Load current / 負載電流	Relay / 繼電器 : DC30V 5A/ AC250V 5A	
Output type / 輸出模式	Relay out / 繼電器輸出 : Com./NO.	
Response time / 反應頻率	30 Hz	
Insulation resistance / 隔離阻抗	20M Ω min (DC500V)	
Voltage withstandability / 絕緣耐壓	AC1000V 60Hz for 60 Sec.	
Operating temperature / 工作溫度	-25°C ~ + 60°C (不可結霜, 結冰)	
Ambient humidity / 工作溼度	35% ~ 85% RH	
Protection degree / 防水等級	IP65	
Material / 外觀材質	ABS	
Wiring method / 出線方式	Ø5.2 x 2 M / 4-wires	(Receiver) Ø5.2 x 2 M / 4-wires (Emitter) Ø5.2 x 2 M / 2-wires
Weight / 重量	123.5g	247g

## Dimensions / 尺寸圖 (mm)

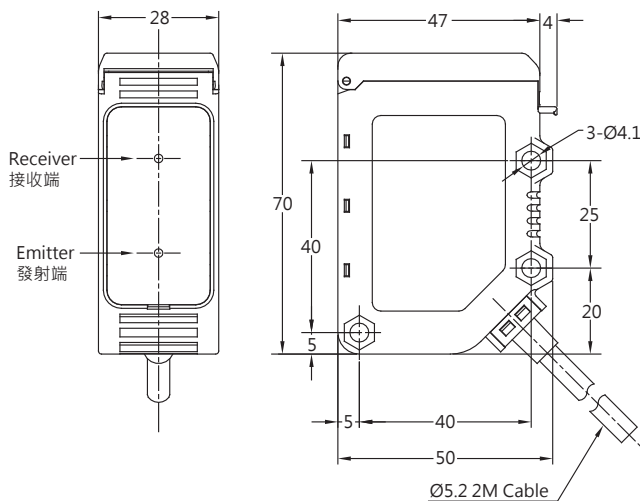

## Functions manual of panels / 面板功能說明

### A3 Output or Receiver

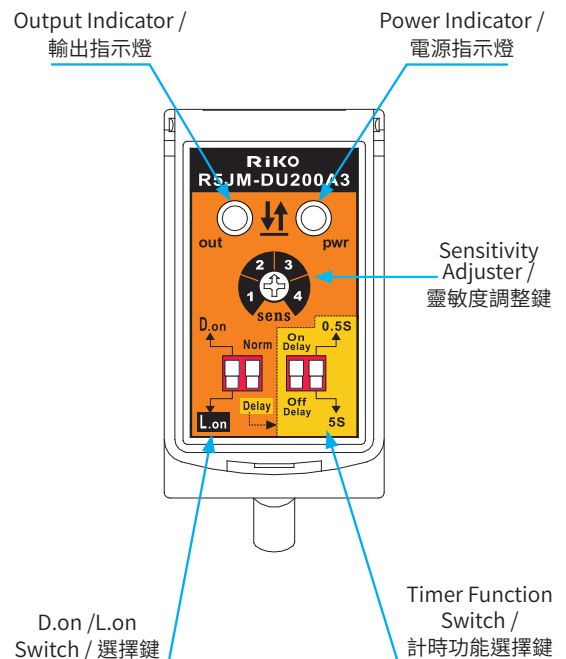

## Wiring diagrams / 接線圖

### A3 Out or Receiver

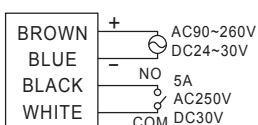

### A3 Emitter

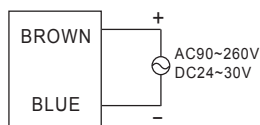

# 長距離檢測方形光電

# Long Sensing Range Photo Sensor

R3JK  
光電—光柵—超音波感測器

R5JM  
R3JK  
LK  
LRS  
PK3  
PKG3  
PK5  
PM6

PTQ18  
RMF  
MMF

SU07  
SU  
SU18  
SU30

SPR  
RX

OAP  
ASP

RU18

## Characteristic / 特點 :

- Aspherical optical lens.  
/ 非球面光學鏡片。
- Relay output.  
/ Relay輸出模式。
- Off-delay 0.2 second.  
/ Off-delay(0.2Sec.) 功能。



Model / 型號	R3JK-DU50A3 R3JK-DU100A3	R3JK-10A3 R3JK-30A3	R3JK-DU50KP2 R3JK-DU100KP2	R3JK-10KP2 R3JK-30KP2
		-	-	R3JK-DU50KP2K R3JK-DU100KP2K
Sensign type / 檢出方式	Diffuse reflection / 擴散反射式	Through beam / 對照式	Diffuse reflection / 擴散反射式	Through beam / 對照式
Sensign distance / 檢出距離	50cm, White paper 30x30cm 100cm, White paper 30x30cm	10M 30M	50cm, White paper 30x30cm 100cm, White paper 30x30cm	10M 30M
Emitting light / 發光源	Infrared LED 850 nm Infrared LED 940 nm	Infrared LED 850 nm	Infrared LED 940 nm	Infrared LED 850 nm
Operating voltage / 工作電壓	AC90 ~ 260V	DC24 ~ 30V	DC12 ~ 24 V	
Current Consumption / 消耗電流	25 mA Max.		30 mA Max.	
Load current / 負載電流	Relay : DC30V 5A/ AC250V 5A		100mA Max. at DC24V	
Output type / 輸出模式	Relay out : Com./NO.		NPN L.on/D.on PNP D.on/L.on	
Response time / 反應頻率	30 Hz		650 Hz	
Insulation resistance / 隔離阻抗	20MΩ min. (DC500V)			
Voltage withstandability / 絕緣耐壓	AC1000V 60Hz for 60 Sec.			
Operating temperature / 工作溫度	- 20 °C ~ + 60 °C ( No freezing allowed / 不可結霜, 結冰 )			
Ambient humidity / 工作溼度	35% ~ 85% RH			
Protection degree / 防水等級	IP65			
Option / 選購配件	M12R-PVC-2M / Mounting Bracket : R3JK-M001			
Material / 外觀材質	ABS			
Wiring method / 出線方式	R3JK-□A3/ KP2	(Receiver) Ø4.2 x 2 M / 4-wires (Emitter) Ø4.2 x 2 M / 2-wires		
	R3JK-□KP2K	M12 Pigtailed type / M12出線式接頭型		
Weight / 重量	R3JK-□A3/ KP2	85g	165g	80g
	R3JK-□KP2K	-	-	45g

## Dimensions / 尺寸圖 (mm)

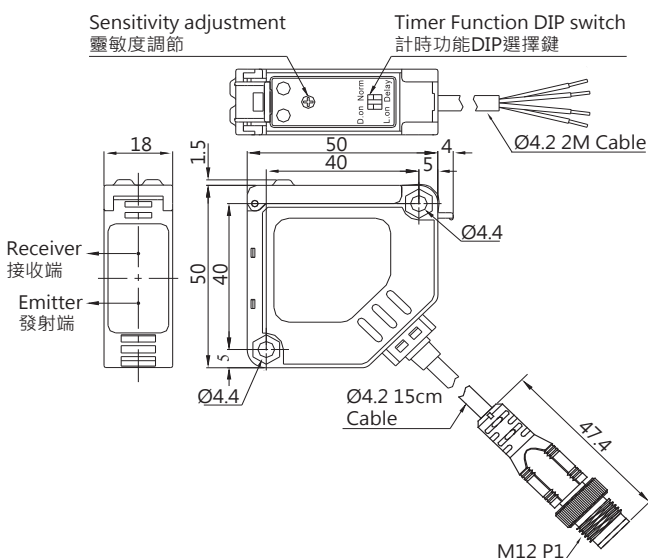

## Wiring diagrams / 接線圖

### A3 Output or Receiver

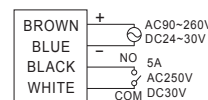

### A3 (Emitter)

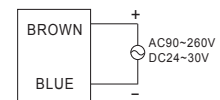

### KP2 Output or Receiver

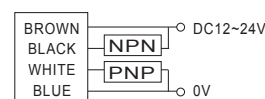

### KP2 (Emitter)

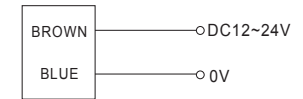

### KP2K Output or Receiver

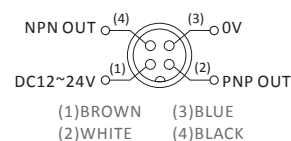

### KP2K (Emitter)

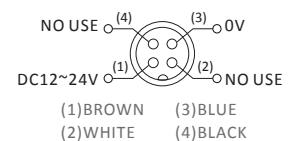

## Characteristic / 特點 :

- Aspherical optical lens.  
/ 非球面光學鏡片。
- Visible RED light for positioning.  
/ 可見紅光，方便調整對位。
- Off-delay 0.2 second.  
/ Off-delay(0.2Sec.) 功能。
- Special protective hood for dust-proof and greasiness-proof.  
/ 專用防塵蓋設計，可防灰塵及油污入侵。



R3JK

光電—光柵—超音波感測器

R5JM  
R3JK  
LK  
LRS  
PK3  
PKG3  
PK5  
PM6

PTQ18  
RMF  
MMF

SU07  
SU  
SU18  
SU30

SPR  
RX

OAP  
ASP

RU18

Model / 型號	R3JK-R5A3	R3JK-R5KP2	R3JK-QR2KP2	R3JK-PR2KP2
	-	R3JK-R5KP2K	R3JK-QR2KP2K	R3JK-PR2KP2K
Sensign type / 檢出方式	Retroreflective / 鏡片反射式		Retroreflective(RED) / 鏡片反射式(紅光)	Polarizing etroreflective / 光鏡片反射式
Sensign distance / 檢出距離	5M		2M	
Emitting light / 發光源	Infrared LED 940 nm		Red LED 650 nm	
Operating voltage / 工作電壓	AC90 ~ 260V DC24 ~ 30V		DC12 ~ 24 V	
Current Consumption / 消耗電流	25 mA Max.		30 mA Max.	
Load current / 負載電流	Relay: DC30V 5A / AC250V 5A		100mA Max. at DC24V	
Output type / 輸出模式	Relay out Com./NO.		NPN L.on/D.on PNP D.on/L.on	
Response time / 反應頻率	30 Hz		650 Hz	
Insulation resistance / 隔離阻抗	20MΩ min. (DC500V)			
Voltage withstandability / 絕緣耐壓	AC1000V 60Hz for 60 Sec.			
Operating temperature / 工作溫度	- 20 °C ~ + 60 °C ( No freezing allowed / 不可結霜，結冰 )			
Ambient humidity / 工作溼度	35% ~ 85% RH			
Protection degree / 防水等級	IP65			
Option / 選購配件	M124R-PVC-2M / Mounting Bracket : R3JK-M001			
Material / 外觀材質	ABS			
Wiring method / 出線方式	R3JK-□A3/ KP2		Pre-wired Ø4.2 x 2 M / 4-wires	
	R3JK-□KP2K		M12 Pigtailed type / M12出線式接頭型	
Weigh / 重量	R3JK-□A3/ KP2		85g	
	R3JK-□KP2K		- 45g	

## Dimensions / 尺寸圖 (mm)

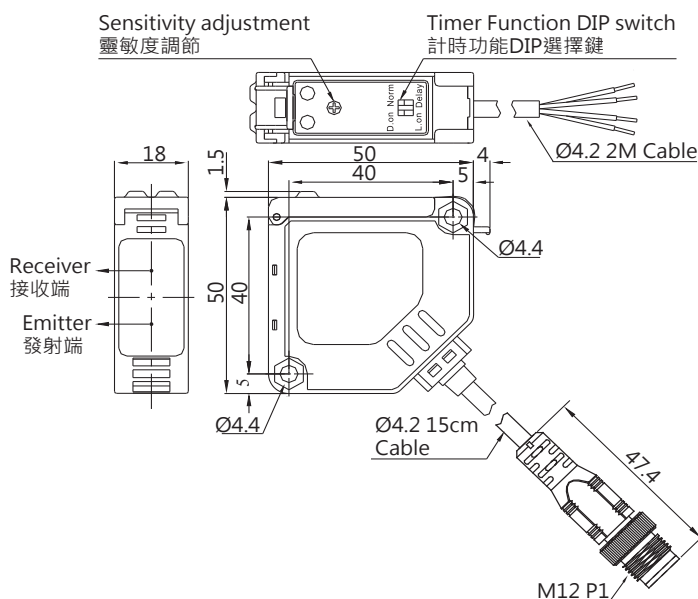

## Wiring diagrams / 接線圖

### A3 (Emitter)

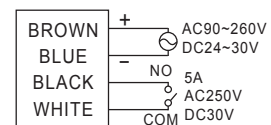

### KP2 (Emitter)

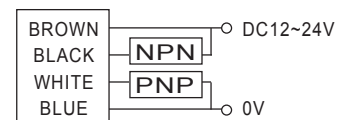

### KP2K (Emitter)

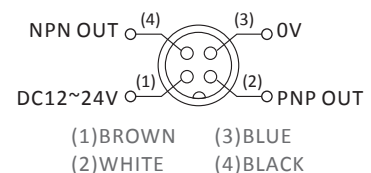

# 長距離檢測方形光電

## Long Sensing Range Photo Sensor

### • Clearly visible red LED (QR series) / 清晰可見的紅光LED(QR系列)

The visible red LED is available at the distance of 1M. It is easy for your installation and detection. 使用紅光LED，即使在1M的距離，一樣可以清楚的看見紅光，讓您在安裝檢測時更方便。

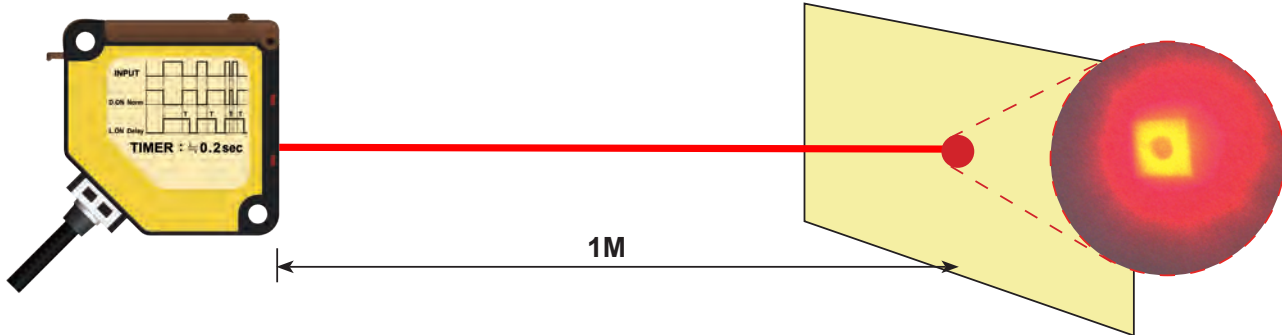

### • Special design of protective hood for dust-proof / 專用防塵蓋設計

With special protective hood for dust-proof, it can avoid the breakdown caused by dust or spray. 附有特殊專用防塵蓋，可以防塵也可防水濺射浸入造成短路傷害。

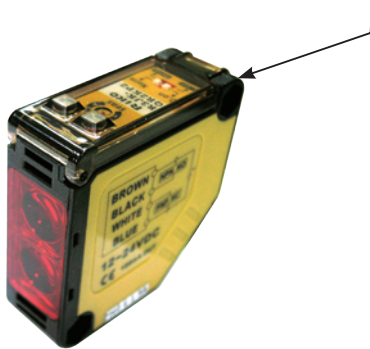

### • Import high switching capability relay. / 進口大容量繼電器

Import relay is with 0.2 Sec. delay function and can be switched L.on/D.on directly. 附有0.2秒延遲功能可供選擇，另外入光輸出/遮光輸出，可以直接在面板切換。

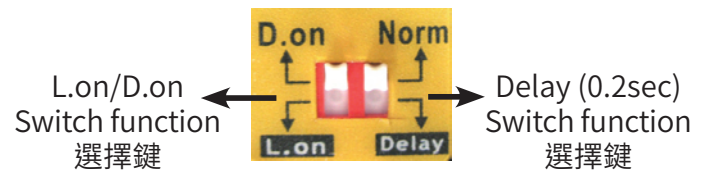

### • Non-spherical optical lens / 非球面光學鏡片

For a better focusing, with the exceptional optical lens. 使用品質優良的透鏡達到更好的聚焦。



Special optical lens  
特殊光學鏡頭

### • Dual LED indicator / 雙LED指示燈

Visible dual LED makes you easy to know the current operating situation. 明亮的雙LED燈可以讓使用者更容易了解目前動作狀況。



### • Sensitivity adjuster / 可調式旋鈕

Users can adjust the sensitivity more optimum according to different situations. 根據不同場合，使用者可以調整合適感度。



R3JK

光電 / 光柵 / 超音波感測器

R5JM  
R3JK  
LK  
LRS  
PK3  
PKG3  
PK5  
PM6

PTQ18  
RMF  
MMF

SU07  
SU  
SU18  
SU30

SPR  
RX

OAP  
ASP

RU18

## Characteristic / 特點：

- Visible dual LED makes it easy to know the current operating situation. / 雙LED指示燈，容易辨別動作情形。
- Standard screw hole 25.4mm. / 標準規格25.4mm螺絲固定孔間距。
- Compact size (W12xH31xD20mm), space saving. / 尺寸輕巧(W12xH31xD20mm)，省空間。
- Clearly visible red laser. / 清晰可見的紅光雷射。



LK3

光電 / 光柵 / 超音波感測器

R5JM  
R3JK  
LK  
LRS  
PK3  
PKG3  
PK5  
PM6

PTQ18  
RMF  
MMF

SU07  
SU  
SU18  
SU30

SPR  
RX

OAP  
ASP

RU18

Model / 型號	LK3-DU10N3
	LK3-DU10P3
Sensing type / 檢出方式	Reflection / 光點反射式
Operating distance / 檢測距離	2-10 cm ±10% (White paper / 白紙)
Emitted light / 發光源	Red laser / 紅光雷射 650 nm
Laser class / 雷射光等級	2
Operating voltage / 工作電壓	12~ 24 VDC
Current Consumption / 消耗電流	最大 25mA
Load current / 負載電流	最大 100 mA at DC 24V
Diameter of light spot / 光點直徑	2mm
Output / 輸出模式	NPN L.on/D.on PNP L.on/D.on
Response time / 反應頻率	1000 Hz
Insulation resistance/ 隔離阻抗	最小 20M ohm (DC 500V)
Voltage withstandability / 絕緣耐壓	AC 1000V 60Hz 持續 60 sec
Operating temperature / 工作溫度	-10°C ~ + 50°C
Ambient humidity/ 工作濕度	35% - 85% RH
Protection degree / 防護等級	IP64
Casing material / 外殼材料	ABS+PC
Wiring method / 出線方式	Pre-wired Ø4.2 x 2M / 3-wires
Weight / 重量	20g

## Dimensions / 尺寸圖 (mm)

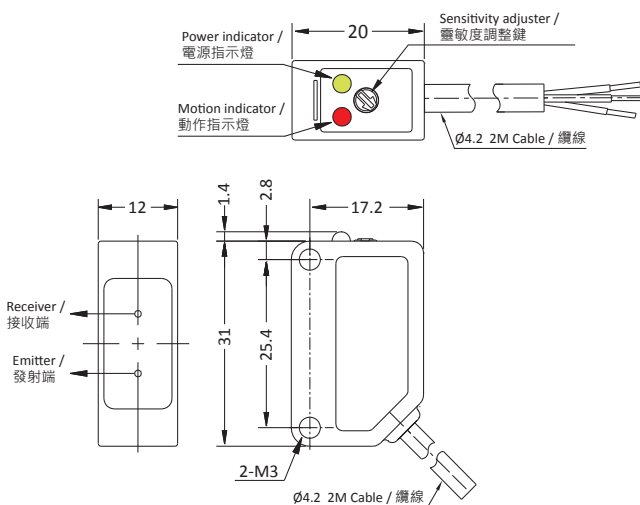

## Wiring diagrams / 接線圖

N3

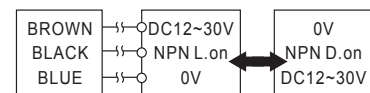

P3

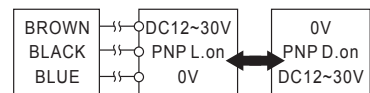

## Clearly visible red laser / 清晰可見的紅光雷射

使用雷射光，可以清楚的看見光點，讓使用者在安裝檢測時更方便。

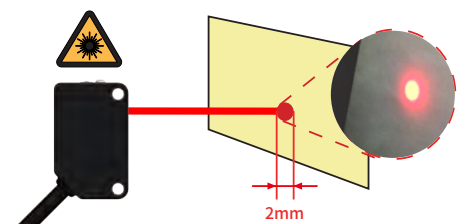

# M18 雷射光電

# M18 Laser Photo Sensor

## Characteristic / 特點：

- Class 1 laser.  
/ 雷射等級 1。
- Small light spot 0.5mm (range of 100mm).  
/ 最小光點 0.5mm (100mm以內)。
- One button teaching.  
/ 單鍵教導按鍵。
- Protection rating IP67.  
/ 防水等級 IP67。



Model / 型號	LK18-DU30-B3	LK18-DU30-P3	LK18-DU30-B3-K1	LK18-DU30-P3-K1
Nominal sensing distance / 感應距離	300 mm (axial optic focused 100 mm) <sup>1</sup>			
Emission / 光源	red laser diode (650 nm) class 1 laser (IEC60825-1)			
Minimum detectable object / 最小檢測物	0.5 mm			
Operating voltage / 工作電壓	10 ~ 30 Vdc			
Ripple / 漣波因數	≤ 10 %			
Load current / 負載電流	100 mA			
Output type / 輸出	NPN or PNP ; NO + NC			
Response time / 反應時間	800 Hz / 1.3 ms			
Power supply protections / 電源保護	polarity reversal, transient			
Output protection / 輸出保護	short circuit (autoreset) Overvoltage			
Sensitivity adjustment / 感度調整	Teach-in / 感度調整按鈕			
Operating temperature / 工作溫度	-15°C ~ +55°C (without freeze)			
Protection rating / 防水等級	IP 67 (EN60529) <sup>2</sup>			
External light interference / 抗外亂光	3,000 lux (incandescent lamp) 10,000 lux (sunlight)			
LEDs / 燈號	green power supply / yellow (ON-Light state EG ≥ 2) / yellow (Flashing-Light state 1 < EG < 2) / yellow (OFF-Dark state)			
Housing material / 外殼	PBT (plastic) / PC (cable exit)			
Optic material / 光學材質	PC			
Tightening torque / 扭緊力距	1 Nm (plastic)			
Weight / 重量	plastic version: 30 g connector / 50 g cable			

## Wiring diagrams / 接線圖

### NPN NO+NC Output

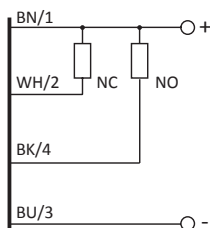

### PNP NO+NC Output

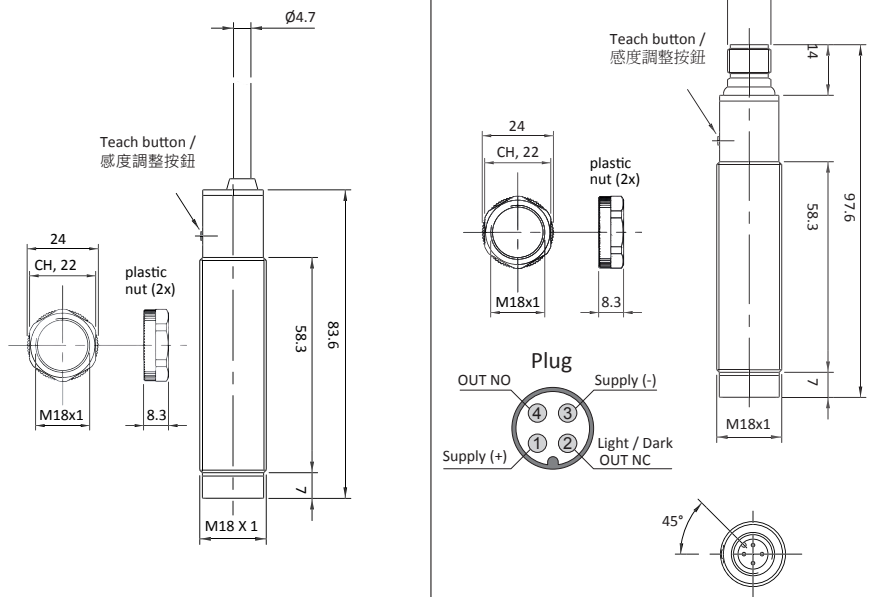
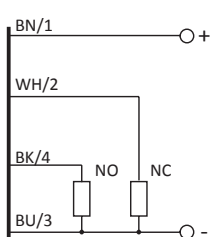

<sup>1</sup> White target kodak 90% reflection 100 X 100 mm.

<sup>2</sup> Protection guaranteed only with plug cable well mounted

LK18

光電 / 光柵 / 超音波感測器

R5JM  
R3JK  
LK  
LRS  
PK3  
PKG3  
PK5  
PM6

PTQ18  
RMF  
MMF

SU07  
SU  
SU18  
SU30

SPR  
RX

OAP  
ASP

RU18

## Characteristic / 特點：

- Class 1 laser.  
/ 雷射等級 1。
- Small light spot 0.7mm (range of 1M).  
/ 最小光點 0.7mm (1M 以內)。
- One button teaching.  
/ 單鍵教導按鍵。
- Protection rating IP67.  
/ 防水等級 IP67。

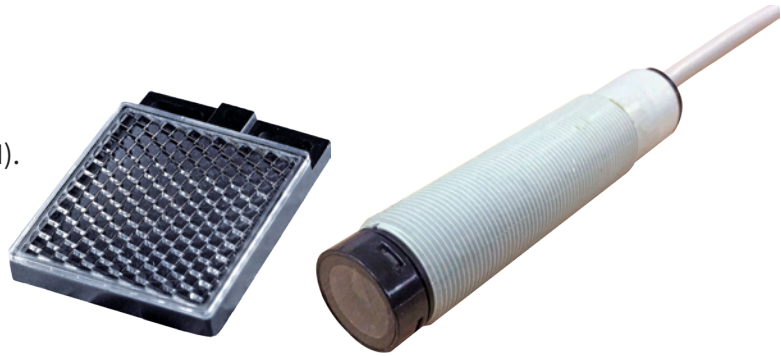

LK18

光電 / 光柵 / 超音波感測器

R5JM  
R3JK  
LK  
LRS  
PK3  
PKG3  
PK5  
PM6

PTQ18  
RMF  
MMF

SU07  
SU  
SU18  
SU30

SPR  
RX

OAP  
ASP

RU18

Model / 型號	LK18-R5B3	LK18-R5P3	LK18-R5B3-K1	LK18-R5P3-K1
Nominal sensing distance / 感應距離	5M			
Emission / 光源	red laser diode (650 nm) class 1 laser (IEC60825-1)			
Minimum detectable object / 最小檢測物	1 mm - ( 1 M )			
Operating voltage / 工作電壓	10 ~ 30 Vdc			
Ripple / 漣波因數	≤ 10 %			
Load current / 負載電流	100 mA			
Output type / 輸出	NPN or PNP ; NO + NC			
Response time / 反應時間	800 Hz / 1.3 ms			
Power supply protections / 電源保護	polarity reversal, transient			
Output protection / 輸出保護	short circuit (autoreset) Overvoltage			
Sensitivity adjustment / 感度調整	Teach-in / 感度調整按鈕			
Operating temperature / 工作溫度	-15°C ~ + 55°C (without freeze)			
Protection rating / 防水等級	IP 67 (EN60529)			
External light interference / 抗外亂光	3,000 lux (incandescent lamp) 10,000 lux (sunlight)			
LEDs / 燈號	green power supply / yellow (ON-Light state EG ≥ 2) / yellow (Flashing-Light state 1 < EG < 2) / yellow ( OFF-Dark state)			
Housing material / 外殼	PBT (plastic) / PC (cable exit)			
Optic material / 光學材質	PC			
Tightening torque / 扭緊力距	1 Nm (plastic)			
Weight / 重量	plastic version: 30 g connector / 50 g cable			

## Wiring diagrams / 接線圖

### NPN NO+NC Output

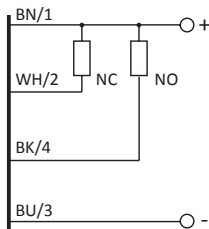

### PNP NO+NC Output

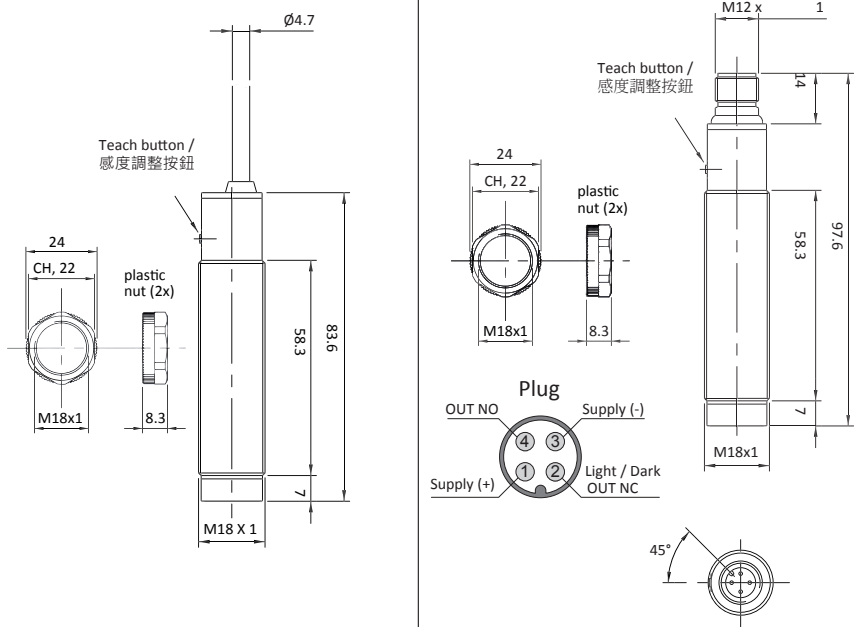
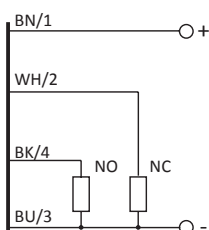

## Response diagram

direct diffuse models

### LK18 擴散反射式

Excess gain / 增益

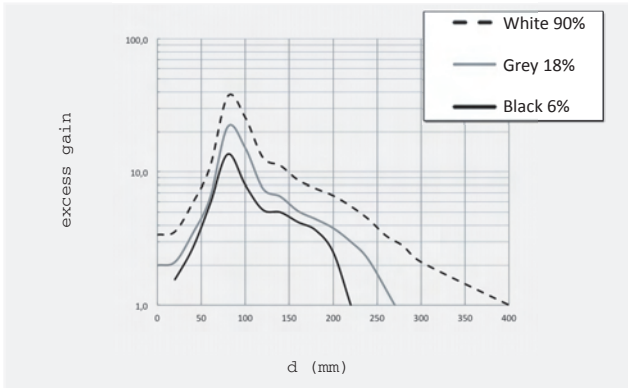

Spot dimension / 光點尺寸

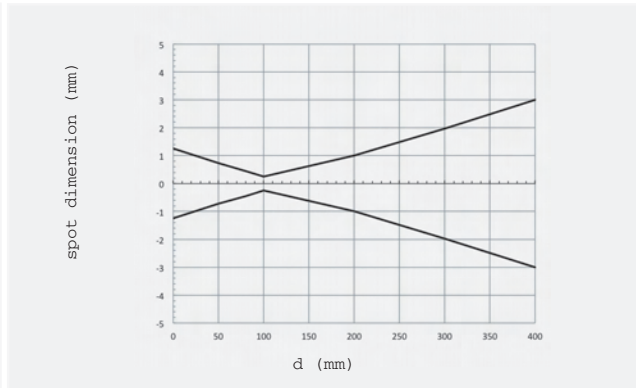

Parallel displacement / 水平移動

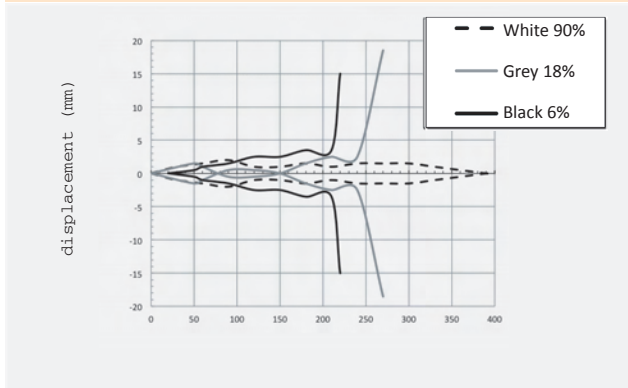

### LK18-R5 鏡片反射式

Excess gain / 增益

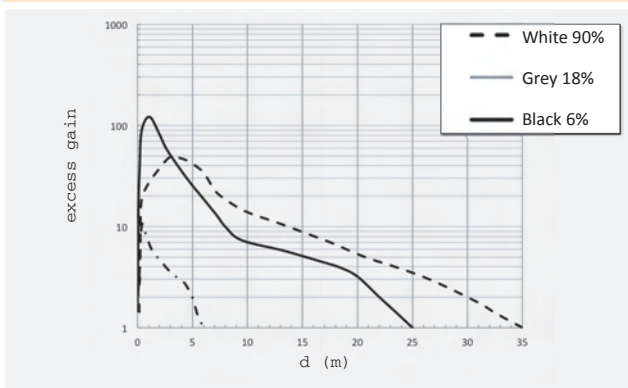

Spot dimension / 光點尺寸

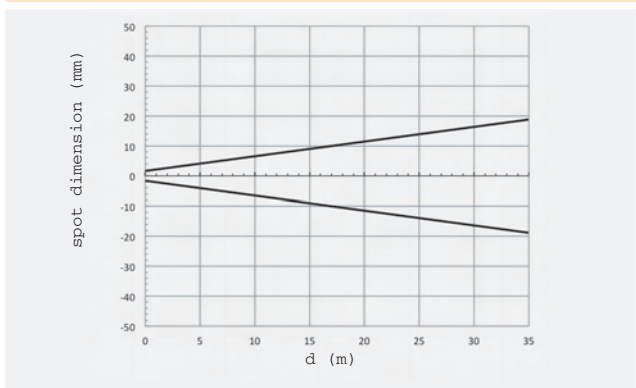

Parallel displacement / 水平移動

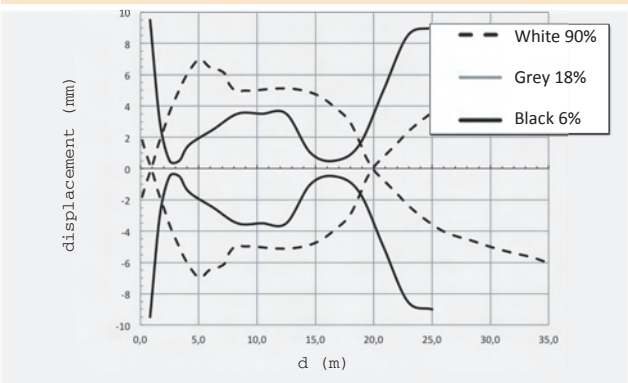

LK18

光電 / 光柵 / 超音波感測器

R5JM  
R3JK  
LK  
LRS  
PK3  
PKG3  
PK5  
PM6

PTQ18  
RMF  
MMF

SU07  
SU  
SU18  
SU30

SPR  
RX

OAP  
ASP

RU18

## Characteristic / 特點：

- OLED Graphic Display . / OLED 數位顯示。
- 90° Rotating Connector. / 90° 可旋轉接頭。
- NPN and PNP Outputs. / NPN/PNP 輸出。
- Threshold and Set-Point Numeric Graphic & delay Timers, One Shot & Sensor Scope Diagnostics. / 螢幕顯示門檻值, 設定值, 延遲設定狀態, 對比指標位置。
- Built-in Digital Instructions. / 內建簡單設定敘述。



LRS

光電 / 光柵 / 超音波感測器

R5JM  
R3JK  
LK  
LRS  
PK3  
PKG3  
PK5  
PM6

PTQ18  
RMF  
MMF

SU07  
SU  
SU18  
SU30

SPR  
RX

OAP  
ASP

RU18

Model / 型號	LRS-DU10-NP	LRS-DU40-NP
Sensing type / 檢出方式	Diffuse reflection / 擴散反射式	
Operating distance / 檢測距離	100 mm	400 mm
Emitted light / 發光源	Red laser / 紅色雷射 650 nm	
Operating voltage / 工作電壓	10~ 30 VDC	
Output / 輸出模式	NPN / PNP L.on / D.on	
Response time / 反應時間	240 μs	
Operating principle / 操作原理	漫反射	
Laser class / 雷射光等級	Class 1	Class 2
Voltage drop / 壓降	最大 35mA, 24VDC	
Operating temperature / 工作溫度	-40°C ~ 70°C	
Protection degree / 防護等級	IP67	
Casing material / 外殼材料	ABS 塑殼	
Connection / 連接方式	Connector M12 5-poled (M125R-PUR-2M)	

## Dimensions / 尺寸圖 (mm)

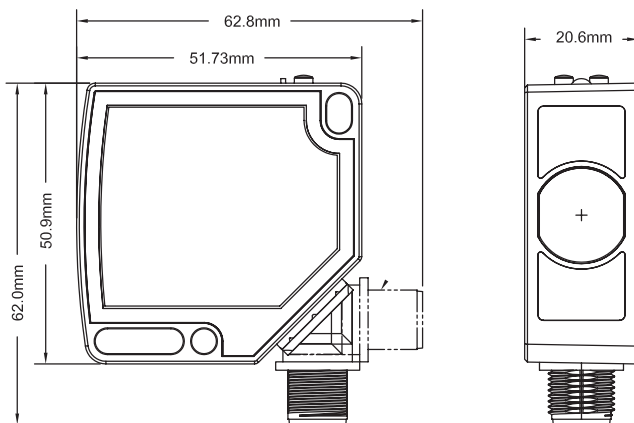

## Wiring diagrams / 接線圖

-NP

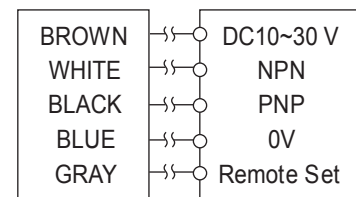

# 小方形光電

# Miniature Photo Sensor

PK3

光電一光柵一超音波感測器

R5JM  
R3JK  
LK  
LRS  
PK3

PKG3  
PK5  
PM6

PTQ18  
RMF  
MMF

SU07  
SU  
SU18  
SU30

SPR  
RX

OAP  
ASP

RU18

## Characteristic / 特點：

- Standard screw hole 25.4mm.  
/ 標準規格 25.4mm螺絲固定孔"間距"。
- Visible dual LED makes it easy to know the current operating situation.  
/ 雙LED指示燈，容易辨別動作情形。
- Compact size (W12xH31xD20mm), space saving.  
/ 尺寸輕巧(W12xH31xD20mm)，省空間。
- Single output available by request.  
/ 單輸出可另行訂製。



Model / 型號	Pre-wired Ø4.2	PK3-DU20NP	PK3-DU50NP
	M8 Pigtailed type	PK3-DU20NPB	PK3-DU50NPB
Sensing type / 檢出方式	Diffuse reflection / 擴散反射式		
Sensing distance / 檢出距離	20 cm , 白畫紙 10 x 10 cm		50 cm , 白畫紙 10 x 10 cm
Emitting light / 發光源	Infrared LED 850 nm		
Operating voltage / 工作電壓	DC12 ~ 24 V		
Current Consumption / 消耗電流	25 mA Max.		
Load current / 負載電流	100mA Max. at DC24V		
Output type / 輸出模式	NPN / PNP : L.on / D.on		
Response time / 反應頻率	1000 Hz		
Insulation resistance / 隔離阻抗	20MΩ min. (DC500V)		
Voltage withstandability / 絕緣耐壓	AC1000V 60Hz for 60 Sec.		
Operating temperature / 工作溫度	- 20 °C ~ + 60 °C (不可結霜, 結冰)		
Ambient humidity / 工作溼度	35% ~ 85% RH		
Protection degree / 防水等級	IP64		
Option / 選購配件	Mounting Bracket / PK-M001 M84R-2M-PVC / M84RL-2M PVC		
Material / 外觀材質	ABS		
Wiring method / 出線方式	PK3-□NP	Pre-wired Ø4.2 x 2 M / 4-wires	
	PK3-□B	M8 pigtailed connector type	
Weight / 重量	PK3-□NP	60g	
	PK3-□B	20g	

## Dimensions / 尺寸圖 (mm)

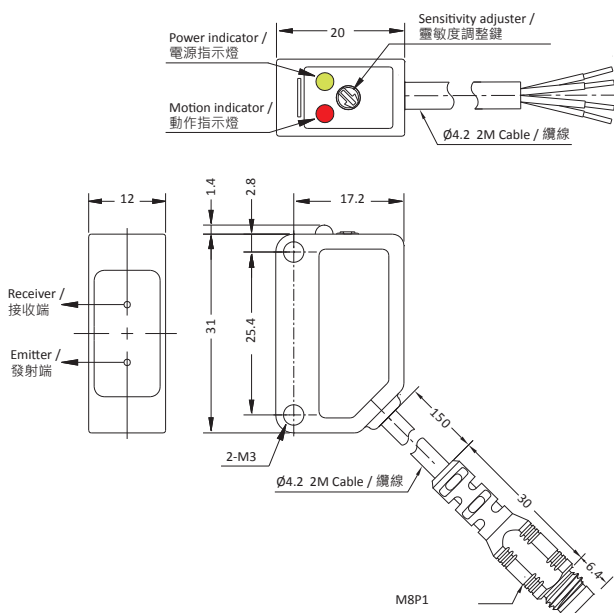

## Wiring diagrams / 接線圖

### NP Output

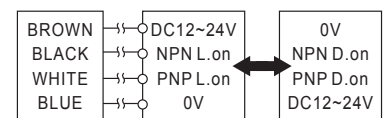

### NPB Output

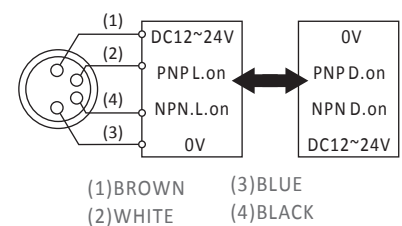

## Characteristic / 特點：

- Standard screw hole 25.4mm.  
/ 標準規格 25.4mm 螺絲固定孔 "間距"。
- Visible dual LED makes it easy to know the current operating situation.  
/ 雙LED指示燈，容易辨別動作情形。
- Compact size (W12xH31xD20mm), space saving.  
/ 尺寸輕巧(W12xH31xD20mm)，省空間。



PK3

光電 / 光柵 / 超音波感測器

R5JM  
R3JK  
LK  
LRS  
PK3

PKG3  
PK5  
PM6

PTQ18  
RMF  
MMF

SU07  
SU  
SU18  
SU30

SPR  
RX

OAP  
ASP

RU18

Model / 型號	Pre-wired Ø4.2	PK3-5N	PK3-5P
	M8 Pigtailed type	PK3-5NB	PK3-5PB
Sensing type / 檢出方式		Through beam / 對照式	
Sensing distance / 檢出距離		5M	
Emitting light / 發光源		Infrared LED 875 nm	
Operating voltage / 工作電壓		DC12 ~ 24 V	
Current Consumption / 消耗電流		40 mA Max.	
Load current / 負載電流		100mA Max. at DC24V	
Output type / 輸出模式		N: NPN L.on/D.on P: PNP L.on/D.on	
Response time / 反應頻率		650 Hz	
Insulation resistance / 隔離阻抗		20MΩ min. (DC500V)	
Voltage withstandability / 絕緣耐壓		AC1000V 60Hz for 60 Sec.	
Operating temperature / 工作溫度		- 20 °C ~ + 60 °C (不可結霜, 結冰)	
Ambient humidity / 工作溼度		35% ~ 85% RH	
Protection degree / 防水等級		IP64	
Option / 選購配件		Mounting Bracket / PK-M001 M84R-2M-PVC / M84RL-2M PVC	
Material / 外觀材質		ABS	
Wiring method / 出線方式	PK3-□N/P	(Receiver) Ø4.2 x 2 M / 4-wires / (Emitter) Ø4.2 x 2 M / 2-wires	
	PK3-□B	M8 pigtailed connector type / M8 出線式接頭型	
Weight / 重量	PK3-□N/P	115g	
	PK3-□B	40g	

## Dimensions / 尺寸圖 (mm)

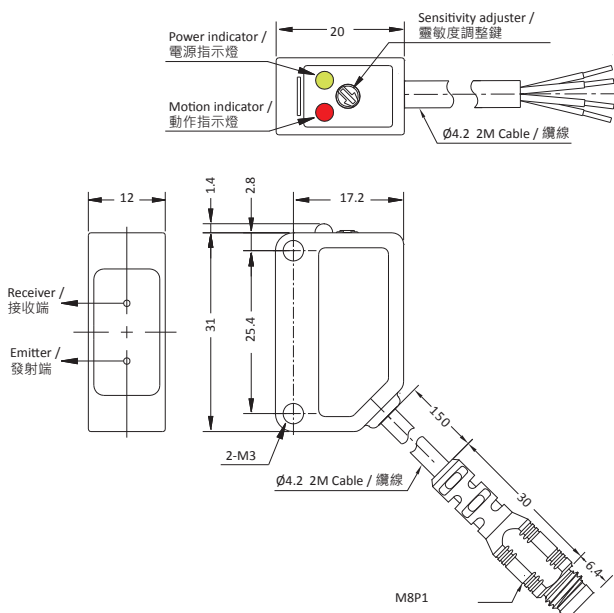

## Wiring diagrams / 接線圖

### N Output

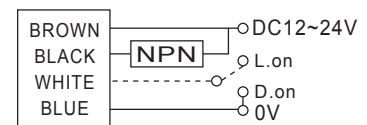

### PB Output

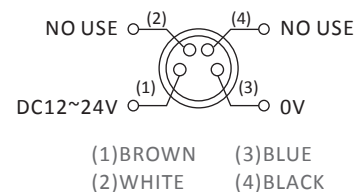

# 小方形光電

# Miniature Photo Sensor

PK3

光電 / 光柵 / 超音波感測器

R5JM  
R3JK  
LK  
LRS

PK3  
PKG3  
PK5  
PM6

PTQ18  
RMF  
MMF

SU07  
SU  
SU18  
SU30

SPR  
RX

OAP  
ASP

RU18

## Characteristic / 特點：

- Standard screw hole 25.4mm.  
/ 標準規格 25.4mm 螺絲固定孔 "間距"。
- Visible dual LED makes it easy to know the current operating situation.  
/ 雙LED指示燈，容易辨別動作情形。
- Compact size (W12xH31xD20mm), space saving.  
/ 尺寸輕巧(W12xH31xD20mm)，省空間。



Model / 型號	Pre-wired Ø4.2	PK3-R2N	PK3-R2P	PK3-QM1N	PK3-QM1P
	M8 Pigtailed type	PK3-R2NB	PK3-R2PB	PK3-QM1NB	PK3-QM1PB
Sensing type / 檢出方式		Retroreflective / 鏡片反射式		Retroreflective (Red LED) / 鏡片反射式 (紅光)	
Sensing distance / 檢出距離		2M		2M	
Emitting light / 發光源		Infrared LED 850 nm		Red LED 660 nm	
Operating voltage / 工作電壓		DC12 ~ 24 V			
Current Consumption / 消耗電流		35 mA Max.		20 mA Max.	
Load current / 負載電流		100mA Max. at DC24V			
Output type / 輸出模式		N: NPN L.on/D.on P: PNP L.on/D.on			
Response time / 反應頻率		650 Hz		1000 Hz	
Insulation resistance / 隔離阻抗		20MΩ min. (DC500V)			
Voltage withstandability / 絕緣耐壓		AC1000V 60Hz for 60 Sec.			
Operating temperature / 工作溫度		- 20 °C ~ + 60°C (不可結霜，結冰)			
Ambient humidity / 工作溼度		35% ~ 85% RH			
Protection degree / 防水等級		IP64			
Option / 選購配件		Mounting Bracket / PK-M001 M84R-2M-PVC / M84RL-2M PVC			
Material / 外觀材質		ABS			
Wiring method / 出線方式	PK3-□N/P/NP	Pre-wired Ø4.2 x 2 M / 4-wires			
	PK3-□B	M8 pigtailed connector type / M8 出線式接頭型			
Weight / 重量	PK3-□N/P/NP	60g			
	PK3-□B	20g			

## Dimensions / 尺寸圖 (mm)

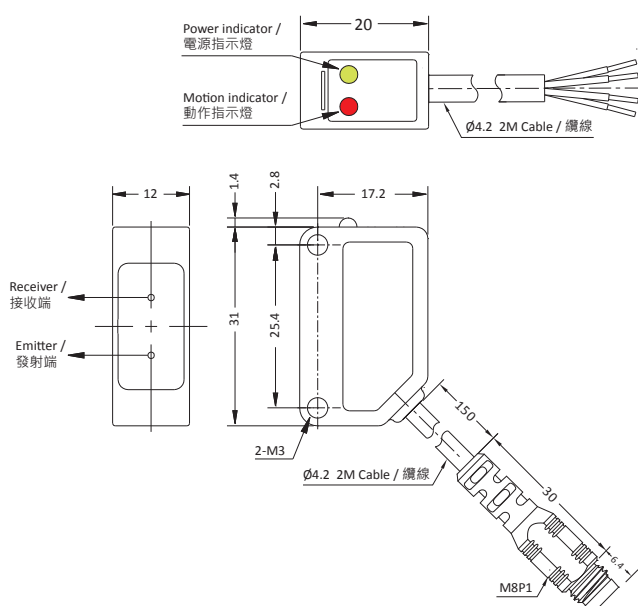

## With reflector, sensing distance 0.05~2m 鏡片0.05~2m可感應 (QM系列)

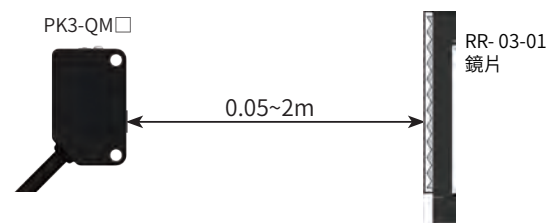

## Characteristic / 特點：

- Overmoulding pre-wired cable, One-mold design.  
/ 包覆射出，一體成型，堅固耐用。
- Convergent reflective with potentiometer.  
/ 限定距離可調式機種，可依不同情況而有所調整。



PK3

光電 / 光柵 / 超音波感測器

R5JM  
R3JK  
LK  
LRS  
PK3

PKG3  
PK5  
PM6

PTQ18  
RMF  
MMF

SU07  
SU  
SU18  
SU30

SPR  
RX

OAP  
ASP

RU18

Model / 型號	Pre-wired Ø4.2	PK3-V05N	PK3-V05P	PK3-V10N	PK3-V10P
	M8 Pigtailed type	PK3-V05NB	PK3-V05PB	PK3-V10NB	PK3-V10PB
Sensing type / 檢出方式	Convergent reflection type / 限定距離反射型				
Sensing distance / 檢出距離	7 cm , White paper / 白紙 10 x 10 cm		10 cm , Black paper / 黑色塑膠片		
Emitting light / 發光源	Infrared LED 850 nm				
Operating voltage / 工作電壓	DC12 ~ 24 V				
Current Consumption / 消耗電流	20 mA Max.				
Load current / 負載電流	100mA Max. at DC24V				
Output type / 輸出模式	NPN L.on/D.on	PNP L.on/D.on	NPN L.on/D.on	PNP L.on/D.on	
Response time / 反應頻率	650 Hz				
Insulation resistance / 隔離阻抗	20MΩ min. (DC500V)				
Voltage withstandability / 絕緣耐壓	AC1000V 60Hz for 60 Sec.				
Operating temperature / 工作溫度	- 20 °C ~ + 60°C (不可結霜, 結冰)				
Ambient humidity / 工作溼度	35% ~ 85% RH				
Protection degree / 防水等級	IP64				
Option / 選購配件	Mounting Bracket / PK-M001 M84R-2M-PVC / M84RL-2M PVC				
Material / 外觀材質	ABS + PC				
Wiring method / 出線方式	PK3-□N/P	Pre-wired Ø4.2 x 2 M / 4-wires			
	PK3-□B	M8 pigtailed connector type / M8 出線式接頭型			
Weight / 重量	PK3-□N/P	60g			PK3-□B
	PK3-□B	20g			

## Dimensions / 尺寸圖 (mm)

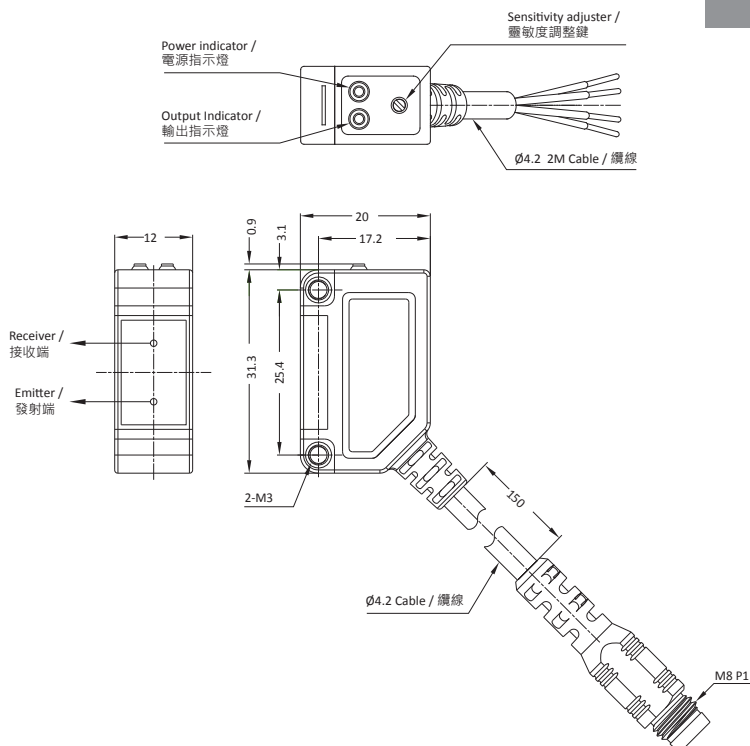

## PK3-V05 & PK3-V10 detecting different materials / PK3-V05 & PK3-V10 檢測不同材質

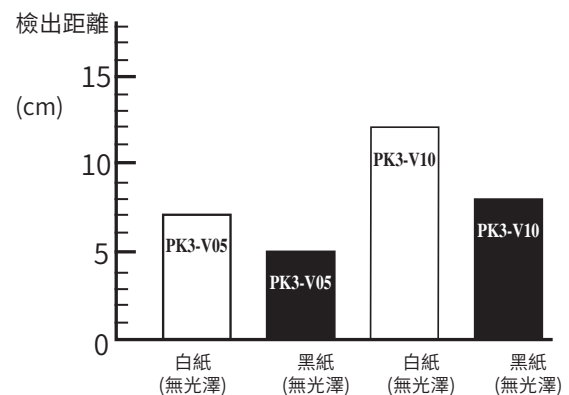

### • Dual LED indicator / 雙LED指示燈

Visible dual LED makes you easy to know the current operating situation.

明亮的雙LED燈可以讓使用者更容易了解目前動作狀況。



### • Non-spherical optical lens / 非球面光學鏡片

For a better focusing, with the exceptional optical lens.

使用品質優良的透鏡，達到更好的聚焦。

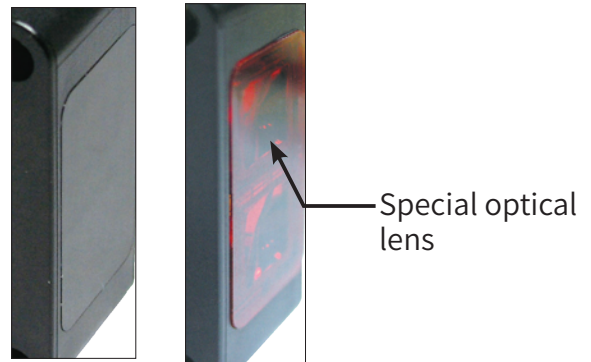

### • Flexible Mounting / 堅固易安裝

Embedded brass screw hole, easy mounting and no damage to the body.

嵌入黃銅螺絲孔更容易安裝，而且無損感測器本體。

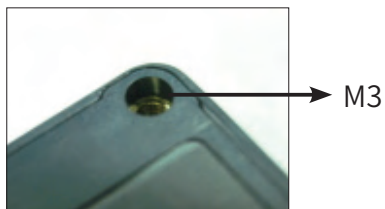

PK3

光電—光柵—超音波感測器

R5JM  
R3JK  
LK  
LRS

PK3  
PKG3  
PK5  
PM6

PTQ18  
RMF  
MMF

SU07  
SU  
SU18  
SU30

SPR  
RX

OAP  
ASP

RU18

## Characteristic / 特點：

- Mechanical background suppression.  
/ 機械背景抑制。
- Visible red light with small light spot.  
/ 可視的紅光小光點。
- Sensitivity adjustable.  
/ 靈敏度可調。
- Dark-/light switching.  
/ D.on/L.on, 可切換。
- Standard screw hole 25.4mm.  
/ 標準規格 25.4mm 螺絲固定孔。



PKG3

光電 / 光柵 / 超音波感測器

R5JM  
R3JK  
LK  
LRS  
PK3  
PKG3  
PK5  
PM6

PTQ18  
RMF  
MMF

SU07  
SU  
SU18  
SU30

SPR  
RX

OAP  
ASP

RU18

Model / 型號	PKG3-DU20N	PKG3-DU20P
Sensing type / 檢出方式	Diffuse reflection type / 漫反射式	
Emitted light / 發光源	Visible red light / 紅光, 630nm	
Standardized measuring plate / 標準化的測量板	200 x 200 mm, white	
Operating voltage / 工作電壓	10~30 VDC	
Internal power consumption / 內部功耗	< 30 mA	
background suppression / 背景抑制	Yes / 是	
Operating distance / 工作距離	30~200mm	
Output / 輸出模式	NPN	PNP
	100 mA, NO/NC, 可切換 Switchable	
Switching hysteresis / 開關滯後	< 10 %	
Voltage drop / 壓降	< 2.0 V	
Switching frequency / 工作頻率	1,000 Hz	
Response/release time/反應頻率/釋放時間	< 0.5 ms / < 0.5 ms	
Operating temperature / 工作溫度	-25°C ~ 70°C	
Ambient light immunity / 環境光免疫	3 kLx Bulb light / 鹵素燈, 10 kLx Tube light / 日光燈	
Protection degree / 防護等級	IP67	
Casing material / 外殼材料	PA66 Plastic housing / 塑殼	
Connection / 連接方式	Cable, 2,0 m, 3-poled, flying leads	

## Dimensions / 尺寸圖 (mm)

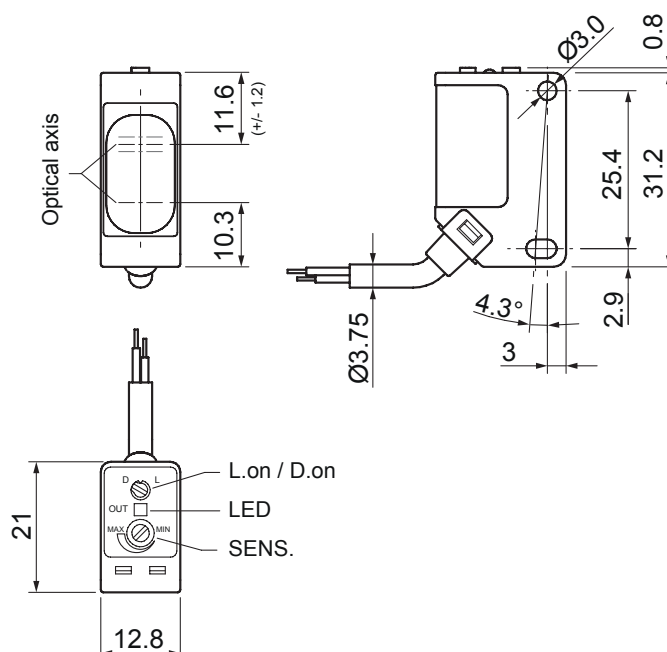

# 微小薄形光電

# Miniature Photo Sensor

PK5

光電 / 光柵 / 超音波感測器

R5JM  
R3JK  
LK  
LRS  
PK3  
PKG3  
PK5  
PM6

PTQ18  
RMF  
MMF

SU07  
SU  
SU18  
SU30

SPR  
RX

OAP  
ASP

RU18

## Characteristic / 特點：

- Ultra slim body (only 3.5mm thickness).  
Easy to be mounted.  
/ 超薄體積(3.5mm)，容易安裝。
- Application: Narrow space sensing.  
/ 適合狹小空間檢測物體。
- Visible contracted beam, easy for recognition.  
/ 光點集中，方便識別。

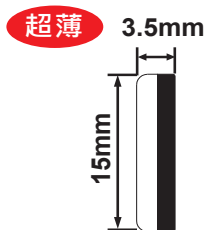

Model / 型號	PK5-DU03N	PK5-F05N	PK5-1N	PK5-1N2
	PK5-DU03P	PK5-F05P	PK5-1P	PK5-1P2
Sensing type / 檢出方式	Diffuse reflection / 擴散反射式		Through beam / 對照式	
Sensing distance / 檢出距離	3 cm, White paper 10x10 cm		5 cm, White paper 10x10 cm	
Emitting light / 發光源	Red LED 632 nm		Infrared LED 940nm	
Operating voltage / 工作電壓	DC12 ~ 24 V ± 10% (Ripple P-P : 10% Max.)			
Current Consumption / 消耗電流	15 mA Max.			
Load current / 負載電流	100mA Max. at DC24V			
Output type / 輸出模式	N : NPN L.on P : PNP L.on		N : NPN D.on P : PNP D.on	N : NPN L.on P : PNP L.on
Protection circuit / 保護電路	Reversed supply circuit protection, short circuit protection output. / 電源反接保護及輸出短路保護			
Response time / 反應頻率	2000 Hz			
Insulation resistance / 隔離阻抗	20MΩ min. (DC500V)			
Voltage withstandability / 絕緣耐壓	AC1000V 60Hz for 60 Sec.			
Operating temperature / 工作溫度	-10°C ~ +45°C ( No freezing allowed 不可結霜, 結冰 )			
Ambient humidity / 工作溼度	35% ~ 85% RH 相對溼度			
Storage temperature / 儲存時溫度	-10°C ~ +55°C ( No freezing allowed 不可結霜, 結冰 )			
Storage humidity / 儲存時溼度	35% ~ 95% RH 相對溼度			
Protection degree / 防水等級	IP64	IP65	IP64	
Material / 外觀材質	ABS			
Wiring method / 出線方式	Ø2.4 x 2 M / 3-wires		(Receiver) Ø2.4 x 2 M / 3-wires / (Emitter) Ø2.4 x 2 M / 2-wires	
Option / 選購配件	Bracket / 固定架 : PK5/PM6 Mounting Bracket			
Weight / 重量	20g		40g	

## Dimensions / 尺寸圖 (mm)

### • PK5-DU03N/P

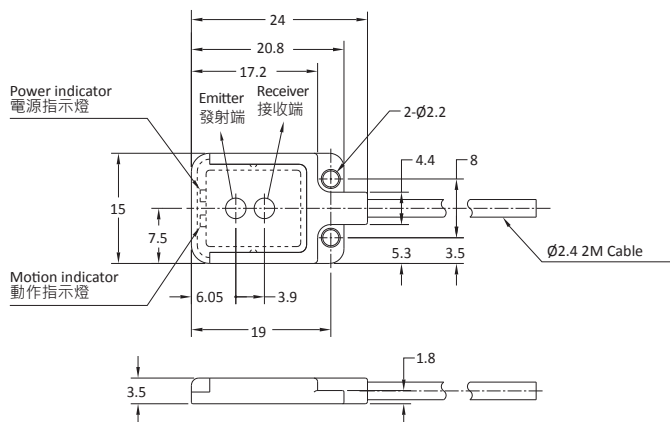

### • PK5-1N/P

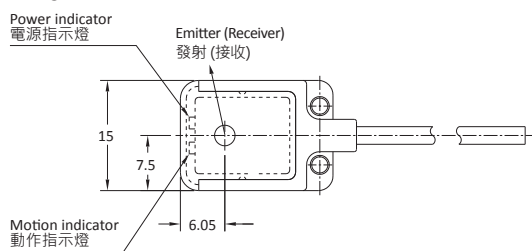

### • PK5-F05N/P

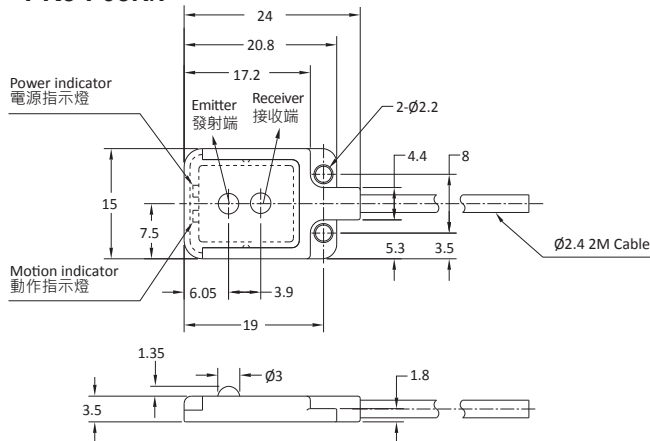

## Characteristic / 特點：

- Focused small light stop easy to detect tiny objects.  
/ 光源集中，適合檢測小物體。
- Complied with mask tilt, mounted in narrow space.  
/ 配合專屬狹光片，可安裝窄小空間。

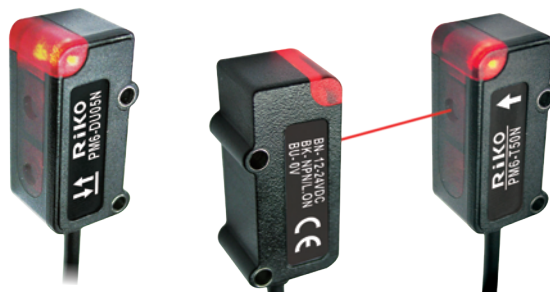

PM6

光電—光柵—超音波感測器

R5JM  
R3JK  
LK  
LRS  
PK3  
PKG3  
PK5  
PM6

PTQ18  
RMF  
MMF

SU07  
SU  
SU18  
SU30

SPR  
RX

OAP  
ASP

RU18

Model / 型號	PM6-DU05N	PM6-T50N	PM6-2NP
	PM6-DU05P	PM6-T50P	-
Sensing type / 檢出方式	Diffuse reflection / 擴散反射式	Through beam / 對照式	
Sensing distance / 檢出距離	5 cm, White paper 10x10 cm	50cm	2M
Emitting light / 發光源	Infrared LED 940nm		
Operating voltage / 工作電壓	DC12 ~24V±10% (Ripple P-P : 10% Max.)		
Current consumption / 消耗電流	20mA Max.	30mA Max.	
Load current / 負載電流	100mA Max. at DC24V		
Output type / 輸出模式	N : NPN L.on P : PNP L.on	N : NPN D.on P : PNP D.on	
Protection circuit / 保護電路	Reversed supply circuit protection, short circuit protection output 電源反接保護及輸出短路保護		
Response time / 反應頻率	1000 Hz		
Insulation resistance / 隔離阻抗	20MΩ min. (DC500V)		
Voltage withstandability / 絕緣耐壓	AC1000V 60Hz for 60 Sec.		
Operating temperature / 工作時溫度	-10°C ~ +45°C ( No freezing allowed 不可結霜,結冰 )		
Ambient humidity / 工作時溼度	35% ~ 85% RH 相對溼度		
Storage temperature / 儲存時溫度	-10°C ~ +55°C ( No freezing allowed 不可結霜,結冰 )		
Storage humidity / 儲存時溼度	35% ~ 95% RH 相對溼度		
Protection degree / 防水等級	IP64		
Material / 外觀材質	ABS		
Wiring method / 出線方式	Ø2.4 x 2M / 3-wires	(Receiver)Ø2.4 x 2 M / 3-wires (Emitter)Ø2.4 x 2 M / 2-wires	(Receiver)Ø2.4 x 2 M / 4-wires (Emitter)Ø2.4 x 2 M / 2-wires
Option / 選購配件	Bracket / 固定架：PK5/PM6 Mounting Bracket		
Weight / 重量	20g	40g	

## Dimensions / 尺寸圖 (mm)

### • PM6-DU05N/P

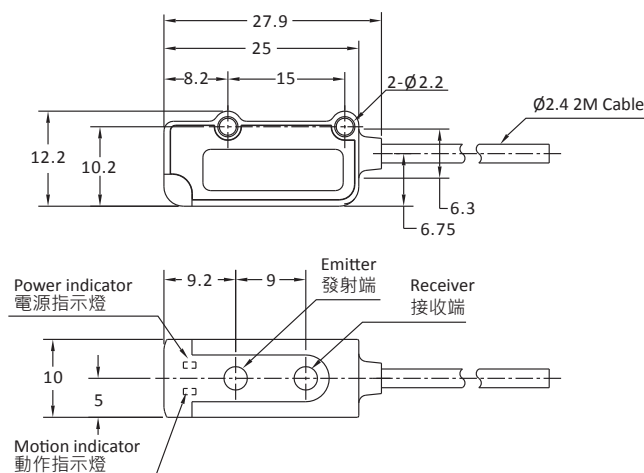

### • PM6-T50N/P • PM6-2NP

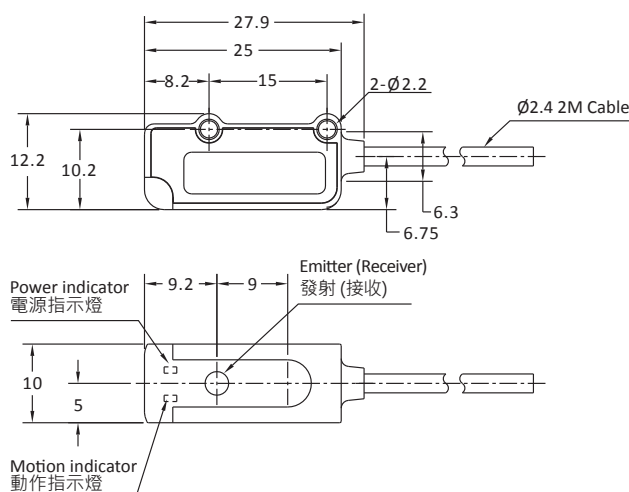

# 高防水性T型光電

# Superior Waterproof T-style Photo Sensor

## Characteristic / 特點：

- T-shaped housing design, saving space.  
/ T型設計，省空間。
- Bright Dual LED output indicators.  
/ 高亮度電源及動作指燈。
- Superior waterproof IP67. / IP67防水等級。
- Through beam type : SD=20M.  
/ 長距對照式檢距20M。
- NP model : NPN+PNP L.on/D.on 4-in-1 outputs.  
/ NP電路：NPN/PNP L.on/D.on 4-in-1輸出。



Model / 型號	NPN L.on/D.on	PTQ18-DU10/40N	PTQ18-DU10/40NK1	PTQ18-20N	PTQ18-20NK1
	PNP L.on/D.on	PTQ18-DU10/40P	PTQ18-DU10/40PK1	PTQ18-20P	PTQ18-20PK1
	NPN L.on/D.on PNP L.on/D.on	PTQ18-DU10/40NP	PTQ18-DU10/40NPK1	PTQ18-20NP	PTQ18-20NPK1
Sensing type / 檢出方式	Diffuse reflection / 擴散反射式			Through beam / 對照式	
Sensing distance / 檢出距離	10cm / 40cm White paper 10 x 10 cm / 20 x 20 cm			20M	
Emitting light / 發光源	Infrared LED 850 nm / 紅外線 LED 850 nm				
Operating voltage / 工作電壓	DC12 ~ 24 V				
Current Consumption / 消耗電流	20mA Max.			(Receiver / 接收) 20mA Max. (Emitter / 發射) 18mA Max.	
Load current / 負載電流	100mA Max. at DC24V				
Response time / 反應頻率	650 Hz			130 Hz	
Insulation resistance / 隔離阻抗	20MΩ min. (DC500V)				
Voltage withstandability / 絕緣耐壓	AC1000V 60Hz for 60 Sec.				
Operating temperature / 工作溫度	- 20 °C ~ + 60 °C (不可結霜, 結冰)				
Ambient humidity / 工作溼度	35% ~ 85% RH				
Protection degree / 防水等級	IP67				
Option / 選購配件	M124R-PVC-2M				
Material / 外觀材質	ABS				
Wiring method / 出線方式	PTQ18-□N/P/NP	Ø4.2 x 2 M / 4-wires / Ø4.2 x 2 M / 4 線		(Receiver / 接收) Ø4.2 x 2 M / 4 線 (Emitter / 發射) Ø4.2 x 2 M / 2 線	
	PTQ18-□K1	M12 plug-in connector type / M12接頭			
Weight / 重量	PTQ18-□N/P/NP	68.5g		137g	
	PTQ18-□K1	18g		36g	

PTQ18

光電—光柵—超音波感測器

R5JM  
R3JK  
LK  
LRS  
PK3  
PKG3  
PK5  
PM6

PTQ18  
RMF  
MMF

SU07  
SU  
SU18  
SU30

SPR  
RX

OAP  
ASP

RU18

## Dimensions / 尺寸圖 (mm)

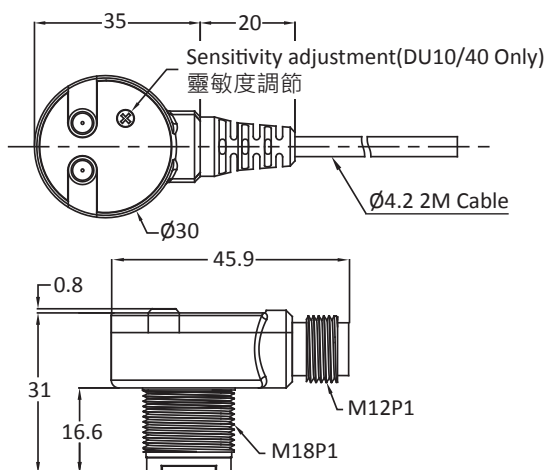

## Wiring diagrams / 接線圖

### Diffuse reflection / 擴散反射式

#### NP Output

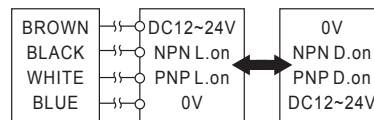

### 對照式 / 鏡片反射式

#### NP Output

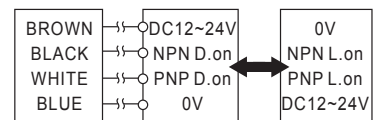

#### NPK1 Output

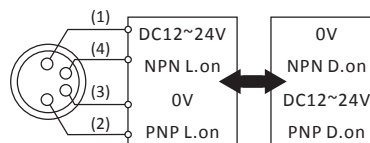

(1) BROWN (3) BLUE  
(2) WHITE (4) BLACK

#### NPK1 Output

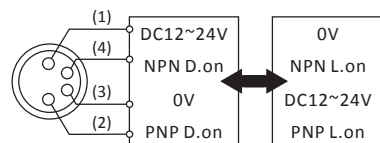

(1) BROWN (3) BLUE  
(2) WHITE (4) BLACK

# Superior Waterproof T-style Photo Sensor

# 高防水性T型光電

## Characteristic / 特點：

- Visible red light spot.  
/ 可見紅光光點，方便調整。
- Superior waterproof IP67.  
/ IP67防水等級。
- Polarized retroreflective model for bright surface target.  
/ IP67防水等級。



PTQ18

光電—光柵—超音波感測器

R5JM  
R3JK  
LK  
LRS  
PK3  
PKG3  
PK5  
PM6

PTQ18  
RMF  
MMF

SU07  
SU  
SU18  
SU30

SPR  
RX

OAP  
ASP

RU18

Model / 型號	NPN L.on/D.on	PTQ18-R2N	PTQ18-R2NK1	PTQ18-QR2N	PTQ18-QR2NK1	PTQ18-PR1N	PTQ18-PR1NK1
	PNP L.on/D.on	PTQ18-R2P	PTQ18-R2PK1	PTQ18-QR2P	PTQ18-QR2PK1	PTQ18-PR1P	PTQ18-PR1PK1
	NPN L.on/D.on PNP L.on/D.on	PTQ18-R2NP	PTQ18-R2NPK1	PTQ18-QR2NP	PTQ18-QR2NPK1	PTQ18-PR1NP	PTQ18-PR1NPK1
Sensing type / 檢出方式	Retroreflective / 鏡片反射式		Retroreflective(RED) / 鏡片反射式(紅光)		Polarizing Retroreflective / 偏光鏡片反射式		
Sensing distance / 檢出距離	2M		2M		1M		
Emitting light / 發光源	Infrared / 紅外線 LED 850 nm		Red LED 650nm				
Operating voltage / 工作電壓	DC12 ~ 24 V						
Current Consumption / 消耗電流	20mA Max.						
Load current / 負載電流	100mA Max. at DC24V						
Response time / 反應頻率	650 Hz						
Insulation resistance / 隔離阻抗	20MΩ min. (DC500V)						
Voltage withstandability / 絕緣耐壓	AC1000V 60Hz for 60 Sec.						
Operating temperature / 工作溫度	- 20 °C ~ + 60 °C (不可結霜, 結冰)						
Ambient humidity / 工作溼度	35% ~ 85% RH						
Protection degree / 防水等級	IP67						
Option / 選購配件	M124R-PVC-2M						
Material / 外觀材質	ABS						
Wiring method / 出線方式	PTQ18-□N/P/NP	Pre-wired Ø4.2 x 2M / 4-wires					
	PTQ18-□K1	M12 plug-in connector type / M12接頭					
Weight / 重量	PTQ18-□N/P/NP	68.5g					
	PTQ18-□K1	18g					

## Dimensions / 尺寸圖 (mm)

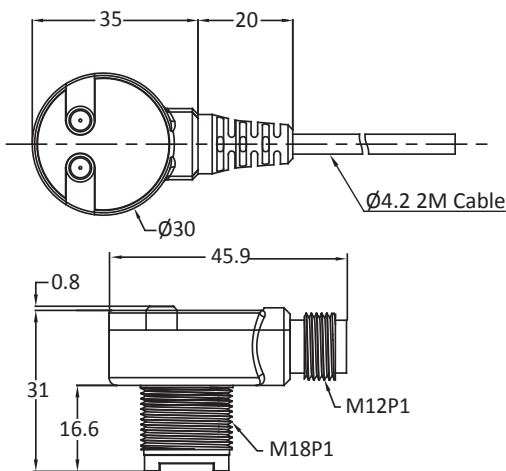

## Wiring diagrams / 接線圖

### NP Output

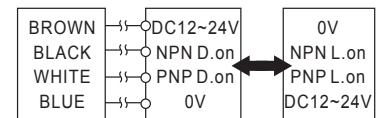

### NPK1 Output

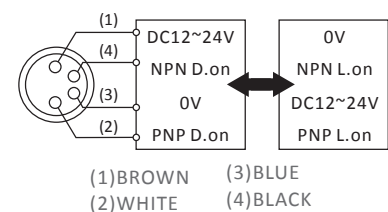

# 塑膠外殼光電

# Tubular Photo Sensor

## Characteristic / 特點：

- Standard M18 cylindrical metal tube.  
/ 國際標準規格M18螺牙。
- Threaded length=35mm.  
/ 螺牙長度35mm，易於安裝調整。
- ABS barrel applied to factory environments.  
/ ABS塑膠外殼，抗環境能力佳。



Model / 型號	RMF-DU30KP2	RMF-DU30KP2K	RMF-5KP2	RMF-5KP2K
Sensing type / 檢出方式	Diffuse reflection / 擴散反射式		Through beam / 對照式	
Sensing distance / 檢出距離	30 cm, White paper 20 x 20 cm		5M	
Emitting light / 發光源	Infrared LED 875 nm		Infrared LED 850 nm	
Operating voltage / 工作電壓	DC12 ~ 24 V			
Current Consumption / 消耗電流	30 mA Max.		45 mA Max.	
Load current / 負載電流	100mA Max. at DC24V			
Output type / 輸出模式	NPN L.on/D.on PNP D.on./L.on			
Response time / 反應頻率	650 Hz			
Insulation resistance / 隔離阻抗	20MΩ min. (DC500V)			
Voltage withstandability / 絕緣耐壓	AC1000V 60Hz for 60 Sec.			
Operating temperature / 工作溫度	- 25 °C ~ + 60 °C (不可結霜, 結冰)			
Ambient humidity / 工作溼度	35% ~ 85% RH			
Protection degree / 防水等級	IP66			
Material / 外觀材質	ABS			
Wiring method / 出線方式	Pre-wired Ø4.2 x 2M / 4-wires	M12 pigtailed type / M12出線式接頭型	(Receiver) Ø5.2x2M / 4-wires (Emitter) Ø5.2 x 2M / 2-wires	M12 pigtailed type / M12出線式接頭型
Option / 選購配件	M124R-PVC-2M Bracket / 固定架 : MF-01			
Weight / 重量	80g	40g	60g	60g

## Dimensions / 尺寸圖 (mm)

- RMF-DU30KP2
- RMF-10KP2

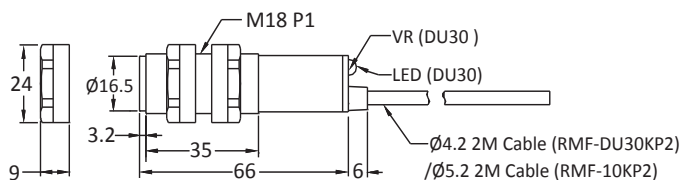

- RMF-DU30KP2K
- RMF-10KP2K

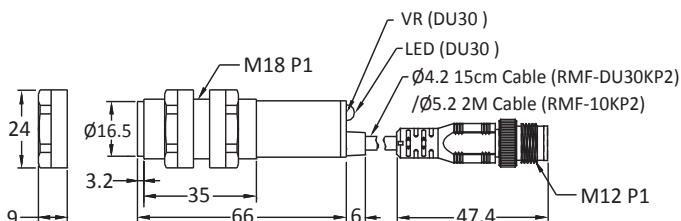

## Wiring diagrams / 接線圖

### KP2 Output or Receiver

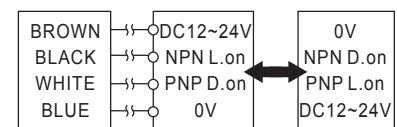

### KP2 (Emitter)

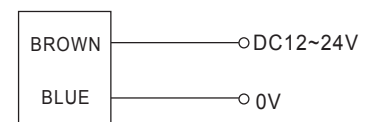

RMF

光電一光柵一超音波感測器

R5JM  
R3JK  
LK  
LRS  
PK3  
PKG3  
PK5  
PM6

PTQ18  
RMF  
MMF

SU07  
SU  
SU18  
SU30

SPR  
RX

OAP  
ASP

RU18

## Characteristic / 特點：

- Standard M18 cylindrical metal tube.  
/ 國際標準規格M18螺牙。
- Threaded length=35mm.  
/ 螺牙長度35mm，易於安裝調整。
- ABS barrel applied to factory environments.  
/ ABS塑膠外殼，抗環境能力佳。

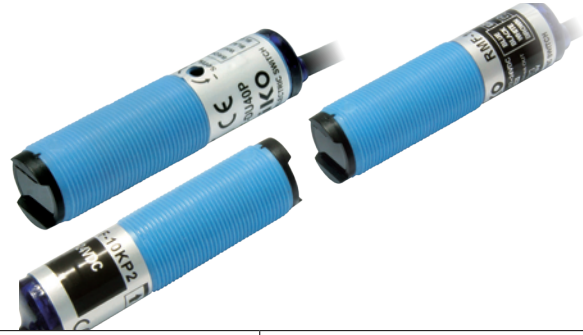

RMF

光電  
—  
光柵  
—  
超音波感測器

R5JM  
R3JK  
LK  
LRS  
PK3  
PKG3  
PK5  
PM6

PTQ18  
RMF  
MMF

SU07  
SU  
SU18  
SU30

SPR  
RX

OAP  
ASP

RU18

Model / 型號	RMF-DU10□ RMF-DU40□	RMF-10□ RMF-20□	
	RMF-DU10□K RMF-DU40□K	RMF-10□K RMF-20□K	
	RMF-DU10□K1 RMF-DU40□K1	RMF-10□K1 RMF-20□K1	
Sensing type / 檢出方式	Diffuse reflection / 擴散反射式	Through beam / 對照式	
Sensing distance / 檢出距離	10 cm , White paper 10 x 10 cm 40 cm , White paper 20 x 20 cm	10 M 20 M	
Emitting light / 發光源	Infrared LED 875 nm	Infrared LED 875 nm	
Operating voltage / 工作電壓	DC12 ~ 24 V		
Current Consumption / 消耗電流	25 mA Max.	45 mA Max.	
Load current / 負載電流	100mA Max. at DC24V		
Output type / 輸出模式	N : NPN L.on/D.on / P : PNP L.on/D.on		
Response time / 反應頻率	650 Hz		
Insulation resistance / 隔離阻抗	20MΩ min. (DC500V)		
Voltage withstandability / 絕緣耐壓	AC1000V 60Hz for 60 Sec.		
Operating temperature / 工作溫度	- 20 °C ~ + 60 °C (不可結霜, 結冰)		
Ambient humidity / 工作溼度	35% ~ 85% RH		
Protection degree / 防水等級	IP66		
Material / 外觀材質	ABS		
Wiring method / 出線方式	RMF-DU10/40□ RMF-10/ RMF-DU10/40□K RMF-10/20□K	Pre-weird Ø5.2 x 2 M / 4-wires M12 pigtailed connector type / M12 接頭15cm電線式	
	RMF-DU10/40□K1 RMF-10/20□K1	M12 plug-in connector type / M12 接頭	
		(Receiver) Ø5.2 x 2 M / 4-wires / (Emitter) Ø5.2 x 2 M / 2-wires	
Option / 選購配件	M124R-PVC-2M Bracket / 固定架 : MF-01		
Weight / 重量	RMF-DU10/40□ RMF-10/20□	85g	165g
	RMF-DU10/40□K RMF-10/20□K	35g	70g
	RMF-DU10/40□K1 RMF-10/20□K1	20g	40g

## Dimensions / 尺寸圖 (mm)

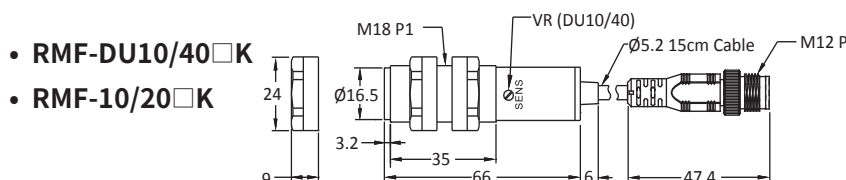
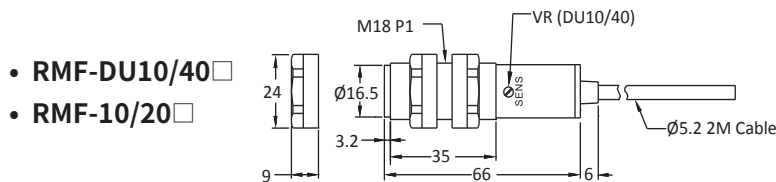

- RMF-DU10/40□K1
- RMF-10/20□K1

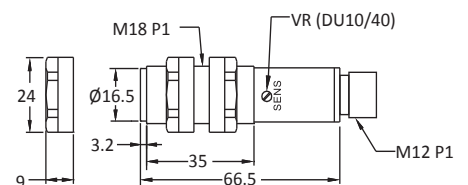

# 塑膠外殼光電

# Tubular Photo Sensor

## Characteristic / 特點：

- Standard M18 cylindrical metal tube.  
/ 國際標準規格M18螺牙。
- Threaded length=35mm.  
/ 螺牙長度35mm，易於安裝調整。
- ABS barrel applied to factory environments.  
/ ABS塑膠外殼，抗環境能力佳。



Model / 型號	RMF-CR2□	RMF-CR2□K	RMF-CR2□K1
Sensing type / 檢出方式	Retroreflective / 鏡片反射式		
Sensing distance / 檢出距離	2M		
Emitting light / 發光源	Infrared LED 940 nm		
Operating voltage / 工作電壓	DC12 ~ 24 V		
Current Consumption / 消耗電流	25 mA Max.		
Load current / 負載電流	100mA Max. at DC24V		
Output type / 輸出模式	N : NPN L.on/D.on / P : PNP L.on/D.on		
Response time / 反應頻率	650 Hz		
Insulation resistance / 隔離阻抗	20MΩ min. (DC500V)		
Voltage withstandability / 絕緣耐壓	AC1000V 60Hz for 60 Sec.		
Operating temperature / 工作溫度	- 20 °C ~ + 60 °C (不可結霜, 結冰)		
Ambient humidity / 工作溼度	35% ~ 85% RH		
Protection degree / 防水等級	IP66		
Material / 外觀材質	ABS		
Wiring method / 出線方式	Pre-weird Ø5.2 x 2 M / 4-wires	M12 pigtailed connector type / M12 接頭15cm電線式	M12 plug-in connector type / M12 接頭型
Option / 選購配件	M124R-PVC-2M Bracket / 固定架 : MF-01		
Weight / 重量	85g	35g	20g

## Dimensions / 尺寸圖 (mm)

### • RMF-CR2□

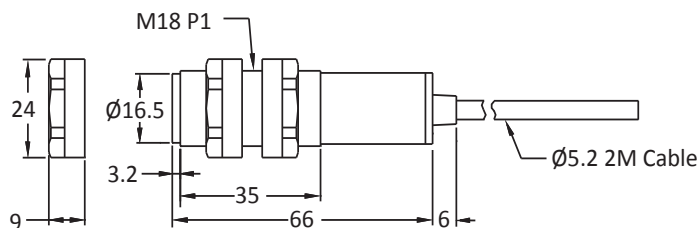

### • RMF-CR2□K

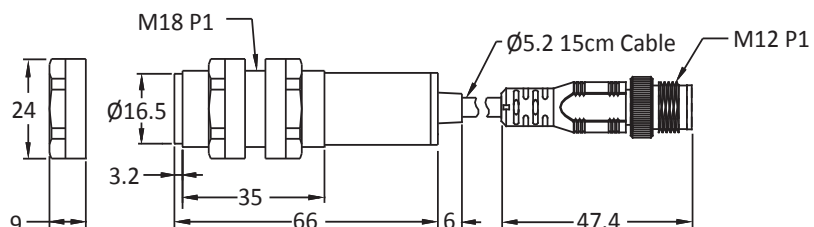

### • RMF-CR2□K1

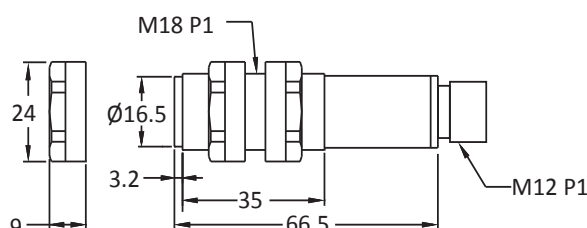

RMF

光電—光柵—超音波感測器

R5JM  
R3JK  
LK  
LRS  
PK3  
PKG3  
PK5  
PM6

PTQ18  
RMF  
MMF

SU07  
SU  
SU18  
SU30

SPR  
RX

OAP  
ASP

RU18

## Characteristic / 特點：

- Standard M18 cylindrical metal tube.  
/ 國際標準規格M18螺牙。
- Threaded length 35mm.  
/ 螺牙長度35mm，易於安裝調整。
- Solid and durable.  
/ 金屬本體，堅固耐用。



MMF

光電—光柵—超音波感測器

R5JM  
R3JK  
LK  
LRS  
PK3  
PKG3  
PK5  
PM6

PTQ18  
RMF  
MMF

SU07  
SU  
SU18  
SU30

SPR  
RX

OAP  
ASP

RU18

Model / 型號	MMF-DU10□ MMF-DU40□	MMF-10□ MMF-20□	
	MMF-DU10□K MMF-DU40□K	MMF-10□K MMF-20□K	
	MMF-DU10□K1 MMF-DU40□K1	MMF-10□K1 MMF-20□K1	
Sensing type / 檢出方式	Diffuse reflection / 擴散反射式	Through beam / 對照式	
Sensing distance / 檢出距離	10 cm , White paper 10 x 10 cm 40 cm , White paper 20 x 20 cm	10 M 20 M	
Emitting light / 發光源	Infrared LED 875 nm	Infrared LED 850 nm	
Operating voltage / 工作電壓	DC12 ~ 24 V		
Current Consumption / 消耗電流	25 mA Max.	45 mA Max.	
Load current / 負載電流	100mA Max. at DC24V		
Output type / 輸出模式	N : NPN L.on/D.on / P : PNP L.on/D.on		
Response time / 反應頻率	650 Hz		
Insulation resistance / 隔離阻抗	20MΩ min. (DC500V)		
Voltage withstandability / 絕緣耐壓	AC1000V 60Hz for 60 Sec.		
Operating temperature / 工作溫度	- 20 °C ~ + 60 °C (不可結霜，結冰)		
Ambient humidity / 工作溼度	35% ~ 85% RH		
Protection degree / 防水等級	IP66		
Material / 外觀材質	Nickel plated brass		
Wiring method / 出線方式	MMF-DU10/40□ MMF-10/20□	Pre-weird Ø5.2 x 2 M / 4-wires (Receiver) Ø5.2 x 2 M / 4-wires / (Emitter) Ø5.2 x 2 M / 2-wires	
	MMF-DU10/40□K MMF-10/20□K	M12 pigtailed connector type / M12 接頭15cm電線式	
	MMF-DU10/40□K1 MMF-10/20□K1	M12 plug-in connector type / M12 接頭	
Option / 選購配件	M124R-PVC-2M Bracket / 固定架 : MF-01		
Weight / 重量	MMF-DU10/40□ MMF-10/20□	105g	210g
	MMF-DU10/40□K MMF-10/20□K	50g	100g
	MMF-DU10/40□K1 MMF-10/20□K1	40g	80g

## Dimensions / 尺寸圖 (mm)

- MMF-DU10/40□
- MMF-10/20□

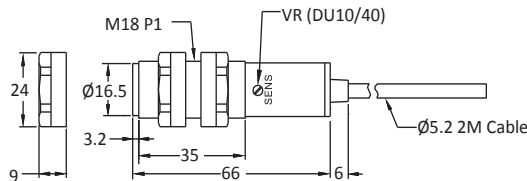

- MMF-DU10/40□K1
- MMF-10/20□K1

- MMF-DU10/40□K
- MMF-10/20□K

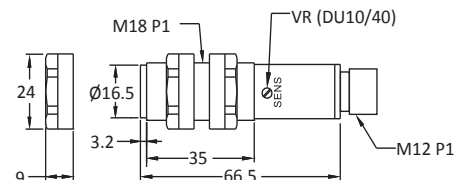
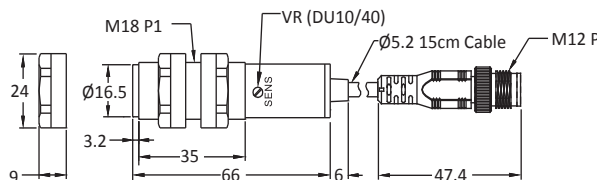

# 金屬外殼光電

# Tubular Photo Sensor

## Characteristic / 特點：

- Standard M18 cylindrical metal tube.  
/ 國際標準規格M18螺牙。
- Threaded length 35mm.  
/ 螺牙長度35mm，易於安裝調整。
- Solid and durable.  
/ 金屬本體，堅固耐用。

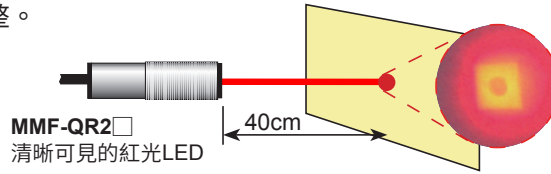

Model / 型號	MMF-CR2□	MMF-QR2□
	MMF-CR2□K	MMF-QR2□K
	MMF-CR2□K1	MMF-QR2□K1
Sensing type / 檢出方式	Retroreflective / 鏡片反射式	Retroreflective(Red LED) / 鏡片反射式(紅光)
Sensing distance / 檢出距離	2M	
Emitting light / 發光源	Infrared LED 940 nm	Red LED 650 nm
Operating voltage / 工作電壓	DC12 ~ 24 V	
Current Consumption / 消耗電流	25 mA Max.	
Load current / 負載電流	100mA Max. at DC24V	
Output type / 輸出模式	N : NPN L.on/D.on / P : PNP L.on/D.on	
Response time / 反應頻率	650 Hz	
Insulation resistance / 隔離阻抗	20MΩ min. (DC500V)	
Voltage withstandability / 絕緣耐壓	AC1000V 60Hz for 60 Sec.	
Operating temperature / 工作溫度	- 20 °C ~ + 60 °C (不可結霜，結冰)	
Ambient humidity / 工作溼度	35% ~ 85% RH	
Protection degree / 防水等級	IP66	
Material / 外觀材質	Nickel plated brass	
Wiring method / 出線方式	MMF-CR2□ MMF-QR2□	Pre-weird Ø5.2 x 2 M / 4-wires
	MMF-CR2□K MMF-QR2□K	M12 pigtailed connector type / M12 接頭電線式
	MMF-CR2□K1 MMF-QR2□K1	M12 plug-in connector type / M12 接頭型
		M124R-PVC-2M Bracket / 固定架 : MF-01
Option / 選購配件		
Weight / 重量	MMF-CR2□ MMF-QR2□	105g
	MMF-CR2□K MMF-QR2□K	50g
	MMF-CR2□K1 MMF-QR2□K1	40g

MMF

光電—光柵—超音波感測器

R5JM  
R3JK  
LK  
LRS  
PK3  
PKG3  
PK5  
PM6

PTQ18  
RMF  
MMF

SU07  
SU  
SU18  
SU30

SPR  
RX

OAP  
ASP

RU18

## Dimensions / 尺寸圖 (mm)

- MMF-CR2□
- MMF-QR2□

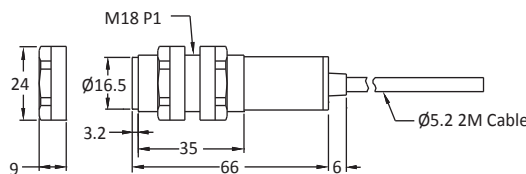

- MMF-CR2□K1
- MMF-QR2□K1

- MMF-CR2□K
- MMF-QR2□K

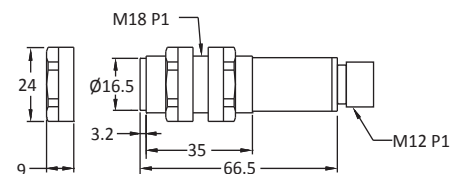
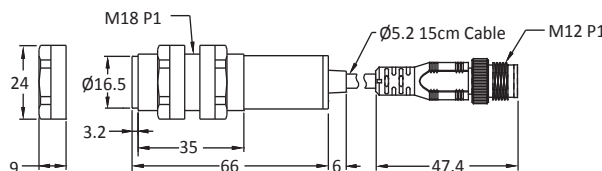

## Characteristic / 特點：

- Sensing distance 7mm.  
/ U型寬幅 7mm，檢出範圍大。
- Bright LED output indicator.  
/ 高亮度LED動作燈。
- Sensitivity adjustment 12-turn potentionmeter (VR).  
/ 多轉式(12轉)VR調整，檢出更方便。
- Visible red light detect application : Address reading and cut mark sensing.  
/ 可見紅光檢出，適合位置讀取，記號點檢知。



Model / 型號	NPN L.on/D.on PNP L.on/D.on	SU07-NP	SU07-NPB1
Sensing distance / 檢出距離		7 mm	
Min. detection object / 最小檢測物		Opaque / 非透明體 ( Ø0.7 x 10.0mm )	
Emitting light / 發光源		Red LED 660 nm	
Operating voltage / 工作電壓		DC12 ~ 24 V	
Current consumption / 消耗電流		25 mA Max.	
Load current / 負載電流		100mA Max. at DC24V	
Response time / 反應頻率		1000 Hz	
Ambient illumination / 使用環境光源		Incandescent light / 白光 : 1,000 lux max.	
Insulation resistance / 隔離阻抗		20MΩ min. (DC500V)	
Voltage withstandability / 絕緣耐壓		AC500V 60Hz for 60 Sec.	
Operating temperature / 工作溫度範圍		-10°C ~ + 55°C (不可結霜，結冰)	
Ambient humidity / 溼度範圍		35% ~ 85% RH 相對溼度	
Protection degree / 防水等級		IP64	
Vibration resistance / 耐震頻率		1.5 mm peak to peak amplitude, 10 to 55 Hz, 2 hours in X,Y and z directions 在 X、Y、Z 三軸方向，振福間隔 1.5 mm，10~55Hz 持續 2 hrs.	
Shock resistance / 耐震度		50 G repeated 10 times each in X,Y and Z directions. 在 X、Y、Z 三軸方向以 50g 力量震動 10 次	
Material / 外觀材質		PC	
Option / 選購配件		M84R-2M-PVC / M84RL-2M PVC	
Wiring method / 出線方式		Pre-wired Ø4.2 x 2 M / 4-wires	M8 connector / M8 接頭式
Weight / 重量		65g	25g

## Dimensions / 尺寸圖 (mm)

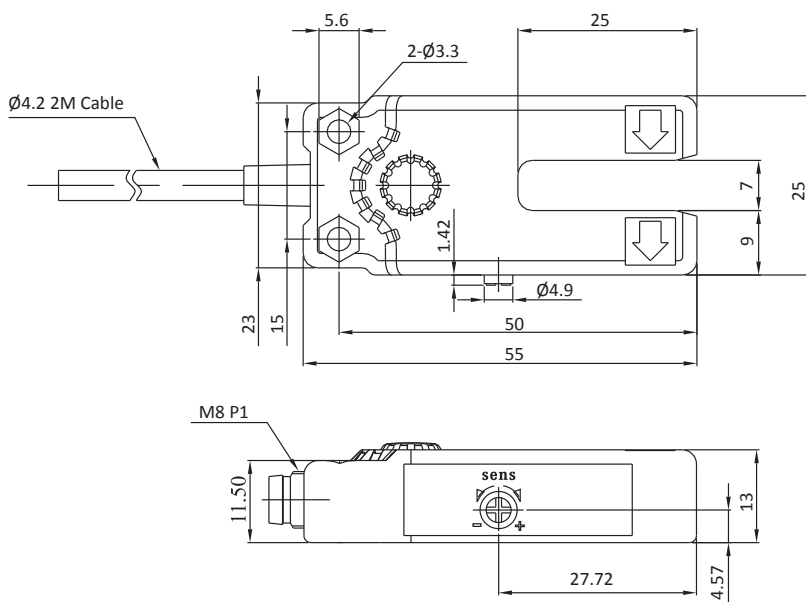

## Wiring diagrams / 接線圖

### NP Output

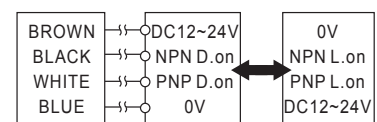



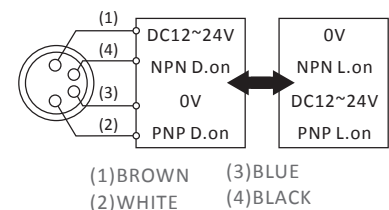

### NPB1 Output







## Timing chart / 時序圖

### NP Type

No. of optical axes/model 產品型號	Operation mode 輸出模式	Timing charts 時序表
SU07-NP SU07-NPB1	Dark ON 遮光輸出	<p>Incident light / 入光量 No incident light / 遮光量</p>  <p>Operation indicator (red) / 動作指示燈(紅色光) ON OFF</p>  <p>Control output / 控制輸出 Output transistor / 二極體 ON OFF</p>  <p>Load (e.g., relay) / 負載(例如: 繼電器) Operate / 動作 Reset / 復歸</p> 

### NP 類型

No. of optical axes/model 產品型號	Operation mode 輸出模式	Timing charts 時序表
SU07-NP SU07-NPB1	Light ON 入光輸出	<p>Incident light / 入光量 No incident light / 遮光量</p>  <p>Operation indicator (red) / 動作指示燈(紅色光) ON OFF</p>  <p>Control output / 控制輸出 Output transistor / 二極體 ON OFF</p>  <p>Load (e.g., relay) / 負載(例如: 繼電器) Operate / 動作 Reset / 復歸</p> 

SU07

光電 / 光柵 / 超音波感測器

R5JM  
R3JK  
LK  
LRS  
PK3  
PKG3  
PK5  
PM6

PTQ18  
RMF  
MMF

SU07  
SU  
SU18  
SU30

SPR  
RX

OAP  
ASP

RU18

# U-shape Photo Sensor

# U型光電

## Characteristic / 特點：

- High-speed response, 1kHz (DC-light type).  
/ 體積小，反應速度快約1kHz。
- Sensing distance 10mm, suitable for the detection of small objects.  
/ 檢測距離 10mm，適用於小物體檢測。
- Infrared beam axis 1mm width.  
/ 紅外線光軸檢測寬度 1.0mm。



SU

光電—光柵—超音波感測器

R5JM  
R3JK  
LK  
LRS  
PK3  
PKG3  
PK5  
PM6

PTQ18  
RMF  
MMF

SU07  
SU  
SU18  
SU30

SPR  
RX

OAP  
ASP

RU18

Model / 型號	SU-KP2	SU-KP2B
Sensing distance / 檢出距離	10mm	
Min. detection object / 最小檢測物	Opaque / 非透明體 (Ø0.7 x 10.0mm)	
Emitting light / 發光源	Infrared LED 940nm	
Operating voltage / 工作電壓	DC12 ~ 24 V	
Current Consumption / 消耗電流	28 mA Max.	
Load current / 負載電流	100mA Max. at DC24V	
Output type / 輸出模式	NPN D.on PNP L.on	
Response time / 反應頻率	1000 Hz	
Ambient illumination / 使用環境光源	Incandescent light / 白光 : 1,000 lux max.	
Insulation resistance / 隔離阻抗	20MΩ min. (DC500V)	
Voltage withstandability / 絕緣耐壓	AC500V 60Hz for 60 Sec.	
Operating temperature / 工作溫度範圍	-10°C ~ + 55°C (不可結霜, 結冰)	
Ambient humidity / 溼度範圍	45% ~ 85% RH 相對溼度	
Protection degree / 防水等級	IP64	
Vibration resistance / 耐震頻率	1.5-mm peak-to-peak amplitude, 10 to 55 Hz, 2 hours each in X, Y, and Z directions 在 X、Y、Z 三軸方向，振幅間隔 1.5 mm，10~55Hz 持續 2 hrs.	
Shock resistance / 耐震度	50G, repeated 10 times each in X, Y, and Z directions 在 X、Y、Z 三軸方向以 50g 力量震動 10 次	
Material / 外觀材質	PC	
Option / 選購配件	M84R-2M-PVC / M84RL-2M PVC	
Wiring method / 出線方式	Pre-wired Ø4.2 x 2 M / 3-wires	M8 pigtailed type / M8 出線式接頭型
Weight / 重量	55g	35g

## Dimensions / 尺寸圖 (mm)

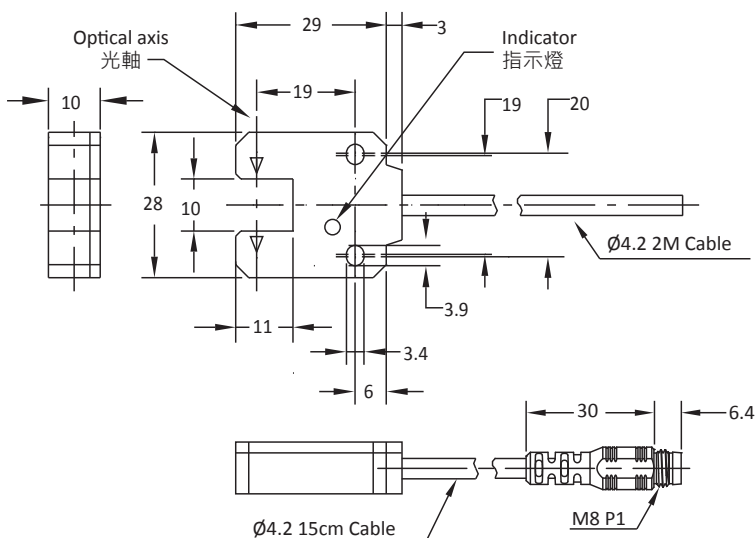

## Wiring diagrams / 接線圖

### KP2 Output

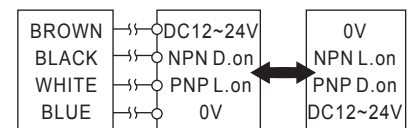

# U型光電

# U-shape Photo Sensor

SU18

光電 / 光柵 / 超音波感測器

R5JM  
R3JK  
LK  
LRS  
PK3  
PKG3  
PK5  
PM6

PTQ18  
RMF  
MMF

SU07  
SU  
SU18  
SU30

SPR  
RX

OAP  
ASP

RU18

## Characteristic / 特點：

- Compact and durable.  
/ 金屬外殼，堅固耐用。
- Wide vane, 18 mm (DC-light type).  
/ 檢測距離18 mm，適用於小物體檢測。
- SU18 has a better prevention of outside light.  
/ SU18 對外亂光干擾抵抗優。



Model / 型號	NPN D.on / L.on	SU18-N3
	PNP D.on / L.on	SU18-P3
Sensing distance / 檢出距離	18mm ±10%	
Min. detection object / 最小檢測物	Opaque / 非透明體 (Ø1.0 x 10.0mm)	
Emitting light / 發光源	Infrared LED 940 nm	
Operating voltage / 工作電壓	DC10 ~ 30 V	
Current consumption / 消耗電流	30 mA Max.	
Load current / 負載電流	100mA Max. at DC24V	
Output type / 輸出模式	NPN L.on / D.on	
Response time / 反應頻率	1000 Hz	
Ambient illumination / 使用環境光源	Incandescent light / 白熾燈 : 5,000 lux max.	
Insulation resistance / 隔離阻抗	20MΩ min. (DC500V)	
Voltage withstandability / 絕緣耐壓	AC1000V 60Hz for 60 Sec.	
Operating temperature / 工作溫度範圍	-10°C ~ + 55°C (不可結霜，結冰)	
Ambient humidity / 溼度範圍	45% ~ 85% RH 相對溼度	
Protection degree / 防水等級	IP65	
Material / 外觀材質	鋅合金鍍鎳	
Wiring method / 出線方式	Pre-wired Ø4.2 x 2 M / 3-wires	
Weight / 重量	70g	

## Dimensions / 尺寸圖 (mm)

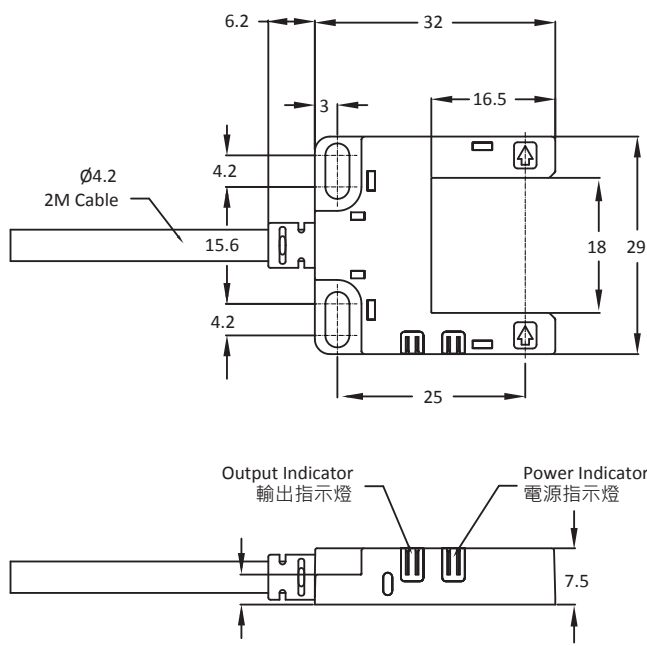

## Wiring diagrams / 接線圖

### N3 Output

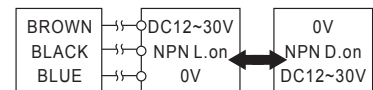

### P3 Output

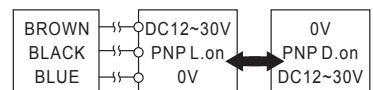

# U-shape Photo Sensor

# U型光電

## Characteristic / 特點：

- Wide sensing range : 30mm.  
/ U型寬幅 30mm，檢出範圍大。
- Two indicators (power/sensing). Easy to recognize.  
/ 雙指示燈 (電源指示 / 感應指示) 容易辨認。

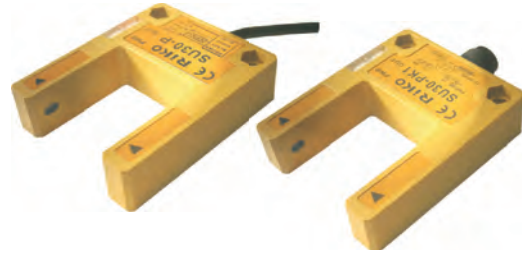

SU30

光電 / 光柵 / 超音波感測器

R5JM  
R3JK  
LK  
LRS  
PK3  
PKG3  
PK5  
PM6

PTQ18  
RMF  
MMF

SU07  
SU  
SU18  
SU30

SPR  
RX

OAP  
ASP

RU18

Model / 型號	NPN L.on / D.on PNP L.on / D.on	SU30-KP2	SU30-KP2K
Sensing distance / 檢出距離		30 mm	
Min. detection object / 最小檢測物		Opaque / 非透明體 (Ø1.0 x 10.0mm)	
Emitting light / 發光源		Infrared LED 940 nm	
Operating voltage / 工作電壓		DC12 ~ 24 V	
Current consumption / 消耗電流		20 mA Max.	
Load current / 負載電流		100mA Max. at DC24V	
Response time / 反應頻率		1000 Hz	
Ambient illumination / 使用環境光源		Incandescent light / 白光 : 3,000 lux max.	
Insulation resistance / 隔離阻抗		20MΩ min. (DC500V)	
Voltage withstandability / 絕緣耐壓		AC500V 60Hz for 60 Sec.	
Operating temperature / 工作溫度範圍		-20°C ~ + 60°C (不可結霜, 結冰)	
Ambient humidity / 溼度範圍		35% ~ 85% RH 相對溼度	
Protection degree / 防水等級		IP64	
Vibration resistance / 耐震頻率		1.5 mm peak to peak amplitude, 10 to 55 Hz, 2 hours in X,Y and z directions 在 X、Y、Z 三軸方向，振幅間隔 1.5 mm，10~55Hz 持續 2 hrs.	
Shock resistance / 耐震度		50 G repeated 10 times each in X,Y and Z directions 在 X、Y、Z 三軸方向以 50g 力量震動 10 次	
Material / 外觀材質		PC	
Option / 選購配件		M12R-PVC-2M	
Wiring method / 出線方式		Pre-wired Ø4.2 x 2 M / 4-wires	M12 Plug-in connector type / M12 出線式接頭型
Weight / 重量		86g	26g

## Dimensions / 尺寸圖 (mm)

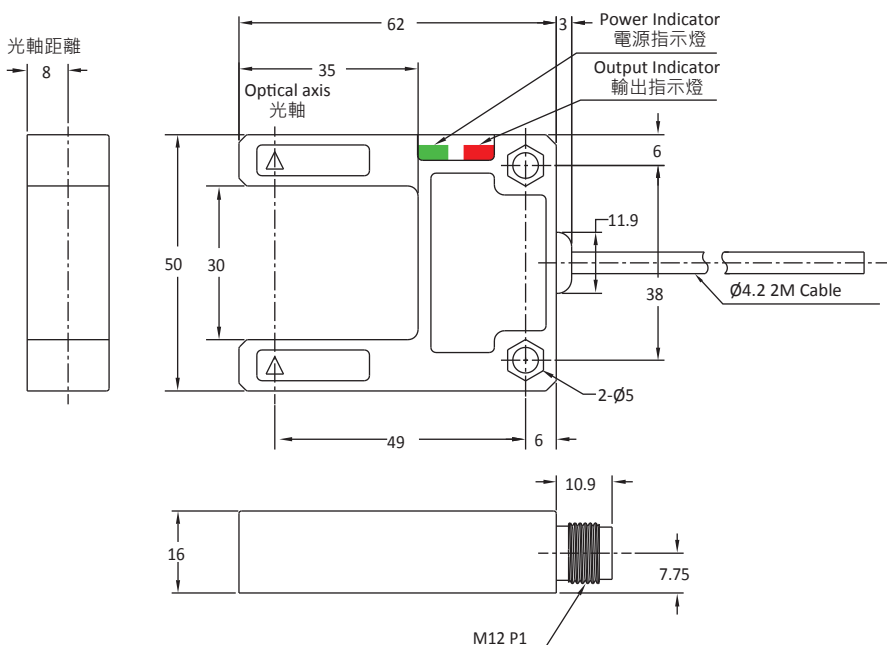

## Wiring diagrams / 接線圖

### KP2 Output

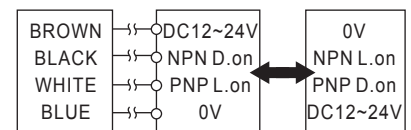

# U型光電

# U-shape Photo Sensor

SU30

光電 / 光柵 / 超音波感測器

R5JM  
R3JK  
LK  
LRS  
PK3  
PKG3  
PK5  
PM6

PTQ18  
RMF  
MMF

SU07  
SU  
SU18  
SU30

SPR  
RX

OAP  
ASP

RU18

## Characteristic / 特點：

- Two indicators (OUT1 Indicator/OUT2 Indicator) Easy to recognize.  
/ 雙指示燈 (輸出1指示燈/輸出2指示燈) 容易辨認。
- The distance is 7mm between front edge and first optic axis.  
The distance is 15mm between two optic axes.  
/ 第一光軸與前端相距 7mm，兩光軸相距 15mm。
- Two optic axes react respectively.  
/ 兩光軸各自獨立感應。



Model / 型號	NPN D.on	SU30-2N	SU30-2NK1
	PNP D.on	SU30-2P	SU30-2PK1
Sensing distance / 檢出距離	30 mm		
Min. detection object / 最小檢測物	Opaque / 非透明體 (Ø1.0 x 10.0mm)		
Emitting light / 發光源	Infrared LED 940 nm		
Operating voltage / 工作電壓	DC12 ~ 24 V		
Current consumption / 消耗電流	30 mA Max.		
Load current / 負載電流	100mA Max. at DC24V		
Response time / 反應頻率	1000 Hz		
Ambient illumination / 使用環境光源	Incandescent light / 白光 : 1,000 lux max.		
Insulation resistance / 隔離阻抗	20MΩ min. (DC500V)		
Voltage withstandability / 絕緣耐壓	AC500V 60Hz for 60 Sec.		
Operating temperature / 工作溫度範圍	-20°C ~ +60°C (不可結霜, 結冰)		
Ambient humidity / 溼度範圍	35% ~ 85% RH 相對溼度		
Protection degree / 防水等級	IP64		
Vibration resistance / 耐震頻率	1.5 mm peak to peak amplitude, 10 to 55 Hz, 2 hours in X,Y and z directions 在 X、Y、Z 三軸方向，振幅間隔 1.5 mm，10~55Hz 持續 2 hrs.		
Shock resistance / 耐震度	50 G repeated 10 times each in X,Y and Z directions 在 X、Y、Z 三軸方向以 50g 力量震動 10 次		
Material / 外觀材質	PC		
Option / 選購配件	M12R-PVC-2M		
Wiring method / 出線方式	Pre-wired Ø4.2 x 2 M / 4-wires	M12 Plug-in connector type	
Weight / 重量	86g	26g	

## Dimensions / 尺寸圖 (mm)

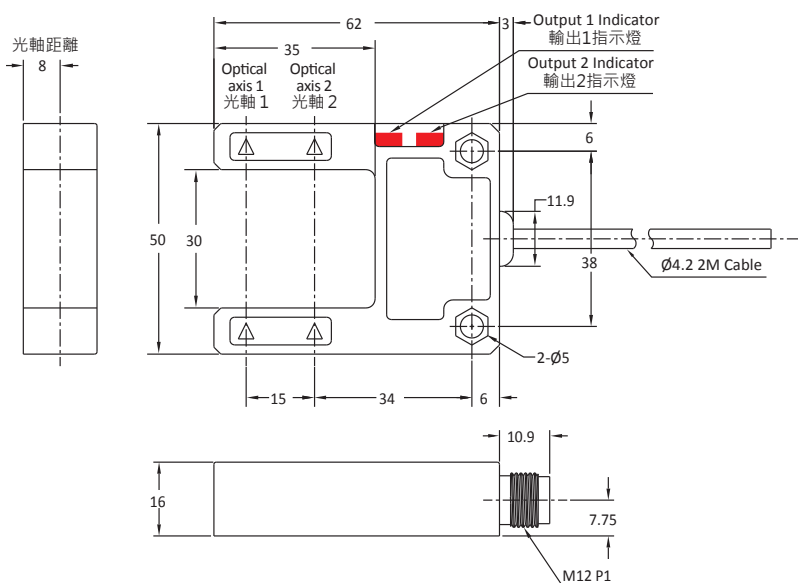

## Wiring diagrams / 接線圖

### 2N Output

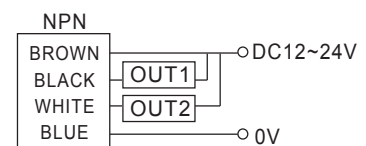

### 2P Output

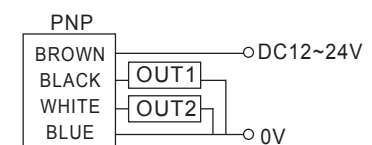

### 2 □ K1 Output

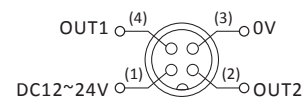

(1) BROWN (3) BLUE  
(2) WHITE (4) BLACK

## Timing chart / 時序圖

NPN/ PNP/ NP 類型

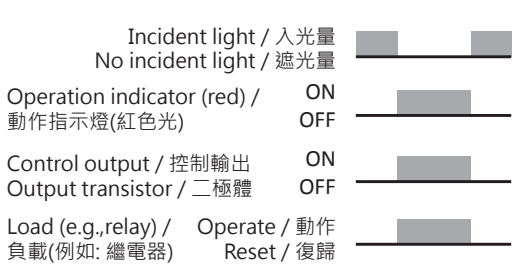
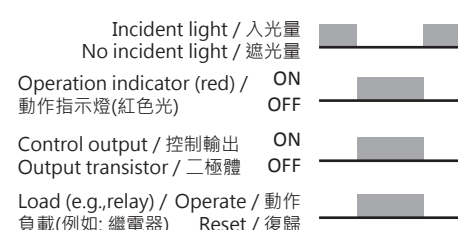
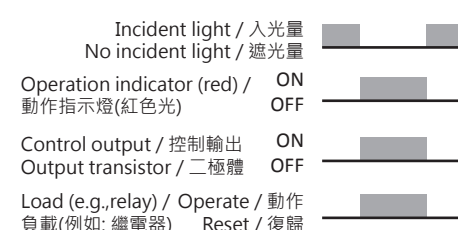
No. of optical axes/model 產品型號	Operation mode 輸出模式	Timing charts 時序表	
1 光軸 SU30-KP2 SU30-KP2K	Dark ON 遮光輸出	<p>Incident light / 入光量 </p>	
2 光軸 SU30-2N SU30-2NK1 SU30-2P SU30-2PK1	Dark ON 遮光輸出	Optical axis1 / 光軸 1	Optical axis2 / 光軸 2
		<p>Incident light / 入光量 </p> <p>Between brown and black (white) leads./ 棕色線和黑色(白色)線之間</p>	<p>Incident light / 入光量 </p> <p>Between brown and black (white) leads./ 棕色線和黑色(白色)線之間</p>

· To detect the retardation and stop locations on stacker cranes and guided trolleys.  
在堆疊棧板機械及滑軌搬運機械中，偵測減速和停止位置

### 1. One optic axis / 光軸 :

For retardation and stopping, you have to use two sensors.  
為了促成減速和停止功能，使用者需要使用 2 個擋板。

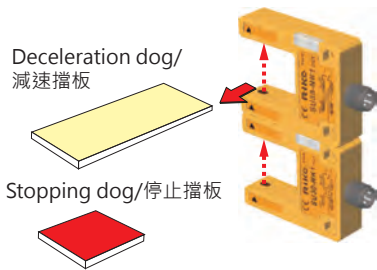

### 2. Two optic axes / 光軸 :

Just need to use one sensor if you change the shape of dock like A. It will have the same application like (1). / 只要將擋板製造成如 A 所示形狀，即可使用一個感測器實現如 (1) 同樣的功能。

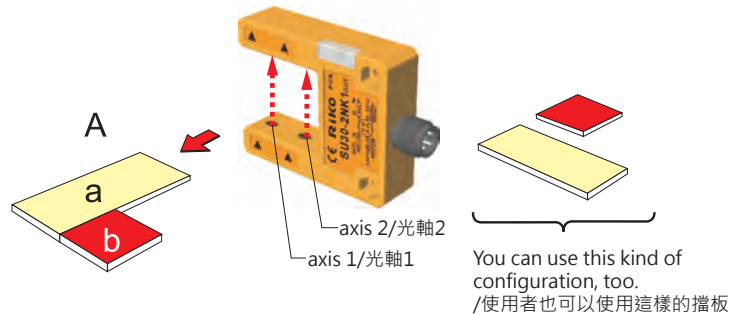

· Two optic axes sensors can be mounted side by side to read the positions.  
(A application of 8 optic axes) / 可以並排使用兩光軸感測器，去偵測位置 (8 光軸並列應用例)

The first optic axis detects the retardation on a. / 第 1 光軸檢測出擋板 a 後減速

The second optic axis detects the stopping on b. / 第 2 光軸檢測出擋板 b 後停止

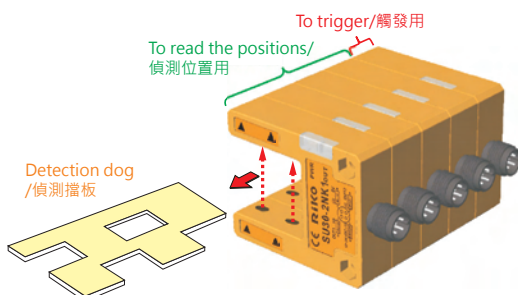

## Characteristic / 特點 :

- Front surface / Top surface sensing models available.  
/ 多種檢測方式: 上方感應、前方感應。
- Sensing distance up to 20mm.  
/ 長距檢測距離 20mm。
- Light ON/Dark ON selectable.  
/ 入光動作 / 遮光動作可選擇。

▶ 10x10cm 黑紙(無光澤)

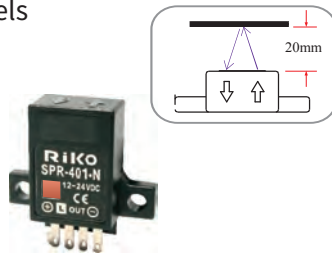

▶ 10x10cm 黑紙(無光澤)

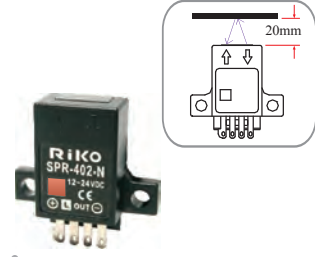

Model / 型號	SPR-401-N	SPR-401-P	SPR-402-N	SPR-402-P
Sensing type / 檢出方式	Diffuse Reflection / 擴散反射式			
Sensing distance / 檢出距離	20mm 10x10cm Black non-glossy paper / 黑紙 10x10cm			
Emitting light / 發光源	Infrared LED 940 nm			
Operating voltage / 工作電壓	DC12 ~ 24 V			
Current consumption / 消耗電流	25 mA Max.			
Load current / 負載電流	100mA Max. at DC24V			
Output type / 輸出模式	NPN L.on/D.on	PNP L.on/D.on	NPN L.on/D.on	PNP L.on/D.on
Response time / 反應頻率	1000 Hz			
Ambient illumination / 使用環境光源	受光面照度 : 6,000 lux max.			
Insulation resistance / 隔離阻抗	20MΩ min. (DC500V)			
Voltage withstandability / 絕緣耐壓	AC1000V 60Hz for 60 Sec.			
Operating temperature / 工作溫度	- 20 °C ~ + 45 °C (No freezing allowed 不可結霜, 結冰)			
Ambient humidity / 工作溼度	35% ~ 85% RH			
Material / 外觀材質	PC			
Protection degree / 防水等級	IP64			
Option / 選購配件	EE-1001 / RE-1103-PVC-1M (1M/2M/3M/5M)			
Weight / 重量	3g			

## Dimensions / 尺寸圖 (mm)

### • SPR-401-N/P

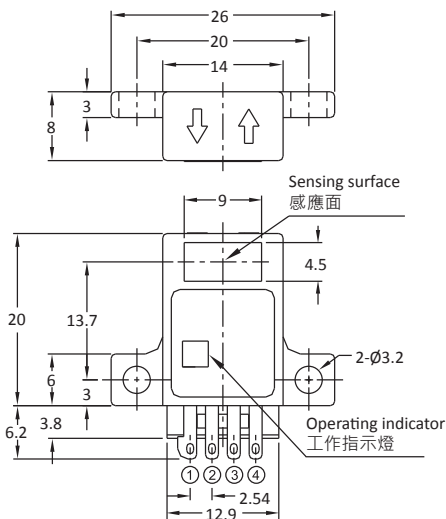

### • SPR-402-N/P

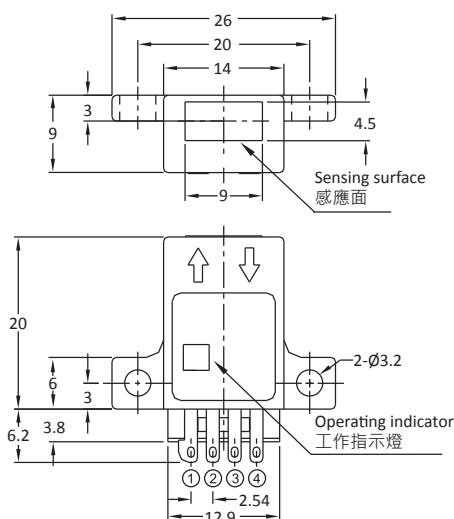

## Wiring diagrams / 接線圖

### NPN Output

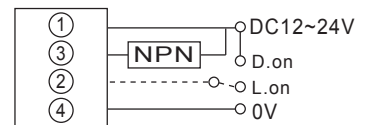
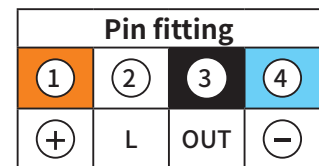

### PNP Output

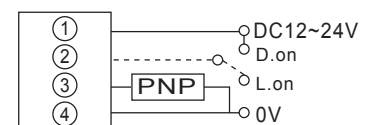
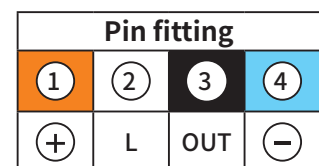

## Characteristic / 特點：

- High-speed response: 2kHz.  
/ 體積小，反應速度快約 2kHz。
- Sensing distance 6mm, suitable for the detection of small objects.  
/ 檢測距離 6mm，適用於小物體檢測。
- Complied with mask tilt, mounted in narrow space.  
/ 紅外線光軸檢測寬度 0.8x2mm。

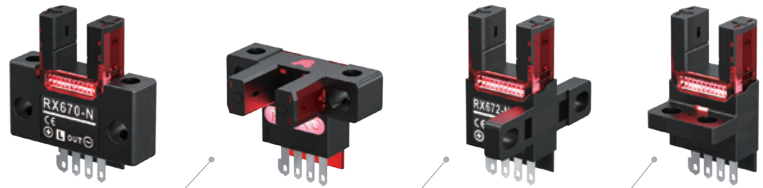

Model / 型號	RX670-N	RX671-N	RX672-N	RX673-N
	RX670-P	RX671-P	RX672-P	RX673-P
Sensing distance / 檢出距離	6 mm			
Standard sensing distance / 標準檢測物	0.8 mm			
Output type / 輸出模式	NPN L.on/D.on	NPN L.on/D.on	NPN L.on/D.on	NPN L.on/D.on
	PNP L.on/D.on	PNP L.on/D.on	PNP L.on/D.on	PNP L.on/D.on
Emitting light / 發光源	Infrared LED 940 nm			
Operating voltage / 工作電壓	DC12 ~ 30 V			
Current consumption / 消耗電流	15 mA Max.			
Load current / 負載電流	100mA Max. at DC24V			
Response time / 反應頻率	2000 Hz			
Ambient illumination / 使用環境光源	受光面照度、螢光燈：1,000 lux以下			
Insulation resistance / 隔離阻抗	20MΩ min. (DC500V)			
Voltage withstandability / 絕緣耐壓	AC1000V 60Hz for 60 Sec.			
Operating temperature / 工作溫度	0 °C ~ + 60 °C (No freezing allowed 不可結霜,結冰)			
Ambient humidity / 工作溼度	35% ~ 85% RH			
Material / 外觀材質	ABS			
Protection degree / 防水等級	IP64			
Option / 選購配件	EE-1001 / RE-1103-PVC-1M (1M/2M/3M/5M)			
Weight / 重量	3.5g	3.5g	3g	3g

## Dimensions / 尺寸圖 (mm)

### • RX-670-N/P

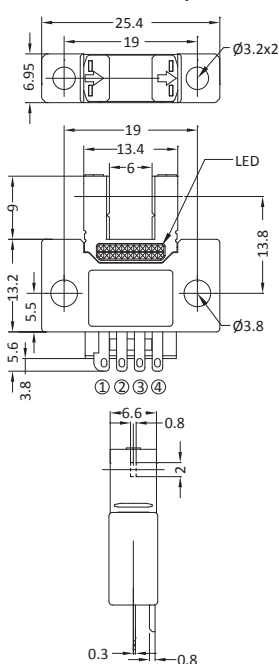

### • RX-671-N/P

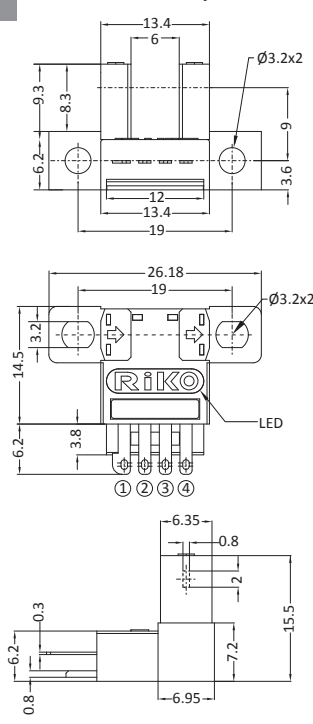

### • RX-672-N/P

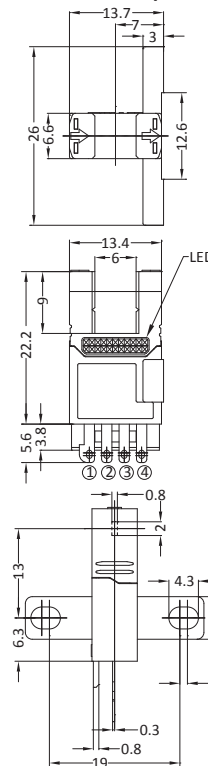

### • RX-673-N/P

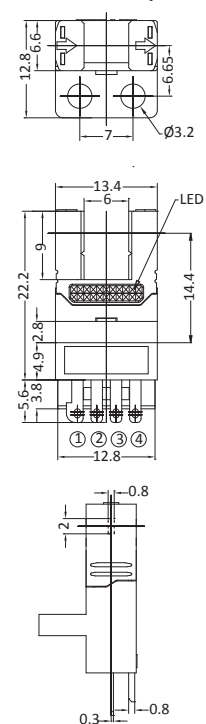

## Wiring diagrams / 接線圖

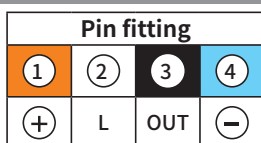

### NPN Output

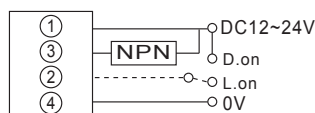

### PNP Output

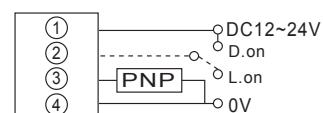

## Characteristic / 特點：

- High-speed response: 2kHz.  
/ 體積小，反應速度快約 2kHz。
- Sensing distance 6mm, suitable for the detection of small objects.  
/ 檢測距離 6mm，適用於小物體檢測。
- Complied with mask tilt, mounted in narrow space.  
/ 紅外線光軸檢測寬度 0.8x2mm。

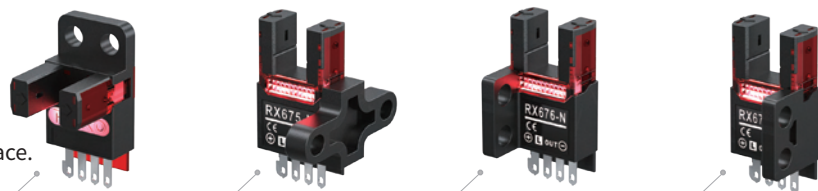

Model / 型號	RX674-N	RX675-N	RX676-N	RX677-N
	RX674-P	RX675-P	RX676-P	RX677-P
Sensing distance / 檢出距離	6 mm			
Standard sensing distance / 標準檢測物	0.8 mm			
Output type / 輸出模式	NPN L.on/D.on	NPN L.on/D.on	NPN L.on/D.on	NPN L.on/D.on
	PNP L.on/D.on	PNP L.on/D.on	PNP L.on/D.on	PNP L.on/D.on
Emitting light / 發光源	Infrared LED 940 nm			
Operating voltage / 工作電壓	DC12 ~ 30 V			
Current consumption / 消耗電流	15 mA Max.			
Load current / 負載電流	100mA Max. at DC24V			
Response time / 反應頻率	2000 Hz			
Ambient illumination / 使用環境光源	受光面照度、螢光燈：1,000 lux以下			
Insulation resistance / 隔離阻抗	20MΩ min. (DC500V)			
Voltage withstandability / 絕緣耐壓	AC1000V 60Hz for 60 Sec.			
Operating temperature / 工作溫度	0 °C ~ + 60 °C (No freezing allowed不可結霜,結冰)			
Ambient humidity / 工作溼度	35% ~ 85% RH			
Material / 外觀材質	ABS			
Protection degree / 防水等級	IP64			
Option / 選購配件	EE-1001 / RE-1103-PVC-1M (1M/2M/3M/5M)			
Weight / 重量	3.5g	3g	3g	3g

RX

光電 / 光柵 / 超音波感測器

R5JM  
R3JK  
LK  
LRS  
PK3  
PKG3  
PK5  
PM6

PTQ18  
RMF  
MMF

SU07  
SU  
SU18  
SU30

SPR  
RX

OAP  
ASP

RU18

## Dimensions / 尺寸圖 (mm)

### • RX-674-N/P

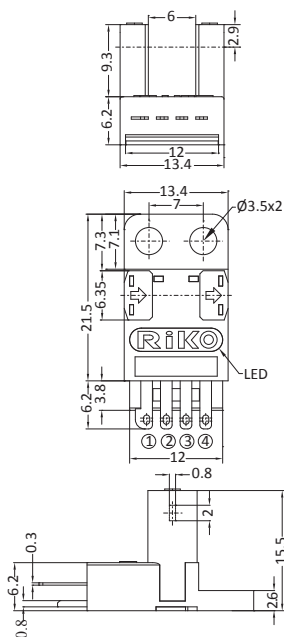

### • RX-675-N/P

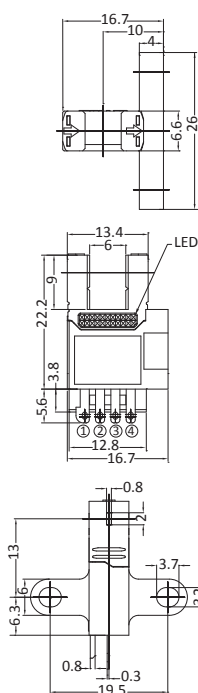

### • RX-676-N/P

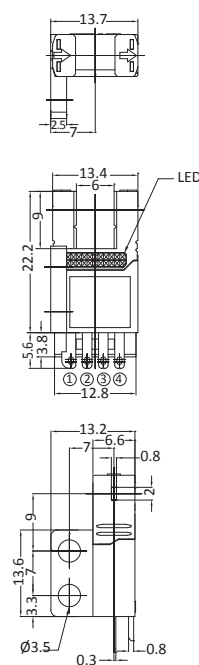

### • RX-677-N/P

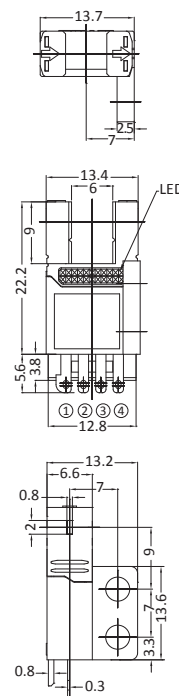

## Wiring diagrams / 接線圖

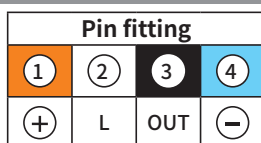

### NPN Output

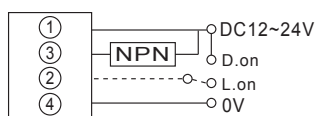

### PNP Output

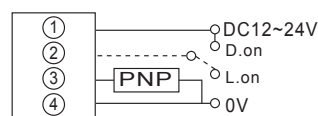

## Characteristic / 特點：

- High-speed response: 2kHz.  
/ 體積小，反應速度快約2kHz。
- Sensing distance 6mm, suitable for the detection of small objects.  
/ 檢測距離6mm，適用於小物體檢測。
- Complied with mask tilt, mounted in narrow space.  
/ 紅外線光軸檢測寬度0.8x2mm。

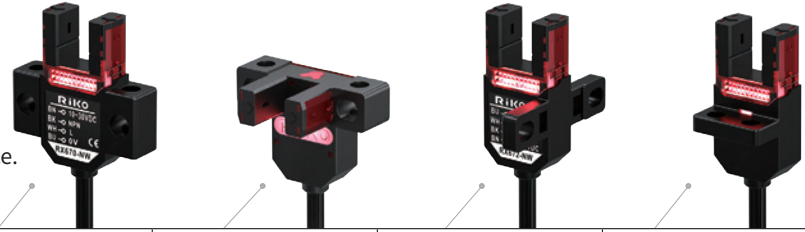

Model / 型號	RX670-NW	RX671-NW	RX672-NW	RX673-NW
	RX670-PW	RX671-PW	RX672-PW	RX673-PW
Sensing distance / 檢出距離	6 mm			
Standard sensing distance / 標準檢測物	0.8 mm			
Output type / 輸出模式	NPN L.on/D.on	NPN L.on/D.on	NPN L.on/D.on	NPN L.on/D.on
	PNP L.on/D.on	PNP L.on/D.on	PNP L.on/D.on	PNP L.on/D.on
Emitting light / 發光源	Infrared LED 940 nm			
Operating voltage / 工作電壓	DC12 ~ 30 V			
Current consumption / 消耗電流	15 mA Max.			
Load current / 負載電流	100mA Max. at DC24V			
Response time / 反應頻率	2000 Hz			
Ambient illumination / 使用環境光源	受光面照度、螢光燈：1,000 lux以下			
Insulation resistance / 隔離阻抗	20MΩ min. (DC500V)			
Voltage withstandability / 絕緣耐壓	AC1000V 60Hz for 60 Sec.			
Operating temperature / 工作溫度	0 °C ~ + 60 °C (No freezing allowed不可結霜,結冰)			
Ambient humidity / 工作溼度	35% ~ 85% RH			
Material / 外觀材質	ABS			
Protection degree / 防水等級	IP64			
Weight / 重量	28.5g	28.5g	28 g	28g

RX

光電 / 光柵 / 超音波感測器

R5JM  
R3JK  
LK  
LRS  
PK3  
PKG3  
PK5  
PM6

PTQ18  
RMF  
MMF

SU07  
SU  
SU18  
SU30

SPR  
RX

OAP  
ASP

RU18

## Dimensions / 尺寸圖 (mm)

### • RX-670-NW/PW

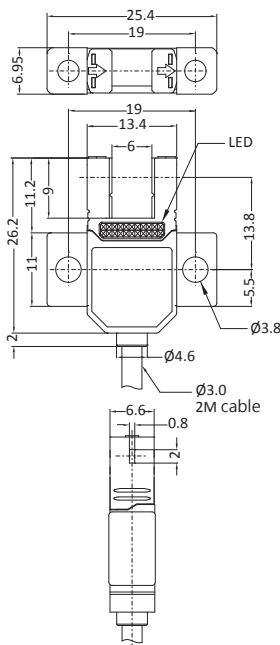

### • RX-671-NW/PW

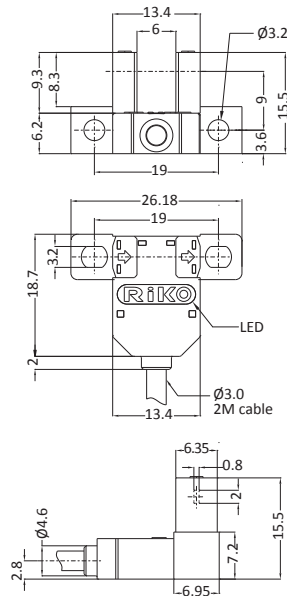

### • RX-672-NW/PW

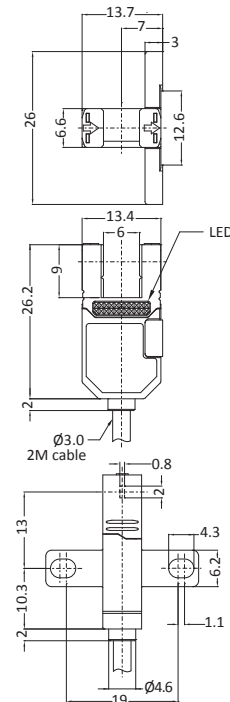

### • RX-673-NW/PW

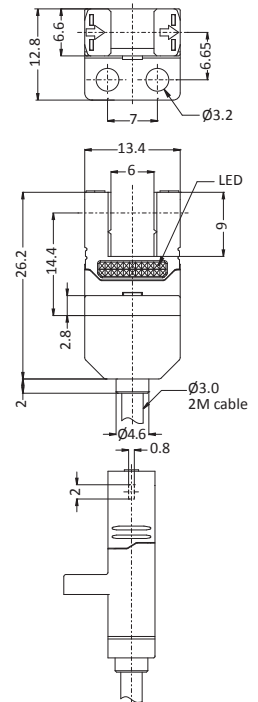

## Wiring diagrams / 接線圖

### NPN Output

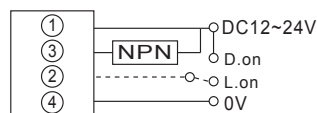

### PNP Output

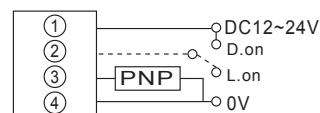

## Characteristic / 特點：

- High-speed response: 2kHz.  
/ 體積小，反應速度快約 2kHz。
- Sensing distance 6mm, suitable for the detection of small objects.  
/ 檢測距離 6mm，適用於小物體檢測。
- Complied with mask tilt, mounted in narrow space.  
/ 紅外線光軸檢測寬度 0.8x2mm。

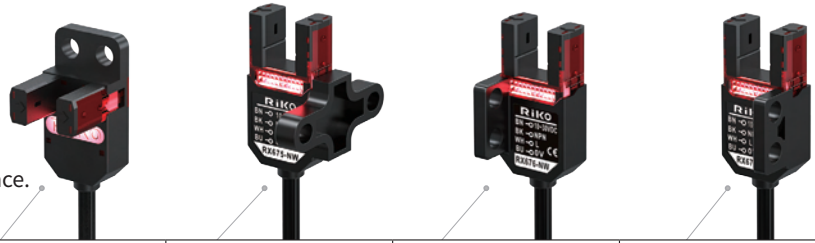

Model / 型號	RX674-NW	RX675-NW	RX676-NW	RX677-NW
	RX674-PW	RX675-PW	RX676-PW	RX677-PW
Sensing distance / 檢出距離	6 mm			
Standard sensing distance / 標準檢測物	0.8 mm			
Output type / 輸出模式	NPN L.on/D.on	NPN L.on/D.on	NPN L.on/D.on	NPN L.on/D.on
	PNP L.on/D.on	PNP L.on/D.on	PNP L.on/D.on	PNP L.on/D.on
Emitting light / 發光源	Infrared LED 940 nm			
Operating voltage / 工作電壓	DC12 ~ 30 V			
Current consumption / 消耗電流	15 mA Max.			
Load current / 負載電流	100mA Max. at DC24V			
Response time / 反應頻率	2000 Hz			
Ambient illumination / 使用環境光源	受光面照度、螢光燈：1,000 lux以下			
Insulation resistance / 隔離阻抗	20MΩ min. (DC500V)			
Voltage withstandability / 絕緣耐壓	AC1000V 60Hz for 60 Sec.			
Operating temperature / 工作溫度	0 °C ~ + 60 °C (No freezing allowed 不可結霜, 結冰)			
Ambient humidity / 工作溼度	35% ~ 85% RH			
Material / 外觀材質	ABS			
Protection degree / 防水等級	IP64			
Weight / 重量	28.5g	28g	28g	28g

## Dimensions / 尺寸圖 (mm)

### • RX-674-NW/PW

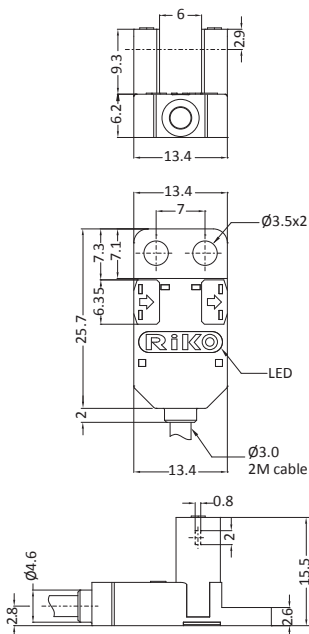

### • RX-675-NW/PW

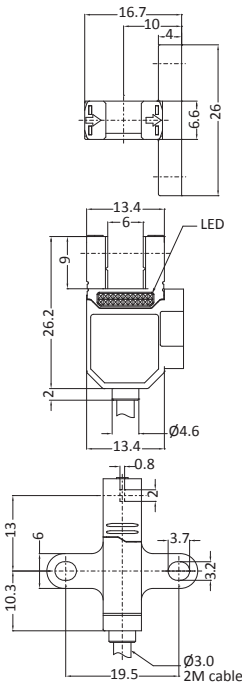

### • RX-676-NW/PW

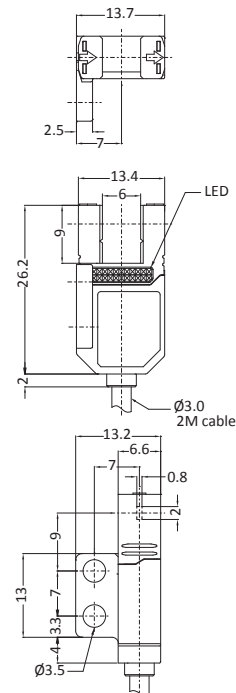

### • RX-677-NW/PW

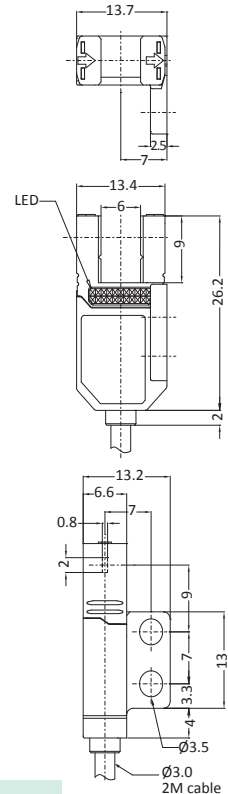

## Wiring diagrams / 接線圖

### NPN Output

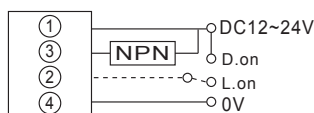

### PNP Output

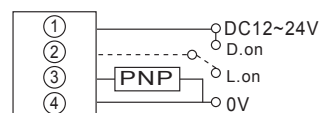

## Characteristic / 特點：

- Ultra slim body, 13mm thickness only.  
/ 13mm超薄型，寬度僅有30mm。
- Min. Detectable object Ø60mm.  
/ 最小檢測物Ø60mm。
- Green and red LED blink in sequence from top to bottom under normal emission. All LED light up under the emitting circuit failure.  
/ 未感應時，綠色與紅色LED依序閃爍，當有物體遮斷時，LED則全部一起亮。

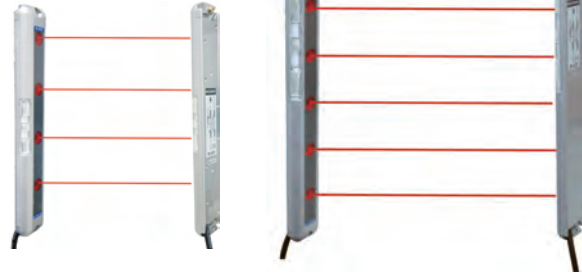
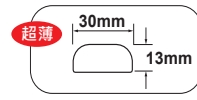

Model / 型號	NPN D.on	OAP-4004-NK	OAP-4004S-NK	OAP-4008-NK	OAP-4008S-NK
	NPN L.on	OAP-4004-N2K	OAP-4004S-N2K	OAP-4008-N2K	OAP-4008S-N2K
	PNP D.on	OAP-4004-PK	OAP-4004S-PK	OAP-4008-PK	OAP-4008S-PK
	PNP L.on	OAP-4004-P2K	OAP-4004S-P2K	OAP-4008-P2K	OAP-4008S-P2K
No.of Beams / 光軸數	4		8		
Sensing Height / 檢測高度	120 mm		280 mm		
Beam pitch / 光軸間距	40 mm				
Sensing type / 檢出方式	Through beam / 對照式				
Resolution / 分辨率	60 mm opaque object 不透明物體				
Sensing distance / 檢出距離	0.1 M ~ 5 M	0.1 M ~ 2 M	0.2 M ~ 5 M	0.2 M ~ 2 M	
Emitting light / 發光源	Infrared LED : 850 nm				
Indicating LED / LED指示燈	5 LEDs each on emitter and receiver. / 在發射端與接收端各有5個LED燈		7 LEDs each on emitter and receiver. / 在發射端與接收端各有7個LED燈		
	LEDs blink from top to bottom under the normal emission. All LEDs light up under the emitting circuit failure and will become blinking until the normal emission. / 在正常通電情況下，LED燈由上而下的閃爍。在發射端光軸被阻隔時，所有LED燈會全亮。如果恢復正常，即發射端光軸不被阻隔，LED恢復由上往下的閃爍				
Running type / 運轉方式	More than a beam is covered ON ( Dark On ) 任意一個光束被遮斷即輸出				
Operating voltage / 工作電壓	DC12 ~ 24 V ± 10% (ripple P-P : 10% Max.)				
Current consumption / 消耗電流	Transmitter : 30 mA Max.		Transmitter : 60 mA Max.		
	Receiver : 15 mA Max.		Receiver : 30 mA Max.		
Load current / 負載電流	100 mA 最大 at DC 24V				
Protection circuit / 保護電路	Reversed Supply circuit protection, Short circuit protection output. / 電源反接保護及輸出短路保護				
Response time / 反應時間	Off to On : 15 ms Max.				
	On to Off : 20 ms Max.				
Insulation resistance / 隔離阻抗	20MΩ min. (DC500V)				
Voltage withstandability / 絕緣耐壓	AC1000V 60Hz for 60 Sec.				
Operating temperature / 工作溫度	- 10 °C ~ + 45°C (No freezing allowed 不可結霜,結冰)				
Ambient humidity / 工作溼度	35% ~ 85% RH 相對溼度				
Storage temperature / 儲存時溫度	- 10 °C ~ + 45°C (No freezing allowed 不可結霜,結冰)				
Storage humidity / 儲存時溼度	35% ~ 95% RH 相對溼度				
Protection degree / 防水等級	IP62				
Material / 外觀材質	ABS				
Wiring method / 出線方式	Transmitter : M12 pigtailed type(5P) / M12 出線式接頭型				
	Receiver : M12 pigtailed type(5P) / M12 出線式接頭型				
Option / 選購配件	OAP-M008 Mounting Bracket / OAP-M008固定架		OAP-M016 Mounting Bracket / OAP-M016固定架		
	Connectors / 線材 : M125R-PUR-2M / M125R-PUR-5M				
Weight / 重量	200g		253g		

## Dimensions / 尺寸圖 (mm)

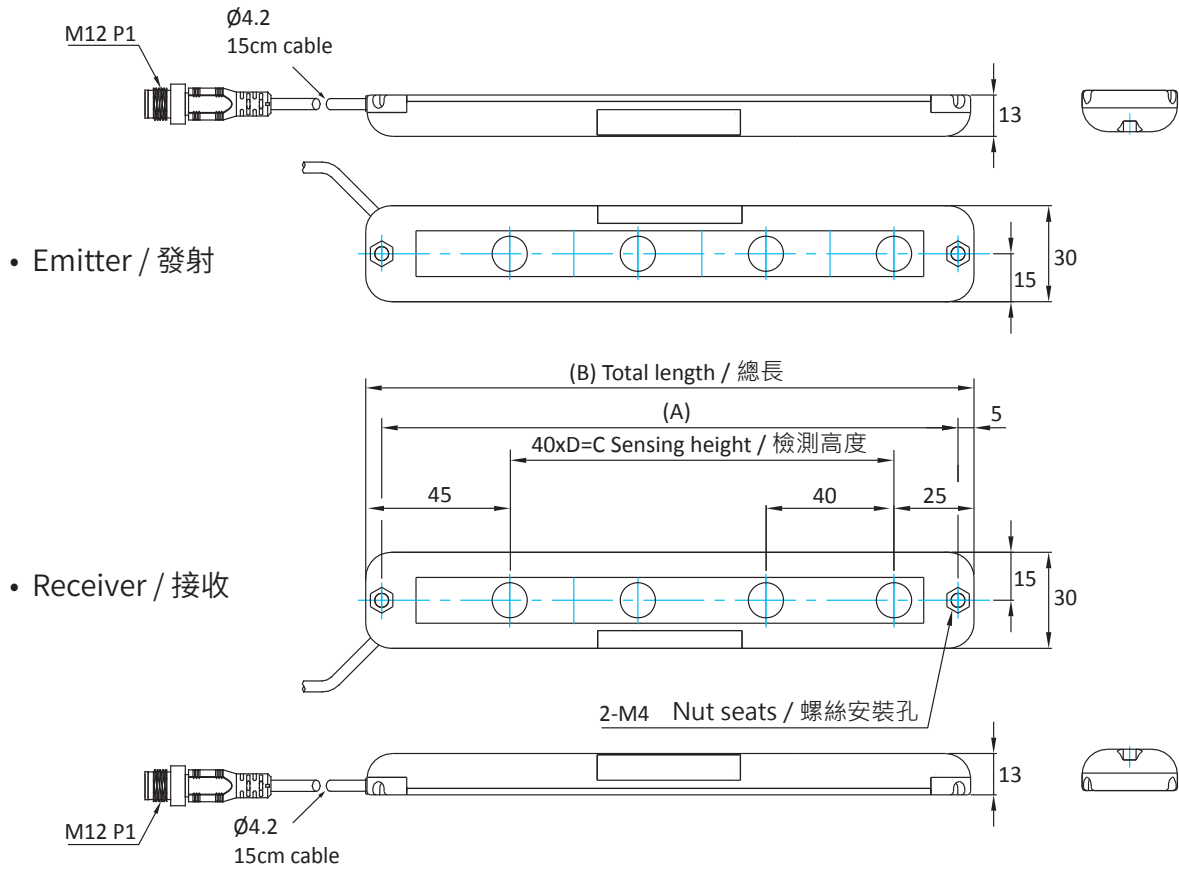

Model / 型號	(A)	(B)	(C)	(D)
OAP-4004(S)-□K	180mm	190mm	120mm	3
OAP-4008(S)-□K	340mm	350mm	280mm	7

## Wiring diagrams / 接線圖

• Emitter / 發射

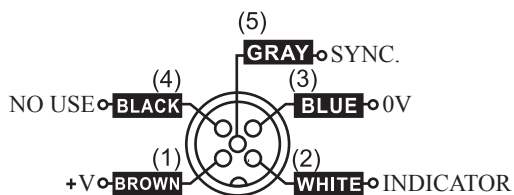

• Receiver / 接收

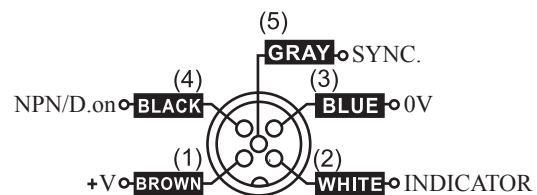

## Characteristic / 特點：

- Ultra slim body, 13mm thickness only.  
/ 13mm超薄型，寬度僅有30mm。
- Min. Detectable object Ø30mm.  
/ 最小檢測物Ø30mm。
- Green and red LED blink in sequence from top to bottom under normal emission. All LED light up under the emitting circuit failure.  
/ 未感應時，綠色與紅色LED依序閃爍，當有物體遮斷時，LED則全部一起亮。

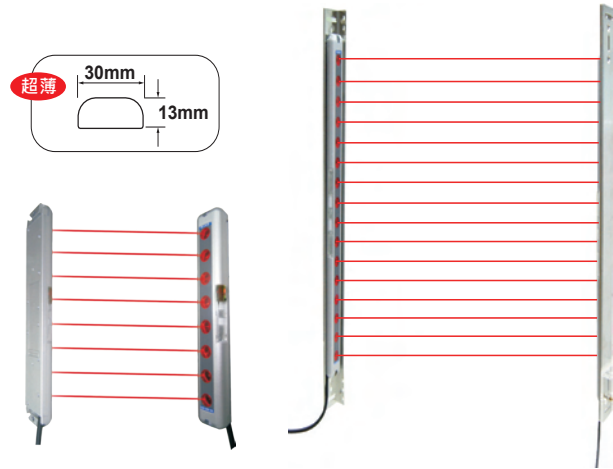

OAP

光電—光柵—超音波感測器

R5JM  
R3JK  
LK  
LRS  
PK3  
PKG3  
PK5  
PM6

PTQ18  
RMF  
MMF

SU07  
SU  
SU18  
SU30

SPR  
RX

OAP  
ASP

RU18

Model / 型號	NPN D.on	OAP-2008-NK	OAP-2008S-NK	OAP-2016-NK	OAP-2016S-NK
	NPN L.on	OAP-2008-N2K	OAP-2008S-N2K	OAP-2016-N2K	OAP-2016S-N2K
	PNP D.on	OAP-2008-PK	OAP-2008S-PK	OAP-2016-PK	OAP-2016S-PK
	PNP L.on	OAP-2008-P2K	OAP-2008S-P2K	OAP-2016-P2K	OAP-2016S-P2K
Sensing type / 檢出方式	Through beam / 對照式				
Resolution / 分辨率	60 mm opaque object 不透明物體				
Sensing distance / 檢出距離	0.6 M ~ 5 M	0.3 M ~ 2 M	0.9 M ~ 5 M	0.5 M ~ 2 M	
Sensing Height / 檢測高度	140 mm		300 mm		
Emitting light / 發光源	Infrared LED : 850 nm				
No.of Beams / 光軸數	8		16		
Beam pitch / 光軸間距	20 mm				
Indicating LED / LED指示燈	5 LEDs each on emitter and receiver. / 在發射端與接收端各有5個LED燈		7 LEDs each on emitter and receiver. / 在發射端與接收端各有7個LED燈		
Running type / 運轉方式	More than a beam is covered ON ( Dark On ) 任意一個光束被遮斷即輸出				
Operating voltage / 工作電壓	DC12 ~ 24 V±10% (ripple P-P : 10% Max.)				
Current consumption / 消耗電流	Transmitter : 90 mA Max. Receiver : 35 mA Max.		Transmitter : 135 mA Max. Receiver : 70 mA Max.		
Load current / 負載電流	100 mA Max at DC 24V				
Protection circuit / 保護電路	Reversed Supply circuit protection, Short circuit protection output. / 電源反接保護及輸出短路保護				
Response time / 反應時間	Off to On : 15 ms Max. On to Off : 20 ms Max.				
Insulation resistance / 隔離阻抗	20MΩ min. (DC500V)				
Voltage withstandability / 絕緣耐壓	AC1000V 60Hz for 60 Sec.				
Operating temperature / 工作溫度	- 10 °C ~ + 45°C (No freezing allowed 不可結霜,結冰)				
Ambient humidity / 工作溼度	35% ~ 85% RH 相對溼度				
Storage temperature / 儲存時溫度	- 10 °C ~ + 45°C (No freezing allowed 不可結霜,結冰)				
Storage humidity / 儲存時溼度	35% ~ 95% RH 相對溼度				
Protection degree / 防水等級	IP62				
Material / 外觀材質	ABS				
Wiring method / 出線方式	Transmitter : M12 pigtailed type(5P) / M12 出線式接頭型 Receiver : M12 pigtailed type(5P) / M12 出線式接頭型				
Option / 選購配件	OAP-M008 Mounting Bracket / OAP-M008固定架		OAP-M016 Mounting Bracket / OAP-M016固定架		
Weight / 重量	200g		253g		

## Dimensions / 尺寸圖 (mm)

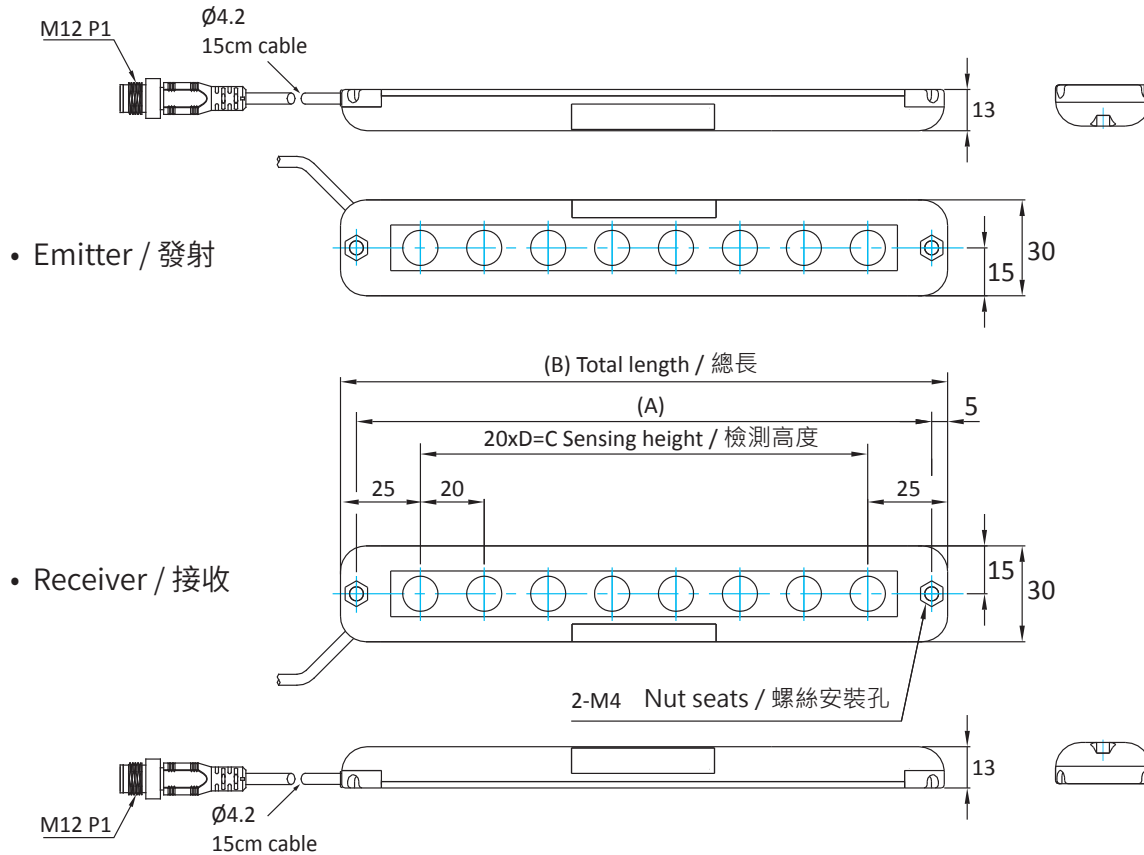

Model / 型號	(A)	(B)	(C)	(D)
OAP-2008(S)-□K	180mm	190mm	140mm	7
OAP-2016(S)-□K	340mm	350mm	300mm	15

## Wiring diagrams / 接線圖

### • Emitter / 發射

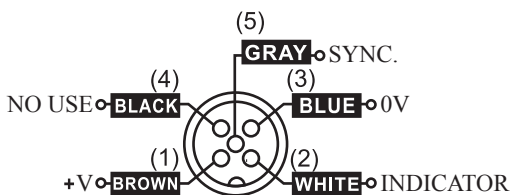

### • Receiver / 接收

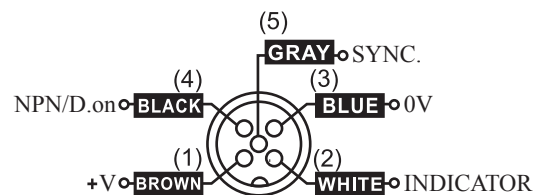

## Mounting / 安裝方式

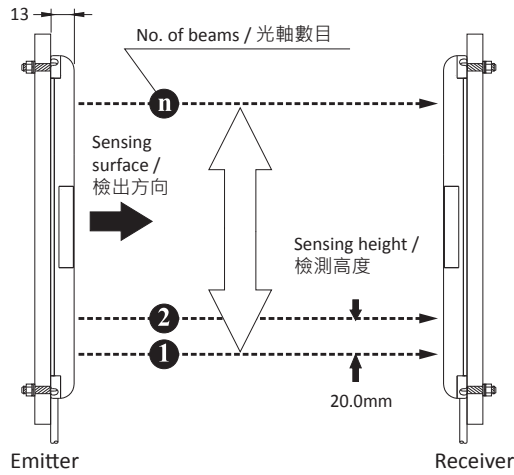

## OAP-Bracket Mounting / OAP固定架安裝方式

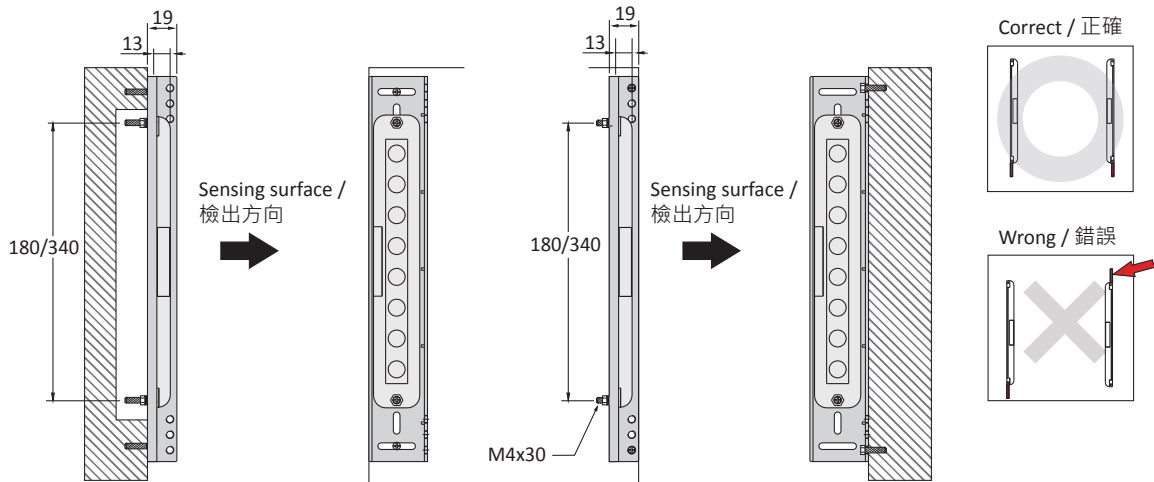

## Indicator / 指示燈

Without objects passing. / 無感測物通過時

With objects passing. / 感測物通過時

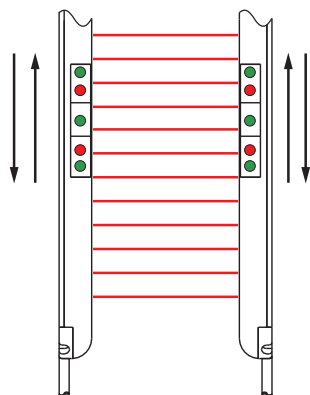

LEDs blink to and fro. / LED來回持續閃爍

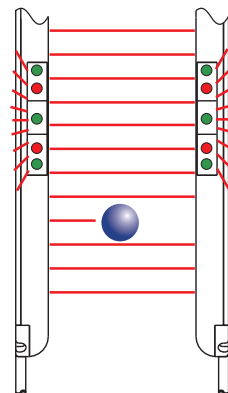

All LEDs light up. / LED全部亮起

Model	Without objects passing. / 無被測物通過	With objects passing. / 有被測物通過
<b>OAP-2008</b>	5 LEDs blink to and fro (from top to bottom). (Green,Red,Green,Red,Green)	All 5 LEDs light up. (Green,Red,Green,Red,Green)
<b>OAP-2016</b>	7 LEDs blink to and fro (from top to bottom). (Green,Red,Green,Red,Green,Red,Green)	All 7 LEDs light up. (Green,Red,Green,Red,Green,Red,Green)

## Wiring diagrams / 接線圖

Emitter / 發射

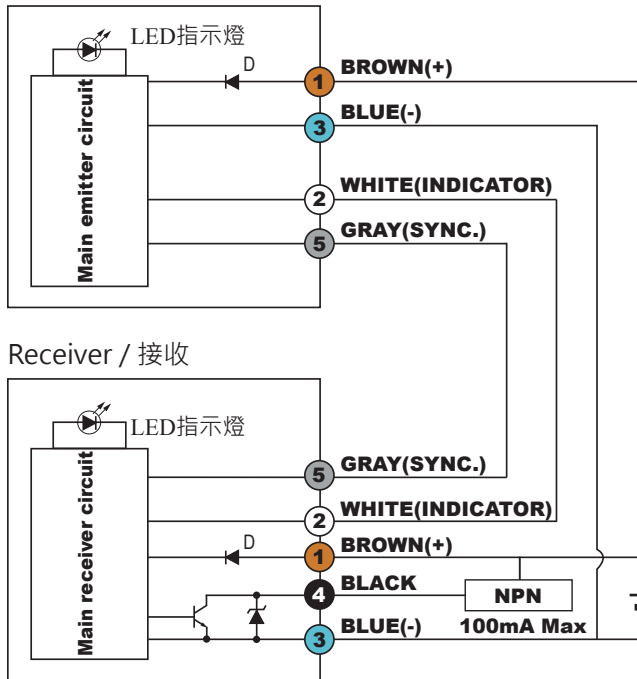

LOAD/ 負載  
NPN open collector output.  
Max current 100mA.  
supplying voltage DC12~24V.

NPN最開放集極電路  
最大輸出電流100mA  
供應電壓DC12~24V

## Engineering data / 工程數據

OAP-2008-□ Angular deviation / 角度偏差

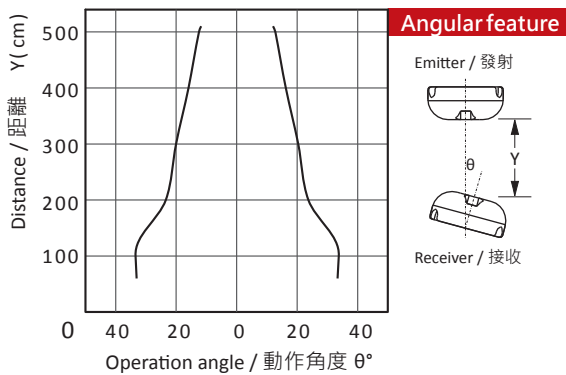

OAP-2016-□ Angular deviation / 角度偏差

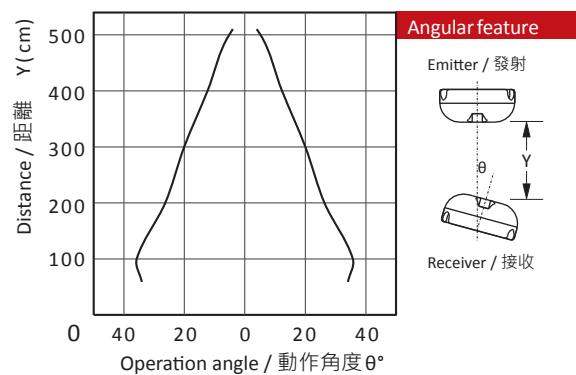

OAP-2008S-□ Angular deviation / 角度偏差

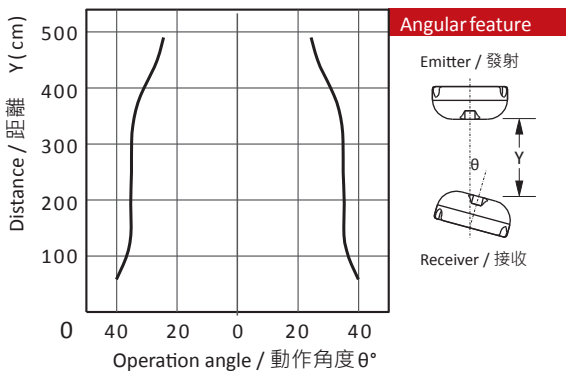

OAP-2016S-□ Angular deviation / 角度偏差

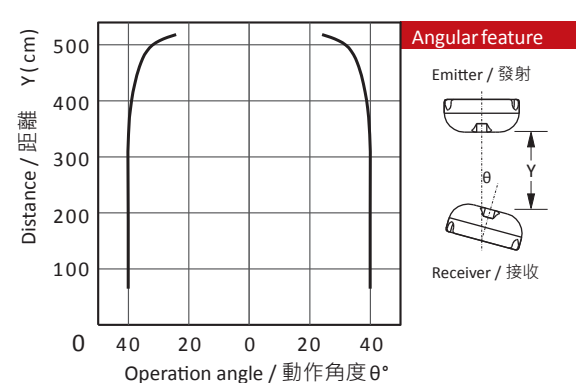

OAP

光電—光柵—超音波感測器

R5JM  
R3JK  
LK  
LRS  
PK3  
PKG3  
PK5  
PM6

PTQ18  
RMF  
MMF

SU07  
SU  
SU18  
SU30

SPR  
RX

OAP  
ASP

RU18

## Timer chart / 時序圖

### • OAP-2008-□

#### Emitter / 發射

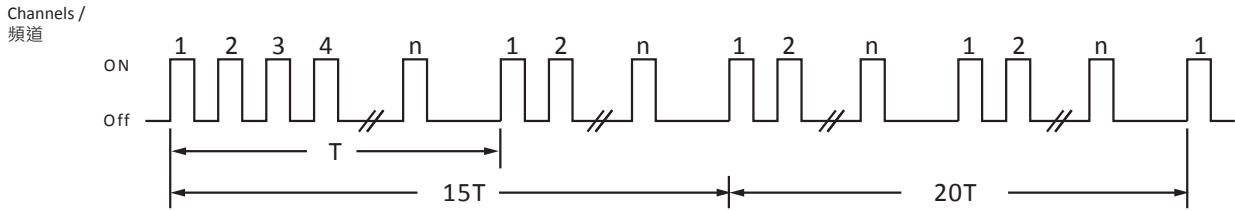

#### Receiver / 接收

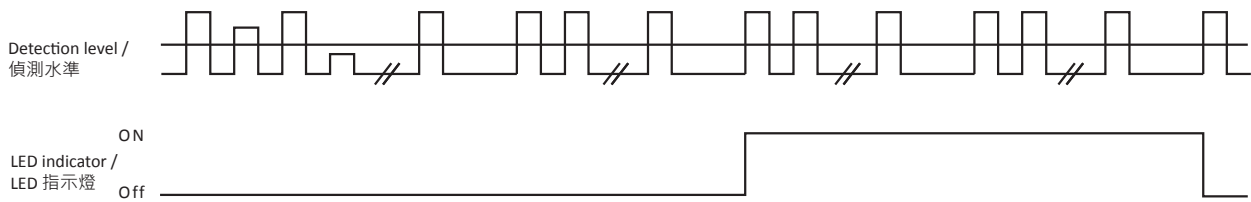

### • OAP-2016-□

#### Emitter / 發射

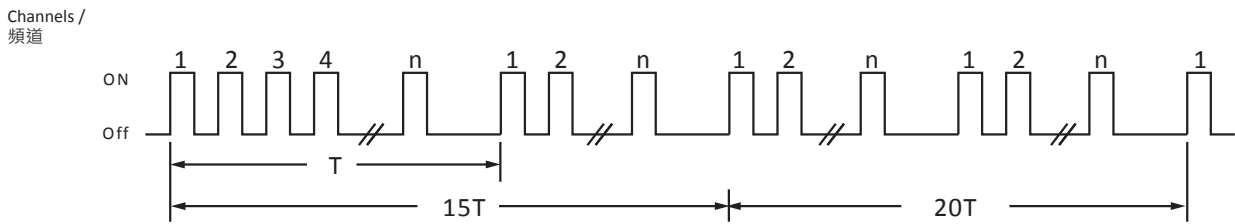

#### Receiver / 接收

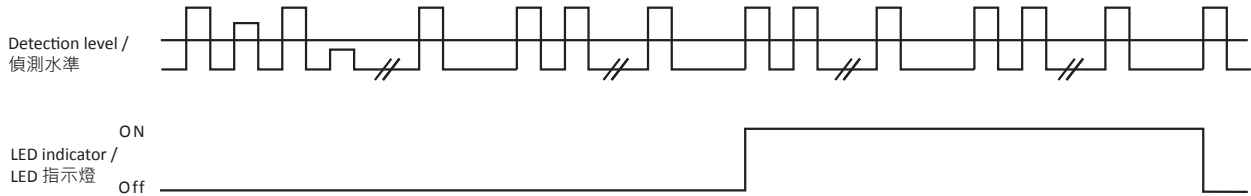

OAP

光電  
— 光柵 —  
超音波感測器

R5JM  
R3JK  
LK  
LRS  
PK3  
PKG3  
PK5  
PM6

PTQ18  
RMF  
MMF

SU07  
SU  
SU18  
SU30

SPR  
RX

OAP  
ASP

RU18

## Attention / 注意事項

### ⚠ Warning1 / 警告1

This product is not permitted to use with the machines which are not stopped electronically by electronic control. / 不可使用於無立即停止電子控制式的機器。

### ⚠ Warning2 / 警告2

Be sure to set some amount of safe distance between the sensor and dangerous point. / 在感應器及危險區域間，必須保持安全距離。

- Safe distance (D) formula. Min distance is 150mm. / 安全距離(D)公式。最短距離150mm。

$$D=2000 \times T+\alpha \quad (D \leq 500\text{mm})$$

$$D=1600 \times T+\alpha \quad (D > 500\text{mm})$$

D=safe distance (mm)

T=response time (machine+sensor)

反應時間= (機器的反應時間+感應器的反應時間)

$\alpha=90\text{mm}$

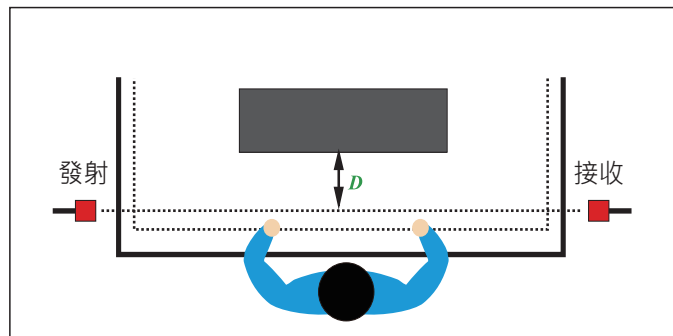

### ⚠ Warning3 / 警告3

Let worker keep working through the detecting range. / 在感測範圍內進行工作。

◆Correct / 正確

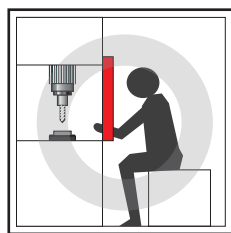

◆Wrong / 錯誤

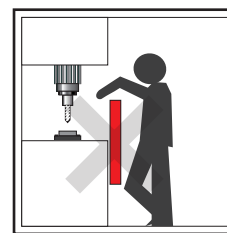
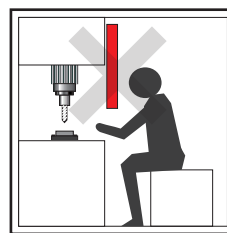

### ⚠ Warning4 / 警告4

When installing, please think of other reflecting object which may cause malfunction. / 安裝時，考慮是否有其它會導致機能故障的反射物。

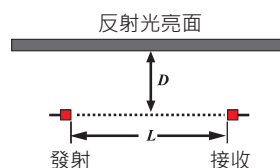
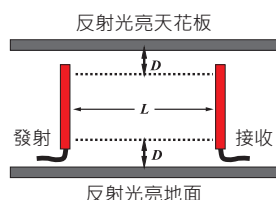

Acceptable installation distance / 可接受的安裝範圍  
 $D \geq 150\text{mm}$   
 $L=0.3\sim 5\text{M}$

## Characteristic / 特點 :

- High resolution area sensor.  
/ 高解晰區域感測器。
- Durable aluminum extrusion structure.  
/ 鋁擠一體成型，堅固好用。
- 100 light beam, detect 3mm thin.  
/ 100光軸數，3mm 薄的檢測。
- Response time 4.2ms.  
/ 快速反應時間 4.2ms。



ASP

光電 / 光柵 / 超音波感測器

R5JM  
R3JK  
LK  
LRS  
PK3  
PKG3  
PK5  
PM6

PTQ18  
RMF  
MMF

SU07  
SU  
SU18  
SU30

SPR  
RX

OAP  
ASP

RU18

Model / 型號	NPN. NC	<b>ASP-01-100-SN2-K1</b>
No.of Beams / 光軸數		100 beam
Sensing height / 檢測高度		100 mm
Resolution / 分辨率		3 mm
Sensing type / 檢出方式		Through beam / 對照式
Operating distance / 檢測距離		0.3M~ 3M
Operating voltage / 工作電壓		10~ 30 VDC
Current Consumption / 消耗電流		Transmitter: <60mA , Receiver: <30mA
Operating temperature / 工作溫度		-40°C ~ 70°C
Protection degree / 防護等級		IP65
Casing material / 外殼材料		Aluminum
Connection / 連接方式		M12-4Pin 附動作LED

## Dimensions / 尺寸圖 (mm)

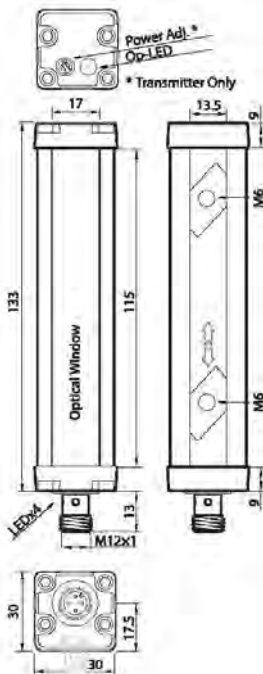

## Wiring diagrams / 接線圖

-N

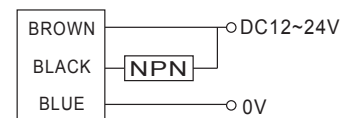

## Characteristic / 特點：

- Light pitch 10mm. Detecting different shaped targets.  
/ 光軸間距10mm，可檢知不規則物品。
- Light bar output indicators.  
/ 專利Light-bar動作指示燈。
- Durable aluminum extrusion structure.  
/ 鋁擠型結構，堅固耐用。
- NP model: NPN or PNP, L.on or D.on selectable.  
/ 新型NP電路：NPN或PNP，L.on 或D.on可選擇。

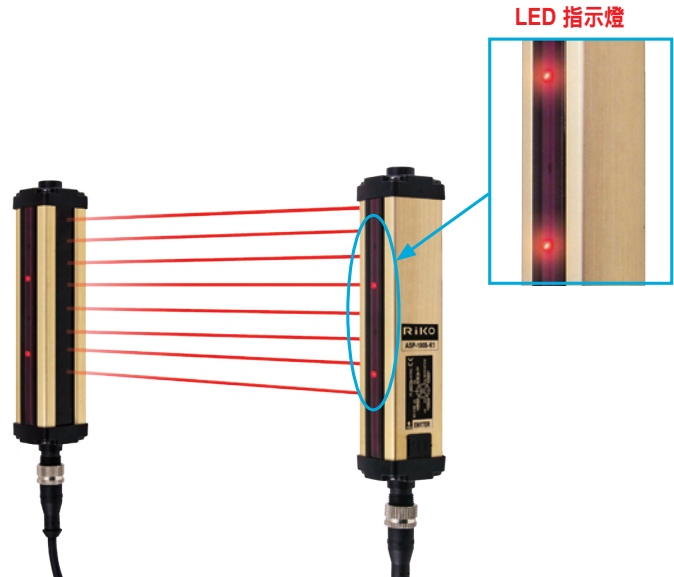

Model / 型號	NPN or PNP L.on/D.on	ASP-1008-K1
No.of Beams / 光軸數		8
Sensinf Height / 檢測高度		70 mm
Beam pitch / 光軸間距		10 mm
Sensing type / 檢出方式		Through beam / 對照式
Resolution / 分辨率		15 mm opaque object 不透明物體
Sensing distance / 檢出距離		0.3 M ~ 1.5 M
Emitting light / 發光源		Infrared LED : 850 nm
Indication LED / LED指示燈		Blinking or shining output indicators. / 動作指示燈有閃爍式、恆亮式
Running type / 運轉方式		More than one beam is covered ON (Dark On) / 任意一個光束被遮斷即輸出
Operating voltage / 工作電壓		DC12 ~ 24 V±10% (ripple P-P : 10% Max.)
Current consumption / 消耗電流		Transmitter : 45 mA Max. Receiver : 35 mA Max.
Load current / 負載電流		100 mA Max. at DC 24V
Protection circuit / 保護電路		Reversed Supply circuit protection, Short circuit protection output / 電源反接保護及輸出短路保護
Response time / 反應頻率		2000 Hz
Insulation resistance / 隔離阻抗		20MΩ min. (DC500V)
Voltage withstandability / 絕緣耐壓		AC1000V 60Hz for 60 Sec.
Operating temperature / 工作溫度		- 10 °C ~ + 45°C (No freezing allowed / 不可結霜,結冰)
Ambient humidity / 工作溼度		35% ~ 85% RH 相對溼度
Storage temperature / 儲存時溫度		- 10 °C ~ + 45°C (No freezing allowed / 不可結霜,結冰)
Storage humidity / 儲存時溼度		35% ~ 95% RH 相對溼度
Protection degree / 防水等級		IP62
Meterial / 外觀材質		Aluminum+ABS / 鋁+ABS
Wiring method / 出線方式		Transmitter : M12 pigtailed type(5P) Receiver : M12 pigtailed type(5P)
Option / 選購配件		Connectors / 線材 : M125R-PUR-2M / M125R-PUR-5M
Weight / 重量		220g

## Dimensions / 尺寸圖 (mm)

- Emitter / 發射

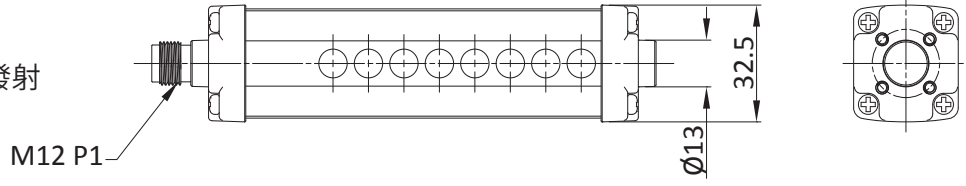

- Receiver / 接收

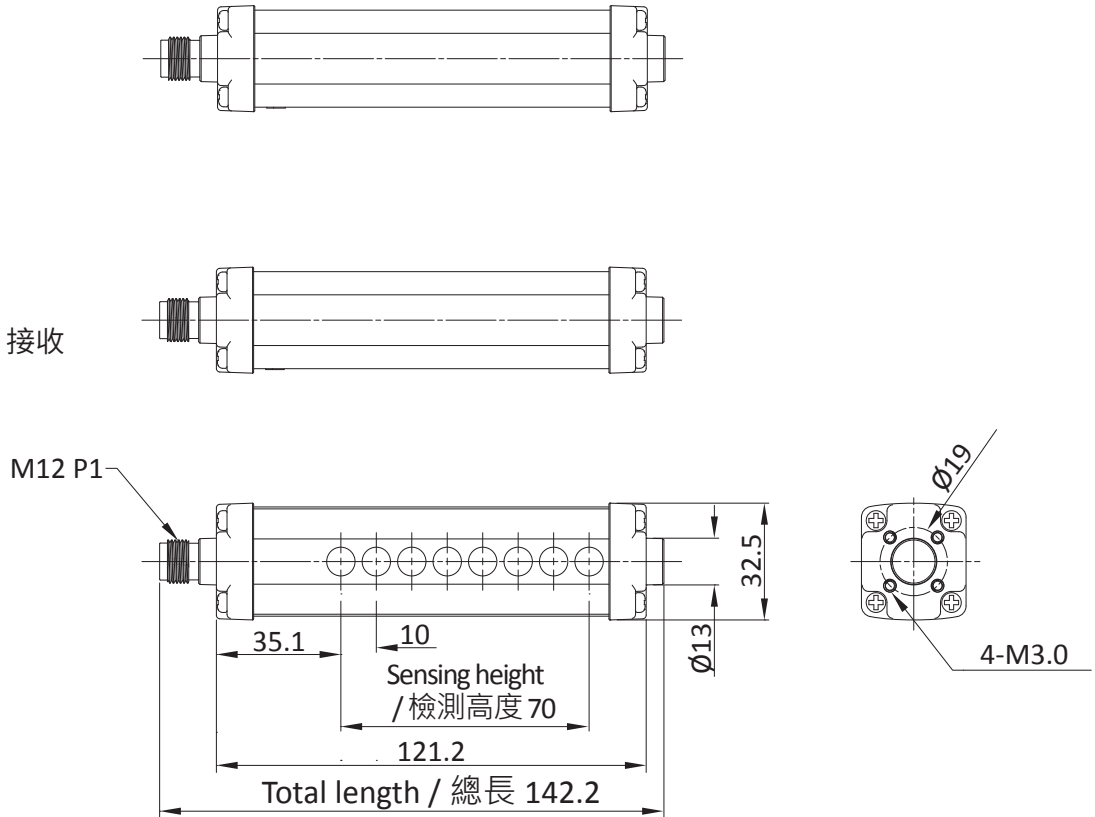

- ASP-Bracket / ASP固定架

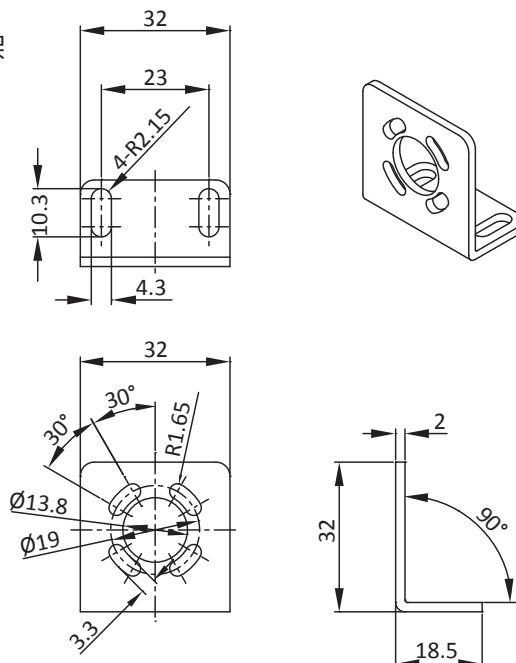

ASP

光電 / 光柵 / 超音波感測器

R5JM  
R3JK  
LK  
LRS  
PK3  
PKG3  
PK5  
PM6

PTQ18  
RMF  
MMF

SU07  
SU  
SU18  
SU30

SPR  
RX

OAP  
ASP

RU18

## ASP-1008-K1 DIP Switch / ASP-1008-K1指撥開關：

- Receiver/ 接收

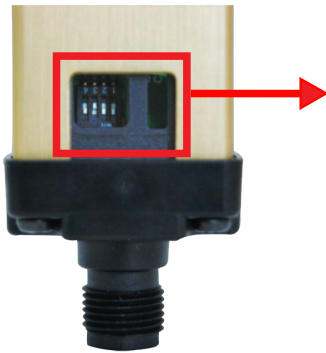

- 4.N.C./N.C.(無功能)
- 3.NPN/PNP 輸出
- 2.FLASH/FIX(閃爍/不閃爍)
- 1.D.ON/L.ON(遮光/入光動作)

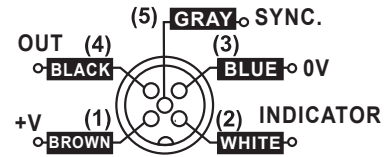

## Wiring diagrams / 接線圖

### Emitter / 發射

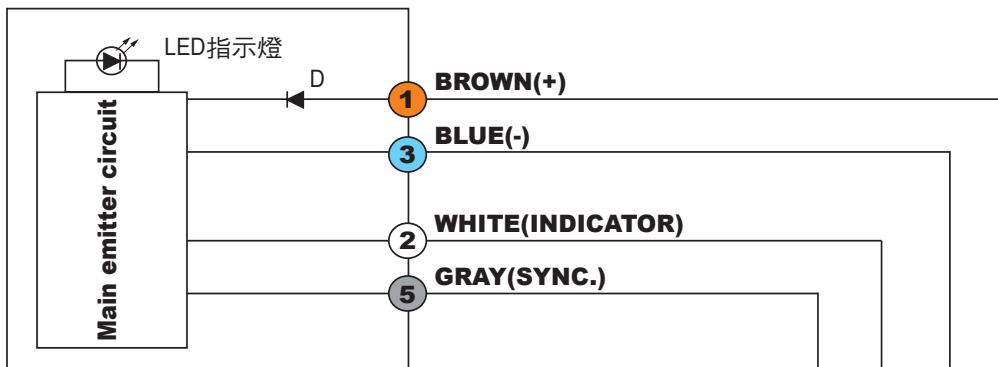

### Receiver / 接收

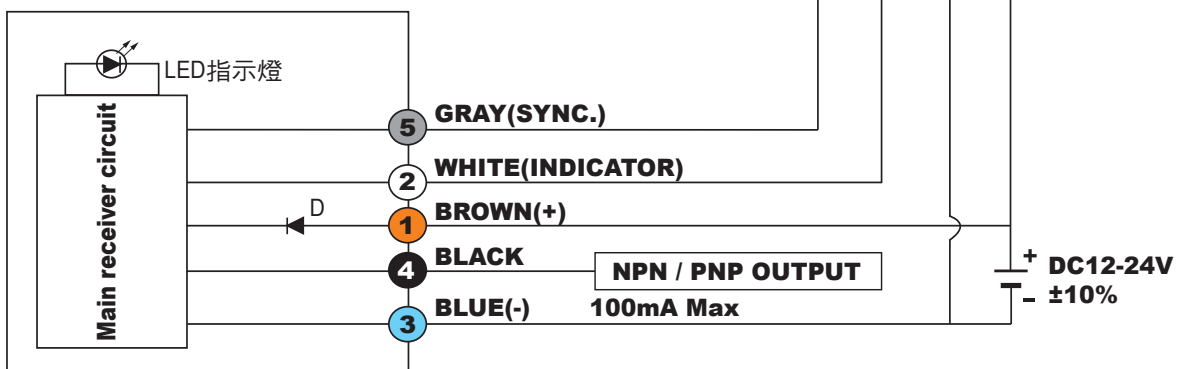

## Characteristic / 特點：

- Durable aluminum extrusion structure.  
/ 鋁擠型結構，堅固耐用。
- Dip setting: CW. (installing forwards) / CCW. (installing reverse side) complied with machinery wiring.  
/ DIP 可設定CW.正向，CCW.反向安裝，配合機台配線。
- NP model: NPN or PNP, L.on or D.on selectable.  
/ 新型NP電路：NPN或PNP，L.on或D.on可選擇。

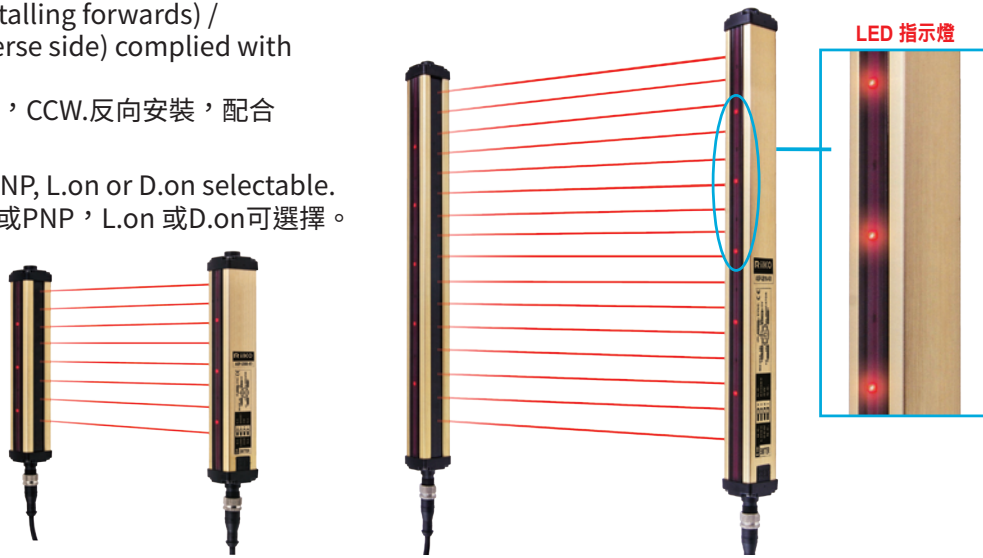

Model / 型號	NPN or PNP L.on/D.on	ASP-2008-K1	ASP-2016-K1	ASP-2024-K1	ASP-2032-K1
		ASP-2008S-K1	ASP-2016S-K1	ASP-2024S-K1	ASP-2032S-K1
No.of Beams / 光軸數		8	16	24	32
Sensinf Height / 檢測高度		140 mm	300 mm	460 mm	620 mm
Beam pitch / 光軸間距		20 mm			
Sensing type / 檢出方式		Through beam / 對照式			
Resolution / 分辨率		30 mm opaque object 不透明物體			
Sensing distance / 檢出距離		0.6 M ~ 5 M 0.3 M ~ 2 M			
Dip Switch / 指撥開關 LONG/SHORT		長距：≥ 5 M / 短距：≤ 4.4 M 長距：≥ 2 M / 短距：≤ 1.8 M			
Emitting light / 發光源		Infrared LED : 850 nm			
Indication LED / LED指示燈		Blinking or shining output indicators. / 動作指示燈有閃爍式、恆亮式			
Running type / 運轉方式		More than one beam is covered ON (Dark On) / 任意一個光束被遮斷即輸出			
Operating voltage / 工作電壓		DC12 ~ 24 V±10% (ripple P-P : 10% Max.)			
Current consumption / 消耗電流		Transmitter : 45 mA Max. Receiver : 35 mA Max.	Transmitter : 60 mA Max. Receiver : 40 mA Max.	Transmitter : 70 mA Max. Receiver : 45 mA Max.	Transmitter : 90 mA Max. Receiver : 50 mA Max.
Load current / 負載電流		100 mA Max. at DC 24V			
Protection circuit / 保護電路		Reversed Supply circuit protection, Short circuit protection output. / 電源反接保護及輸出短路保護			
Response time / 反應時間		Off to On : 15 ms Max. On to Off : 20 ms Max.			
Insulation resistance / 隔離阻抗		20MΩ min. (DC500V)			
Voltage withstandability / 絕緣耐壓		AC1000V 60Hz for 60 Sec.			
Operating temperature / 工作溫度		- 10 °C ~ + 45°C (No freezing allowed不可結霜,結冰)			
Ambient humidity / 工作溼度		35% ~ 85% RH 相對溼度			
Storage temperature / 儲存時溫度		- 10 °C ~ + 45°C (No freezing allowed不可結霜,結冰)			
Storage humidity / 儲存時溼度		35% ~ 95% RH 相對溼度			
Protection degree / 防水等級		IP62			
Material / 外觀材質		Aluminum+ABS / 鋁+ABS			
Wiring method / 出線方式		Transmitter : M12 pigtailed type(5P) Receiver : M12 pigtailed type(5P)			
Option / 選購配件 (第255頁)		Connectors / 線材 : M125R-PUR-2M / M125R-PUR-5M			
Weight / 重量		320g	590g	890g	1180g

## Dimensions / 尺寸圖 (mm)

### • Emitter / 發射

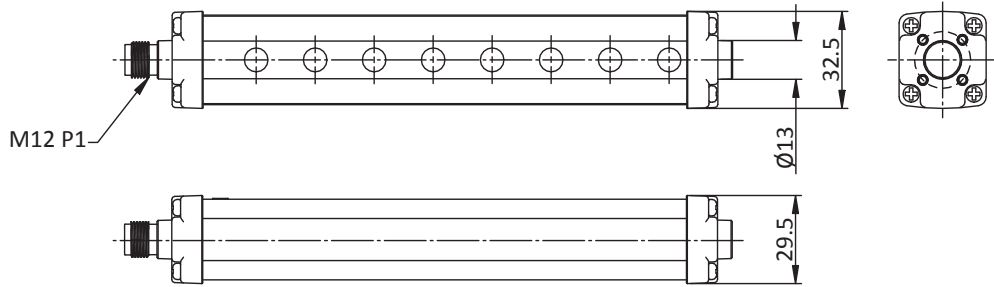

### • Receiver / 接收

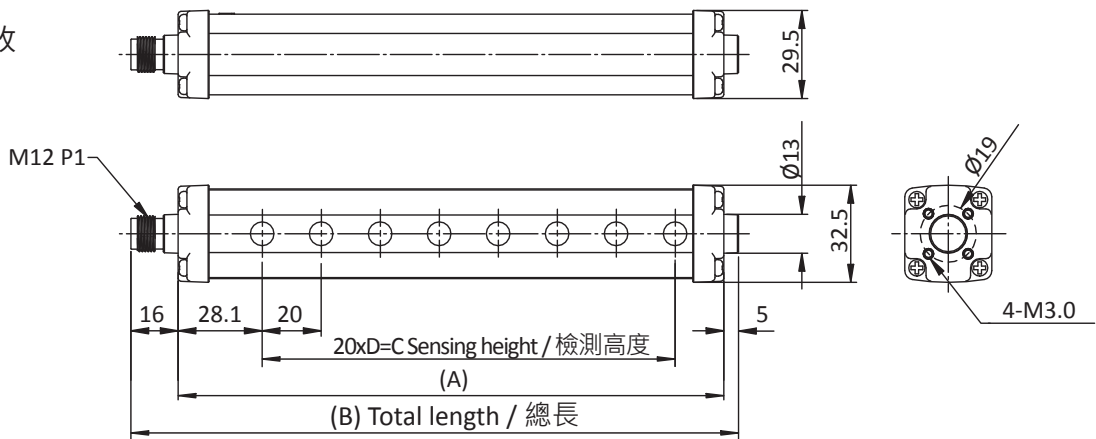

型號	(A)	(B)	(C)	(D)
ASP-2008(S)-K1	184.2mm	205.2mm	140mm	7
ASP-2016(S)-K1	344.2mm	365.2mm	300mm	15
ASP-2024(S)-K1	504.2mm	525.2mm	460mm	23
ASP-2032(S)-K1	664.2mm	685.2mm	620mm	31

### • ASP-Bracket / ASP固定架

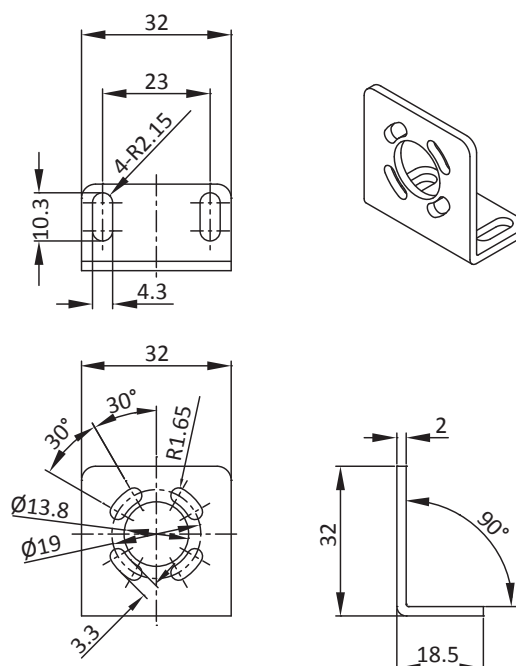

## Characteristic / 特點：

- CW. and CCW. sensing options.  
/ 正向(CW.) 反向(CCW.)掃描，安裝度自由。
- Big and bright LED output indicator.  
/ 大面積動作指示燈，清楚明瞭。
- NPN/PNP embedded outputs.  
/ 同時具備NPN/PNP，方便選擇。
- Innovative 2 types of signal pulse.  
/ 業界首創，兩段功率調整。

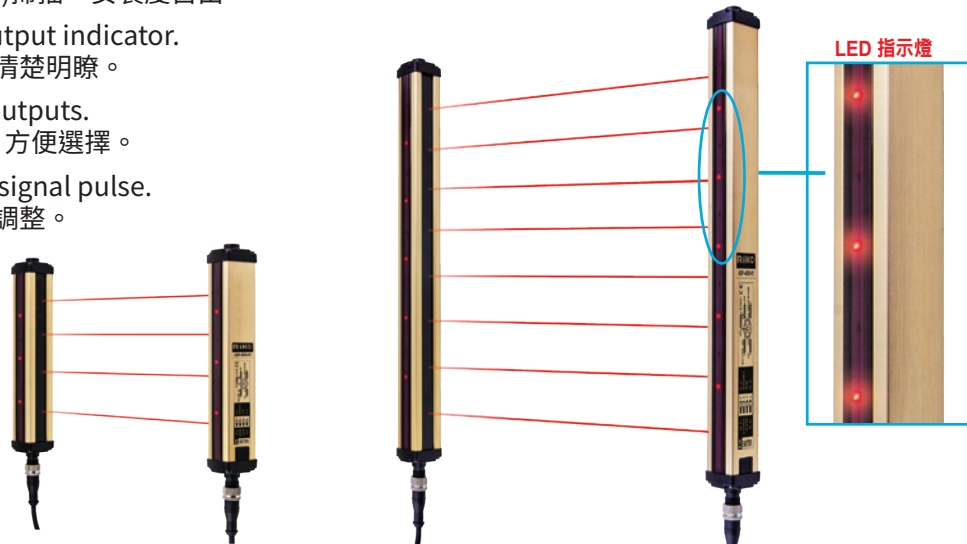

Model / 型號	NPN or PNP L.on/D.on	ASP-4004-K1	ASP-4008-K1	ASP-4012-K1	ASP-4016-K1
		ASP-4004S-K1	ASP-4008S-K1	ASP-4012S-K1	ASP-4016S-K1
No.of Beams / 光軸數		4	8	12	16
Sensing Height / 檢測高度		120 mm	280 mm	440 mm	600 mm
Beam pitch / 光軸間距		40 mm			
Sensing type / 檢出方式		Through beam / 對照式			
Resolution / 分辨率		60 mm opaque object 不透明物體			
Sensing distance / 檢出距離		0.6 M ~ 5 M 0.3 M ~ 2 M			
Dip Switch / 指撥開關 LONG/SHORT		長距：≥ 5 M / 短距：≤ 4.4 M 長距：≥ 2 M / 短距：≤ 1.8 M			
Emitting light / 發光源		紅外線 LED：850 nm			
Indication LED / LED指示燈		Blinking or shining output indicators. / 動作指示燈有閃爍式、恆亮式			
Running type / 運轉方式		More than one beam is covered ON (Dark On) / 任意一個光束被遮斷即輸出			
Operating voltage / 工作電壓		DC12 ~ 24 V ± 10% (ripple P-P：10% Max.)			
Current consumption / 消耗電流		Transmitter : 35 mA Max. Receiver : 30 mA Max.	Transmitter : 45 mA Max. Receiver : 35 mA Max.	Transmitter : 55 mA Max. Receiver : 40 mA Max.	Transmitter : 60 mA Max. Receiver : 40 mA Max.
Load current / 負載電流		100 mA Max. at DC 24V			
Protection circuit / 保護電路		Reversed Supply circuit protection, Short circuit protection output. / 電源反接保護及輸出短路保護			
Response time / 反應時間		Off to On : 15 ms Max. On to Off : 20 ms Max.			
Insulation resistance / 隔離阻抗		20MΩ min. (DC500V)			
Voltage withstandability / 絕緣耐壓		AC1000V 60Hz for 60 Sec.			
Operating temperature / 工作溫度		- 10 °C ~ + 45°C (No freezing allowed不可結霜,結冰)			
Ambient humidity / 工作溼度		35% ~ 85% RH 相對溼度			
Storage temperature / 儲存時溫度		- 10 °C ~ + 45°C (No freezing allowed不可結霜,結冰)			
Storage humidity / 儲存時溼度		35% ~ 95% RH 相對溼度			
Protection degree / 防水等級		IP62			
Material / 外觀材質		Aluminum+ABS / 鋁+ABS			
Wiring method / 出線方式		Transmitter : M12 pigtailed type(5P) Receiver : M12 pigtailed type(5P)			
Option / 選購配件 (第255頁)		Connectors / 線材：M125R-PUR-2M / M125R-PUR-5M			
Weight / 重量		315g	580g	875g	1160g

### Characteristic / 特點：

- CW. and CCW. sensing options.  
/ 正向(CW.) 反向(CCW.)掃描，安裝度自由。
- Big and bright LED output indicator.  
/ 大面積動作指示燈，清楚明瞭。
- NPN/PNP embedded outputs.  
/ 同時具備NPN/PNP，方便選擇。
- Innovative 2 types of signal pulse.  
/ 業界首創，兩段功率調整。

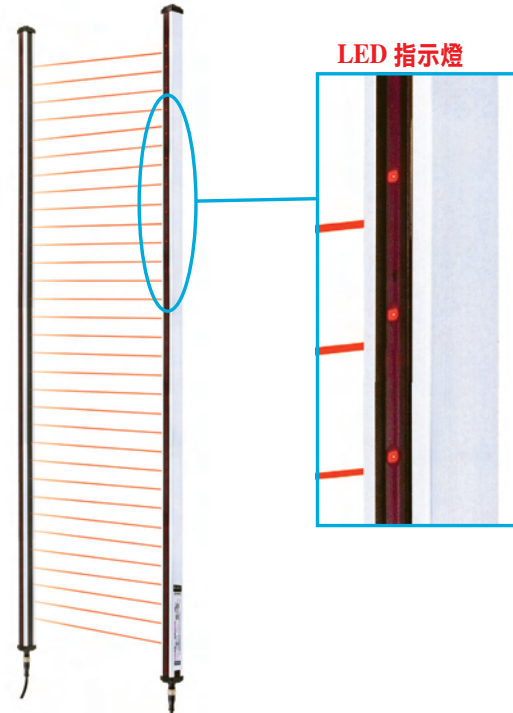

Model / 型號	NPN or PNP L.on/D.on	ASP-4024-K1	ASP-4036-K1
		ASP-4024S-K1	ASP-4036S-K1
No.of Beams / 光軸數		24	36
Sensinf Height / 檢測高度		920 mm	1400 mm
Beam pitch / 光軸間距		40 mm	
Sensing type / 檢出方式		Through beam / 對照式	
Resolution / 分辨率		60 mm opaque object 不透明物體	
Sensing distance / 檢出距離		0.6 M ~ 5 M 0.3 M ~ 2 M	
Dip Switch / 指撥開關 LONG/SHORT		長距：> 5 M / 短距：< 4.8 M 長距：> 2 M / 短距：< 1.9 M	長距：> 5 M / 短距：< 4.4 M 長距：> 2 M / 短距：< 1.5 M
Emitting light / 發光源		紅外線 LED：850 nm	
Indication LED / LED指示燈		Blinking or shining output indicators. / 動作指示燈有閃爍式、恆亮式	
Running type / 運轉方式		More than one beam is covered ON (Dark On) / 任意一個光束被遮斷即輸出	
Operating voltage / 工作電壓		DC12 ~ 24 V ± 10% (ripple P-P：10% Max.)	
Current consumption / 消耗電流		Transmitter：85 mA Max. Receiver：35 mA Max.	Transmitter：85 mA Max. Receiver：60 mA Max.
Load current / 負載電流		100 mA Max. at DC 24V	
Protection circuit / 保護電路		Reversed Supply circuit protection, Short circuit protection output. / 電源反接保護及輸出短路保護	
Response time / 反應時間		Off to On：15 ms Max. On to Off：20 ms Max.	
Insulation resistance / 隔離阻抗		20MΩ min. (DC500V)	
Voltage withstandability / 絕緣耐壓		AC1000V 60Hz for 60 Sec.	
Operating temperature / 工作溫度		- 10 °C ~ + 45°C (No freezing allowed不可結霜,結冰)	
Ambient humidity / 工作溼度		35% ~ 85% RH 相對溼度	
Storage temperature / 儲存時溫度		- 10 °C ~ + 45°C (No freezing allowed不可結霜,結冰)	
Storage humidity / 儲存時溼度		35% ~ 95% RH 相對溼度	
Protection degree / 防水等級		IP62	
Meterial / 外觀材質		Aluminum+ABS / 鋁+ABS	
Wiring method / 出線方式		Transmitter：M12 pigtailed type(5P) Receiver：M12 pigtailed type(5P)	
Option / 選購配件 (第255頁)		Connectors / 線材：M125R-PUR-2M / M125R-PUR-5M	
Weight / 重量		1700g	2455g

## Dimensions / 尺寸圖 (mm)

- Emitter / 發射

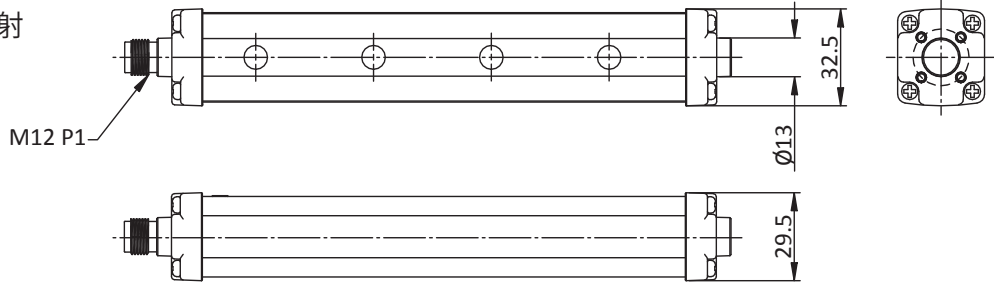

- Receiver / 接收

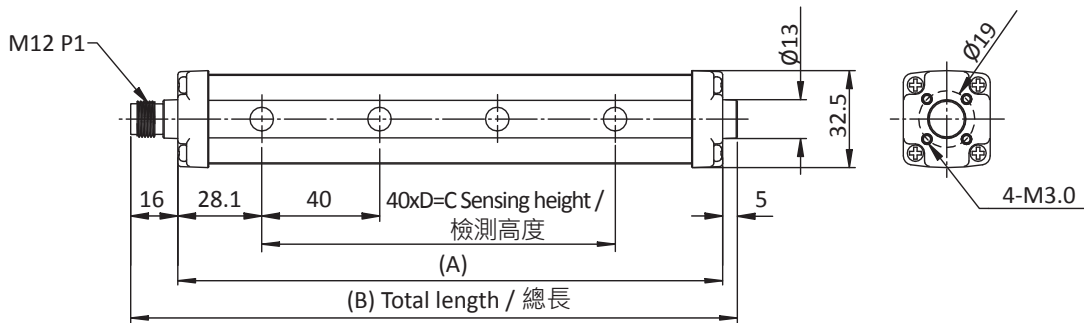

型號	(A)	(B)	(C)	(D)
<b>ASP-4004(S)-K1</b>	184.2mm	205.2mm	120mm	3
<b>ASP-4008(S)-K1</b>	344.2mm	365.2mm	280mm	7
<b>ASP-4012(S)-K1</b>	504.2mm	525.2mm	440mm	11
<b>ASP-4016(S)-K1</b>	664.2mm	685.2mm	600mm	15
<b>ASP-4024(S)-K1</b>	984.2mm	1005.2mm	920mm	23
<b>ASP-4036(S)-K1</b>	1464.2mm	1485.2mm	1400mm	35

- ASP-Bracket / ASP固定架

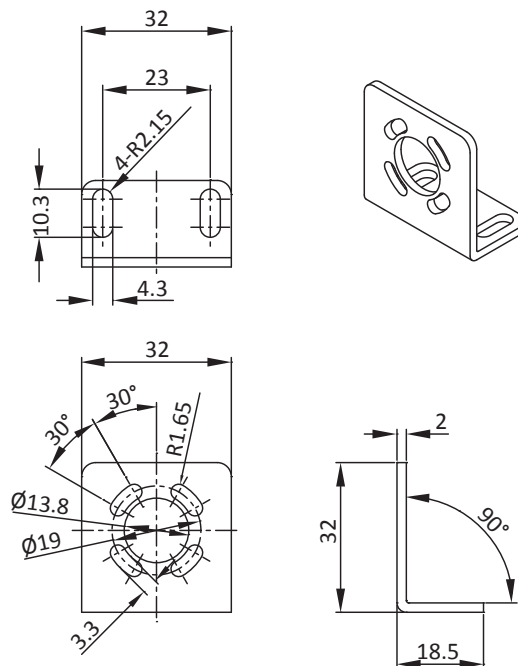

## ASP-1008-K1 DIP Switch / ASP-1008-K1指撥開關：

- Emitter / 發射

ASP-2008(S)-K1 / ASP-2016(S)-K1 / ASP-2024(S)-K1 / ASP-2032(S)-K1  
ASP-4004(S)-K1 / ASP-4008(S)-K1 / ASP-4012(S)-K1 / ASP-4016(S)-K1

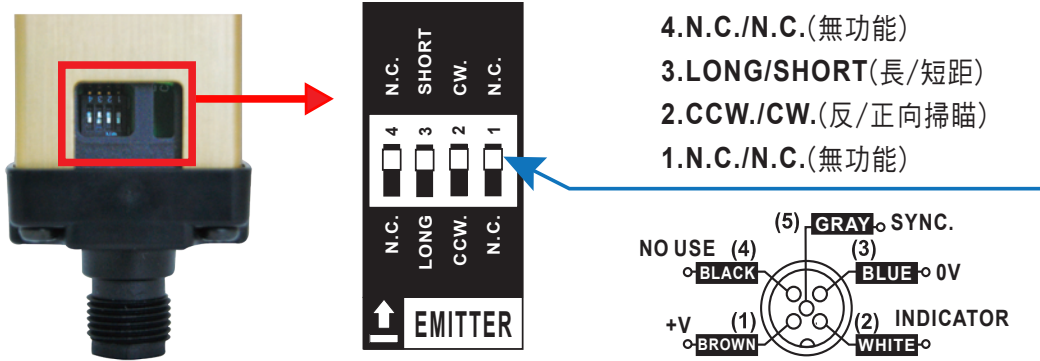

- Receiver / 接收

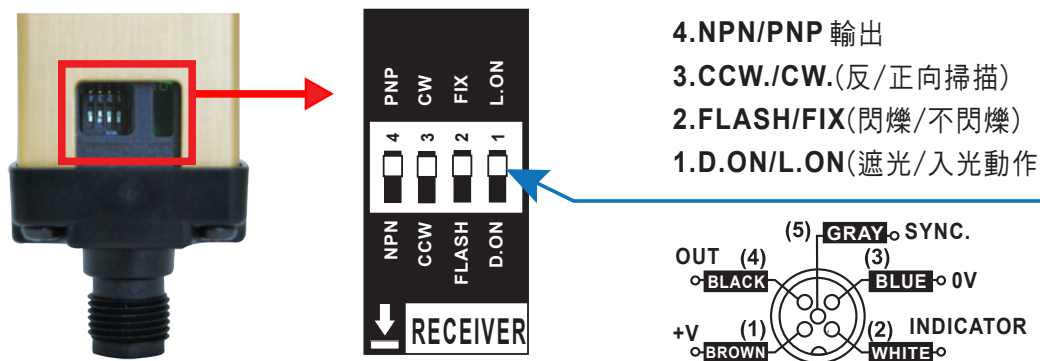

## Attention / 注意事項

### ⚠ Warning1 / 警告1

This product is not permitted to use with the machines which are not stopped electronically by electronic control. / 不可使用於無立即停止電子控制式的機器。

### ⚠ Warning2 / 警告2

Be sure to set some amount of safe distance between the sensor and dangerous point. / 在感應器及危險區域間，必須保持安全距離。

- Safe distance (D) formula. Min distance is 300mm. / 安全距離(D)公式。最短距離300mm。

$$D=2000 \times T+\alpha \quad (D \leq 500\text{mm})$$

$$D=1600 \times T+\alpha \quad (D > 500\text{mm})$$

$$D=\text{safe distance (mm)}$$

$$T=\text{response time (machine+sensor)}$$

$$\text{反應時間} = (\text{機器的反應時間} + \text{感應器的反應時間})$$

$$\alpha=90\text{mm}$$

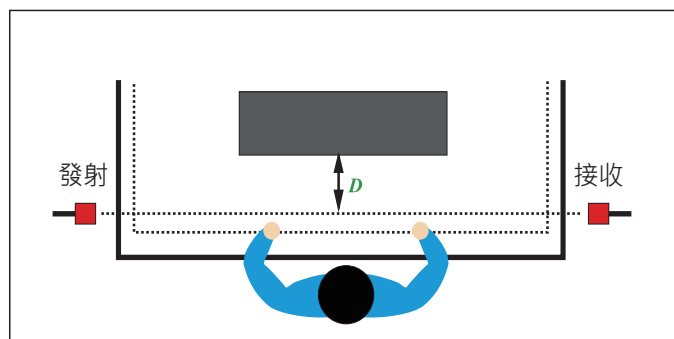

### ⚠ Warning3 / 警告3

Let worker keep working through the detecting range. / 在感測範圍內進行工作。

◆ Correct / 正確

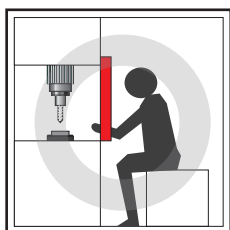

◆ Wrong / 錯誤

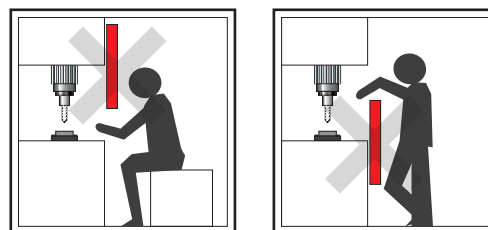

### ⚠ Warning4 / 警告4

When installing, please think of other reflecting object which may cause malfunction. / 安裝時，考慮是否有其它會導致機能故障的反射物。

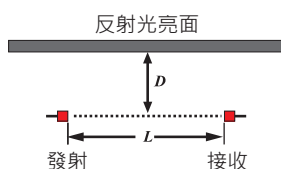
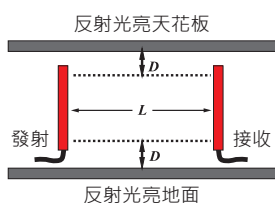

Acceptable installation distance / 可接受的安裝範圍

$$L=0.3\sim 2\text{M} \quad D \geq 300\text{mm}$$

$$L=0.6\sim 5\text{M} \quad D \geq 500\text{mm}$$



### Steps / 設定步驟

- Setting A: A-1: Put the object on position A; A-2: Press teach-in button 1 second; A-3 :LED twinkles once, setting A ok. / 設定檢測最遠距離：將被測物放置在A點，長按設定按鈕(約1s)，待LED燈閃爍1次，即A點設定完成。
- Setting B: B-1: Put the object on position B; B-2: Press teach-in button 1 second; B-3: LED twinkles three times, all setting completed. / 設定檢測最近距離：將被測物放置在B點，長按設定按鈕(約1s)，待LED燈閃爍3次，即B點設定完成；A點到B點的距離即為感應距離。

### Operation chart / 操作圖

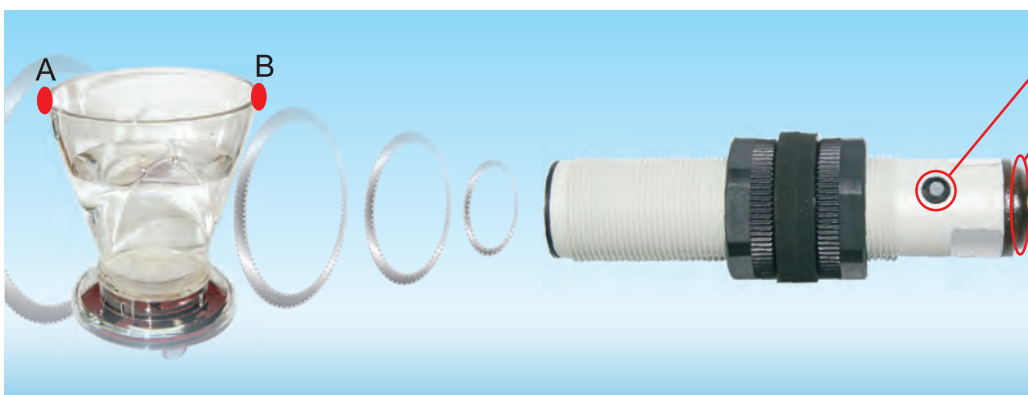

Teach-in button /  
設定按鍵

LED

A: The longest sensing distance /  
A: 檢測設定最遠距離

B: The nearest sensing distance  
( $\geq 15\text{cm}$ ) /  
B: 檢測設定最近距離  
檢測感應安全距離為15公分

## Characteristic / 特點：

- Working area adjusting by teach-in button suitable for all models for a fast reaction.  
/ 操作簡易，只需通過單一按鍵教導工作區(窗口設定)，產品能夠快速的進入工作狀態。
- Multifunction LED indicator: output state, teach-in function, NO/NC configuration.  
/ 多功能 LED 指示燈：LED 可顯示輸出狀態、設定狀態和 NO/NC 狀態等。
- Plastic housing, IP67 protection degree..  
/ 特殊塑料外殼，防水等級最高可達 IP67。
- Approvals: CE.  
/ 通過 CE 認證，品質可靠有保證。
- It's easy to detect transparent objects.  
/ 最適合於透明物體的檢測。



RU18

光電 / 光柵 / 超音波感測器

R5JM  
R3JK  
LK  
LRS  
PK3  
PKG3  
PK5  
PM6

PTQ18  
RMF  
MMF

SU07  
SU  
SU18  
SU30

SPR  
RX

OAP  
ASP

RU18

Output Method / 型號	Analogue output 0~10V	-	RU18-DU90-IK1	RU18-DU160-IK1	-
	Analogue output 0~10V	-	RU18-DU90-VK1	RU18-DU160-VK1	-
	NPN - NO /NC	-	RU18-DU90-NK1	RU18-DU160-NK1	-
	PNP - NO /NC	RU18-DU40PK1	RU18-DU90-PK1	RU18-DU160-PK1	RU18-DU200PK1
Maximum sensing distance / 最大檢測距離	400 mm	900 mm	1600 mm	2200 mm	
Sensing ranger(Sd) / 有效距離	100 ~ 400 mm	100 ~ 900 mm	150 ~ 1600 mm	200 ~ 2200 mm	
Beam Angle / 發射角度	±8°	±7°	±8°	±7° ±2°	
switching frequency / 頻率	10 Hz	4 Hz	2 Hz	1 Hz	
Repeat accuracy / 重複精度	0.5%				
Temperature range / 工作溫度	-20°C ~ +60°C	-10°C ~ +60°C	-20°C ~ +70°C		
Temperature compensation / 溫度補償	Yes				
Operating voltage / 工作電壓	DC 15 ~ 30 V				
Thermal drift / 熱量誤差	5%	< 5%	5%		
Ropple / 漣波因素	5%				
Leakage current / 漏電流	<10μA@VDC=30V				
Output current / 輸出電流	100 mA				
Minmum load resistance / 最小負載阻抗	3 KΩ	1 KΩ(analogue voltage output / 類比電壓輸出10V)		3 KΩ	
Adjustment set pint / 調整方式	Teach-in button / 按鍵設定				
Time delay before availability / 開機延遲時間	500 ms < 900 ms	300ms		500 ms < 900 ms	
Output Protection / 輸出保護	Polarity reversal; overvoltage pulses; short circuit / 極性逆接&過電壓&短路保護				
Protection degree / 防水等級	IP67				
Housing material / 外殼材質	PBT				
Active Head material / 振動器材質	Epoxy resin / 環氧樹脂				
Tightening torque / 扭力	1 Nm				
Weight / 重量	35 g				
Storage temperature / 保存溫度	-35°C~+70°C(without freezer / 無結霜、結冰)				

## Dimensions / 尺寸圖 (mm)

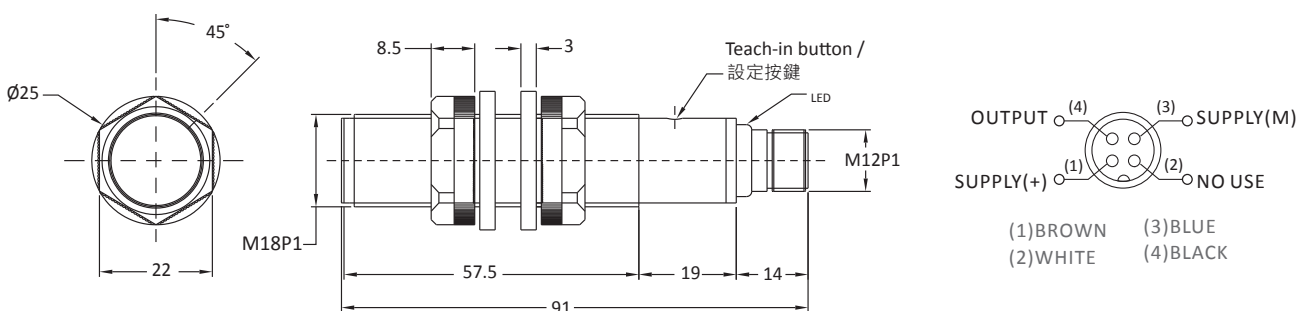

## Wiring diagrams / 接線圖

Digital output / 單一數位輸出模式

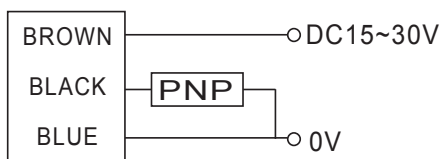

Analog output / 單一數位類比模式

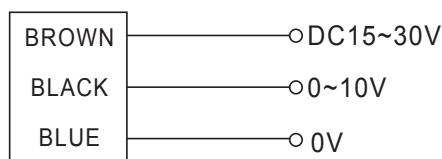

## Response diagram / 反應示意圖

### RU18-DU160

Parallel displacement  
平行位移

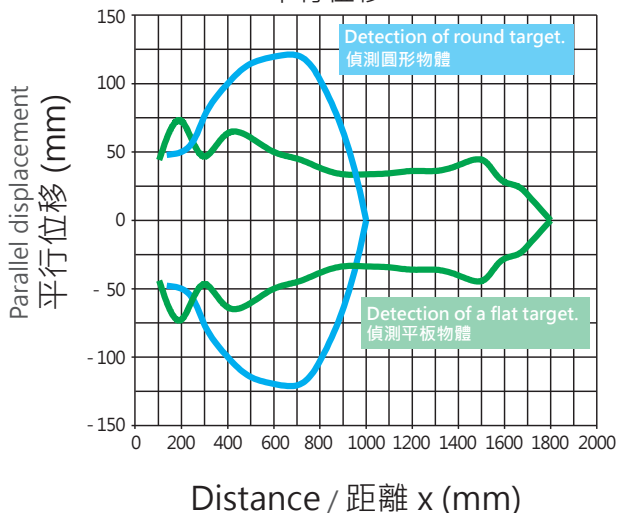

### RU18-DU90

Parallel displacement  
平行位移

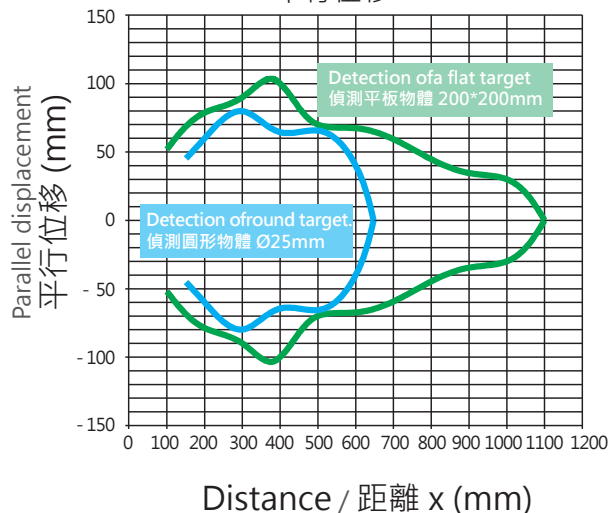

## Output chart / 輸出圖

Digital output / 單一數位輸出模式

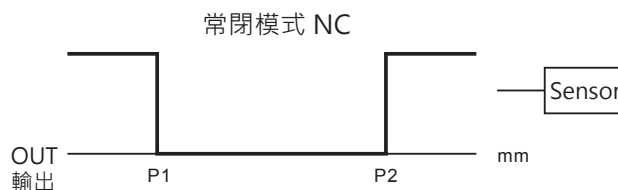
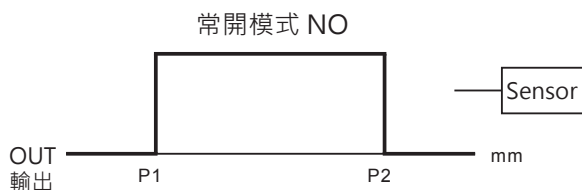

# Inductive / Capacitive Proximity Sensor

## 電感式/靜電容

Application  
應用例 79

Wiring diagrams  
接線圖 87

OPTIONS  
選型指南 88

Tubular Inductive Proximity Sensor  
圓管型近接開關

Ø3	89
Ø4	90
M5	91
Ø6	92
M8	93
M12	96
M18	102
M30	108

OPTIONS  
選型指南 117

Rectangular Inductive Proximity Sensor  
方型近接開關

JM/JMD	118
JN/JND	120
KND	122
PN	123
PND	126
RN	128
SN	130

Inductive Ring Sensor  
環型近接開關

SID	136
SIR	138
SIA	140

Capacitive Proximity Sensor  
靜電容式近接開關

KC	144
KCT	147
KCP	148

## I001 金屬工件檢測 / Detecting metal parts.

136頁

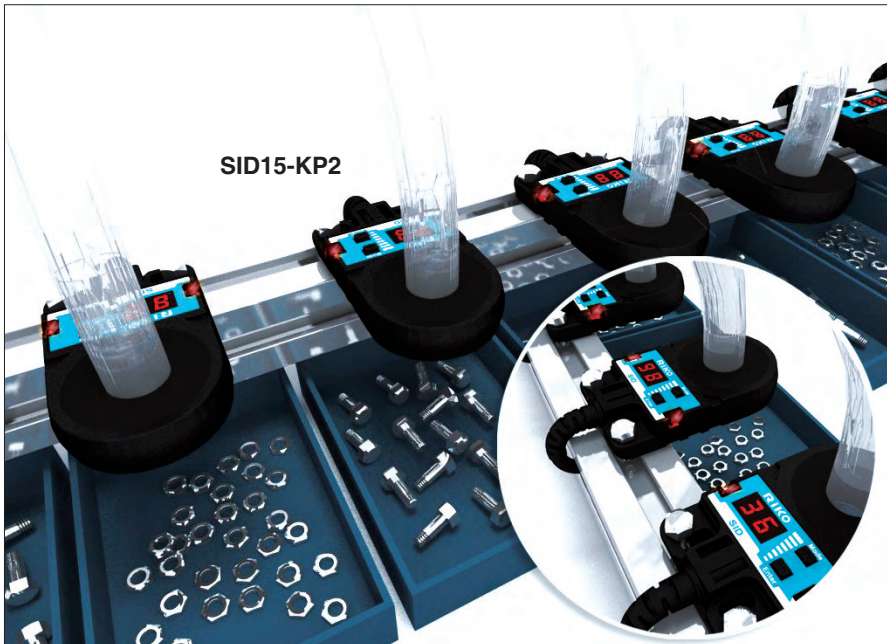

### 型號 / Model

SID15-KP2

### 檢知條件 / Application

2mm以上各式金屬工件，穿過檢出(銅、鐵、鋼及合金)...等皆可適用。  
2mm or more of various metal workpieces, through detection.

### 產品特性 / Features

數字顯示，0~999段感應強弱可調，四種延遲功能，0.1~9.9秒延遲時間可設定，依不同需求準確設定檢出條件。

Digital display, 0~999 sensing strength adjustment, four delay functions, depending on different needs set the detection conditions accurately.

光電 / 光柵 / 超音波感測器

電感式 / 靜電容近接開關

## I002 各式金屬板材定位 / Various metal plates positioning metal.

97頁

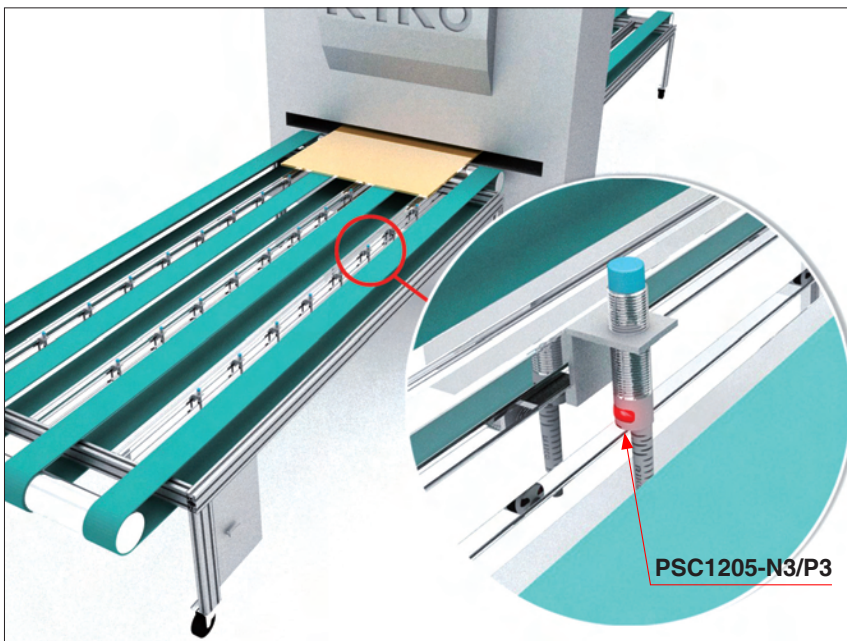

### 型號 / Model

PSC1205-N3/P3

### 檢知條件 / Application

800 x 1200 x 2mm 金屬板材，送料至多組並聯位置後檢出定位。  
800 x 1200 x 2mm sheet metal, send the position is detected after the parallel position is reached.

### 產品特性 / Features

M12 直徑近接，有6mm 加長感應距離，讓不同的金屬檢出更容易。加上高亮度動作指示燈，耐撓保護設計。

N3/P3 model : NPN N.O./N.C. & PNP N.O./N.C. 2-in-1 outputs.  
M12, 5mm sensing distance, high brightness action LED Light, anting-bending design.

其它

## I003 大型金屬閘門定位控制 / Sensing the height of a sluice gate.

125頁

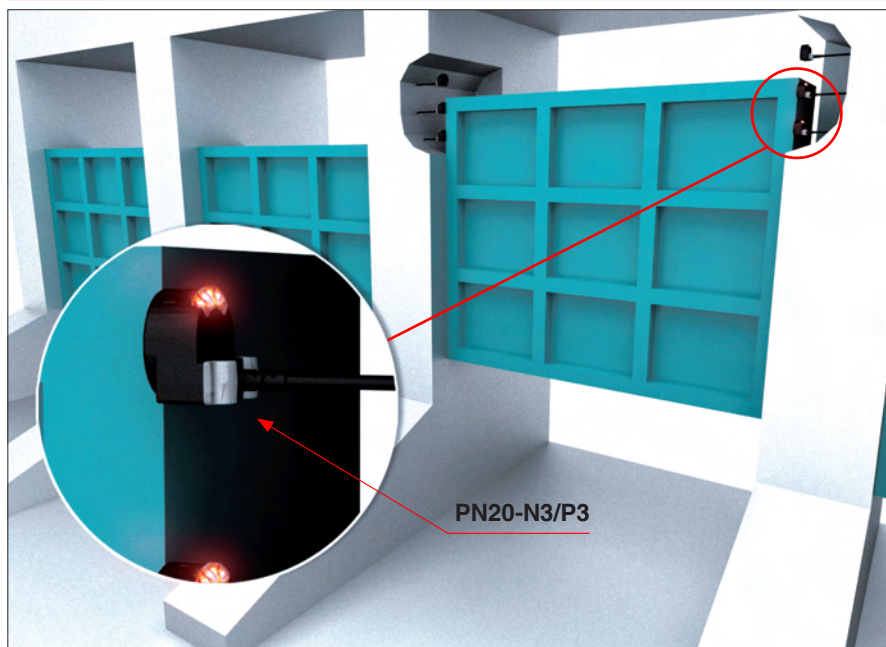

### 型號 / Model

PN20-N3/P3

### 檢知條件 / Application

5Mx15M金屬製閘門，開關門動作至多組串聯位置後檢出定位。

5Mx15M metal gate, door movement positioning is detected after making up to series positions.

### 產品特性 / Features

20mm檢距，相對一般傳統型體積減少近50%，IP67防水型近接開關，適用於戶外各式惡劣環境使用。

20mm sensing distance, IP67, for outdoor inferior environment use.

## I004 載車臺的機構定位 / Sensing the rotary plate of parking building.

125頁

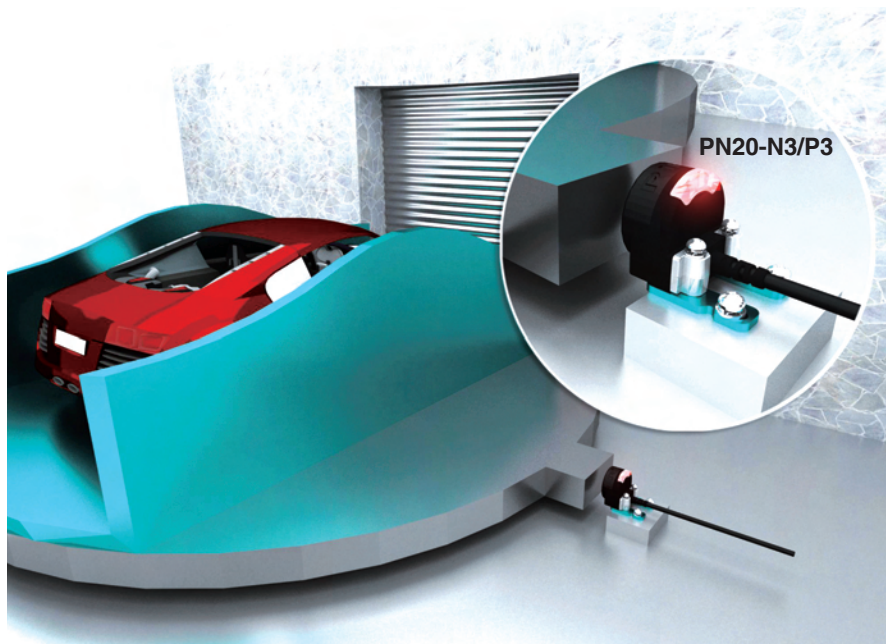

### 型號 / Model

PN20-N3/P3

### 檢知條件 / Application

50x60mm旋轉台金屬定位點檢出定位。

50x60mm rotating table metal positioning detect.

### 產品特性 / Features

利用新P3電路，來達到PNP、N.O、N.C的2 in 1 電氣特性，IP67防水型近接開關，耐用於各式惡劣環境。

N3/P3 model : NPN N.O./N.C. & PNP N.O./N.C. 2-in-1 outputs. IP67, for outdoor inferior environment use.

## I005 玻璃瓶液體充填 / Filling control.

145頁

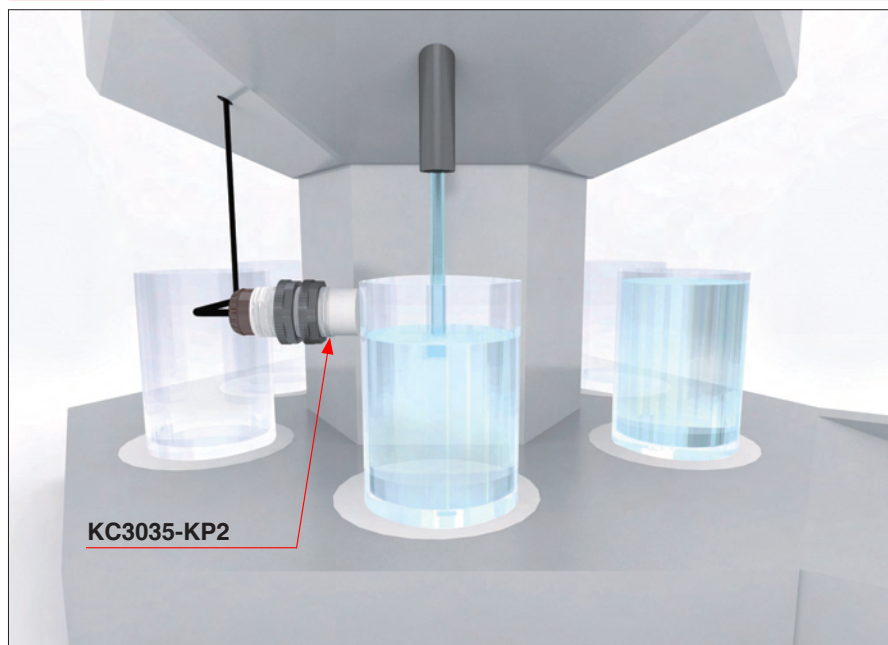

### 型號 / Model

KC3035-KP2

### 檢知條件 / Application

各式非金屬材質的瓶裝材料。  
Liquid Level Detection at non-metallic bottle.

### 產品特性 / Features

2~30mm檢距，靜電容感應式近接，可設定任何瓶中液體滿位檢出。

2~30mm sensing distance capacitive Proximity Sensor.

光電 / 光柵 / 超音波感測器

電感式 / 靜電容近接開關

## I006 馬達來回轉動定位 / Motor rotational positioning.

103 / 102頁

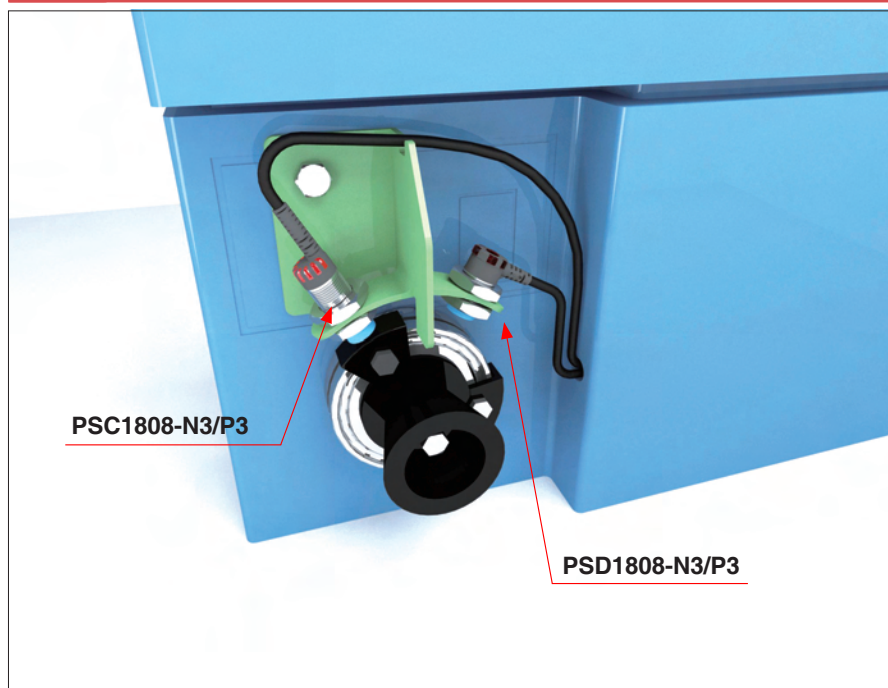

### 型號 / Model

PSC1808-N3/P3

PSD1808-N3/P3

### 檢知條件 / Application

18x18mm 感應鐵塊固定於轉動軸邊，來回動作定位檢出。

18x18mm iron block fixed to rotate axis edge, back and forth motion positioning detection.

### 產品特性 / Features

一體成型耐彎保護，IP67防水型近接開關，耐用於各式惡劣環境，創新90°包覆出線設計、270°可見動作指示燈號，方便安裝於狹小空間。

N3/P3 model: NPN N.O./N.C. & PNP N.O./N.C. 2-in-1 outputs. IP67, for outdoor Inferior environment use. anting-bending design, Innovative 90° design, easy Installed in a small space.

其它

## I007 大型機具流線架定位 / Positioning sensing.

127頁

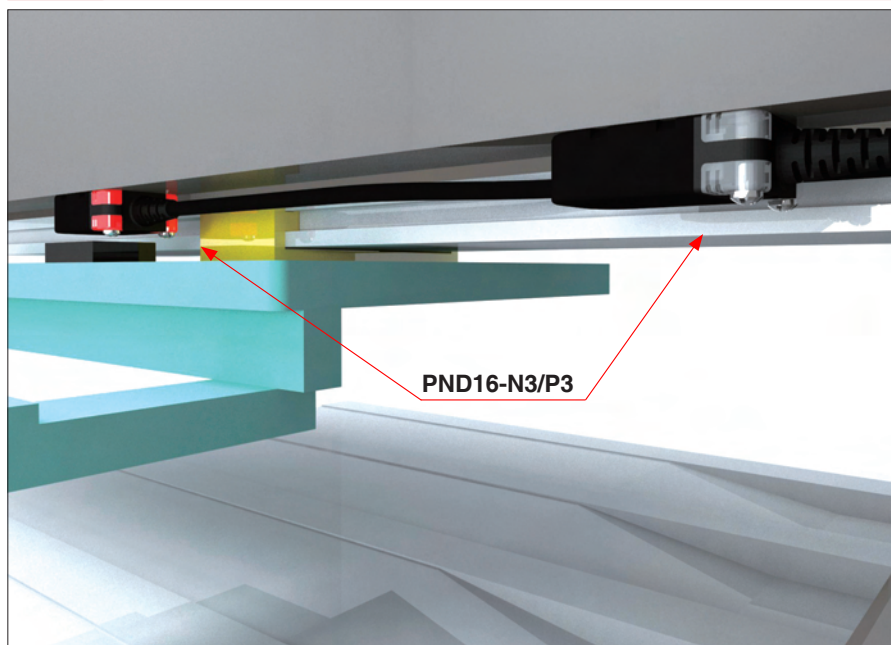

## 型號 / Model

PND16-N3/P3

## 檢知條件 / Application

30x30mm 感應鐵塊固定於定位點，可串聯感應更精準定位。  
30x30mm iron block fixed in positioning points can be connected in series for more precise positioning.

## 產品特性 / Features

16mm 檢距，扁型上方感應設計，適合安裝於狹長空間，一體成型耐彎保護，耐用於各式環境。  
16mm sensing distance, flat, front-side sensing, saving space.

Photo / Area Photo / Ultrasonic Sensor

Inductive / Capacitive Proximity Sensor

Others

## I008 滾珠螺桿推動定位 / Positioning sensing.

103頁

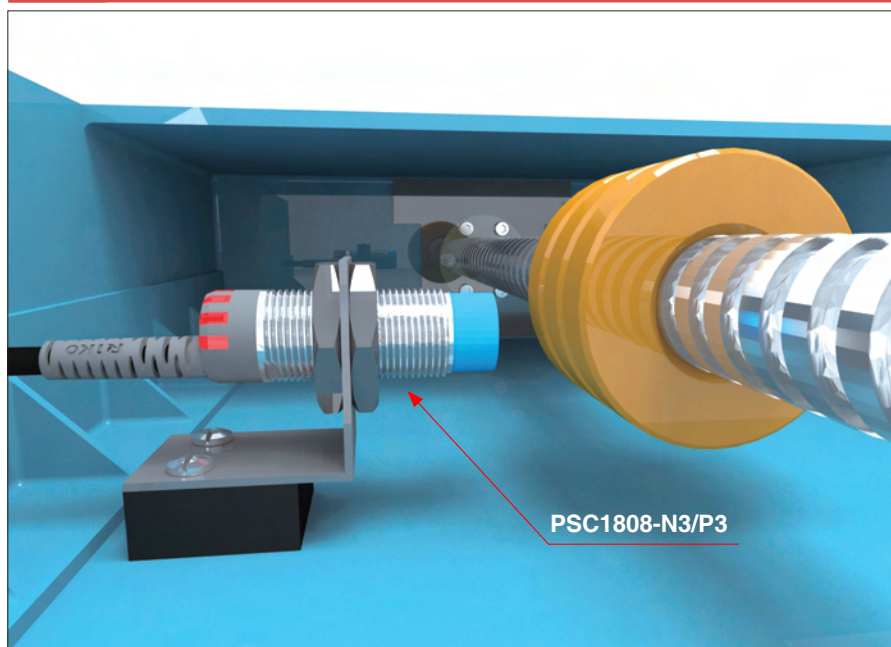

## 型號 / Model

PSC1808-N3/P3

## 檢知條件 / Application

18x18mm 滾珠環來回動作定位檢出。  
18x18mm ballscrew back and forth motion positioning detect.

## 產品特性 / Features

8mm非隔離型感應，270°可見動作指示燈號，一體成型耐彎保護，耐用於各式環境。

N3/P3 model : NPN N.O./N.C. & PNP N.O./N.C. 2-in-1 outputs.  
IP67, anti-bending design.

## I009 鐵塊成品堆疊滿料檢知 / Filling control.

102頁

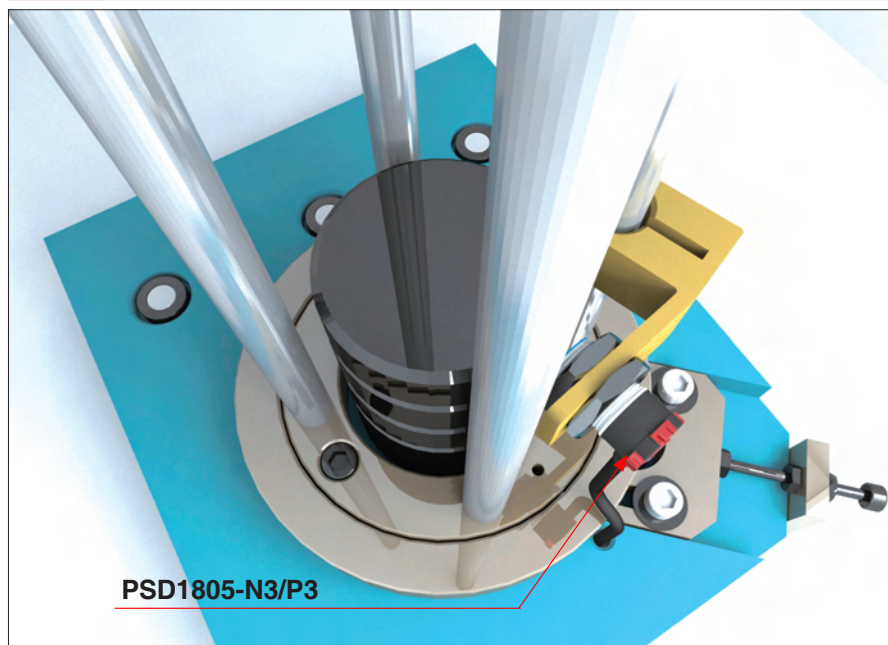

### 型號 / Model

PSD1805-N3/P3

### 檢知條件 / Application

18x18x1 mm 鐵塊堆疊至設定高度檢出。  
18 x 18 x 1 mm iron stacks to set height detection.

### 產品特性 / Features

5mm隔離型感應，不受四周環境影響，IP67防水設計，90°一體成型包覆出線設計，方便安裝於有限空間內，順著機體排線可達到一體化的美觀設計。

5mm shielded sensing distance, not impact by the iron environmental, IP67 model : NPN N.O./N.C. & PNP N.O./N.C. 2-in-1 outputs. IP67, Innovative 90° design, easy installed in a small space.

光電 / 光柵 / 超音波感測器

電感式 / 靜電容 / 接近開關

## I010 流線馬達轉動定位 / Positioning sensing.

126頁

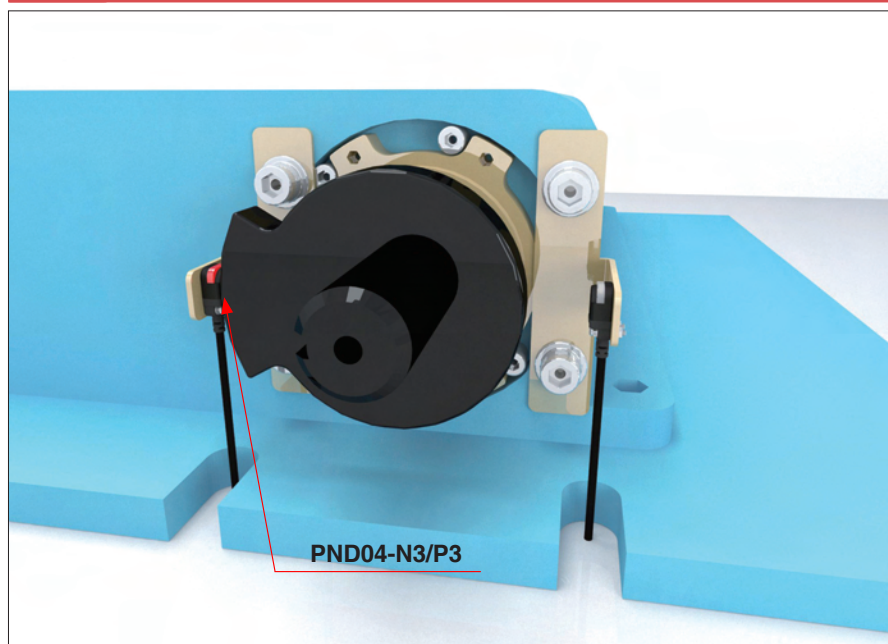

### 型號 / Model

PND04-N3/P3

### 檢知條件 / Application

18x18mm感應鐵塊固定於轉動軸邊，運轉動作定位檢出。  
18x18mm iron block fixed to rotate axis edge, back and forth motion positioning detection.

### 產品特性 / Features

4mm 檢距，僅10mm 厚度扁型上方感應，方便安裝於狹小空間及各式惡劣環境，IP67防水等級，一體成型耐彎保護。

4mm sensing distance, flat, front-side sensing, saving space. N3/P3 model : NPN N.O./N.C. & PNP N.O./N.C. 2-in-1 outputs.

其它

I011

102頁



機構定位

Positioning the moving-part.

P024

109頁

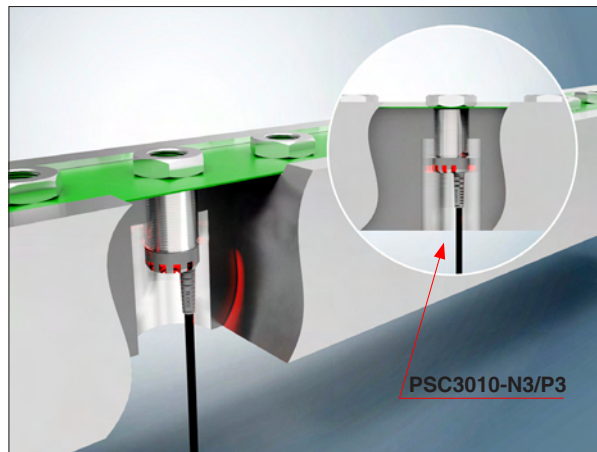

金屬零件通過檢測

For the metal parts detection.

P025

108頁

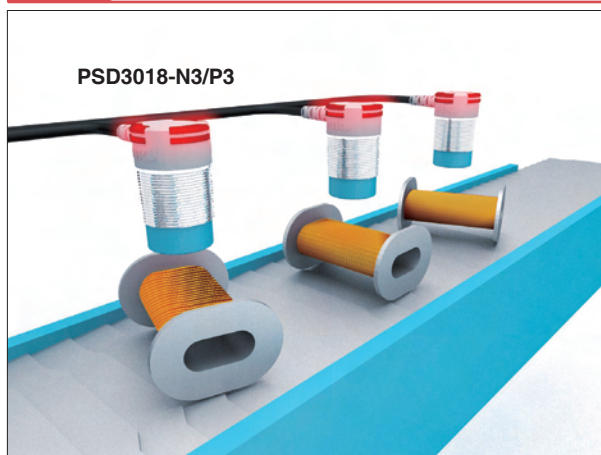

檢測銅繞組

Detecting of copper winding.

P026

124頁

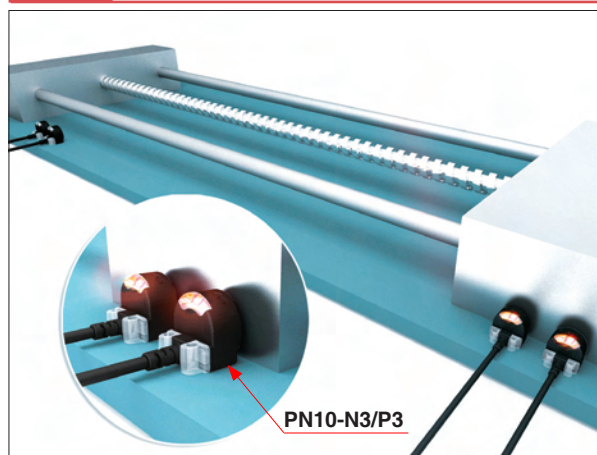

檢測工作台的位置

Detecting worktable positions.

P027

124頁

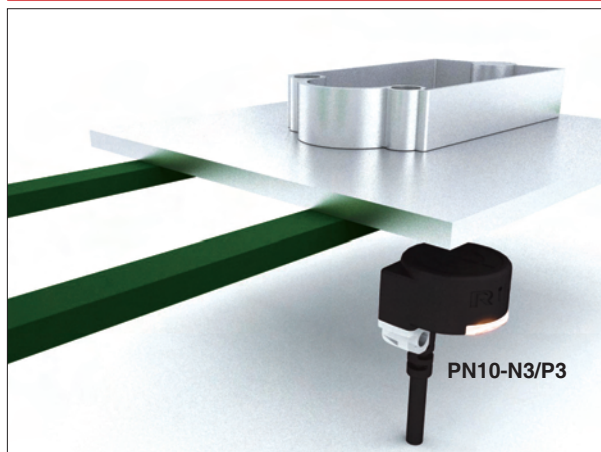

金屬板定位

Positioning metal pad.

P028

138頁



檢測金屬件

Detecting metal parts.

I017

145頁

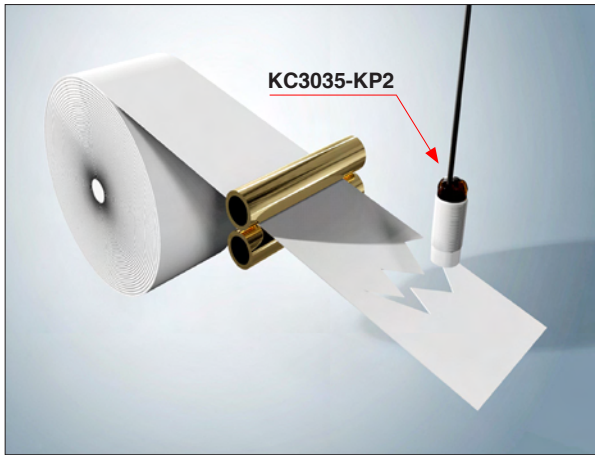

紙張破裂檢測

Detecting the breakage in reels of paper.

I018

149頁

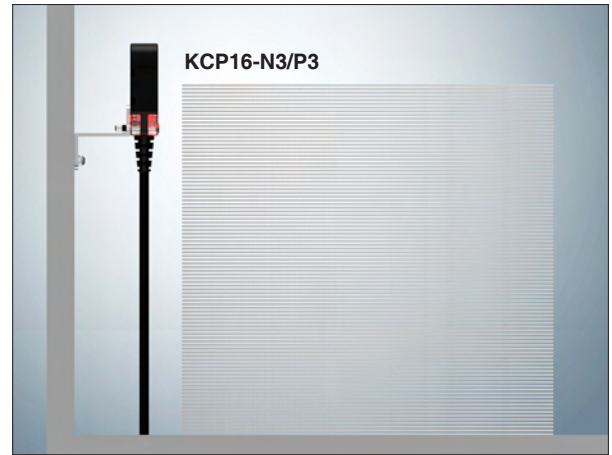

檢測紙堆高度

Detecting the height of a paper stack.

I019

102頁



檢測金屬工件位置

Detecting position of metal workpiece.

I020

144頁

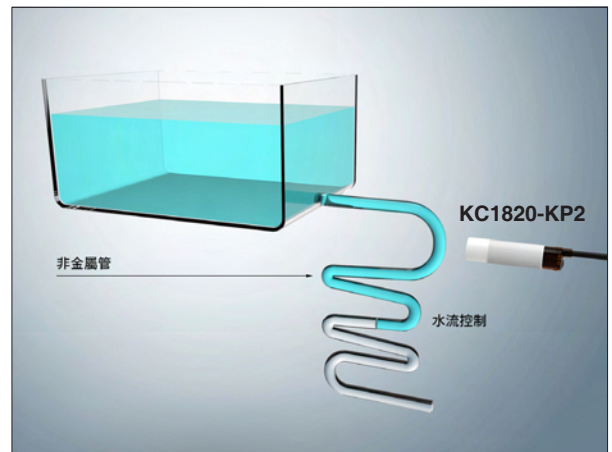

流量控制

Liquid flow control.

P021

123頁

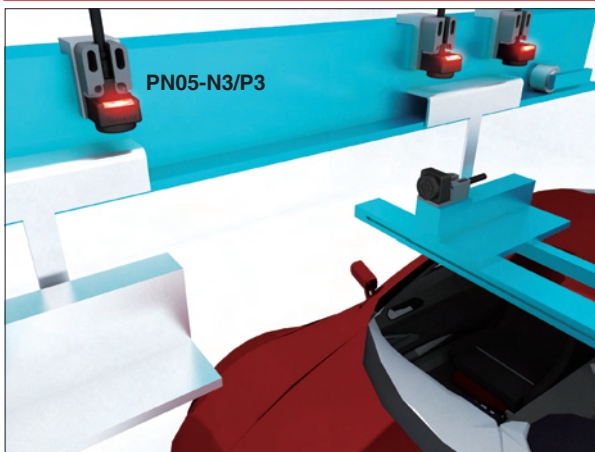

機構定位

Positioning the moving-part.

P022

145頁

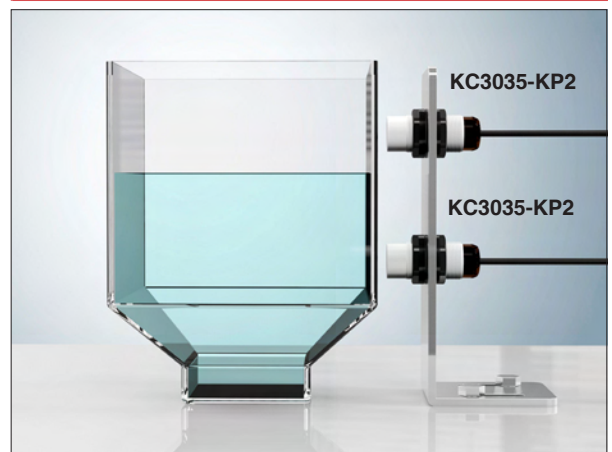

料位檢測

Level control for metal containers with plastic or glass windows.

光電／光柵／超音波感測器

電感式／靜電容近接開關

其它

I023

125頁

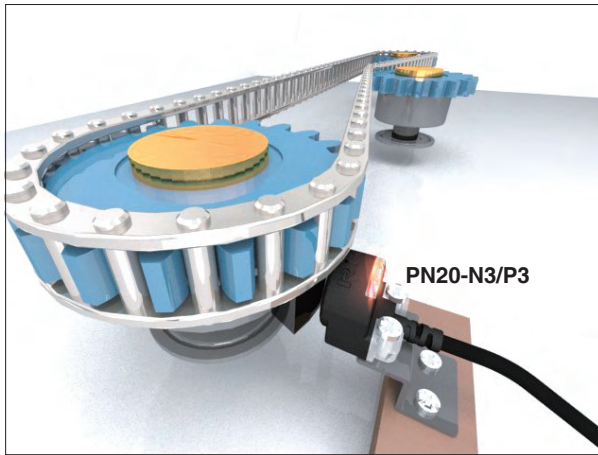

檢測齒輪圈數

Detecting mark on the rotary platform.

I024

124頁

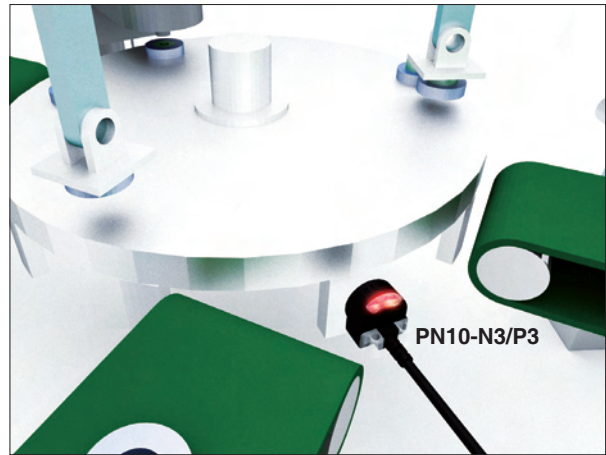

旋轉台上的標記位置

Detecting mark on the rotary platform.

I025

109頁

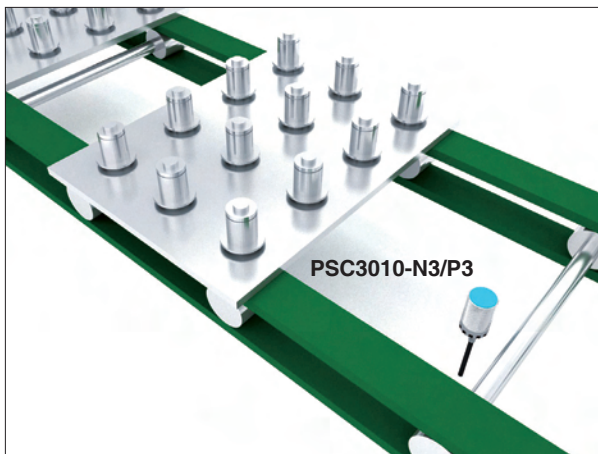

金屬載盤定位

Metal carrier positioning.

Photo / Area Photo /  
Ultrasonic Sensor

Inductive / Capacitive  
Proximity Sensor

Others

## NPN NO.NC. / PNP NO.NC. / NO+NC 輸出

### N3 系列

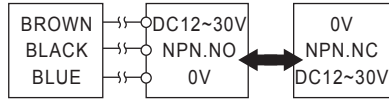

### N3B / N3B1 系列

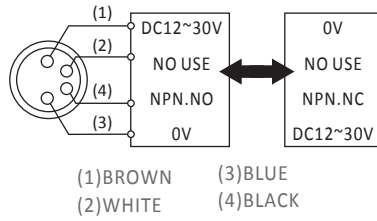

### N3K / N3M1 系列

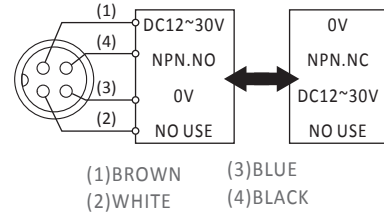

### P3 系列

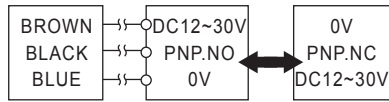

### P3B / P3B1 系列

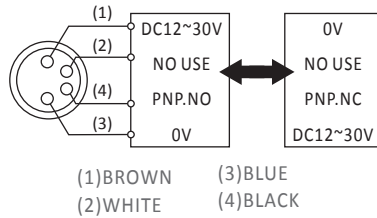

### P3K / P3M1 系列

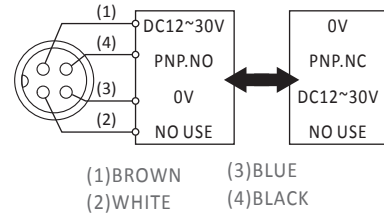

## 2-wires output / 二線式輸出

### C 系列

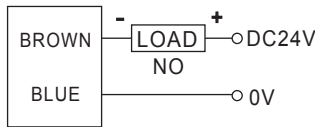

### C2 系列

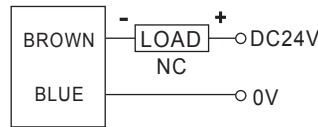

## Linear analog output / 線性輸出

### LA 系列

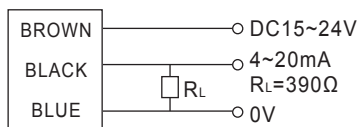

### LV 系列

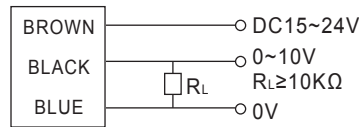

## 訂貨索引

HPD 08 01 - N D

Heat-resistant 90° right angle Inductive Proximity Sensor  
耐熱型90°出線圓管近接開關 **HPD**

Heat-resistant Inductive Proximity Sensor  
耐熱圓管型近接開關 **HPS**

Anti-Bending Inductive Proximity Sensor  
耐彎抗拉圓管型近接開關 **PSC**

Anti-Bending 90° right angle Inductive Proximity Sensor  
90°出線耐彎抗拉圓管型近接開關 **PSD**

Tubular type  
圓管型 **SC**

Tubular outside diameter  
圓管外徑 Ø3 **03**

Tubular outside diameter  
圓管外徑 Ø4 **04**

Tubular outside diameter  
圓管外徑 M5 **05**

Tubular outside diameter  
圓管外徑 Ø6.5 **06**

Tubular outside diameter  
圓管外徑 M8 **08**

Tubular outside diameter  
圓管外徑 M12 **12**

Tubular outside diameter  
圓管外徑 M18 **18**

Tubular outside diameter  
圓管外徑 M30 **30**

Sensing distance  
檢測距離 1mm **01**

Sensing distance  
檢測距離 2mm **02**

Sensing distance  
檢測距離 3mm **03**

Sensing distance  
檢測距離 4mm **04**

Sensing distance  
檢測距離 5mm **05**

Sensing distance  
檢測距離 6mm **06**

Sensing distance  
檢測距離 7mm **07**

Sensing distance  
檢測距離 8mm **08**

Sensing distance  
檢測距離 10mm **10**

Sensing distance  
檢測距離 12mm **12**

Sensing distance  
檢測距離 15mm **15**

Sensing distance  
檢測距離 18mm **18**

Sensing distance  
檢測距離 20mm **20**

Sensing distance  
檢測距離 25mm **25**

**B** M8 Pigtailed type  
M8出線式接頭型(15cm/4pin)

**B1** M8 plug-in connector type  
M8接頭型(4pin)

**K** M12 Pigtailed type  
M12出線式接頭型(15cm)

**M1** M12 Plug-in connector type(Metal)  
M12接頭型(金屬)

Pre-wired 2M model  
出線式 2M

**N3** Output NPN N.O. / N.C.  
輸出 NPN N.O. / N.C.

**P3** Output PNP N.O. / N.C.  
輸出 PNP N.O. / N.C.

**KP2** NPN.NO/NC & PNP.NC/NO  
All in one 四合一

**LA** Linear 4~20 mA  
模擬量 4~20 mA

**LV** Linear 0~10V  
模擬量 0~10V

**C** 2-Wires(N.O.)  
2-線(N.O.)

**C2** 2-Wires(N.C.)  
2-線(N.C.)

※部分機種提供 N / P / N2 / P2

# Ø3 圓管型近接開關

## Tubular Inductive Proximity Sensor

### Characteristic / 特點：

- 迷你精巧 3mm x 26mm  
/ Miniature Dimensions Ø3 x 26mm.
- 放大器內藏型，三條線直接接線  
/ Integrated Amplifier, Three wires connection straight out.
- 本體不鏽鋼304，出線PUR軟線  
/ Stainless Housing, flexible cable(PUR).
- 短路，逆接保護  
/ Short Circuit/Reverse Polarity Protected.
- IP67防水等級  
/ Protection rating IP67.



Model / 型號	NPN N.O.	SC0301-N
	NPN N.C.	SC0301-N2
	PNP N.O.	SC0301-P
	PNP N.C.	SC0301-P2
Sensing distance / 檢出距離		0.6 mm ±10%
Standard sensing object / 標準檢測物		Iron / 鐵 5x5x1 mm
Sensing type / 檢出方式		Shielded / 隔離型
Response time / 反應頻率		2000 Hz
Operating voltage / 工作電壓		DC10~30 V
Current consumption / 消耗電流		< 8 mA
Load current / 負載電流		120 mA
Voltage drop / 殘餘電壓		<1.5 V @ 200 mA
Operating temperature / 工作溫度		-20 °C...+70 °C
Protection degree / 防水等級		IP67
Wiring method / 出線方式		Ø2.6 x 2M / 3 wires
<b>Wiring diagrams / 接線圖</b>		
<b>-N</b>		
<b>-P</b>		

Ø3

電感式一靜電容近接開關

Ø3  
Ø4  
M5  
Ø6  
M8  
M12  
M18  
M30

JM  
JN  
KND  
PN  
PND  
RN  
SN

SID  
SIR  
SIA

KC  
KCT  
KCP

## Characteristic / 特點：

- 迷你精巧 4mm x 26mm  
/ Miniature Dimensions Ø4 x 26mm.
- 放大器內藏型，三條線直接接線  
/ Integrated Amplifier, Three wires connection straight out.
- 本體不鏽鋼304，出線PUR軟線  
/ Stainless Housing, flexible cable(PUR).
- 短路，逆接保護  
/ Short Circuit/Reverse Polarity Protected.
- IP67防水等級  
/ Protection rating IP67.



Model / 型號	NPN N.O.	SC0401-N
	NPN N.C.	SC0401-N2
	PNP N.O.	SC0401-P
	PNP N.C.	SC0401-P2
Sensing distance / 檢出距離		0.8 mm ±10%
Secure sensing distance / 建議距離		0.6 mm
Standard sensing object / 標準檢測物		Iron / 鐵 4 x 4 x 1mm
Sensing type / 檢出方式		Shielded / 隔離型
Description / 外型		Standard Ø4 / 標準Ø4
Hysteresis / 遲滯		≤ 10 % of sensing distance
Response time / 反應頻率		2000 Hz
Operating voltage / 工作電壓		DC10 ~ 30 V
Current consumption / 消耗電流		≤ 10 mA no-load
Load current / 負載電流		200 mA Max.
Residual voltage / 殘餘電壓		≤ DC 1.5V (200mA)
Voltage withstandability / 絕緣耐壓		AC1000V 60Hz for 60 Sec.
Operating temperature / 工作溫度		-20°C ~ + 70°C
Protection degree / 防水等級		IP 67
Wiring method / 出線方式		Ø3.1 x 2M / 3 wires
Weight / 重量		26g

### Wiring diagrams / 接線圖

-N

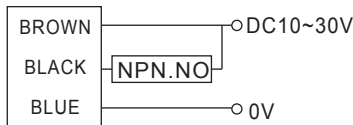

-P

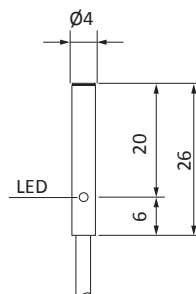
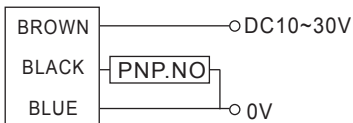

Ø4

電感式 - 靜電容近接開關

Ø3  
Ø4  
M5  
Ø6  
M8  
M12  
M18  
M30

JM  
JN  
KND  
PN  
PND  
RN  
SN

SID  
SIR  
SIA

KC  
KCT  
KCP

# M5 圓管型近接開關

## Tubular Inductive Proximity Sensor

### Characteristic / 特點：

- 迷你精巧 5mm x 26mm  
/ Miniature Dimensions M5 x 26mm.
- 放大器內藏型，三條線直接接線  
/ Integrated Amplifier, Three wires connection straight out.
- 本體不鏽鋼304，出線PUR軟線  
/ Stainless Housing, flexible cable(PUR).
- 短路，逆接保護  
/ Short Circuit/Reverse Polarity Protected.
- IP67防水等級  
/ Protection rating IP67.



Model / 型號	NPN N.O.	SC0501-N
	NPN N.C.	SC0501-N2
	PNP N.O.	SC0501-P
	PNP N.C.	SC0501-P2
Sensing distance / 檢出距離	0.8 mm ±10%	
Secure sensing distance / 建議距離	0.6 mm	
Standard sensing object / 標準檢測物	Iron / 鐵 5 x 5 x 1mm	
Sensing type / 檢出方式	Shielded / 隔離型	
Description / 外型	Standard M5 / 標準M5	
Hysteresis / 遲滯	≤ 10 % of sensing distance	
Response time / 反應頻率	2000 Hz	
Operating voltage / 工作電壓	DC10 ~ 30 V	
Current consumption / 消耗電流	≤ 10 mA no-load	
Load current / 負載電流	200 mA Max.	
Residual voltage / 殘餘電壓	≤ DC 1.5V (200mA)	
Voltage withstandability / 絕緣耐壓	AC1000V 60Hz for 60 Sec.	
Operating temperature / 工作溫度	-20°C ~ + 70°C	
Protection degree / 防水等級	IP 67	
Wiring method / 出線方式	Ø3.1 x 2M / 3 wires	
Weight / 重量	26g	

### Wiring diagrams / 接線圖

-N

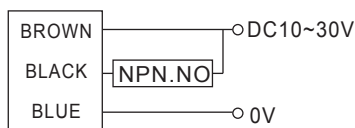

-P

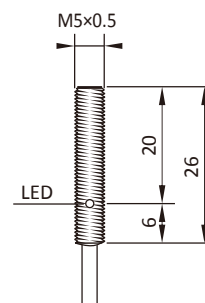
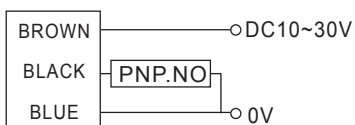

M5

電感式  
—  
靜電容  
近接開關

Ø3  
Ø4  
M5  
Ø6  
M8  
M12  
M18  
M30

JM  
JN  
KND  
PN  
PND  
RN  
SN

SID  
SIR  
SIA

KC  
KCT  
KCP

## Characteristic / 特點 :

- 迷你精巧 6.5mm x 30mm  
/ Miniature Dimensions Ø6.5 x 30mm.
- 放大器內藏型，三條線直接接線  
/ Integrated Amplifier, Three wires connection straight out.
- 本體不鏽鋼304，出線PVC軟線  
/ Stainless Housing, flexible cable(PVC).
- 短路，逆接保護  
/ Short Circuit/Reverse Polarity Protected.
- IP67防水等級  
/ Protection rating IP67.



Model / 型號	NPN N.O.	SC0601-N	SC0602-N
	PNP N.O.	SC0601-P	SC0602-P
Sensing distance / 檢出距離	1 mm ±10%		2 mm ±10%
Secure sensing distance / 建議距離	0.8 mm		1.6 mm
Standard sensing object / 標準檢測物	Iron / 鐵 6x6x1 mm		
Sensing type / 檢出方式	Shielded / 隔離型		Unshielded / 非隔離型
Description / 外型	Standard Ø6.5 / 標準Ø6.5		
Hysteresis / 遲滯	≤ 20 % of sensing distance		
Response time / 反應頻率	2000 Hz		
Operating voltage / 工作電壓	DC10 ~ 30 V		
Current consumption / 消耗電流	≤ 10 mA no-load		
Load current / 負載電流	200 mA Max.		
Residual voltage / 殘餘電壓	≤ DC 1.8V (200mA)		
Voltage withstandability / 絕緣耐壓	AC1000V 60Hz for 60 Sec.		
Operating temperature / 工作溫度	-20°C ~ + 70°C		
Protection degree / 防水等級	IP 67		
Wiring method / 出線方式	Ø3.1 x 2M / 3 wires		
Weight / 重量	32g		

### Wiring diagrams / 接線圖

-N

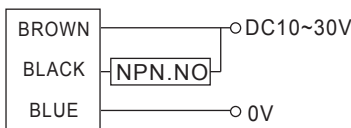

-P

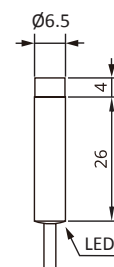
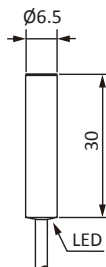
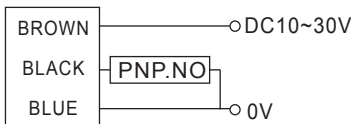

## M8 耐彎抗拉圓管型近接開關

### Characteristic / 特點：

- 90 degree wiring saving space.  
/ 專利90度出線設計，節省空間。
- Anti-bending connection design.  
/ 獨特的包覆設計，耐彎保護佳。
- N3/P3 model : NPN N.O./N.C. & PNP N.O./N.C. 2-in-1 outputs.  
/N3/P3電路：NPN N.O./N.C. & PNP N.O./N.C. 2合1輸出。
- Surge suppressor and overload protection.  
/ 突波吸收，負載保護。

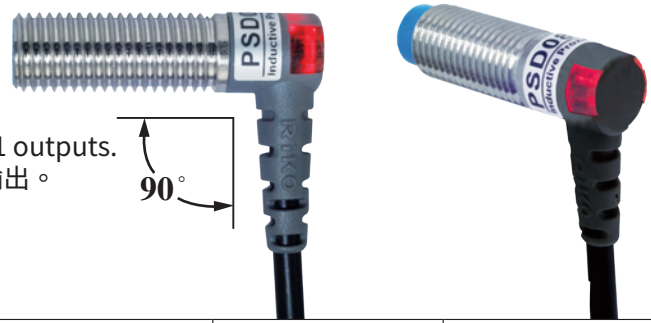

Model / 型號	NPN N.O. / N.C.	PSD0801-N3	PSD0801-N3B	PSD0803-N3	PSD0803-N3B
	PNP N.O. / N.C.	PSD0801-P3	PSD0801-P3B	PSD0803-P3	PSD0803-P3B
	DC 2 線式 N.O.	PSD0801-C	-	PSD0802-C	-
	DC 2 線式 N.C.	PSD0801-C2	-	PSD0802-C2	-
Sensing distance / 檢出距離	1 mm ±10%			3 mm / 2mm ±10%	
Secure sensing distance / 建議距離	0 ~ 0.8 mm			0 ~ 2.4 mm / 0 ~ 1.6mm	
Standard sensing object / 標準檢測物	Iron / 鐵 8 × 8 × 1 mm				
Sensing type / 檢出方式	Shielded / 隔離型			Unshielded / 非隔離型	
Description / 外型	Standard M8 / 標準M8				
Hysteresis / 遲滯	≤ 10 % of sensing distance / 檢測距離的 10 % 以下				
Response time / 反應頻率	600 Hz				
Operating voltage / 工作電壓	DC12 ~ 30 V / DC24 V ±10%				
Current consumption / 消耗電流	≤ 8 mA no-load (Not for C / C2)				
Load current / 負載電流	100 mA Max. at DC 24V				
Residual voltage / 殘餘電壓	≤ DC 2V / ≤ DC 7V				
Insulation resistance / 隔離阻抗	20MΩ min. (DC500V)				
Voltage withstandability / 絕緣耐壓	AC1000V 60Hz for 60 Sec.				
Operating temperature / 工作溫度	-20°C ~ + 60°C				
Protection degree / 防水等級	IP 67				
Option / 選購配件	M84R-2M-PVC / M84RL-2M PVC				
Wiring method / 出線方式	N3/P3: Ø3 x 2M / 3 wires C/C2: Ø3 x 2M / 2 wires	M8 pigtailed type / M8 出線式接頭型	N3/P3: Ø3 x 2M / 3 wires C/C2: Ø3 x 2M / 2 wires	M8 pigtailed type / M8 出線式接頭型	
Weight / 重量	28g	12g	28g	12g	
<b>Wiring diagrams / 接線圖</b>					
<b>-N3</b>					
<b>-P3B</b>					
<b>-C</b>					

M8

電感式  
靜電容  
近接開關

Ø3  
Ø4  
Ø5  
Ø6  
M8  
M12  
M18  
M30

JM  
JN  
KND  
PN  
PND  
RN  
SN

SID  
SIR  
SIA

KC  
KCT  
KCP

## Characteristic / 特點：

- Special line-out design for bending resistance and tensile. It will upgrade the durability and life.  
/ 獨特的出線包覆設計，抗拉、耐彎曲，提升耐用度和壽命。
- The IP67 rating is designed to the effective waterproof.  
/ 保護結構達到IP67的規格，能有效的防水。
- N3/P3 model : NPN N.O./N.C. & PNP N.O./N.C. 2-in-1 outputs.  
/ N3/P3電路：NPN N.O./N.C. & PNP N.O./N.C. 2合1輸出。
- Surge suppressor and overload protection .  
/ 突波吸收，負載保護。



Model / 型號	NPN N.O. / N.C.	PSC0801-N3	PSC0801-N3B	PSC0802-N3	PSC0802-N3B
	PNP N.O. / N.C.	PSC0801-P3	PSC0801-P3B	PSC0802-P3	PSC0802-P3B
	DC 2 線式 N.O.	PSC0801-C	-	PSC0802-C	-
	DC 2 線式 N.C.	PSC0801-C2	-	PSC0802-C2	-
Sensing distance / 檢出距離	1 mm ±10%			2 mm ±10%	
Secure sensing distance / 建議距離	0 ~ 0.8 mm			0 ~ 1.6 mm	
Standard sensing object / 標準檢測物	Iron / 鐵 8 × 8 × 1mm				
Sensing type / 檢出方式	Shielded / 隔離型			Unshielded / 非隔離型	
Description / 外型	Standard M8 / 標準M8				
Hysteresis / 遲滯	≤10 % of sensing distance / 檢測距離的 10 % 以下				
Response time / 反應頻率	500 Hz				
Operating voltage / 工作電壓	DC12 ~ 30 V / DC24 V ±10%				
Current consumption / 消耗電流	≤ 8 mA no-load / (Not for C / C2)				
Load current / 負載電流	100 mA Max. at DC 24V				
Residual voltage / 殘餘電壓	≤ DC 2V / ≤ DC 7V				
Insulation resistance / 隔離阻抗	20MΩ min. (DC500V)				
Voltage withstandability / 絕緣耐壓	AC1000V 60Hz for 60 Sec.				
Operating temperature / 工作溫度	-20°C ~ +60°C				
Protection degree / 防水等級	IP 67				
Option / 選購配件	M84R-2M-PVC / M84RL-2M PVC				
Wiring method / 出線方式	N3/P3: Ø3 x 2M / 3 wires C/C2 : Ø3 x 2M / 2 wires	M8 pigtailed type / M8 出線式接頭型	N3 / P3: Ø3 x 2M / 3 wires C/C2 : Ø3 x 2M / 2 wires	M8 pigtailed type / M8 出線式接頭型	
Weight / 重量	30g	12g	30g	12g	
<b>Wiring diagrams / 接線圖</b>					
<b>-N3</b>					
<b>-P3B</b>					

M8

電感式 - 靜電容近接開關

Ø3  
Ø4  
M5  
Ø6  
M8  
M12  
M18  
M30

JM  
JN  
KND  
PN  
PND  
RN  
SN

SID  
SIR  
SIA

KC  
KCT  
KCP

# M8 圓管型近接開關

# Tubular Inductive Proximity Sensor

## Characteristic / 特點：

- Large LED indicator, check the operation clerly.  
/ 專利大面積動作燈，可清晰了解感測器的動作。
- M8 4pin connector model available.  
/ M8 4pin接頭外型，同步於歐、美、日。
- N3/P3 model : NPN N.O./N.C. & PNP N.O./N.C. 2-in-1 outputs.  
/ N3/P3電路：NPN N.O./N.C. & PNP N.O./N.C. 2合1輸出。
- Surge suppressor and overload protection .  
/ 突波吸收，負載保護。

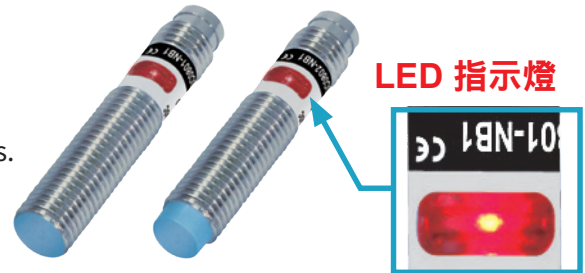

Model / 型號	NPN N.O. / N.C.	<b>PSC0801-N3B1</b>	<b>PSC0802-N3B1</b>
	PNP N.O. / N.C.	<b>PSC0801-P3B1</b>	<b>PSC0802-P3B1</b>
Sensing distance / 檢出距離	1 mm ±10%		2 mm ±10%
Secure sensing distance / 建議距離	0 ~ 0.8 mm		0 ~ 1.6 mm
Standard sensing object / 標準檢測物	Iron / 鐵 8 × 8 × 1mm		
Sensing type / 檢出方式	Shielded / 隔離型		Unshielded / 非隔離型
Description / 外型	Standard M8 / 標準M8		
Hysteresis / 遲滯	≤ 10 % of sensing distance / 檢測距離的 10 %以下		
Response time / 反應頻率	600 Hz		
Operating voltage / 工作電壓	DC12 ~ 30 V		
Current consumption / 消耗電流	≤ 8 mA no-load		
Load current / 負載電流	100 mA Max. at DC 24V		
Residual voltage / 殘餘電壓	≤ DC 2V		
Insulation resistance / 隔離阻抗	20MΩ min. (DC500V)		
Voltage withstandability / 絕緣耐壓	AC1000V 60Hz for 60 Sec.		
Operating temperature / 工作溫度	-20°C ~ + 60°C		
Protection degree / 防水等級	IP 66		
Option / 選購配件	M84R-2M-PVC / M84RL-2M PVC		
Wiring method / 出線方式	M8 pigtailed type / M8-4Pin 出線式接頭型		
Weight / 重量	6g		
<b>Wiring diagrams / 接線圖</b>			
<b>-N3B1</b>			
<p>(1) BROWN (3) BLUE (2) WHITE (4) BLACK</p>			
<b>-P3B1</b>			
<p>(1) BROWN (3) BLUE (2) WHITE (4) BLACK</p>			

M8

電感式一靜電容近接開關

Ø3  
Ø4  
Ø5  
Ø6  
M8  
M12  
M18  
M30

JM  
JN  
KND  
PN  
PND  
RN  
SN

SID  
SIR  
SIA

KC  
KCT  
KCP

## Characteristic / 特點：

- 90 degree wiring saving space.  
/ 專利90度出線設計，節省空間。
- Anti-bending connection design.  
/ 獨特的包覆設計，耐彎保護佳。
- N3/P3 model : NPN N.O./N.C. & PNP N.O./N.C. 2-in-1 outputs.  
/ N3/P3電路：NPN N.O./N.C. & PNP N.O./N.C. 2合1輸出。
- Surge suppressor and overload protection.  
/ 突波吸收，負載保護。

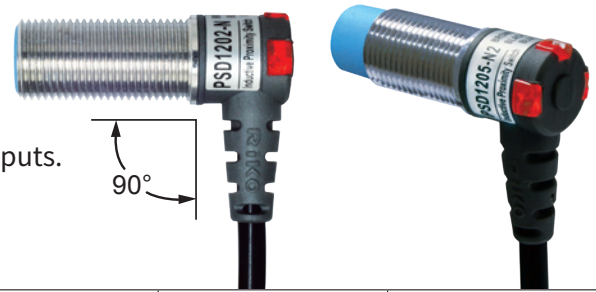

M12

電感式—靜電容近接開關

Ø3  
Ø4  
M5  
Ø6  
M8

M12  
M18  
M30

JM  
JN  
KND  
PN  
PND  
RN  
SN

SID  
SIR  
SIA

KC  
KCT  
KCP

Model / 型號	NPN N.O. / N.C.	PSD1202-N3	PSD1202-N3B	PSD1205-N3	PSD1205-N3B
	PNP N.O. / N.C.	PSD1202-P3	PSD1202-P3B	PSD1205-P3	PSD1205-P3B
	DC 2 線式 N.O.	PSD1202-C	-	PSD1205-C	-
	DC 2 線式 N.C.	PSD1202-C2	-	PSD1205-C2	-
Sensing distance / 檢出距離	2 mm ±10%			5 mm ±10%	
Secure sensing distance / 建議距離	0 ~ 1.6 mm			0 ~ 4.0 mm	
Standard sensing object / 標準檢測物	Iron / 鐵 12 × 12 × 1mm				
Sensing type / 檢出方式	Shielded / 隔離型			Unshielded / 非隔離型	
Description / 外型	Standard M12 / 標準M12				
Hysteresis / 遲滯	≤ 10 % of sensing distance / 檢測距離的 10 % 以下				
Response time / 反應頻率	500 Hz				
Operating voltage / 工作電壓	DC12 ~ 30 V / DC 24 V ± 10%				
Current consumption / 消耗電流	≤ 14 mA no-load (Not for C / C2)				
Load current / 負載電流	100 mA Max. at DC 24V				
Residual voltage / 殘餘電壓	≤ DC 2V / ≤ DC 7V				
Insulation resistance / 隔離阻抗	20MΩ min. (DC500V)				
Voltage withstandability / 絕緣耐壓	AC1000V 60Hz for 60 Sec.				
Operating temperature / 工作溫度	-20°C ~ + 60°C				
Protection degree / 防水等級	IP 67				
Option / 選購配件	M84R-2M-PVC / M84RL-2M PVC				
Wiring method / 出線方式	N3/P3: Ø4.2x2M/3wires C/C2: Ø4.2 x 2M/2 wires	M8 pigtailed type / M8 出線式接頭型	N3/P3: Ø4.2x2M/3wires C/C2: Ø4.2 x 2M/2 wires	M8 pigtailed type / M8 出線式接頭型	
Weight / 重量	60g	20g	56g	16g	
<b>Wiring diagrams / 接線圖</b>					
<b>-N3</b>					
<b>-P3B</b>					
<p>(1) BROWN (3) BLUE (2) WHITE (4) BLACK</p>					

# M12 耐彎抗拉圓管型近接開關

# Tubular Inductive Proximity Sensor

## Characteristic / 特點：

- Special line-out design for bending resistance and tensile. It will upgrade the durability and life.  
/ 獨特的出線包覆設計，抗拉、耐彎曲，提升耐用度和壽命。
- The IP67 rating is designed to the effective waterproof.  
/ 保護結構達到IP67的規格，能有效的防水。
- N3/P3 model : NPN NO/NC & PNP NO/NC 2-in-1 outputs.  
/ N3/P3電路：NPN NO/NC & PNP NO/NC 2合1輸出。
- Surge suppressor and overload protection.  
/ 突波吸收，負載保護。



Model / 型號	NPN N.O. / N.C.	PSC1202-N3	PSC1202-N3B	PSC1205-N3	PSC1205-N3B
	PNP N.O. / N.C.	PSC1202-P3	PSC1202-P3B	PSC1205-P3	PSC1205-P3B
	DC 2 線式 N.O.	PSC1202-C	-	PSC1205-C	-
	DC 2 線式 N.C.	PSC1202-C2	-	PSC1205-C2	-
Sensing distance / 檢出距離	2 mm ±10%			5 mm ±10%	
Secure sensing distance / 建議距離	0 ~ 1.6 mm			0 ~ 4 mm	
Standard sensing object / 標準檢測物	Iron / 鐵 12 × 12 × 1mm				
Sensing type / 檢出方式	Shielded / 隔離型			Unshielded / 非隔離型	
Description / 外型	Standard M12 / 標準M12				
Hysteresis / 遲滯	≤10 % of sensing distance / 檢測距離的 10 %以下				
Response time / 反應頻率	800 Hz			500 Hz	
Operating voltage / 工作電壓	DC12 ~ 30 V / DC 24 V ±10%				
Current consumption / 消耗電流	≤ 14 mA no-load (Not for C/ C2)				
Load current / 負載電流	100 mA Max. at DC 24V				
Residual voltage / 殘餘電壓	≤ DC 2V / ≤ DC 7V				
Insulation resistance / 隔離阻抗	20MΩ min. (DC500V)				
Voltage withstandability / 絕緣耐壓	AC1000V 60Hz for 60 Sec.				
Operating temperature / 工作溫度	-20°C ~ +60°C				
Protection degree / 防水等級	IP 67				
Option / 選購配件	M84R-2M-PVC / M84RL-2M PVC				
Wiring method / 出線方式	N3/P3: Ø4.2x2M/3 wires C/C2: Ø4.2 x 2M/2 wires		M8 pigtailed type / M8 出線式接頭型	N3/P3: Ø4.2x2M/3 wires C/C2: Ø4.2 x 2M/2 wires	
Weight / 重量	64g		48.4g	65g	
<b>Wiring diagrams / 接線圖</b>					
<b>-N3</b>					
<b>-P3B</b>					

M12

電感式一靜電容近接開關

Ø3  
Ø4  
Ø5  
Ø6  
Ø8  
M12  
M18  
M30

JM  
JN  
KND  
PN  
PND  
RN  
SN

SID  
SIR  
SIA

KC  
KCT  
KCP

## Characteristic / 特點：

- Large LED indicator, check the operation clerly.  
/ 專利大面積動作燈，可清晰了解感測器的動作。
- M12 4pin connector model available.  
/ M12 4pin接頭外型，同步於歐、美、日。
- N3/P3 model : NPN NO/NC & PNP NO/NC 2-in-1 outputs.  
/ N3/P3電路：NPN NO/NC & PNP NO/NC 2合1輸出。
- Surge suppressor and overload protection .  
/ 突波吸收，負載保護。

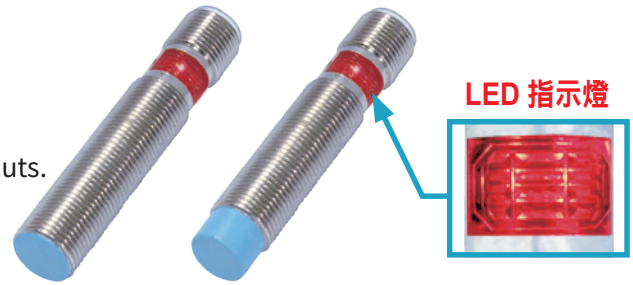

Model / 型號	NPN N.O. / N.C.	PSC1203-N3M1	PSC1205-N3M1
	PNP N.O. / N.C.	PSC1203-P3M1	PSC1205-P3M1
Sensing distance / 檢出距離		3 mm ±10%	5 mm ±10%
Secure sensing distance / 建議距離		0 ~ 2.4 mm	0 ~ 4.8 mm
Standard sensing object / 標準檢測物		Iron / 鐵 12 × 12 × 1mm	
Sensing type / 檢出方式		Shielded / 隔離型	Unshielded / 非隔離型
Description / 外型		Standard M12 / 標準M12	
Hysteresis / 遲滯		≤10 % of sensing distance / 檢測距離的 10 %以下	
Response time / 反應頻率		500 Hz	
Operating voltage / 工作電壓		DC12 ~ 30 V	
Current consumption / 消耗電流		≤ 14 mA no-load	
Load current / 負載電流		100 mA Max. at DC 24V	
Residual voltage / 殘餘電壓		≤ DC 2V	
Insulation resistance / 隔離阻抗		20MΩ min. (DC500V)	
Voltage withstandability / 絕緣耐壓		AC1000V 60Hz for 60 Sec.	
Operating temperature / 工作溫度		-20°C ~ + 60°C	
Protection degree / 防水等級		IP 66	
Option / 選購配件		M124R-PVC-2M	
Wiring method / 出線方式		M12 plug-in connector type / M12 接頭型	
Weight / 重量		18g	16g
<b>Wiring diagrams / 接線圖</b>			
<b>-N3M1</b>			
<p>(1) BROWN (3) BLUE (2) WHITE (4) BLACK</p>		<p>(1) BROWN (3) BLUE (2) WHITE (4) BLACK</p>	
<b>-P3M1</b>			
<p>(1) BROWN (3) BLUE (2) WHITE (4) BLACK</p>		<p>(1) BROWN (3) BLUE (2) WHITE (4) BLACK</p>	

M12

電感式 - 靜電容近接開關

03  
04  
M5  
06  
M8  
M12  
M18  
M30

JM  
JN  
KND  
PN  
PND  
RN  
SN

SID  
SIR  
SIA

KC  
KCT  
KCP

# M12 耐熱圓管型近接開關

Heat-Resistant Inductive Proximity Sensor

## Characteristic / 特點：

- Temperature range 110°C.  
/ 耐高溫110°C內，適合高溫作業。
- Anti-bending design.  
/ 耐彎包覆保護設計。
- Protection rating: IP67.  
/ IP67防水等級。
- 90 degree wiring for easy mounting.  
/ 90°出線，安裝便利。

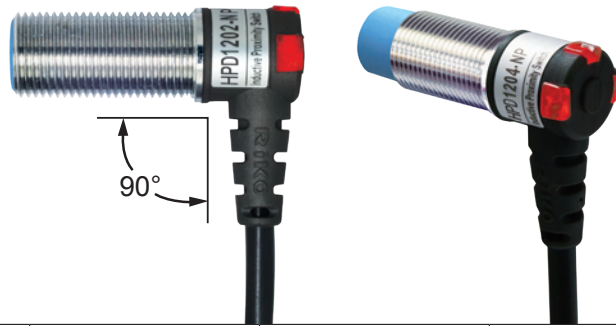

Model / 型號	NPN N.O. / N.C.	HPD1202-N	HPD1202-NB	HPD1204-N	HPD1204-NB
	PNP N.O. / N.C.	HPD1202-P	HPD1202-PB	HPD1204-P	HPD1204-PB
Sensing distance / 檢出距離	2 mm ±10%		4 mm ±10%		
Secure sensing distance / 建議距離	0 ~ 1.6 mm		0 ~ 3.2 mm		
Standard sensing object / 標準檢測物	Iron / 鐵 12 × 12 × 1mm				
Sensing type / 檢出方式	Shielded / 隔離型		Unshielded / 非隔離型		
Description / 外型	Standard M12 / 標準M12				
Hysteresis / 遲滯	≤ 10 % of sensing distance / 檢測距離的 10 % 以下				
Response time / 反應頻率	500 Hz				
Operating voltage / 工作電壓	DC 12 ~ 30 V				
Current consumption / 消耗電流	≤ 14 mA no-load				
Load current / 負載電流	100 mA				
Residual voltage / 殘餘電壓	≤ DC 2V				
Insulation resistance / 隔離阻抗	20MΩ min. (DC500V)				
Voltage withstandability / 絕緣耐壓	AC1000V 60Hz for 60 Sec.				
Operating temperature / 工作溫度	-20°C ~ + 110°C				
Protection degree / 防水等級	IP 67				
Wiring method / 出線方式	Ø4.2x2M / 3 wires	M8 pigtailed type / M8 出線式接頭型	Ø4.2x2M / 3 wires	M8 pigtailed type / M8 出線式接頭型	
Weight / 重量	49g	19g	63g	23g	
<b>Wiring diagrams / 接線圖</b>					
<b>-N</b>					
<b>-P</b>					

## Characteristic / 特點：

- Temperature range 110°C.  
/ 耐高溫110°C內，適合高溫作業。
- Anti-bending design.  
/ 耐彎包覆保護設計。
- Protection rating: IP67.  
/ IP67防水等級。

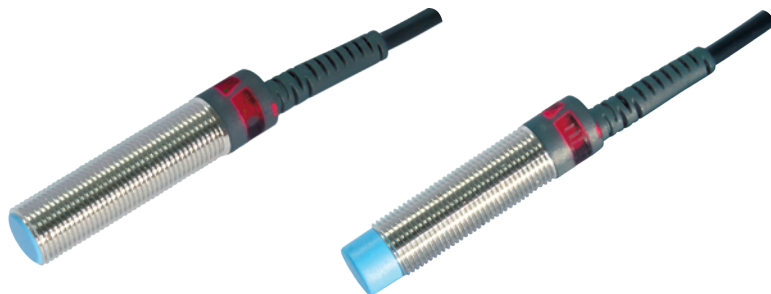

M12

電感式 - 靜電容近接開關

Ø3  
Ø4  
M5  
Ø6  
M8  
M12  
M18  
M30

JM  
JN  
KND  
PN  
PND  
RN  
SN

SID  
SIR  
SIA

KC  
KCT  
KCP

Model / 型號	NPN N.O. / N.C.	HPS1202-N	HPS1202-NB	HPS1204-N	HPS1204-NB
	PNP N.O. / N.C.	HPS1202-P	HPS1202-PB	HPS1204-P	HPS1204-PB
Sensing distance / 檢出距離	2 mm ±10%			4 mm ±10%	
Secure sensing distance / 建議距離	0 ~ 1.6 mm			0 ~ 3.2 mm	
Standard sensing object / 標準檢測物	Iron / 鐵 12 × 12 × 1mm				
Sensing type / 檢出方式	Shielded / 隔離型			Unshielded / 非隔離型	
Description / 外型	Standard M12 / 標準M12				
Hysteresis / 遲滯	≤ 10 % of sensing distance / 檢測距離的 10 % 以下				
Response time / 反應頻率	500 Hz				
Operating voltage / 工作電壓	DC 12 ~ 30 V				
Current consumption / 消耗電流	≤ 14 mA no-load				
Load current / 負載電流	100 mA				
Residual voltage / 殘餘電壓	≤ DC 2V				
Insulation resistance / 隔離阻抗	20MΩ min. (DC500V)				
Voltage withstandability / 絕緣耐壓	AC1000V 60Hz for 60 Sec.				
Operating temperature / 工作溫度	-20°C ~ + 110°C				
Protection degree / 防水等級	IP 67				
Wiring method / 出線方式	Ø4.2x2M / 3 wires	M8 pigtailed type / M8 出線式接頭型		Ø4.2x2M / 3 wires	M8 pigtailed type / M8 出線式接頭型
Weight / 重量	53g	23g		61g	21g
<b>Wiring diagrams / 接線圖</b>					
<b>-N</b>					
<b>-P</b>					

# M12 耐高壓圓管型近接開關

High Pressure  
Resistance Inductive  
Proximity Sensor

## Characteristic / 特點：

- SUS 304 full metal housing, high pressure resistance up to 500 Bar.  
/ 一體成型不銹鋼SUS 304 耐高壓 500 Bar。
- Short body length 43mm.  
/ 短本體全長43mm。
- Ceramic sensing face, high protection level.  
/ 陶瓷感應面, 防護係數高。



Model / 型號	<b>HPP-1202-P</b>
Operating distance / 檢測距離	1.5 mm ±10%
Current consumption / 消耗電流	<8 mA
Load current / 負載電流	200 mA
Operating voltage / 工作電壓	10 ~ 30 VDC
Output / 輸出模式	PNP.NO
Voltage drop / 壓降	<1.5 V @ 200 mA
Switching frequency / 開關頻率	1000 Hz
Operating temperature / 工作溫度	-25°C ~ 70°C
Protection degree / 防護等級	IP67
Casing material / 外殼材料	SS304 V2A
Connection / 連接方式	PVC, ultra-flex, 2M

## Wiring diagrams / 接線圖

-P

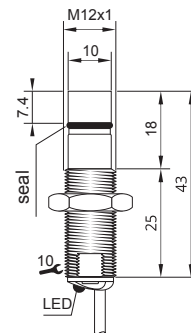
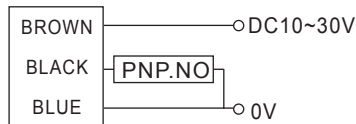

M12

電感式  
— 靜電容  
近接開關

Ø3  
Ø4  
M5  
Ø6  
M8  
M12  
M18  
M30

JM  
JN  
KND  
PN  
PND  
RN  
SN

SID  
SIR  
SIA

KC  
KCT  
KCP

## Characteristic / 特點：

- 90 degree wiring, saving space.  
/ 專利90度出線設計，節省空間。
- Large LED indicator, check the operation clearly.  
/ 大面積動作燈，可清晰了解感測器的動作。
- Anti-bending connection design.  
/ 專利包覆設計，耐彎保護佳。
- N3/P3 model : NPN N.O./N.C. & PNP N.O./N.C. 2-in-1 outputs.  
/ N3/P3電路：NPN N.O./N.C. & PNP N.O./N.C. 2合1輸出。
- Surge suppressor and overload protection.  
/ 突波吸收，負載保護。

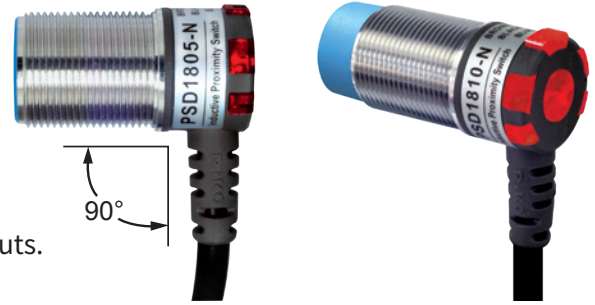

M18

電感式一靜電容近接開關

Ø3  
Ø4  
M5  
Ø6  
M8  
M12  
M18  
M30

JM  
JN  
KND  
PN  
PND  
RN  
SN

SID  
SIR  
SIA

KC  
KCT  
KCP

Model / 型號	NPN N.O. / N.C.	PSD1805-N3	PSD1805-N3K	PSD1808-N3	PSD1808-N3K
	PNP N.O. / N.C.	PSD1805-P3	PSD1805-P3K	PSD1808-P3	PSD1808-P3K
	DC 2 線式 N.O.	PSD1805-C	-	PSD1808-C	-
	DC 2 線式 N.C.	PSD1805-C2	-	PSD1808-C2	-
Sensing distance / 檢出距離	5 mm ±10%			8 mm ±10%	
Secure sensing distance / 建議距離	0 ~ 4.0 mm			0 ~ 6.4mm	
Standard sensing object / 標準檢測物	Iron / 鐵 18×18×1 mm				
Sensing type / 檢出方式	Shielded / 隔離型			Unshielded / 非隔離型	
Description / 外型	Standard M18 / 標準M18				
Hysteresis / 遲滯	≤10 % of sensing distance / 檢測距離的 10 %以下				
Response time / 反應頻率	600 Hz / 300 Hz				
Operating voltage / 工作電壓	DC 12 ~ 30 V / DC 24V ±10%				
Current consumption / 消耗電流	≤ 14 mA no-load (Not for C / C2)				
Load current / 負載電流	100 mA Max. at DC 24V				
Residual voltage / 殘餘電壓	≤ DC 2V / ≤DC 7V				
Insulation resistance / 隔離阻抗	20MΩ min. (DC500V)				
Voltage withstandability / 絕緣耐壓	AC1000V 60Hz for 60 Sec.				
Operating temperature / 工作溫度	-20°C ~ + 60°C				
Protection degree / 防水等級	IP 67				
Option / 選購配件	M124R-PVC-2M				
Wiring method / 出線方式	N3/P3: Ø5.2x2M/3 wires C/C2: Ø5.2x2M/2 wires	M12 pigtailed type / M12 出線式接頭型	N3/P3: Ø5.2x2M/3 wires C/C2: Ø5.2x2M/2 wires	M12 pigtailed type / M12 出線式接頭型	
Weight / 重量	86g	38g	86g	38g	
<h3>Wiring diagrams / 接線圖</h3>					
<h4>-N3</h4>					
<h4>-P3K</h4>					
<p>(1) BROWN (3) BLUE (2) WHITE (4) BLACK</p>					

# M18 耐彎抗拉圓管型近接開關

# Tubular Inductive Proximity Sensor

## Characteristic / 特點：

- Special line-out design for bending resistance and tensile. It will upgrade the durability and life.  
/ 獨特的出線包覆設計，抗拉、耐彎曲，提升耐用度和壽命。
- The IP67 rating is designed to the effective waterproof.  
/ 保護結構達到IP67的規格，能有效的防水。
- N3/P3 model : NPN N.O./N.C. & PNP N.O./N.C. 2-in-1 outputs.  
/ N3/P3電路：NPN N.O./N.C. & PNP N.O./N.C. 2合1輸出。
- Surge suppressor and overload protection .  
/ 突波吸收，負載保護。



Model / 型號	NPN N.O. / N.C.	PSC1805-N3	PSC1805-N3K	PSC1808-N3	PSC1808-N3K
	PNP N.O. / N.C.	PSC1805-P3	PSC1805-P3K	PSC1808-P3	PSC1808-P3K
	DC 2 線式 N.O.	PSC1805-C	-	PSC1808-C	-
	DC 2 線式 N.C.	PSC1805-C2	-	PSC1808-C2	-
Sensing distance / 檢出距離	5 mm ±10%			8 mm ±10%	
Secure sensing distance / 建議距離	0 ~ 4.0 mm / 0 ~ 4mm			0 ~ 9.6 mm / 0 ~ 6.4mm	
Standard sensing object / 標準檢測物	Iron / 鐵 18 × 18 × 1 mm				
Sensing type / 檢出方式	Shielded / 隔離型			Unshielded / 非隔離	
Description / 外型	Standard M18 / 標準M18				
Hysteresis / 遲滯	≤ 10 % of sensing distance / 檢測距離的 10 % 以下				
Response time / 反應頻率	600 Hz / 300 Hz				
Operating voltage / 工作電壓	DC 12 ~ 30 V / DC 24V ±10%				
Current consumption / 消耗電流	≤ 14 mA no-load (Not for C/ C2)				
Load current / 負載電流	100 mA Max. at DC 24V				
Residual voltage / 殘餘電壓	≤ DC 2V / ≤ DC 7V				
Insulation resistance / 隔離阻抗	20MΩ min. (DC500V)				
Voltage withstandability / 絕緣耐壓	AC1000V 60Hz for 60 Sec.				
Operating temperature / 工作溫度	-20°C ~ + 60°C				
Protection degree / 防水等級	IP 67				
Option / 選購配件	M124R-PVC-2M				
Wiring method / 出線方式	N3/P3: Ø5.2x2M/3wires C/C2: Ø5.2x2M/2 wires		M12 pigtailed type / M12 出線式接頭型	N3/P3: Ø5.2x2M/3wires C/C2: Ø5.2x2M/2 wires	
Weight / 重量	93g		40.5g	92g	
<b>Wiring diagrams / 接線圖</b>					
<b>-N3</b>					
<b>-P3K</b>					

M18

電感式一靜電容近接開關

Ø3  
Ø4  
Ø5  
Ø6  
Ø8  
Ø12  
Ø18  
Ø30

JM  
JN  
KND  
PN  
PND  
RN  
SN

SID  
SIR  
SIA

KC  
KCT  
KCP

## Characteristic / 特點：

- Large LED indicator, check the operation clearly.  
/ 大面積動作燈，可清晰了解感測器的動作。
- Assorted variety : Short body / Long body / AC or DC available.  
/ 檢測距離加長，方便使用。
- N3/P3 model : NPN N.O./N.C. & PNP N.O./N.C. 2-in-1 outputs.  
/ N3/P3電路：NPN N.O./N.C. & PNP N.O./N.C. 2合1輸出。
- Surge suppressor and overload protection .  
/ 突波吸收，負載保護。

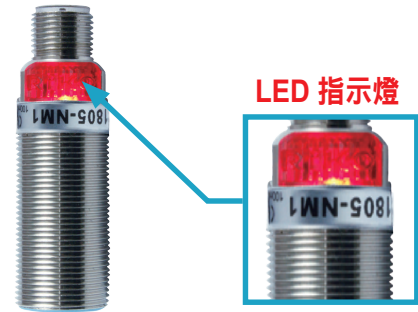

M18

電感式 - 靜電容近接開關

Ø3  
Ø4  
M5  
Ø6  
M8  
M12  
M18  
M30

JM  
JN  
KND  
PN  
PND  
RN  
SN

SID  
SIR  
SIA

KC  
KCT  
KCP

Model / 型號	NPN N.O. / N.C.	PSC1805-N3M1	PSC1812-N3M1
	PNP N.O. / N.C.	PSC1805-P3M1	PSC1812-P3M1
Sensing distance / 檢出距離		5 mm ±10%	12 mm ±10%
Secure sensing distance / 建議距離		0 ~ 4 mm	0 ~ 9.6 mm
Standard sensing object / 標準檢測物	Iron / 鐵 18 × 18 × 1 mm		
Sensing type / 檢出方式		Shielded / 隔離型	Unshielded / 非隔離型
Description / 外型	Standard M18 / 標準M18		
Hysteresis / 遲滯	≤10 % of sensing distance / 檢測距離的 10 %以下		
Response time / 反應時間	500 Hz		
Operating voltage / 工作電壓	DC 12 ~ 30 V		
Current consumption / 消耗電流	≤ 14 mA no-load		
Load current / 負載電流	100 mA		
Residual voltage / 殘餘電壓	≤ DC 2V		
Insulation resistance / 隔離阻抗	20MΩ min. (DC500V)		
Voltage withstandability / 絕緣耐壓	AC1000V 60Hz for 60 Sec.		
Operating temperature / 工作溫度	-20°C ~ + 60°C		
Protection degree / 防水等級	IP 66		
Option / 選購配件	M124R-PVC-2M		
Wiring method / 出線方式	M12 plug-in connector type / M12 接頭型		
Weight / 重量	30g		30g
<b>Wiring diagrams / 接線圖</b>			
<b>-N3M1</b>			
<p>(1) BROWN (3) BLUE (2) WHITE (4) BLACK</p>			
<b>-P3M1</b>			
<p>(1) BROWN (3) BLUE (2) WHITE (4) BLACK</p>			

# M18 耐熱圓管型近接開關

Heat-Resistant  
Inductive Proximity  
Sensor

## Characteristic / 特點：

- Temperature range 110°C.  
/ 耐高溫110°C內，適合高溫作業。
- Anti-bending design.  
/ 耐彎包覆保護設計。
- Protection rating: IP67.  
/ IP67防水等級。
- 90 degree wiring for easy mounting.  
/ 90°出線，安裝便利。

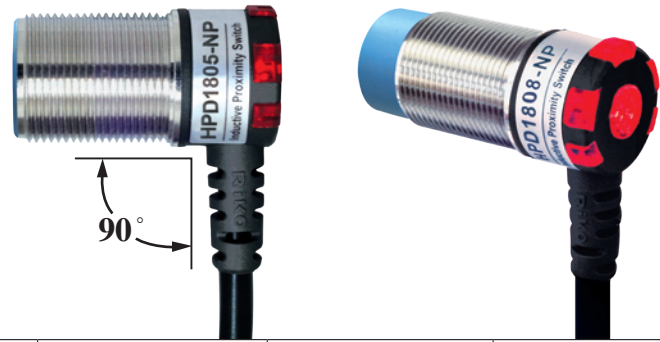

Model / 型號	NPN N.O.	HPD1805-N	HPD1805-NK	HPD1808-N	HPD1808-NK
	PNP N.O.	HPD1805-P	HPD1805-PK	HPD1808-P	HPD1808-PK
Sensing distance / 檢出距離	5 mm ±10%			8 mm ±10%	
Secure sensing distance / 建議距離	0 ~ 4.0 mm			0 ~ 6.4 mm	
Standard sensing object / 標準檢測物	Iron / 鐵 18 × 18 × 1 mm				
Sensing type / 檢出方式	Shielded / 隔離型			Unshielded / 非隔離型	
Description / 外型	Standard M18 / 標準M18				
Hysteresis / 遲滯	≤10 % of sensing distance / 檢測距離的 10% 以下				
Response time / 反應頻率	500 Hz				
Operating voltage / 工作電壓	DC 12 ~ 30 V				
Current consumption / 消耗電流	≤ 14 mA no-load				
Load current / 負載電流	100 mA				
Residual voltage / 殘餘電壓	≤ DC 2V				
Insulation resistance / 隔離阻抗	20MΩ min. (DC500V)				
Voltage withstandability / 絕緣耐壓	AC1000V 60Hz for 60 Sec.				
Operating temperature / 工作溫度	-20°C ~ + 110°C				
Protection degree / 防水等級	IP 67				
Wiring method / 出線方式	Ø5.2 x 2M / 3 wires	M12 pigtailed type	Ø5.2 x 2M / 3 wires	M12 pigtailed type	
Weight / 重量	86g	38g	86g	38g	
<b>Wiring diagrams / 接線圖</b>					
<b>-N</b>					
<b>-P</b>					

M18

電感式  
靜電容  
近接開關

Ø3  
Ø4  
M5  
Ø6  
M8  
M12  
M18  
M30

JM  
JN  
KND  
PN  
PND  
RN  
SN

SID  
SIR  
SIA

KC  
KCT  
KCP

## Characteristic / 特點：

- Temperature range 110°C.  
/ 耐高溫110°C內，適合高溫作業。
- Anti-bending design.  
/ 耐彎包覆保護設計。
- Protection rating: IP67.  
/ IP67防水等級。



M18

電感式 - 靜電容近接開關

Ø3  
Ø4  
M5  
Ø6  
M8  
M12  
M18  
M30

JM  
JN  
KND  
PN  
PND  
RN  
SN

SID  
SIR  
SIA

KC  
KCT  
KCP

Model / 型號	NPN N.O.	HPS1805-N	HPS1805-NK	HPS1808-N	HPS1808-NK
	PNP N.O.	HPS1805-P	HPS1805-PK	HPS1808-P	HPS1808-PK
Sensing distance / 檢出距離	5 mm ±10%			8 mm ±10%	
Secure sensing distance / 建議距離	0 ~ 4 mm			0 ~ 6.4 mm	
Standard sensing object / 標準檢測物	Iron / 鐵 18 × 18 × 1 mm				
Sensing type / 檢出方式	Shielded / 隔離型			Unshielded / 非隔離型	
Description / 外型	Standard M18 / 標準M18				
Hysteresis / 遲滯	≤ 10 % of sensing distance / 檢測距離的 10 %以下				
Response time / 反應頻率	500 Hz				
Operating voltage / 工作電壓	DC 12 ~ 30 V				
Current consumption / 消耗電流	≤ 14 mA no-load				
Load current / 負載電流	100 mA				
Residual voltage / 殘餘電壓	≤ DC 2V				
Insulation resistance / 隔離阻抗	20MΩ min. (DC500V)				
Voltage withstandability / 絕緣耐壓	AC1000V 60Hz for 60 Sec.				
Operating temperature / 工作溫度	-20°C ~ + 110°C				
Protection degree / 防水等級	IP 67				
Wiring method / 出線方式	Ø5.2 x 2M / 3 wires	M12 pigtailed type	Ø5.2 x 2M / 3 wires	M12 pigtailed type	
Weight / 重量	93g	40.5g	92g	39.5g	
<b>Wiring diagrams / 接線圖</b>					
<b>-N</b>					
<b>-P</b>					

# M18 模擬量/電感式圓管型近接開關

### Characteristic / 特點：

- Good linear output for machine stably control.  
/ 良好的線性輸出，增加機台穩定的控制。
- Applications : RPM and displacment control.  
/ 適合用於位移控制與轉速控制。
- Anti-bending design.  
/ 耐彎包覆保護設計。
- Two outputs models : 0~10V / 4~20mA.  
/ 兩種輸出可選用：0-10V及4-20mA。

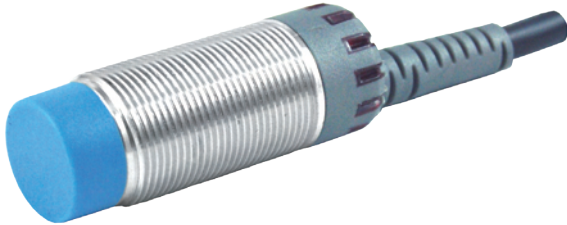

Model / 型號	PSC1808-LA03	PSC1808-LV03
Sensing distance / 檢出距離	8 mm ±10%	
Standard sensing object / 標準檢測物	Iron / 鐵 18 x 18 x 1 mm	
Ripple / 漣波因素	≤ 20%	
Operating voltage / 工作電壓	DC 15 ~ 24V	
Current consumption / 消耗電流	35 mA Max.	
Load resistance / 負載阻抗	390 Ω 4~20 mA	> 10KΩ 0~10 V
Output protection / 輸出保護	Input power polarity reversal protection / 電源輸入極性保護 Output power short-circuit protection / 輸出功率短路保護	
No-load supply current / 無負載電流	≤ 10 mA	
Temperature drift / 溫度誤差	≤ 15% Sr	
Insulation resistance / 隔離阻抗	20M Ω min. (DC 500V)	
Voltage withstandability / 絕緣耐壓	AC1000V 60Hz for 60 Sec.	
Operating temperature / 工作溫度	-20°C ~ +60°C	
Protection degree / 防水等級	IP67	
Wiring method / 出線方式	Pre-wired Ø5.2 x 2 M / 3 wires	
Weight / 重量	93g	

Dimensions / 尺寸圖 (mm)	Wiring diagrams & Response diagrams / 接線圖 & 曲線圖
	<p><b>PSC1808-LA03</b></p>
	<p><b>PSC1808-LV03</b></p>

M18

電感式  
— 靜電容  
近接開關

Ø3  
Ø4  
M5  
Ø6  
M8  
M12  
M18  
M30

JM  
JN  
KND  
PN  
PND  
RN  
SN

SID  
SIR  
SIA

KC  
KCT  
KCP

## Characteristic / 特點：

- 90 degree design fits for limited space.  
/ 90°直角設計，合適有限空間安裝。
- Large LED indicator, check the operation clerly.  
/ 大面積動作燈，可清晰了解感測器的動作。
- Anti-bending design.  
/ 耐彎包覆保護設計。
- N3/P3 model : NPN N.O./N.C. & PNP N.O./N.C. 2-in-1 outputs.  
/ N3/P3電路：NPN N.O./N.C. & PNP N.O./N.C. 2合1輸出。
- Surge suppressor and overload protection .  
/ 突波吸收，負載保護。

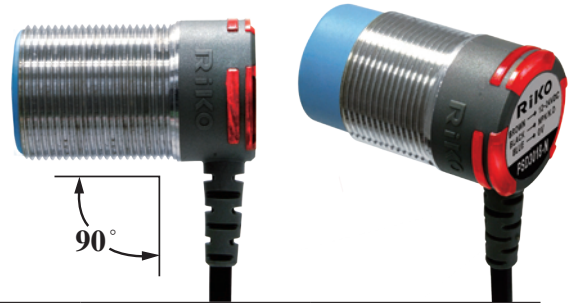

M30

電感式 - 靜電容近接開關

Ø3  
Ø4  
M5  
Ø6  
M8  
M12  
M18  
M30

JM  
JN  
KND  
PN  
PND  
RN  
SN

SID  
SIR  
SIA

KC  
KCT  
KCP

Model / 型號	NPN N.O. / N.C.	PSD3010-N3	PSD3010-N3K	PSD3018-N3	PSD3018-N3K
	PNP N.O. / N.C.	PSD3010-P3	PSD3010-P3K	PSD3018-P3	PSD3018-P3K
Sensing distance / 檢出距離	10 mm ±10%			18 mm ±10%	
Secure sensing distance / 建議距離	0 ~ 8 mm			0 ~ 14.4 mm	
Standard sensing object / 標準檢測物	Iron / 鐵 30 × 30 × 1 mm				
Sensing type / 檢出方式	Shielded / 隔離型			Unshielded / 非隔離型	
Description / 外型	Standard M30 / 標準M30				
Hysteresis / 遲滯	≤ 10 % of sensing distance / 檢測距離的 10 % 以下				
Response time / 反應頻率	300Hz				
Operating voltage / 工作電壓	DC 12 ~ 30 V				
Current consumption / 消耗電流	≤ 14 mA no-load				
Load current / 負載電流	100 mA				
Residual voltage / 殘餘電壓	≤ DC 2V				
Insulation resistance / 隔離阻抗	20MΩ min. (DC500V)				
Voltage withstandability / 絕緣耐壓	AC1000V 60Hz for 60 Sec.				
Operating temperature / 工作溫度	-20°C ~ + 60°C				
Protection degree / 防水等級	IP 67				
Option / 選購配件	M124R-PVC-2M				
Wiring method / 出線方式	Ø5.2 x 2M/ 3 wires	M12 pigtailed type / M12 出線式接頭型	Ø5.2 x 2M/ 3 wires	M12 pigtailed type / M12 出線式接頭型	M12 pigtailed type / M12 出線式接頭型
Weight / 重量	145g	95g	145g	95g	95g
<b>Wiring diagrams / 接線圖</b>					
<b>-N3</b>					
<b>-N3K</b>					
<b>-P3</b>					

# M30 耐彎抗拉圓管型近接開關

# Tubular Inductive Proximity Sensor

## Characteristic / 特點：

- Special line-out design for bending resistance and tensile. It will upgrade the durability and life.  
/ 獨特的出線包覆設計，抗拉、耐彎曲，提升耐用度和壽命。
- The IP67 rating is designed to the effective waterproof.  
/ 保護結構達到IP67的規格，能有效的防水。
- M30 sensing distance up to 25mm.  
/ M30型超長檢測距離達25mm。
- N3/P3 model : NPN N.O./N.C. & PNP N.O./N.C. 2-in-1 outputs.  
/ N3/P3電路：NPN N.O./N.C. & PNP N.O./N.C. 2合1輸出。
- Surge suppressor and overload protection .  
/ 突波吸收，負載保護。

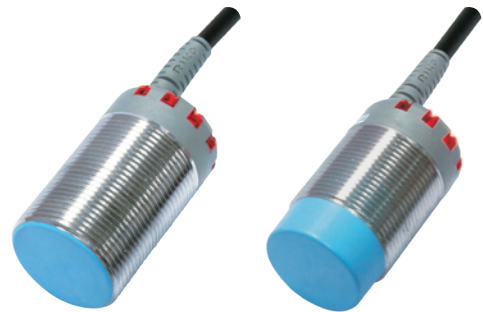

Model / 型號	NPN N.O. / N.C.	PSC3010-N3	PSC3010-N3K	PSC3018-N3	PSC3018-N3K
	PNP N.O. / N.C.	PSC3010-P3	PSC3010-P3K	PSC3018-P3	PSC3018-P3K
Sensing distance / 檢出距離	12mm ±10%			18mm ±10%	
Secure sensing distance / 建議距離	0 ~ 9.6mm			0 ~ 14.4 mm	
Standard sensing object / 標準檢測物	Iron / 鐵 30×30×1 mm				
Sensing type / 檢出方式	Shielded / 隔離型			Unshielded / 非隔離型	
Description / 外型	Standard M30 / 標準M30				
Hysteresis / 遲滯	≤10 % of sensing distance / 檢測距離的 10% 以下				
Response time / 反應頻率	300 Hz				
Operating voltage / 工作電壓	DC 12 ~ 30 V				
Current consumption / 消耗電流	≤ 16 mA no-load				
Load current / 負載電流	100 mA				
Residual voltage / 殘餘電壓	≤ DC 2V				
Insulation resistance / 隔離阻抗	20MΩ min. (DC500V)				
Voltage withstandability / 絕緣耐壓	AC1000V 60Hz for 60 Sec.				
Operating temperature / 工作溫度	-20°C ~ + 60°C				
Protection degree / 防水等級	IP 67				
Option / 選購配件	M124R-PVC-2M				
Wiring method / 出線方式	Ø5.2 x 2M/ 3 wires	M12 pigtailed type / M12 出線式接頭型	Ø5.2 x 2M/ 3 wires	M12 pigtailed type / M12 出線式接頭型	M12 pigtailed type / M12 出線式接頭型
Weight / 重量	141g	88.5g	129g	76.5g	76.5g
<b>Wiring diagrams / 接線圖</b>					
<b>-N3</b>					
<b>-N3K</b>					
<p>(1) BROWN (3) BLUE (2) WHITE (4) BLACK</p>					
<b>-P3</b>					

M30

電感式一靜電容近接開關

Ø3  
Ø4  
M5  
Ø6  
M8  
M12  
M18  
M30

JM  
JN  
KND  
PN  
PND  
RN  
SN

SID  
SIR  
SIA

KC  
KCT  
KCP

## Characteristic / 特點：

- Inductive sensing, metal detection.  
/ 標準型 含鐵金屬檢測有無。
- Non-shielded, sensing 25mm.  
/ 非隔離型 25mm 檢測距離。
- IP67 protection degree.  
/ IP67 防護等級。
- Operating temperature -25~75°C.  
/ 工作溫度 -25 ~+75 度。



M30

電感式 - 靜電容近接開關

Ø3  
Ø4  
M5  
Ø6  
M8  
M12  
M18  
M30

JM  
JN  
KND  
PN  
PND  
RN  
SN

SID  
SIR  
SIA

KC  
KCT  
KCP

Model / 型號	SC3025-N
Operating distance / 檢測距離	25 mm ±10%
Current consumption / 消耗電流	<8 mA
Load current / 負載電流	200 mA
Operating voltage / 工作電壓	10~ 30 VDC
Output / 輸出模式	NPN.NO
Voltage drop / 壓降	<1.5 V @ 200 mA
Switching frequency / 開關頻率	100 Hz
Operating temperature / 工作溫度	-25°C ~ 75°C
Protection degree / 防護等級	IP67
Casing material / 外殼材料	brass
Connection / 連接方式	PVC, ultra-flex
<b>Wiring diagrams / 接線圖</b>	
<b>-N</b>	

# M30 耐彎抗拉圓管型近接開關

# Tubular Inductive Proximity Sensor

## Characteristic / 特點：

- Large LED indicator, check the operation clearly.  
/ 大面積動作燈，可清晰了解感測器的動作。
- M12 4pin connector model available.  
/ M12 4pin接頭外型，同步於歐、美、日。
- N3/P3 model : NPN N.O./N.C. & PNP N.O./N.C. 2-in-1 outputs.  
/ N3/P3電路：NPN N.O./N.C. & PNP N.O./N.C. 2合1輸出。
- Surge suppressor and overload protection.  
/ 突波吸收，負載保護。



Model / 型號	NPN N.O. / N.C.	PSC3012-N3M1	PSC3018-N3M1
	PNP N.O. / N.C.	PSC3012-P3M1	PSC3018-P3M1
Sensing distance / 檢出距離		12 mm ±10%	18 mm ±10%
Secure sensing distance / 建議距離		0 ~ 9.6 mm	0 ~ 14.4 mm
Standard sensing object / 標準檢測物	Iron / 鐵 30 x 30 x 1 mm		
Sensing type / 檢出方式		Shielded / 隔離型	Unshielded / 非隔離型
Description / 外型	Standard M30 / 標準M30		
Hysteresis / 遲滯	≤ 10 % of sensing distance		
Response time / 反應頻率	300 Hz		
Operating voltage / 工作電壓	DC 12 ~ 30 V		
Current consumption / 消耗電流	≤ 16 mA no-load		
Load current / 負載電流	100 mA		
Residual voltage / 殘餘電壓	≤ DC 2V		
Insulation resistance / 隔離阻抗	20MΩ min. (DC500V)		
Voltage withstandability / 絕緣耐壓	AC1000V 60Hz for 60 Sec.		
Operating temperature / 工作溫度	-20°C ~ + 60°C		
Protection degree / 防水等級	IP 66		
Option / 選購配件	M124R-PVC-2M		
Wiring method / 出線方式	M12 plug-in connector type / M12 接頭型		
Weight / 重量	70g		66g
<b>Wiring diagrams / 接線圖</b>			
<b>-N3M1</b>			
<p>(1) BROWN (3) BLUE (2) WHITE (4) BLACK</p>			
<b>-P3M1</b>			
<p>(1) BROWN (3) BLUE (2) WHITE (4) BLACK</p>			

M30

電感式一靜電容近接開關

- Ø3
- Ø4
- M5
- Ø6
- M8
- M12
- M18
- M30

- JM
- JN
- KND
- PN
- PND
- RN
- SN

- SID
- SIR
- SIA

- KC
- KCT
- KCP

## Characteristic / 特點：

- Temperature range 110°C.  
/ 耐高溫110°C內，適合高溫作業。
- Anti-bending design.  
/ 耐彎包覆保護設計。
- Protection rating: IP67.  
/ IP67防水等級。
- 90 degree wiring for easy mounting.  
/ 90°出線，安裝便利。

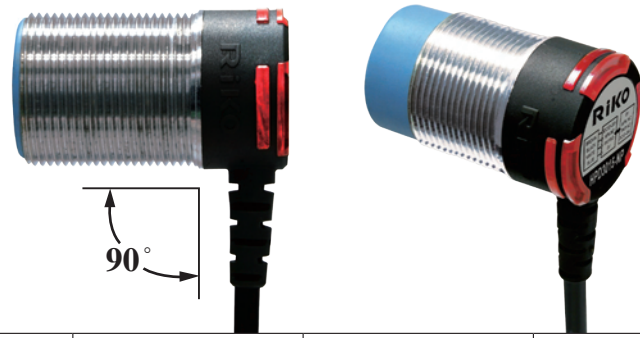

M30

電感式 - 靜電容近接開關

Ø3  
Ø4  
M5  
Ø6  
M8  
M12  
M18  
M30

JM  
JN  
KND  
PN  
PND  
RN  
SN

SID  
SIR  
SIA

KC  
KCT  
KCP

Model / 型號	NPN N.O.	HPD3010-N	HPD3010-NK	HPD3015-N	HPD3015-NK
	PNP N.O.	HPD3010-P	HPD3010-PK	HPD3015-P	HPD3015-PK
Sensing distance / 檢出距離	10 mm ±10%			15 mm ±10%	
Secure sensing distance / 建議距離	0 ~ 8 mm			0 ~ 12 mm	
Standard sensing object / 標準檢測物	Iron / 鐵 30 × 30 × 1 mm				
Sensing type / 檢出方式	Shielded / 隔離型			Unshielded / 非隔離型	
Description / 外型	Standard M30 / 標準M30				
Hysteresis / 遲滯	≤10 % of sensing distance				
Response time / 反應頻率	300 Hz				
Operating voltage / 工作電壓	DC 12 ~ 30 V				
Current consumption / 消耗電流	DC : ≤ 14 mA no-load				
Load current / 負載電流	100 mA				
Residual voltage / 殘餘電壓	≤ DC 2V				
Insulation resistance / 隔離阻抗	20MΩ min. (DC500V)				
Voltage withstandability / 絕緣耐壓	AC1000V 60Hz for 60 Sec.				
Operating temperature / 工作溫度	-20°C ~ + 110°C				
Protection degree / 防水等級	IP 67				
Wiring method / 出線方式	Ø5.2 x 2M / 3 wires	M12 pigtailed type / M12 出線式接頭型	Ø5.2 x 2M / 3 wires	M12 pigtailed type / M12 出線式接頭型	
Weight / 重量	145g	95g	145g	95g	
<b>Wiring diagrams / 接線圖</b>					
<b>-N</b>					
<b>-P</b>					

# M30 耐熱圓管型近接開關

Heat-Resistant  
Inductive Proximity  
Sensor

## Characteristic / 特點：

- Temperature range 110°C.  
/ 耐高溫110°C內，適合高溫作業。
- Anti-bending design.  
/ 耐彎包覆保護設計。
- Protection rating: IP67.  
/ IP67防水等級。



Model / 型號	NPN N.O.	HPS3010-N	HPS3010-NK	HPS3015-N	HPS3015-NK
	PNP N.O.	HPS3010-P	HPS3010-PK	HPS3015-P	HPS3015-PK
Sensing distance / 檢出距離	10mm			15mm	
Secure sensing distance / 建議距離	0 ~ 8mm			0 ~ 12 mm	
Standard sensing object / 標準檢測物	Iron / 鐵 30 × 30 × 1 mm				
Sensing type / 檢出方式	Shielded / 隔離型			Unshielded / 非隔離型	
Description / 外型	Standard M30 / 標準M30				
Hysteresis / 遲滯	≤ 10 % of sensing distance				
Response time / 反應頻率	3.3 ms Max.				
Operating voltage / 工作電壓	DC 12 ~ 30 V				
Current consumption / 消耗電流	DC : ≤ 16 mA no-load				
Load current / 負載電流	200 mA				
Residual voltage / 殘餘電壓	≤ DC 2V				
Insulation resistance / 隔離阻抗	20MΩ min. (DC500V)				
Voltage withstandability / 絕緣耐壓	AC1000V 60Hz for 60 Sec.				
Operating temperature / 工作溫度	-20°C ~ + 110°C				
Protection degree / 防水等級	IP 67				
Wiring method / 出線方式	Ø5.2 x 2M / 3 wires	M12 pigtailed type / M12 出線式接頭型	Ø5.2 x 2M / 3 wires	M12 pigtailed type / M12 出線式接頭型	
Weight / 重量	141g	88.5g	129g	76.5g	
<b>Wiring diagrams / 接線圖</b>					
<b>-N</b>					
<b>-P</b>					

M30

電感式 - 靜電容近接開關

Ø3  
Ø4  
M5  
Ø6  
M8  
M12  
M18  
M30

JM  
JN  
KND  
PN  
PND  
RN  
SN

SID  
SIR  
SIA

KC  
KCT  
KCP

## Precautions proper installation / 安裝注意事項

### PSD 系列

#### Mounting with nut / 螺母安裝

Shielded / 隔離型

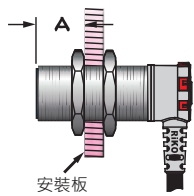

安裝板

Unshielded / 非隔離型

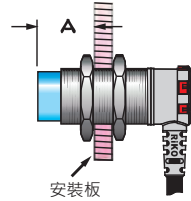

安裝板

Sensing surface	Model	A (mm)
Shielded / 隔離型	PSD0801	≥ 0
	PSD1202	≥ 0
	PSD1805	≥ 0
	PSD3010	≥ 0
Unshielded / 非隔離型	PSD0803	≥ 6
	PSD1205	≥ 15
	PSD1808	≥ 22
	PSD1810	≥ 22
	PSD3015	≥ 30
	PSD3018	≥ 30

#### Crosstalk prevention / 相互干擾

當多個感測器並列或對向安裝，預防相互干擾，請參照建議安裝距離，如下表：

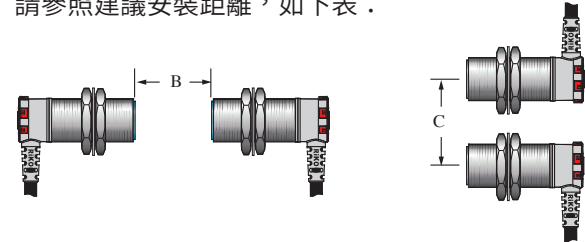

Sensing surface	Model	B (mm)	C (mm)
Shielded / 隔離型	PSD0801	≥ 5	≥ 15
	PSD1202	≥ 10	≥ 20
	PSD1805	≥ 12	≥ 30
	PSD3010	≥ 50	≥ 45
Unshielded / 非隔離型	PSD0803	≥ 8	≥ 15
	PSD1205	≥ 10	≥ 20
	PSD1808	≥ 16	≥ 30
	PSD1810	≥ 16	≥ 30
	PSD3015	≥ 60	≥ 45
	PSD3018	≥ 60	≥ 45

#### Influenced by surrounding metals. / 周圍金屬影響

避免環境干擾，請參照建議安裝距離表格如下

Shielded / 隔離型

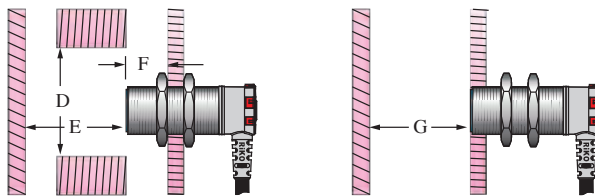

Model	D (mm)	E (mm)	F (mm)	G (mm)
PSD0801	≥ 12	≥ 4	≥ 0	≥ 4
PSD1202	≥ 20	≥ 8	≥ 0	≥ 8
PSD1805	≥ 30	≥ 20	≥ 0	≥ 20
PSD3010	≥ 50	≥ 40	≥ 0	≥ 40

Unshielded / 非隔離型

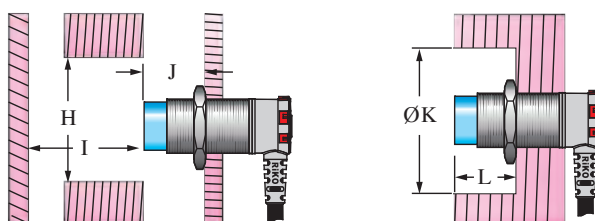

Model	H (mm)	I (mm)	J (mm)	K (mm)	L (mm)
PSD0803	≥ 22	≥ 8	≥ 6	≥ 22	≥ 6
PSD1205	≥ 36	≥ 20	≥ 15	≥ 40	≥ 15
PSD1808	≥ 54	≥ 40	≥ 22	≥ 40	≥ 15
PSD1810	≥ 54	≥ 40	≥ 22	≥ 55	≥ 22
PSD3015	≥ 90	≥ 70	≥ 30	≥ 90	≥ 30
PSD3018	≥ 90	≥ 70	≥ 30	≥ 90	≥ 30

## Precautions proper installation / 安裝注意事項

### PSC 系列

#### Mounting with nut / 螺母安裝

Shielded / 隔離型

Unshielded / 非隔離型

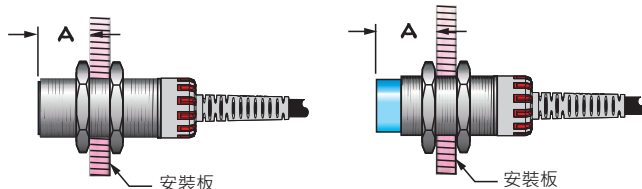

Sensing surface	Model	A (mm)
Shielded / 隔離型	PSC0801	≥ 0
	PSC1202	≥ 0
	PSC1203	≥ 0
	PSC1805	≥ 0
	PSC1806	≥ 0
	PSC3010	≥ 0
	PSC3012	≥ 0
Unshielded / 非隔離型	PSC0802	≥ 6
	PSC1205	≥ 15
	PSC1206	≥ 15
	PSC1808	≥ 22
	PSC1812	≥ 22
	PSC3018	≥ 30
	PSC3025	≥ 40

#### Crosstalk prevention / 相互干擾

當多個感測器並列或對向安裝，預防相互干擾，請參照建議安裝距離(如下表)

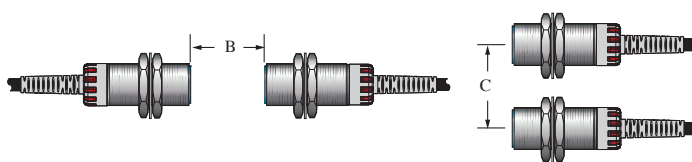

Sensing surface	Model	B (mm)	C (mm)
Shielded / 隔離型	PSC0801	≥ 5	≥ 15
	PSC1202	≥ 10	≥ 20
	PSC1203	≥ 10	≥ 20
	PSC1805	≥ 12	≥ 30
	PSC1806	≥ 15	≥ 30
	PSC3010	≥ 50	≥ 45
	PSC3012	≥ 50	≥ 45
Unshielded / 非隔離型	PSC0802	≥ 6	≥ 15
	PSC1205	≥ 20	≥ 20
	PSC1206	≥ 20	≥ 20
	PSC1808	≥ 25	≥ 30
	PSC1812	≥ 25	≥ 30
	PSC3018	≥ 60	≥ 45
	PSC3025	≥ 70	≥ 60

#### Influenced by surrounding metals. / 周圍金屬影響

避免環境干擾，請參照建議安裝距離表格如下

Shielded / 隔離型

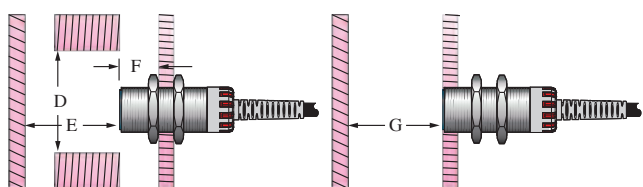

Model	D (mm)	E (mm)	F (mm)	G (mm)
PSC0801	≥ 12	≥ 4	≥ 0	≥ 4
PSC1202	≥ 20	≥ 8	≥ 0	≥ 8
PSC1203	≥ 20	≥ 10	≥ 0	≥ 10
PSC1805	≥ 30	≥ 20	≥ 0	≥ 20
PSC1806	≥ 30	≥ 30	≥ 0	≥ 30
PSC3010	≥ 50	≥ 40	≥ 0	≥ 40
PSC3012	≥ 50	≥ 50	≥ 0	≥ 50

Unshielded / 非隔離型

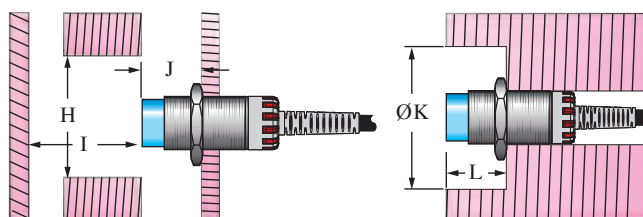

Model	H (mm)	I (mm)	J (mm)	K (mm)	L (mm)
PSC0802	≥ 22	≥ 8	≥ 6	≥ 22	≥ 6
PSC1205	≥ 36	≥ 20	≥ 15	≥ 40	≥ 15
PSC1206	≥ 36	≥ 20	≥ 15	≥ 40	≥ 15
PSC1808	≥ 54	≥ 40	≥ 22	≥ 55	≥ 22
PSC1812	≥ 60	≥ 45	≥ 25	≥ 60	≥ 25
PSC3018	≥ 90	≥ 70	≥ 30	≥ 90	≥ 30
PSC3025	≥ 105	≥ 85	≥ 45	≥ 105	≥ 45

電感式一靜電容近接開關

Ø3  
Ø4  
M5  
Ø6  
M8  
M12  
M18  
M30

JM  
JN  
KND  
PN  
PND  
RN  
SN

SID  
SIR  
SIA

KC  
KCT  
KCP

## HPD 系列

Influenced by surrounding metals. / 周圍金屬影響

避免環境干擾，請參照建議安裝距離表格如下

### Shielded / 隔離型

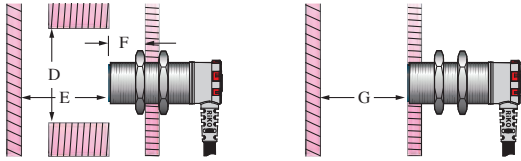

Model	D (mm)	E (mm)	F (mm)	G (mm)
HPD1202	≥20	≥8	≥0	≥8
HPD1805	≥30	≥20	≥0	≥20
HPD3010	≥50	≥40	≥0	≥40

### Unshielded / 非隔離型

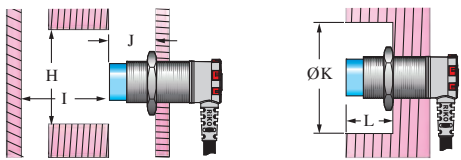

Model	H (mm)	I (mm)	J (mm)	K (mm)	L (mm)
HPD1204	≥36	≥20	≥15	≥40	≥15
HPD1808	≥54	≥40	≥22	≥55	≥22
HPD3015	≥90	≥70	≥30	≥90	≥30

## HPS 系列

### Mounting with nut / 螺母安裝

#### Shielded / 隔離型

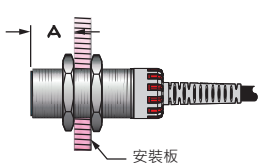

#### Unshielded / 非隔離型

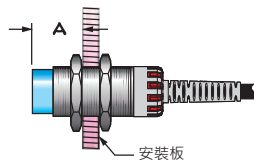

Sensing surface	Model	A (mm)
Shielded / 隔離型	HPS1202	≥0
	HPS1805	≥0
	HPS3010	≥0
Unshielded / 非隔離型	HPS1204	≥15
	HPS1808	≥22
	HPS3015	≥30

### Crosstalk prevention / 相互干擾

當多個感測器並列或對向安裝，預防相互干擾，請參照建議安裝距離(如下表)

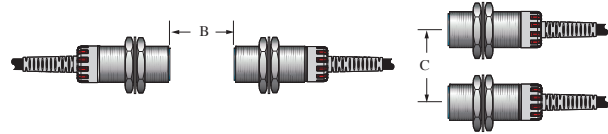

Sensing surface	Model	B (mm)	C (mm)
Shielded / 隔離型	HPS1202	≥10	≥20
	HPS1805	≥15	≥30
	HPS3010	≥50	≥45
Unshielded / 非隔離型	HPS1204	≥20	≥20
	HPS1808	≥25	≥30
	HPS3015	≥60	≥45

Influenced by surrounding metals. / 周圍金屬影響

避免環境干擾，請參照建議安裝距離表格如下

### Shielded / 隔離型

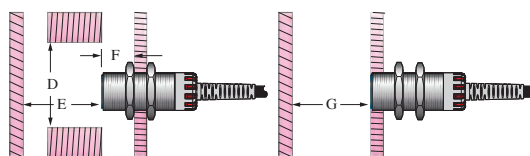

Model	D (mm)	E (mm)	F (mm)	G (mm)
HPS1202	≥20	≥8	≥0	≥8
HPS1805	≥30	≥20	≥0	≥20
HPS3010	≥50	≥40	≥0	≥40

### Unshielded / 非隔離型

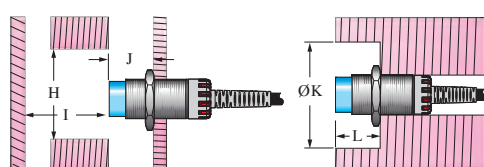

Model	H (mm)	I (mm)	J (mm)	K (mm)	L (mm)
HPS1204	≥36	≥20	≥15	≥40	≥15
HPS1805	≥54	≥40	≥22	≥55	≥22
HPS3015	≥90	≥70	≥30	≥90	≥30

# 方形電感式近接開關

# OPTIONS

## 訂貨索引

JN D 04 - N B

Metal Casing Micro Inductive Sensor  
金屬方形電感式近接開關 JM

Rectangular Inductive Proximity Sensor  
小型方形電感式近接開關 JN

Miniature Rectangular Inductive Proximity Sensor  
精巧方形電感式近接開關 KN

Anti-Bending Rectangular Inductive Proximity Sensor  
耐彎抗拉方形電感式近接開關 PN

Twin LED Rectangular Inductive Proximity Sensor  
雙LED方形電感式近接開關 RN

Rectangular Inductive Proximity Sensor  
方形電感式近接開關 SN

Top sensing surface  
前方感應

Front sensing surface  
上方感應 D

- B** M8 Pigtailed type (4pin)  
M8接頭15cm電線式 (4pin)
- B1** M8 plug-in connector type  
M8接頭型 (4pin)
- K** M12 Pigtailed type  
M12出線式接頭型(15cm)
- K1** M12 Plug-in connector type  
M12接頭型
- Pre-wired 2M model  
出線式 2M

- N3** Output NPN N.O. / N.C.  
輸出 NPN N.O. / N.C.
- P3** Output PNP N.O. / N.C.  
輸出 PNP N.O. / N.C.
- KP2** NPN.NO/NC & PNP.NC/NO  
All in one 四合一

※部分機種提供 N / P / N2 / P2

- 02** Sensing distance  
檢測距離 2mm
- 04** Sensing distance  
檢測距離 4mm
- 05** Sensing distance  
檢測距離 5mm
- 10** Sensing distance  
檢測距離 10mm
- 15** Sensing distance  
檢測距離 15mm
- 16** Sensing distance  
檢測距離 16mm
- 18** Sensing distance  
檢測距離 18mm
- 20** Sensing distance  
檢測距離 20mm
- 25** Sensing distance  
檢測距離 25mm
- 28** Sensing distance  
檢測距離 28mm

電感式一靜電容近接開關

- Ø3
- Ø4
- Ø5
- Ø6
- M8
- M12
- M18
- M30

- JM
- JN
- KND
- PN
- PND
- RN
- SN

- SID
- SIR
- SIA

- KC
- KCT
- KCP

## Characteristic / 特點：

- Surge suppressor and overload protection .  
/ 突波吸收，負載保護。
- Small dimension: 8.5x5.5x24mm.  
/ 尺寸迷你，僅8.5x5.5x24mm。
- Compact and durable.  
/ 金屬外殼，堅固耐用。
- Single screw hole fixing.  
/ 單螺絲方便固定。



Model / 型號	NPN N.O.	JM02-N	JM02-NB	JMD02-N	JMD02-NB
	NPN N.C.	JM02-N2	JM02-N2B	JMD02-N2	JMD02-N2B
	PNP N.O.	JM02-P	JM02-PB	JMD02-P	JMD02-PB
	PNP N.C.	JM02-P2	JM02-P2B	JMD02-P2	JMD02-P2B
Sensing distance / 檢出距離		2 mm ±10%			
Secure sensing distance / 建議距離		0 ~1.6 mm			
Standard sensing object / 標準檢測物		Iron / 鐵 8 × 8 × 1mm			
Sensing type / 檢出方式		Top surface / 前方		Front surface / 上方	
Description / 外型		Standard M8 / 標準M8			
Hysteresis / 遲滯		≤ 10 % of sensing distance / 檢測距離的 10 %以下			
Response time / 反應頻率		1000 Hz			
Operating voltage / 工作電壓		DC 12 ~ 30V			
Current consumption / 消耗電流		≤ 8 mA no-load / 無負載 8mA 以下			
Load current / 負載電流		100 mA Max. at DC 24V			
Residual voltage / 殘餘電壓		≤ DC 1.5V			
Insulation resistance / 隔離阻抗		20M Ω min. (DC500V)			
Voltage withstandability / 絕緣耐壓		AC1000V 60Hz for 60 Sec.			
Operating temperature / 工作溫度		-20°C ~ + 60°C			
Protection degree / 防水等級		IP 66			
Option / 選購配件		M84R-2M-PVC / M84RL-2M PVC			
Wiring method / 出線方式		Pre-wire Ø3x2M / 3 wires	M8 pigtailed type/ M8接頭15cm電線式	Pre-wire Ø3x2M / 3 wires	M8 pigtailed type/ M8接頭15cm電線式
Weight / 重量		26g	7.5g	26g	7.5g
<b>Wiring diagrams / 接線圖</b>					
<b>-N</b>					
<b>-P</b>					

# 方形電感式近接開關

# Rectangular Inductive Proximity Sensor

## Characteristic / 特點：

- N3/P3 model : NPN N.O./N.C. & PNP N.O./N.C. 2-in-1 outputs.  
/ N3/P3電路：NPN N.O./N.C. & PNP N.O./N.C. 2合1輸出。
- Surge suppressor and overload protection .  
/ 突波吸收，負載保護。
- Compact and durable.  
/ 金屬外殼，堅固耐用。
- Single screw hole fixing.  
/ 單螺絲方便固定。



JM/JMD

電感式一靜電容近接開關

Ø3  
Ø4  
M5  
Ø6  
M8  
M12  
M18  
M30

JM  
JN  
KND  
PN  
PND  
RN  
SN

SID  
SIR  
SIA

KC  
KCT  
KCP

Model / 型號	NPN N.O. / N.C.	JM04-N3	JM04-N3B	JMD04-N3	JMD04-N3B
	PNP N.O. / N.C.	JM04-P3	JM04-P3B	JMD04-P3	JMD04-P3B
Sensing distance / 檢出距離	4 mm ±10%				
Secure sensing distance / 建議距離	0 ~3.2 mm				
Standard sensing object / 標準檢測物	Iron / 鐵 12 × 12 × 1mm				
Sensing type / 檢出方式	Top surface / 前方		Front surface / 上方		
Hysteresis / 遲滯	≤ 10 % of sensing distance / 檢測距離的 10 %以下				
Response time / 反應頻率	700 Hz				
Operating voltage / 工作電壓	DC 12 ~ 30V				
Current consumption / 消耗電流	≤ 8 mA no-load / 無負載 8mA 以下				
Load current / 負載電流	100 mA Max. at DC 24V				
Residual voltage / 殘餘電壓	≤ DC 1.5V				
Insulation resistance / 隔離阻抗	20M Ω min. (DC500V)				
Voltage withstandability / 絕緣耐壓	AC1000V 60Hz for 60 Sec.				
Operating temperature / 工作溫度	-20°C ~ + 60°C				
Protection degree / 防水等級	IP 66				
Option / 選購配件	M84R-2M-PVC / M84RL-2M PVC				
Wiring method / 出線方式	Pre-wire Ø3x2M / 3 wires	M8 pigtailed type/ M8接頭15cm電線式	Pre-wire Ø3x2M / 3 wires	M8 pigtailed type/ M8接頭15cm電線式	M8 pigtailed type/ M8接頭15cm電線式
Weight / 重量	26g	7.5g	26g	7.5g	7.5g
<b>Wiring diagrams / 接線圖</b>					
<b>-N3</b>					
<b>-P3B</b>					

## Characteristic / 特點：

- Small dimension: 8.5x5.5x25mm.  
/ 尺寸迷你，僅8.5x5.5x25mm。
- Front / Upside sensing available.  
/ 規格齊全：前方感應、上方感應。
- Single screw hole fixing.  
/ 單螺絲方便固定。

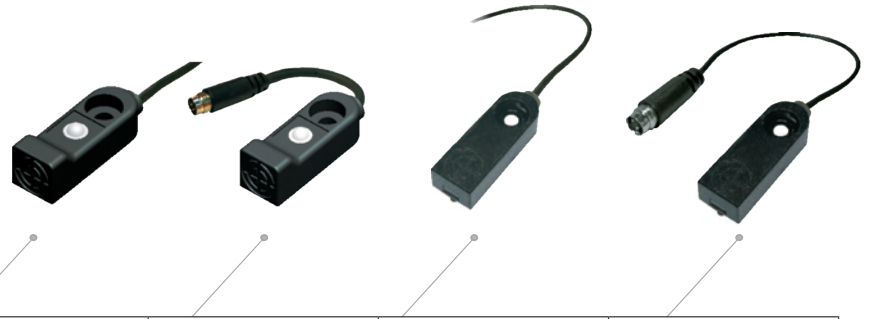

Model / 型號	NPN N.O.	JN02-N	JN02-NB	JND02-N	JND02-NB
	PNP N.O.	JN02-P	JN02-PB	JND02-P	JND02-PB
	DC 2 線式 N.O.	JN02-C	-	JND02-C	-
	DC 2 線式 N.C.	JN02-C2	-	JND02-C2	-
Sensing distance / 檢出距離	2 mm ±10%				
Secure sensing distance / 建議距離	0 ~ 1.6 mm				
Standard sensing object / 標準檢測物	Iron / 鐵 8 x 8 x 1mm				
Sensing surface / 檢測方向	Top surface / 前方		Front surface / 上方		
Hysteresis / 遲滯	≤ 10 % of sensing distance / 檢測距離的 10 % 以下				
Response time / 反應頻率	1000 Hz				
Operating voltage / 工作電壓	DC 12 ~ 30V / DC24V ± 10%				
Current consumption / 消耗電流	≤ 8 mA no-load / (Not for C/C2)				
Load current / 負載電流	100 mA Max. at DC 30V 100 mA Max. at DC 24V				
Residual voltage / 殘餘電壓	≤ DC 1.5V / ≤ DC 7V				
Insulation resistance / 隔離阻抗	20M Ω min. (DC500V)				
Voltage withstandability / 絕緣耐壓	AC1000V 60Hz for 60 Sec.				
Operating temperature / 工作溫度	-20 °C ~ + 60 °C				
Protection degree / 防水等級	IP 64				
Option / 選購配件	M84R-2M-PVC / M84RL-2M PVC				
Wiring method / 出線方式	Pre-wire Ø3x2M/3 wires C/C2 : Ø3x2M/2 wires	M8 pigtailed type/ M8接頭15cm電線式	Pre-wire Ø3x2M/3 wires C/C2 : Ø3x2M/2 wires	M8 pigtailed type/ M8接頭15cm電線式	
Weight / 重量	30g	10g	28g	10g	
<b>Wiring diagrams / 接線圖</b>					
<b>-N</b>					
<b>-PB</b>					
<p>(1) BROWN (3) BLUE (2) WHITE (4) BLACK</p>					

# 方形電感式近接開關

# Rectangular Inductive Proximity Sensor

## Characteristic / 特點：

- N3/P3 model : NPN N.O./N.C. & PNP N.O./N.C. 2-in-1 outputs.  
/ N3/P3 電路：NPN N.O./N.C. & PNP N.O./N.C. 2合1輸出。
- Surge suppressor and overload protection .  
/ 突波吸收，負載保護。
- Front / Upside sensing available.  
/ 規格齊全：前方感應、上方感應。
- Single screw hole fixing.  
/ 單螺絲方便固定。



Model / 型號	NPN N.O. / N.C.	JN04-N3	JN04-N3B	JND04-N3	JND04-N3B
	PNP N.O. / N.C.	JN04-P3	JN04-P3B	JND04-P3	JND04-P3B
	DC 2 線式 N.O.	JN04-C	-	JND04-C	-
	DC 2 線式 N.C.	JN04-C2	-	JND04-C2	-
Sensing distance / 檢出距離	4 mm ±10%				
Secure sensing distance / 建議距離	0 ~ 3.2 mm				
Standard sensing object / 標準檢測物	Iron / 鐵 8 x 8 x 1mm				
Sensing surface / 檢測方向	Top surface / 前方		Front surface / 上方		
Hysteresis / 遲滯	≤ 10 % of sensing distance / 檢測距離的 10 %以下				
Response time / 反應頻率	1000 Hz				
Operating voltage / 工作電壓	DC 12 ~ 30V / DC24V±10%				
Current consumption / 消耗電流	≤ 8 mA no-load / (Not for C/C2)				
Load current / 負載電流	100 mA Max. at DC 24V				
Residual voltage / 殘餘電壓	≤ DC 1.5V / DC 7V				
Insulation resistance / 隔離阻抗	最小 20M Ω (DC500V)				
Voltage withstandability / 絕緣耐壓	AC1000V 60Hz for 60 Sec.				
Operating temperature / 工作溫度	-20°C ~ + 60°C				
Protection degree / 防水等級	IP 64				
Option / 選購配件	M84R-2M-PVC / M84RL-2M PVC				
Wiring method / 出線方式	Pre-wire Ø3x2M/3 wires C/C2 : Ø3x2M/2 wires	M8 pigtailed type/ M8接頭15cm電線式	Pre-wire Ø3x2M/3 wires C/C2 : Ø3x2M/2 wires	M8 pigtailed type/ M8接頭15cm電線式	
Weight / 重量	26g	6g	26g	6g	
<b>Wiring diagrams / 接線圖</b>					
<b>-N3</b>					
<b>-P3B</b>					

JN/JND

電感式一靜電容近接開關

Ø3  
Ø4  
M5  
Ø6  
M8  
M12  
M18  
M30

JM  
JN  
KND  
PN  
PND  
RN  
SN

SID  
SIR  
SIA

KC  
KCT  
KCP

## Characteristic / 特點：

- The IP67 rating is designed to the effective waterproof.  
/ 保護結構達到 IP67 的規格，能有效的防水。
- Body-hole type is easy to installation, anyone can replace the new sensor in a minute.  
/ 自帶安裝孔，安裝更換很容易。
- Small size (25 X 8 X 7.4mm), so can well mounted in narrow space.  
/ 體積微小 (25 X 8 X 7.4mm)，可在狹小的空間安裝。
- DC 2-wire output model available.  
/ DC 二線式輸出，省配線。



KND

電感式 - 靜電容近接開關

Ø3  
Ø4  
M5  
Ø6  
M8  
M12  
M18  
M30

JM  
JN  
KND  
PN  
PND  
RN  
SN

SID  
SIR  
SIA

KC  
KCT  
KCP

Model / 型號	NPN N.O.	KND02-N	-
	NPN N.C.	KND02-N2	-
	PNP N.O.	KND02-P	-
	PNP N.C.	KND02-P2	-
	2 線式 N.O.		KND02-C
	2 線式 N.C.		KND02-C2
Sensing distance / 檢出距離	2.5 mm ±10%		
Secure sensing distance / 建議距離	0 ~ 1.8mm		
Standard sensing object / 標準檢測物	Iron / 鐵 15 x 15 x 1.5mm		
Sensing surface / 檢測方向	Front surface / 上方		
Hysteresis / 遲滯	≤10% of sensing distance / 檢測距離的 10% 以下		
Response time / 反應頻率	1000 Hz		
Operating voltage / 工作電壓	DC 10 ~ 30V	DC 24V ± 10%	
Current consumption / 消耗電流	≤8 mA no-load	-	
Output current / 輸出電流	100 mA Max. at DC 24V		
Residual voltage / 殘餘電壓	≤ DC 1.5V	≤ DC 7V	
Insulation resistance / 隔離阻抗	50M Ω min. (DC500V)		
Voltage withstandability / 絕緣耐壓	AC1000V 60Hz for 60 Sec.		
Operating temperature / 工作溫度	-20°C ~ +60°C		
Protection degree / 防水等級	IP67		
Wiring method / 出線方式	Pre-wired Ø3 x 2M / 3 wires	Pre-wired Ø3 x 2M / 2 wires	
Weight / 重量	15g		

## Wiring diagrams / 接線圖

-N

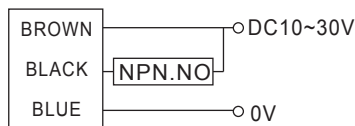

-P

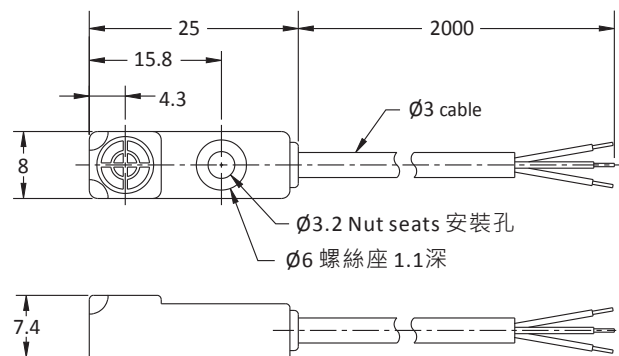
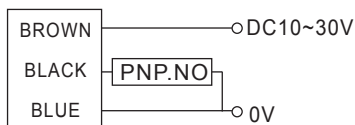

# 耐彎抗拉方形電感式近接開關

# Rectangular Inductive Proximity Sensor

## Characteristic / 特點：

- 1/2 smaller dimension than old models.  
/ 尺寸迷你，僅傳統型的1/2體積。
- Dual LED motion indicators.  
/ 雙LED動作指示燈。
- DC 2-wire output model available.  
/ DC二線式輸出，省配線。
- N3/P3 model : NPN N.O./N.C. & PNP N.O./N.C. 2-in-1 outputs.  
/ N3/P3電路：NPN N.O./N.C. & PNP N.O./N.C. 2合1輸出。
- Surge suppressor and overload protection .  
/ 突波吸收，負載保護。



Model / 型號	NPN N.O. / N.C.	PN05-N3	PN05-N3B
	PNP N.O. / N.C.	PN05-P3	PN05-P3B
	2 線式 N.O.	PN05-C	-
	2 線式 N.C.	PN05-C2	-
Sensing distance / 檢出距離	5mm ±10%		
Secure sensing distance / 建議距離	0 ~ 4 mm		
Standard sensing object / 標準檢測物	Iron / 鐵 18 x 18 x 1mm		
Sensing surface / 檢測方向	Top surface / 前方		
Hysteresis / 遲滯	≤10% of sensing distance / 檢測距離的 10 %以下		
Response time / 反應頻率	500 Hz		
Operating voltage / 工作電壓	DC 12 ~ 30V / DC 24V ± 10%		
Current consumption / 消耗電流	≤ 8 mA no-load / (Not for C/C2)		
Load current / 負載電流	100 mA Max. at DC 24V		
Leakage current / 漏電流	≤1.1 mA no-load / ≤0.7 mA no-load		
Residual voltage / 殘餘電壓	≤ DC 1.5V / ≤ DC 7V		
Insulation resistance / 隔離阻抗	20M Ω min. (DC500V)		
Voltage withstandability / 絕緣耐壓	AC1000V 60Hz for 60 Sec.		
Operating temperature / 工作溫度	-20°C ~ +60°C		
Protection degree / 防水等級	IP67		
Option / 選購配件	M84R-2M-PVC / M84RL-2M PVC PN05-M001,002		
Wiring method / 出線方式	Ø4.2 x 2M / 4 wires Ø4.2 x 2M / 2 wires	M8 pigtailed type / M8-4Pin出線式接頭型	
Weight / 重量	60g	20g	

## Dimensions / 尺寸圖 (mm)

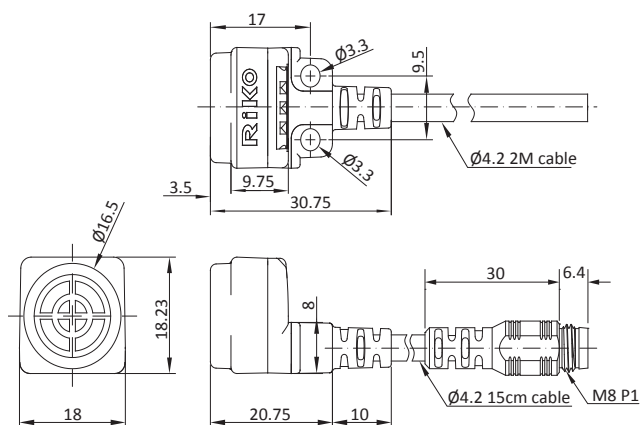

## Wiring diagrams / 接線圖

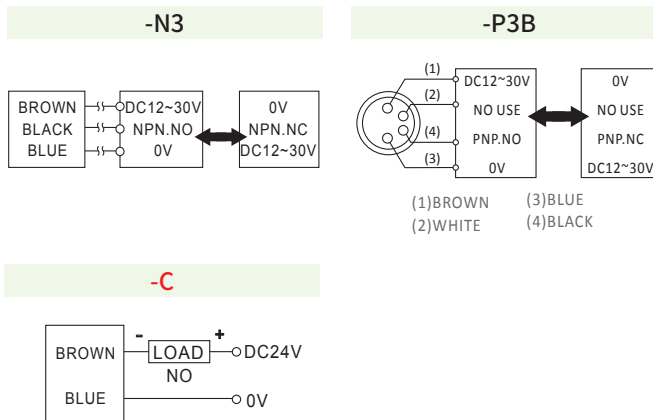

PN

電感式一靜電容近接開關

Ø3  
Ø4  
M5  
Ø6  
M8  
M12  
M18  
M30

JM  
JN  
KND  
PN  
PND  
RN  
SN

SID  
SIR  
SIA

KC  
KCT  
KCP

## Characteristic / 特點：

- 1/2 smaller dimension than old models.  
/ 尺寸迷你，僅傳統型的1/2體積。
- Dual LED motion indicators.  
/ 雙LED動作指示燈。
- Protection rating IP67.  
/ IP67防水等級。
- N3/P3 model : NPN N.O./N.C. & PNP N.O./N.C. 2-in-1 outputs.  
/ N3/P3 電路：NPN N.O./N.C. & PNP N.O./N.C. 2合1輸出。
- Surge suppressor and overload protection .  
/ 突波吸收，負載保護。



Model / 型號	NPN N.O. / N.C.	PN10-N3	PN15-N3	PN10-N3K	PN15-N3K
	PNP N.O. / N.C.	PN10-P3	PN15-P3	PN10-P3K	PN15-P3K
Sensing distance / 檢出距離		10 mm ±10%	15 mm ±10%	10 mm ±10%	15 mm ±10%
Secure sensing distance / 建議距離		0 ~ 8 mm	0 ~ 12 mm	0 ~ 8 mm	0 ~ 12 mm
Standard sensing object / 標準檢測物	Iron / 鐵 30 x 30 x 1mm				
Sensing surface / 檢測方向	Top surface / 前方				
Hysteresis / 遲滯	≤ 10 % of sensing distance / 檢測距離的 10 % 以下				
Response time / 反應頻率	300 Hz				
Operating voltage / 工作電壓	DC 12 ~ 30V				
Current consumption / 消耗電流	≤ 16 mA no-load				
Load current / 負載電流	100 mA Max. at DC 24V				
Residual voltage / 殘餘電壓	≤ DC 1.5V				
Insulation resistance / 隔離阻抗	20M Ω min. (DC500V)				
Voltage withstandability / 絕緣耐壓	AC1000V 60Hz for 60 Sec.				
Operating temperature / 工作溫度	-20 °C ~ + 60 °C				
Protection degree / 防水等級	IP 67				
Wiring method / 出線方式	Ø5.2 x 2M / 4 wires		M12 pigtailed type / M12 出線式接頭型		
Option / 選購配件	Bracket / 固定架：PN10-M001 / PN10-M002 M124R-PVC-2M				
Weight / 重量			92g		40g

## Dimensions / 尺寸圖 (mm)

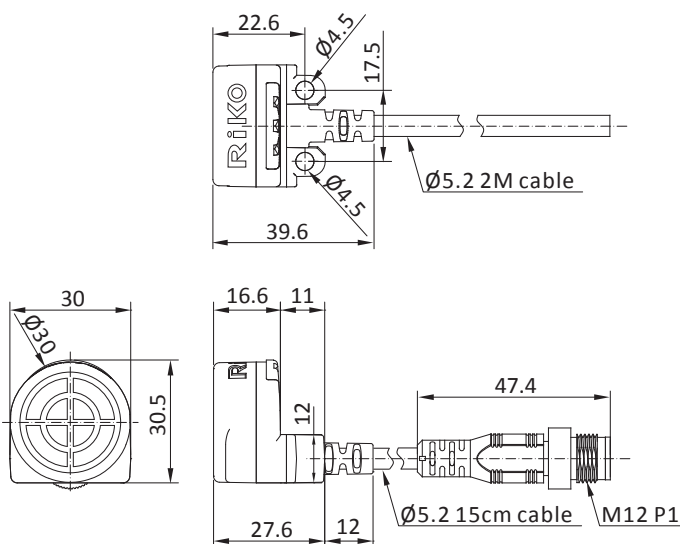

## Wiring diagrams / 接線圖

### -N3



### -P3K

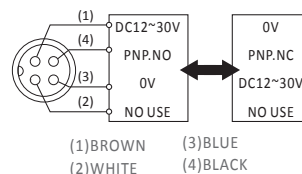

PN

電感式 - 靜電容近接開關

Ø3  
Ø4  
M5  
Ø6  
M8  
M12  
M18  
M30

JM  
JN  
KND  
PN  
PND  
RN  
SN

SID  
SIR  
SIA

KC  
KCT  
KCP

# 耐彎抗拉方形電感式近接開關

# Rectangular Inductive Proximity Sensor

## Characteristic / 特點：

- 1/2 smaller dimension than old models.  
/ 尺寸迷你，僅傳統型的1/2體積。
- Dual LED motion indicators.  
/ 雙LED動作指示燈。
- Protection rating IP67.  
/ IP67防水等級。
- N3/P3 model : NPN N.O./N.C. & PNP N.O./N.C. 2-in-1 outputs.  
/ N3/P3 電路：NPN N.O./N.C. & PNP N.O./N.C. 2合1輸出。
- Surge suppressor and overload protection .  
/ 突波吸收，負載保護。



Model / 型號	NPN N.O. / N.C.	PN20-N3	PN25-N3	PN20-N3K	PN25-N3K
	PNP N.O. / N.C.	PN20-P3	PN25-P3	PN20-P3K	PN25-P3K
Sensing distance / 檢出距離		20 mm ±10%	25 mm ±10%	20 mm ±10%	25 mm ±10%
Secure sensing distance / 建議距離		0 ~ 16 mm	0 ~ 20 mm	0 ~ 16 mm	0 ~ 20 mm
Standard sensing object / 標準檢測物	Iron / 鐵 40 x 40 x 1mm				
Sensing surface / 檢測方向	Top surface / 前方				
Hysteresis / 遲滯	≤ 10 % of sensing distance / 檢測距離的 10 % 以下				
Response time / 反應頻率	50 Hz				
Operating voltage / 工作電壓	DC 12 ~ 30V				
Current consumption / 消耗電流	≤ 16 mA no-load				
Load current / 負載電流	100 mA Max. at DC 24V				
Residual voltage / 殘餘電壓	≤ DC 1.5V				
Insulation resistance / 隔離阻抗	20M Ω min. (DC500V)				
Voltage withstandability / 絕緣耐壓	AC1000V 60Hz for 60 Sec.				
Operating temperature / 工作溫度	-20 °C ~ + 60°C				
Protection degree / 防水等級	IP 67				
Wiring method / 出線方式	Ø5.2 x 2M / 4 wires		M12 pigtailed type / M12 出線式接頭型		
Option / 選購配件	Bracket / 固定架：PN20-M001 / PN20-M002 M124R-PVC-2M				
Weight / 重量	128g		80g		

## Dimensions / 尺寸圖 (mm)

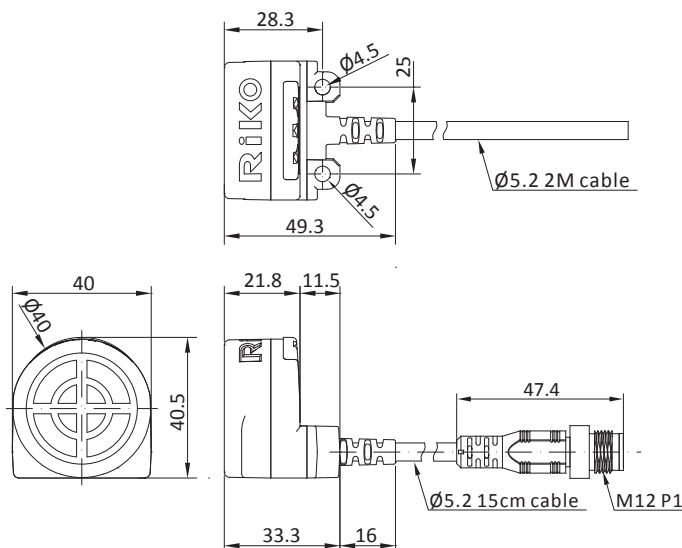

## Wiring diagrams / 接線圖

### -N3

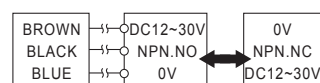

### -P3K

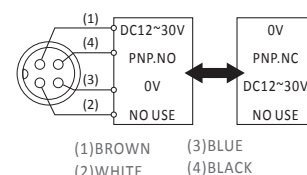

PN

電感式一靜電容近接開關

Ø3  
Ø4  
M5  
Ø6  
M8  
M12  
M18  
M30

JM  
JN  
KND

PN  
PND  
RN  
SN

SID  
SIR  
SIA

KC  
KCT  
KCP

## Characteristic / 特點：

- Anti-bending connection design.  
/ 包覆設計，耐彎保護。
- Saving space for installation.  
/ 體積薄，安裝省空間。
- Bright dual LED indicator.  
/ 清晰易見雙LED動作指示燈。
- N3/P3 model : NPN N.O./N.C. & PNP N.O./N.C. 2-in-1 outputs.  
/ N3/P3 電路：NPN N.O./N.C. & PNP N.O./N.C. 2合1輸出。
- Surge suppressor and overload protection.  
/ 突波吸收，負載保護。



Model / 型號	NPN N.O. / N.C.	PND04-N3	PND04-N3B
	PNP N.O. / N.C.	PND04-P3	PND04-P3B
	DC 2 線式 N.O.	PND04-C	-
	DC 2 線式 N.C.	PND04-C2	-
Sensing distance / 檢出距離	4mm ±10%		
Secure sensing distance / 建議距離	0 ~ 3.2 mm		
Standard sensing object / 標準檢測物	Iron / 鐵 18 x 18 x 1mm		
Sensing surface / 檢測方向	Front surface / 上方		
Hysteresis / 遲滯	≤10% of sensing distance / 檢測距離的 10 % 以下		
Response time / 反應頻率	500 Hz		
Operating voltage / 工作電壓	DC 12 ~ 30V / DC 24V ± 10%		
Current consumption / 消耗電流	≤14 mA no-load / (Not for C/C2)		
Load current / 負載電流	100 mA Max. at DC 24V		
Residual voltage / 殘餘電壓	≤ DC 1.5V / ≤ DC 7V		
Insulation resistance / 隔離阻抗	20M Ω min. (DC500V)		
Voltage withstandability / 絕緣耐壓	AC1000V 60Hz for 60 Sec.		
Operating temperature / 工作溫度	-20°C ~ +60°C		
Protection degree / 防水等級	IP67		
Option / 選購配件	M84R-2M-PVC / M84RL-2M PVC		
Wiring method / 出線方式	NP : Ø4.2x2M / 4 wires C/C2 : Ø4.2x2M / 2 wires	M8 pigtailed type / M8-4Pin出線式接頭型	
Weight / 重量	55g	15g	

## Dimensions / 尺寸圖 (mm)

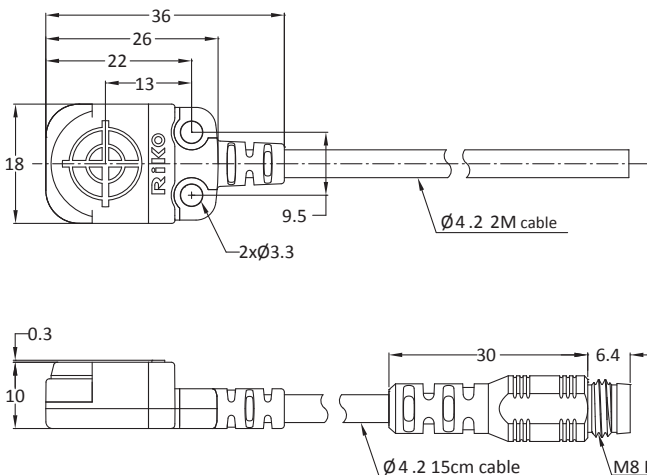

## Wiring diagrams / 接線圖

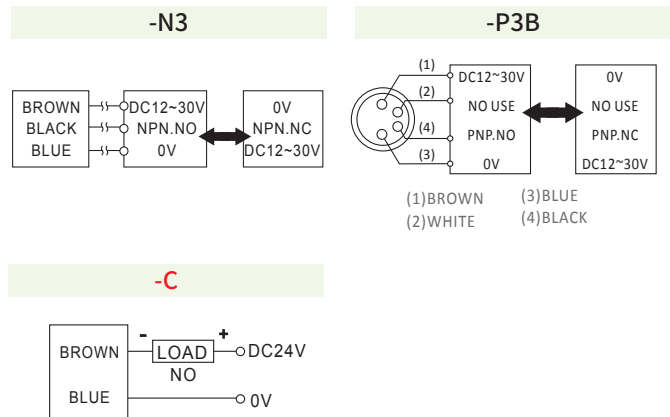

PND

電感式 - 靜電容近接開關

Ø3  
Ø4  
M5  
Ø6  
M8  
M12  
M18  
M30

JM  
JN  
KND  
PN  
PND  
RN  
SN

SID  
SIR  
SIA

KC  
KCT  
KCP

# 耐彎抗拉方形電感式近接開關

# Rectangular Inductive Proximity Sensor

## Characteristic / 特點：

- Sensing distance up to 16mm.  
/ 長距離感應16mm。
- Flat, front-side sensing, saving space.  
/ 扁型，上方感應，省空間。
- N3/P3 model : NPN N.O./N.C. & PNP N.O./N.C. 2-in-1 outputs.  
/N3/P3 電路：NPN N.O./N.C. & PNP N.O./N.C. 2合1輸出。
- Surge suppressor and overload protection .  
/ 突波吸收，負載保護。



Model / 型號	NPN N.O. / N.C.	PND16-N3	PND16-N3K1
	PNP N.O. / N.C.	PND16-P3	PND16-P3K1
Sensing distance / 檢出距離	16 mm ±10%		
Secure sensing distance / 建議距離	0 ~ 12.8mm		
Standard sensing object / 標準檢測物	Iron / 鐵 30 x 30 x 1mm		
Sensing surface / 檢測方向	Front surface / 上方		
Hysteresis / 遲滯	≤10% of sensing distance / 檢測距離的 10 %以下		
Response time / 反應頻率	250 Hz		
Operating voltage / 工作電壓	DC 12 ~ 30V		
Current consumption / 消耗電流	≤14 mA no-load		
Load current / 負載電流	100 mA Max. at DC 30V		
Residual voltage / 殘餘電壓	≤ DC 2V		
Insulation resistance / 隔離阻抗	20M Ω min. (DC500V)		
Voltage withstandability / 絕緣耐壓	AC1000V 60Hz for 60 Sec.		
Operating temperature / 工作溫度	-20°C ~ +60°C		
Protection degree / 防水等級	IP66		
Option / 選購配件	M124R-PVC-2M		
Wiring method / 出線方式	N/P : Ø5.2 x 2M / 3 wires	M12 connector / M12 出線式接頭型	
Weight / 重量	106g	36g	

PND

電感式一靜電容近接開關

Ø3  
Ø4  
M5  
Ø6  
M8  
M12  
M18  
M30

JM  
JN  
KND  
PN  
PND  
RN  
SN

SID  
SIR  
SIA

KC  
KCT  
KCP

## Dimensions / 尺寸圖 (mm)

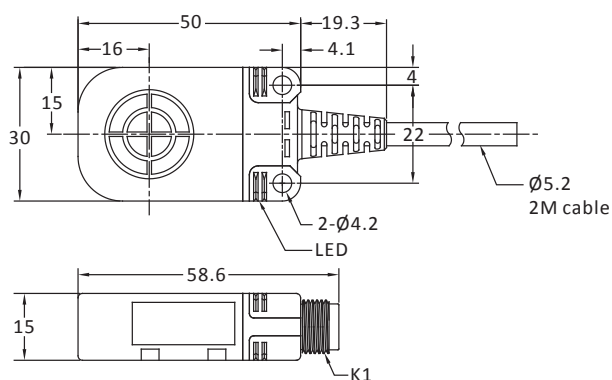

## Wiring diagrams / 接線圖

### -N3



### -P3K1

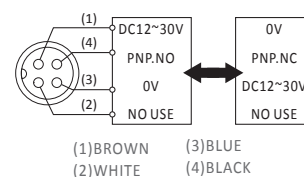

## PND16與周圍金屬的安全距離 (mm)

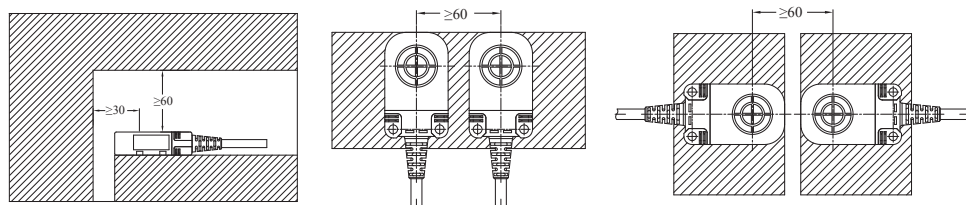

## Characteristic / 特點：

- The IP67 rating is designed to the effective waterproof.  
/ 保護結構達到IP67的規格，能有效的防水。
- Build-in twin LED, convenient for checking the operation.  
/ 具有雙LED，檢測操作更方便。
- Oval hole for easy installation and adjustment.  
/ 具有長形孔，可容易微調安裝。
- N3/P3 model : NPN N.O./N.C. & PNP N.O./N.C. 2-in-1 outputs.  
/ N3/P3電路：NPN N.O./N.C. & PNP N.O./N.C. 2合1輸出。
- Surge suppressor and overload protection .  
/ 突波吸收，負載保護。



RN

電感式 / 靜電容近接開關

Ø3  
Ø4  
M5  
Ø6  
M8  
M12  
M18  
M30

JM  
JN  
KND  
PN  
PND  
RN  
SN

SID  
SIR  
SIA

KC  
KCT  
KCP

Model / 型號	NPN N.O. / N.C.	RN04-N3	RN04-N3B1
	PNP N.O. / N.C.	RN04-P3	RN04-P3B1
Sensing distance / 檢出距離	5mm ±10%		
Secure sensing distance / 建議距離	0 ~ 4 mm		
Standard sensing object / 標準檢測物	Iron / 鐵 18 x 18 x 1mm		
Sensing surface / 檢測方向	Top surface / 前方		
Hysteresis / 遲滯	≤10% of sensing distance / 檢測距離的 10 %以下		
Response time / 反應頻率	500 Hz		
Operating voltage / 工作電壓	DC 12 ~ 30V		
Current consumption / 消耗電流	≤ 8 mA no-load / 無負載 8mA 以下		
Load current / 負載電流	100 mA Max. at DC 30V		
Residual voltage / 殘餘電壓	≤ DC 2V		
Insulation resistance / 隔離阻抗	20M Ω min. (DC500V)		
Voltage withstandability / 絕緣耐壓	AC1000V 60Hz for 60 Sec.		
Operating temperature / 工作溫度	-20°C ~ +60°C		
Protection degree / 防水等級	IP67		
Option / 選購配件	M84R-2M-PVC / M84RL-2M PVC		
Wiring method / 出線方式	Ø4.2 x 2M / 3 wires (線)	M8 connector / M8-4Pin 接頭型	
Weight / 重量	60g	12g	

## Dimensions / 尺寸圖 (mm)

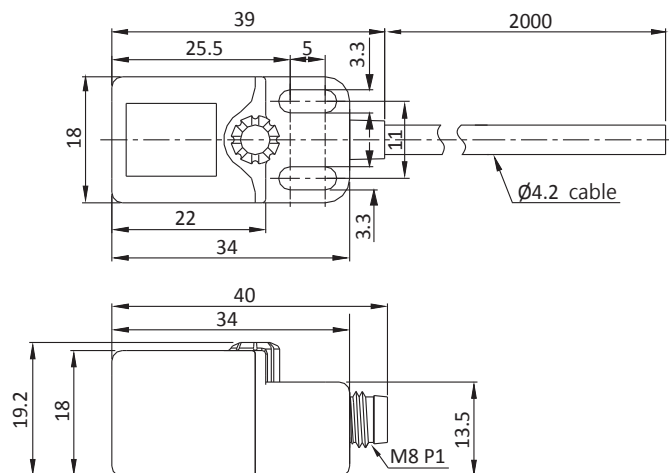

## Wiring diagrams / 接線圖

### -N3



### -P3B1

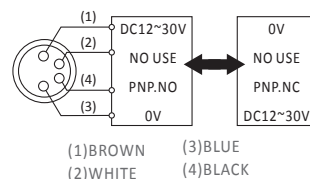

# 雙LED方形電感式近接開關

# Rectangular Inductive Proximity Sensor

## Characteristic / 特點：

- Build-in twin LED, convenient for checking the operation.  
/ 具有雙LED，檢測操作更方便。
- N3/P3 model : NPN N.O./N.C. & PNP N.O./N.C. 2-in-1 outputs.  
/ N3/P3 電路：NPN N.O./N.C. & PNP N.O./N.C. 2合1輸出。
- Surge suppressor and overload protection .  
/ 突波吸收，負載保護。



Model / 型號	NPN N.O. / N.C.	RN05-N3	RN05-N3B1
	PNP N.O. / N.C.	RN05-P3	RN05-P3B1
Sensing distance / 檢出距離	5mm ±10%		
Secure sensing distance / 建議距離	0 ~ 4 mm		
Standard sensing object / 標準檢測物	Iron / 鐵 18 x 18 x 1mm		
Sensing surface / 檢測方向	Top surface / 前方		
Hysteresis / 遲滯	≤10% of sensing distance / 檢測距離的 10%以下		
Response time / 反應頻率	500 Hz		
Operating voltage / 工作電壓	DC 12 ~ 30V		
Current consumption / 消耗電流	≤8 mA no-load		
Load current / 負載電流	150 mA		
Residual voltage / 殘餘電壓	≤ DC 1.5V		
Insulation resistance / 隔離阻抗	20M Ω min. (DC500V)		
Voltage withstandability / 絕緣耐壓	AC1000V 60Hz for 60 Sec.		
Operating temperature / 工作溫度	-20°C ~ +60°C		
Protection degree / 防水等級	IP64		
Option / 選購配件	M84R-2M-PVC / M84RL-2M PVC		
Wiring method / 出線方式	N/P : Ø4.2 x 2M / 3 wires	M8 connector / M8-4Pin 接頭型	
Weight / 重量	60g	12g	

## Dimensions / 尺寸圖 (mm)

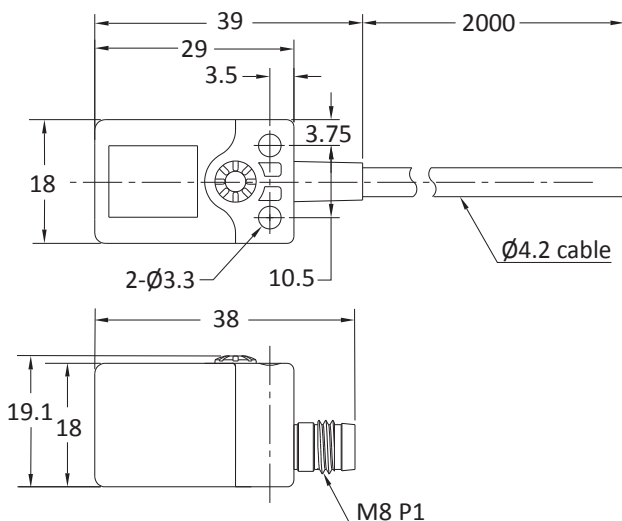

## Wiring diagrams / 接線圖

### -N3



### -P3B1

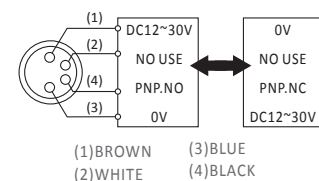

RN

電感式 - 靜電容近接開關

Ø3  
Ø4  
M5  
Ø6  
M8  
M12  
M18  
M30

JM  
JN  
KND  
PN  
PND  
RN  
SN

SID  
SIR  
SIA

KC  
KCT  
KCP

## Characteristic / 特點：

- Flat, front-side sensing, saving space.  
/ 扁型，上方感應，不占空間。
- Surge suppressor and overload protection.  
/ 突波吸收，負載保護。
- N3/P3 model : NPN N.O./N.C. & PNP N.O./N.C. 2-in-1 outputs.  
/ N3/P3 電路：NPN N.O./N.C. & PNP N.O./N.C. 2合1輸出。



Model / 型號	NPN N.O. / N.C.	SND04-N3	SND04-N3B
	PNP N.O. / N.C.	SND04-P3	SND04-P3B
Sensing distance / 檢出距離	4 mm ±10%		
Secure sensing distance / 建議距離	0 ~ 3.2 mm		
Standard sensing object / 標準檢測物	Iron / 鐵 18 x 18 x 1mm		
Sensing surface / 檢測方向	Front surface / 上方		
Hysteresis / 遲滯	≤ 10 % of sensing distance / 檢測距離的 10 % 以下		
Response time / 反應頻率	500 Hz		
Operating voltage / 工作電壓	DC 12 ~ 30V		
Current consumption / 消耗電流	≤ 8 mA no-load		
Load current / 負載電流	100 mA Max. at DC 30V		
Residual voltage / 殘餘電壓	≤ DC 1.5V		
Insulation resistance / 隔離阻抗	20MΩ min. (DC500V)		
Voltage withstandability / 絕緣耐壓	AC1000V 60Hz for 60 Sec.		
Operating temperature / 工作溫度	-20°C ~ +60°C		
Protection degree / 防水等級	IP 66		
Option / 選購配件	M84R-2M-PVC / M84RL-2M PVC		
Wiring method / 出線方式	Pre-wired Ø4.2 x 2M / 3 wires		M8 pigtailed type / M8 出線式接頭型
Weight / 重量	60g		18g
<b>Wiring diagrams / 接線圖</b>			
<p><b>-N3</b></p>			
<p><b>-P3B1</b></p> <p>(1) BROWN (3) BLUE (2) WHITE (4) BLACK</p>			

# 方形電感式近接開關

# Rectangular Inductive Proximity Sensor

## Characteristic / 特點：

- N3/P3 model : NPN N.O./N.C. & PNP N.O./N.C. 2-in-1 outputs.  
/ N3/P3 電路：NPN N.O./N.C. & PNP N.O./N.C. 2合1輸出。
- Large LED indicator, Clearly checking working operation.  
/ 大面積動作燈，可清晰了解感測器的動作。
- Surge suppressor and overload protection.  
/ 突波吸收，負載保護。
- Applications for limit positioning, counting control.  
/ 最適合用於極限定位、計數控制。
- Sensing distance up to 10mm.  
/ 檢測距離10mm，檢出更穩定。



Model / 型號	NPN N.O. / N.C.	SN10-N3	SN10-N3K
	PNP N.O. / N.C.	SN10-P3	SN10-P3K
Sensing distance / 檢出距離	10 mm ±10%		
Secure sensing distance / 建議距離	0 ~ 8 mm		
Standard sensing object / 標準檢測物	Iron / 鐵 30 x 30 x 1mm		
Sensing surface / 檢測方向	Top surface / 前方		
Hysteresis / 遲滯	≤ 10 % of sensing distance / 檢測距離的 10 %以下		
Response time / 反應頻率	300 Hz		
Operating voltage / 工作電壓	DC 12 ~ 30V		
Current consumption / 消耗電流	≤ 8 mA no-load		
Load current / 負載電流	100 mA Max. at DC 30V		
Residual voltage / 殘餘電壓	≤ DC 1.5V		
Insulation resistance / 隔離阻抗	20M Ω min. (DC500V)		
Voltage withstandability / 絕緣耐壓	AC1000V 60Hz for 60 Sec.		
Operating temperature / 工作溫度	-20 °C ~ + 60 °C		
Protection degree / 防水等級	IP 66		
Option / 選購配件	M124R-PVC-2M		
Wiring method / 出線方式	Pre-wired Ø5.2 x 2M / 3-wires	M12 pigtailed type / M12 出線式接頭型	
Weight / 重量	125g	70g	
<b>Wiring diagrams / 接線圖</b>			
<b>-N3</b>			
<b>-P3K</b>			
<p>(1) BROWN (3) BLUE (2) WHITE (4) BLACK</p>			

SN

電感式 / 靜電容近接開關

Ø3  
Ø4  
M5  
Ø6  
M8  
M12  
M18  
M30

JM  
JN  
KND  
PN  
PND  
RN  
SN

SID  
SIR  
SIA

KC  
KCT  
KCP

## Characteristic / 特點：

- N3/P3 model : NPN N.O./N.C. & PNP N.O./N.C. 2-in-1 outputs.  
/ N3/P3 電路：NPN N.O./N.C. & PNP N.O./N.C. 2合1輸出。
- Around two times longer sensing distance than conventional models.  
/ 檢測距離接近原有機型的兩倍。
- Short circuit protection / Revers polarity protection.  
/ 短路保護/極性保護裝置。
- Waterproof.  
/ 防水。

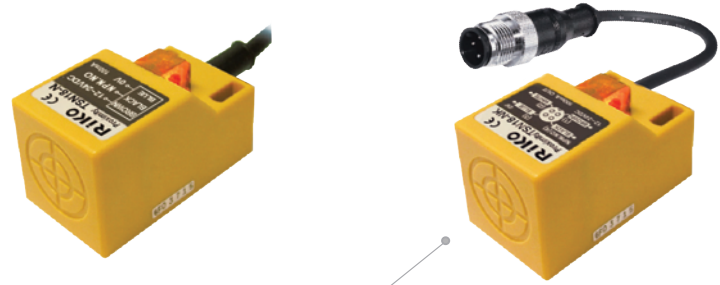

Model / 型號	NPN N.O. / N.C.	SN18-N3	SN18-N3K
	PNP N.O. / N.C.	SN18-P3	SN18-P3K
Sensing distance / 檢出距離	18 mm ± 10%		
Secure sensing distance / 建議距離	0 ~ 14.4 mm		
Standard sensing object / 標準檢測物	Iron / 鐵 30 x 30 x 1mm		
Sensing surface / 檢測方向	Top surface / 前方		
Hysteresis / 遲滯	≤ 15 % of sensing distance / 檢測距離的 15 % 以下		
Response time / 反應頻率	200 Hz		
Operating voltage / 工作電壓	DC 12 ~ 30V		
Current consumption / 消耗電流	≤ 12 mA no-load		
Load current / 負載電流	100 mA Max. at DC 24V		
Residual voltage / 殘餘電壓	≤ DC 1.5V		
Insulation resistance / 隔離阻抗	20MΩ min. (DC500V)		
Voltage withstandability / 絕緣耐壓	AC1000V 60Hz for 60 Sec.		
Operating temperature / 工作溫度	-5 °C ~ + 50 °C		
Protection degree / 防水等級	IP 66		
Option / 選購配件	M124R-PVC-2M		
Wiring method / 出線方式	Pre-wired Ø5.2 x 2M / 4 wires	M12 pigtailed type / M12 出線式接頭型	
Weight / 重量	125g	70g	
<b>Wiring diagrams / 接線圖</b>			
<b>-N3</b>			
<b>-P3K</b>			

NS

電感式一靜電容近接開關

Ø3  
Ø4  
M5  
Ø6  
M8  
M12  
M18  
M30

JM  
JN  
KND  
PN  
PND  
RN  
SN

SID  
SIR  
SIA

KC  
KCT  
KCP

# 方形電感式近接開關

# Rectangular Inductive Proximity Sensor

## Characteristic / 特點：

- N3/P3 model : NPN N.O./N.C. & PNP N.O./N.C. 2-in-1 outputs.  
/ N3/P3電路：NPN N.O./N.C. & PNP N.O./N.C. 2合1輸出。
- Large LED indicator, Clearly checking working operation.  
/ 大面積動作燈，可清晰了解感測器的動作。
- Surge suppressor and overload protection.  
/ 突波吸收，負載保護。
- Applications for limit positioning, counting control.  
/ 最適合用於極限定位、計數控制。
- Sensing distance up to 20mm.  
/ 檢測距離20mm，檢出更穩定。

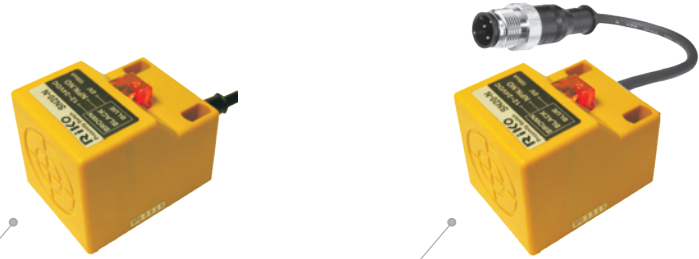

Model / 型號	NPN N.O. / N.C.	SN20-N3	SN20-N3K
	PNP N.O. / N.C.	SN20-P3	SN20-P3K
Sensing distance / 檢出距離	20 mm ±10%		
Secure sensing distance / 建議距離	0 ~ 16 mm		
Standard sensing object / 標準檢測物	Iron / 鐵 40 x 40 x 1mm		
Sensing surface / 檢測方向	Top surface / 前方		
Hysteresis / 遲滯	≤ 10 % of sensing distance / 檢測距離的 10 % 以下		
Response time / 反應頻率	50 Hz		
Operating voltage / 工作電壓	DC 12 ~ 30V		
Current consumption / 消耗電流	≤ 8 mA no-load		
Load current / 負載電流	100 mA Max. at DC 30V		
Residual voltage / 殘餘電壓	≤ DC 1.5V		
Insulation resistance / 隔離阻抗	20M Ω min. (DC500V)		
Voltage withstandability / 絕緣耐壓	AC1000V 60Hz for 60 Sec.		
Operating temperature / 工作溫度	-20 °C ~ + 60°C		
Protection degree / 防水等級	IP 67		
Option / 選購配件	M124R-PVC-2M		
Wiring method / 出線方式	Pre-wired Ø5.2 x 2M / 3-wires	M12 pigtailed type / M12 出線式接頭型	
Weight / 重量	170g	118g	

## Wiring diagrams / 接線圖

### -N3

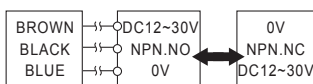

### -P3K

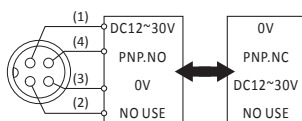

(1) BROWN (3) BLUE  
(2) WHITE (4) BLACK

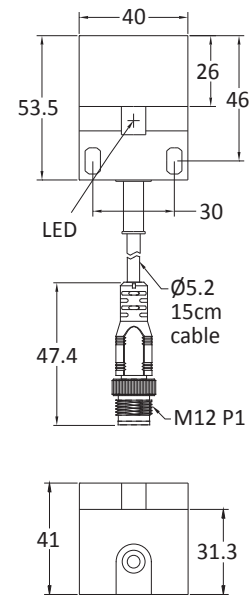
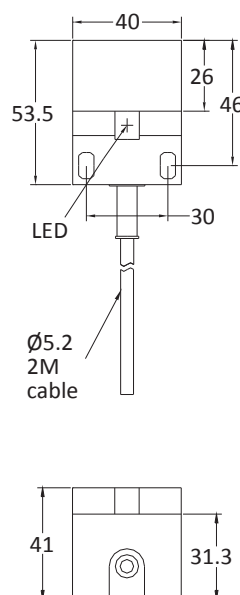

SN

電感式 / 靜電容近接開關

Ø3  
Ø4  
M5  
Ø6  
M8  
M12  
M18  
M30

JM  
JN  
KND  
PN  
PND  
RN  
SN

SID  
SIR  
SIA

KC  
KCT  
KCP

## Characteristic / 特點：

- N3/P3 model : NPN N.O./N.C. & PNP N.O./N.C. 2-in-1 outputs.  
/ N3/P3 電路：NPN N.O./N.C. & PNP N.O./N.C. 2合1輸出。
- Around two times longer sensing distance than conventional models.  
/ 檢測距離接近原有機型的兩倍。
- Short circuit protection / Revers polarity protection.  
/ 短路保護/極性保護裝置。
- Waterproof.  
/ 防水。

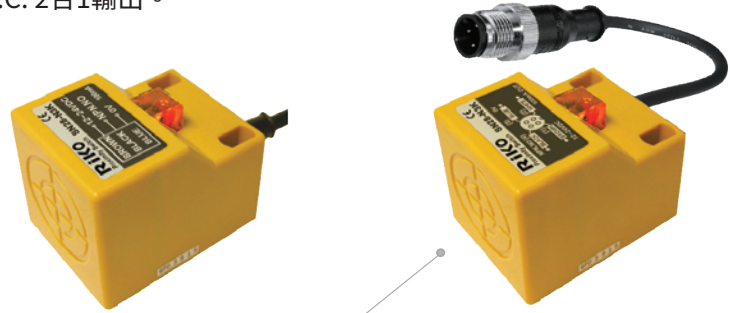

Model / 型號	NPN N.O. / N.C.	SN28-N3	SN28-N3K
	PNP N.O. / N.C.	SN28-P3	SN28-P3K
Sensing distance / 檢出距離	28 mm ± 10%		
Secure sensing distance / 建議距離	0 ~ 22.4 mm		
Standard sensing object / 標準檢測物	Iron / 鐵 40 x 40 x 1mm		
Sensing surface / 檢測方向	Top surface / 前方		
Hysteresis / 遲滯	≤ 15 % of sensing distance / 檢測距離的 15 % 以下		
Response time / 反應頻率	100 Hz		
Operating voltage / 工作電壓	DC 12 ~ 30V		
Current consumption / 消耗電流	≤ 12 mA no-load		
Load current / 負載電流	100 mA Max. at DC 24V		
Residual voltage / 殘餘電壓	≤ DC 1.5V		
Insulation resistance / 隔離阻抗	20MΩ min. (DC500V)		
Voltage withstandability / 絕緣耐壓	AC1000V 60Hz for 60 Sec.		
Operating temperature / 工作溫度	-5 °C ~ + 50 °C		
Protection degree / 防水等級	IP 66		
Option / 選購配件	M124R-PVC-2M		
Wiring method / 出線方式	Pre-wired Ø5.2 x 2M/4 wires		M12 pigtailed type / M12 出線式接頭型
Weight / 重量	170g		118g
<b>Wiring diagrams / 接線圖</b>			
<b>-N3</b>			
<b>-P3K</b>			

NS

電感式 - 靜電容近接開關

Ø3  
Ø4  
M5  
Ø6  
M8  
M12  
M18  
M30

JM  
JN  
KND  
PN  
PND  
RN  
SN

SID  
SIR  
SIA

KC  
KCT  
KCP

# 方形電感式近接開關

# Rectangular Inductive Proximity Sensor

## Precautions proper installation / 安裝注意事項

Influenced by surrounding metals. / 周圍金屬影響

避免環境干擾，請參照建議安裝距離表格如下

### SN 系列

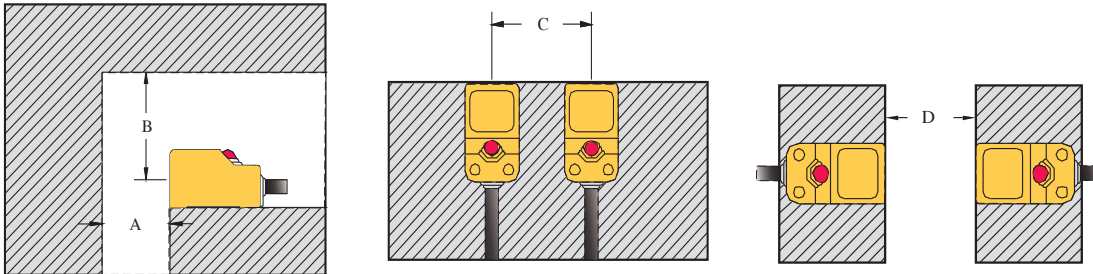

Model	A (mm)	B (mm)	C (mm)	D (mm)
SND04	≥ 15	≥ 20	≥ 30	≥ 30
RN04	≥ 15	≥ 20	≥ 30	≥ 30
RN05	≥ 20	≥ 25	≥ 40	≥ 40
SN10	≥ 40	≥ 30	≥ 60	≥ 60
SN20	≥ 80	≥ 45	≥ 80	≥ 80
SN18	≥ 72	≥ 54	≥ 180	≥ 180
SN28	≥ 112	≥ 63	≥ 280	≥ 280

### Around two times longer sensing distance than conventional models. / 檢測距離接近原有機型的兩倍

TSC series features 180% longer sensing distance than conventional models. It makes the detection more stable.

TSN系列比原有的機型檢測距提升了180%，使檢測更加可靠。

### SN10-□ (傳統模式)

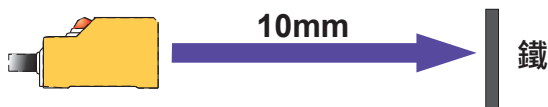

SN10-□ 10mm

SN20-□ 20mm



SN

電感式 - 靜電容近接開關

Ø3  
Ø4  
M5  
Ø6  
M8  
M12  
M18  
M30

JM  
JN  
KND  
PN  
PND  
RN  
SN

SID  
SIR  
SIA

KC  
KCT  
KCP

### Short Circuit Protection / Reverse Polarity Protection 短路保護/極性保護裝置

The TSC series will activate the short circuit protection / reverse polarity protection to reduce the damage caused by the wrong operation.

當使用者誤接輸出線或極性相反時，將會啟動短路保護/極性保護，以降低因誤接而所造成的損害。

### Waterproof / 防水

IP66 protection. The sensor can be installed outdoors. It can prevent damage caused by immersion or dip in water under regular standard.

防水等級為IP66，可裝置在室外，在一定標準下能確保不因浸水而造成損壞。

## Characteristic / 特點：

- Suitable for the detection of tiny metal passing.  
/ 適合檢測通過的微小金屬。
- The pigtailed type connector makes easy disconnection.  
/ 有端子式，讓您能夠迅速的更換。
- Digital sensitivity adjustment.  
/ 數字顯示，感測強度，可依據感測物大小而調整。
- Setting by +/- button.  
/ 感度可用(+)(-)鍵設定。
- Clear LED indicator.  
/ 側發光動作LED清晰可見。



SID

電感式 / 靜電容近接開關

Ø3  
Ø4  
M5  
Ø6  
M8  
M12  
M18  
M30

JM  
JN  
KND  
PN  
PND  
RN  
SN

SID  
SIR  
SIA

KC  
KCT  
KCP

Model / 型號	出線式 Ø5.2	SID05-KP2	SID10-KP2	SID15-KP2	SID22-KP2	SID30-KP2
	M12 出線式接頭型	SID05-KP2K1	SID10-KP2K1	SID15-KP2K1	SID22-KP2K1	SID30-KP2K1
Sensing hole diameter / 檢測孔直徑		D=5mm	D=10mm	D=15mm	D=22mm	D=30mm
Min. detecting object / 最小檢測物		0.8mm min.	1.2mm min.	2mm min.	3mm min.	5mm min.
Operating voltage / 工作電壓	DC 12 ~ 24V					
Current consumption / 消耗電流	30 mA					
Load current / 負載電流	100 mA Max. at DC 24V					
Output method / 輸出模式	NPN N.O./N.C. PNP N.C./N.O.					
Operating temperature / 工作溫度	-20°C ~ +60°C					
Protection degree / 防水等級	IP 64					
Option / 選購配件	M124R-PVC-2M					
Wiring method / 出線方式	SID-□KP2	Ø5.2 x 2M / 4-wires				
	SID-□KP2K1	M12 plug in connector type / M12 出線式接頭型				
Weight / 重量	SID-□KP2	100g	100g	100g	96g	92g
	SID-□KP2K1	32g	32g	32g	31g	28g

## Dimensions / 尺寸圖 (mm)

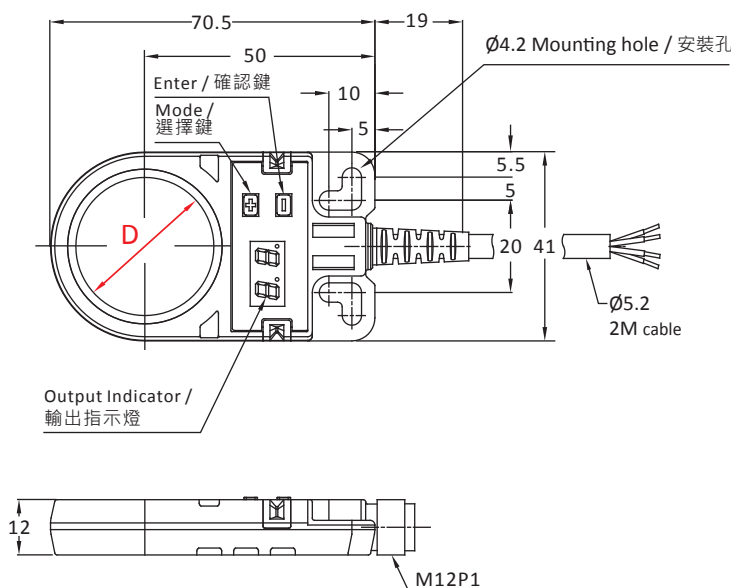

## Wiring diagrams / 接線圖

### -KP2

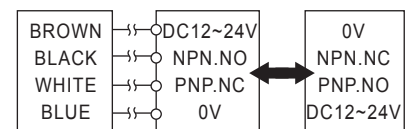

### -KP2K1

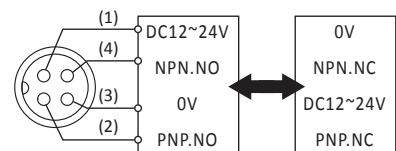

(1) BROWN (3) BLUE  
(2) WHITE (4) BLACK

## 感測器與金屬物質最小距離 (最小檢測物)

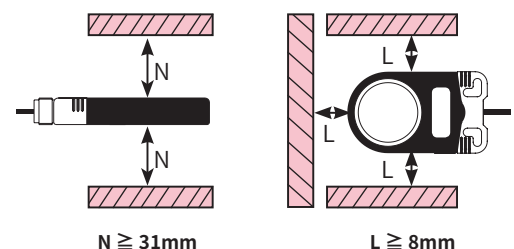

# 環形近接開關

# Ring Inductive Proximity Sensor

※ Press the + or - button , and the value will be auto teaching after the flashing. (the object needs to be placed in the induction coil.) / 需先按壓一下+或-鍵，數值閃爍後即可自動教導(被測物需放在感應線圈中)。

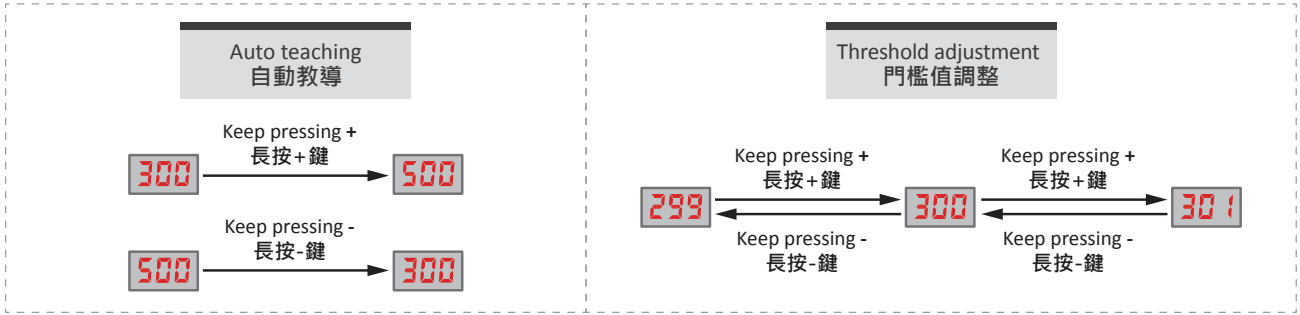

※ Press once + or - the threshold figures start flashing. / 需先按壓一下+或-鍵，數值閃爍後即可調整靈敏度。



When increasing the sensitivity adjustment, press the + button and the right indicator light "green" at the same time. / 增加靈敏度調整時，按壓+鍵，右指示燈"同時"閃綠燈。



When increasing the sensitivity adjustment, press the - button and the left indicator light "green" at the same time. / 增加靈敏度調整時，按壓-鍵，左指示燈"同時"閃綠燈。



Output action light: left and right indicator red light. / 輸出動作燈: 左右指示燈紅燈

During the adjustment process: When the +, - button is pressed, the value "not" flashes after "0.5" seconds, and the value is immediately increased or decreased. The button is released and the value is flashed "3" seconds. The value stops flashing after entering the current threshold.

- 調整過程中:當按壓一下+或-鍵時,數值"不"是"持續閃爍,但是"3"秒內(含)沒有按壓+或-鍵數值自動寫入當前門檻值且立即停止閃爍。
- 調整過程中(含自動教導功能):按壓+,-鍵不放(右指示燈持續亮)時"0.5"秒後,數值"不"閃爍,且數值馬上做增減動作。
- 調整完畢:放開按鍵 數值閃爍"3"秒後自動寫入當前門檻值之後數值停止閃爍。

Main screen  
主畫面



Mode setting  
功能模式設定方式

Press + & - both button to enter setting function (Mode)  
同時+與-進入模式選擇(Mode)·左右指示燈綠燈"同時"閃爍2秒  
(亮0.25 sec 暗0.25sec 持續4次)



- In mode selection / 於模式選擇中: (1) Press - to change the "mode selection" / 按-鍵切換"模式選擇"  
(2) Press + to change the "setting options" / 按+鍵更改"設定選項"  
(3) After 5 seconds, without pressing any button, it will back to main screen. / 5秒後沒有任何按鍵，即跳回"門檻值"視窗
- In setting selection / 於設定選項中: (1) After 5 seconds, without pressing any button, it will back to main screen. / 5秒後沒有任何按鍵，即跳回"門檻值"視窗  
(2) Press - to confirm the option / 按-鍵即確定選項

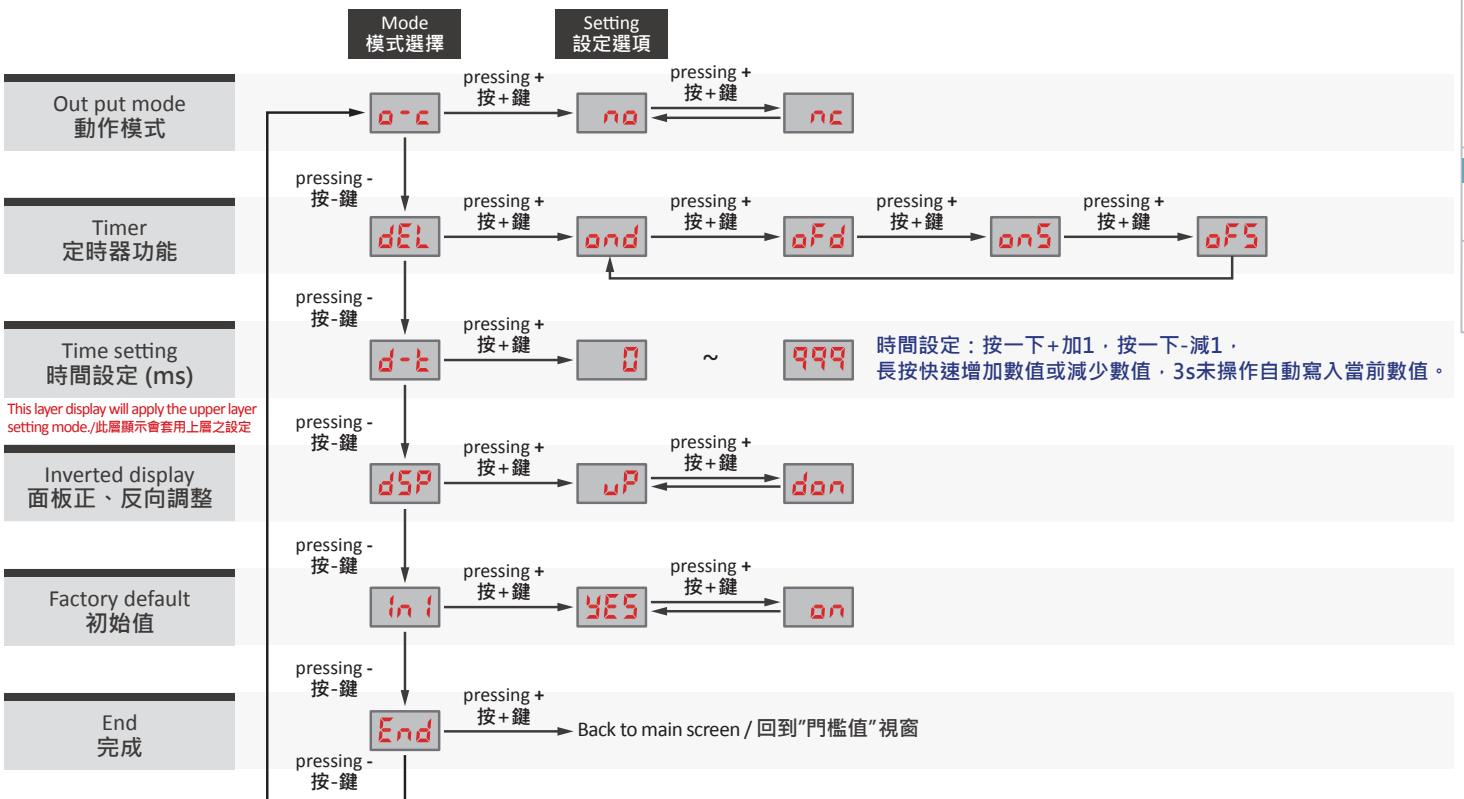

SID

電感式 / 靜電容近接開關

Ø3  
Ø4  
M5  
Ø6  
M8  
M12  
M18  
M30

JM  
JN  
KND  
PN  
PND  
RN  
SN

SID  
SIR  
SIA

KC  
KCT  
KCP

## Characteristic / 特點：

- Suitable for the detection of tiny metal passing.  
/ 適合檢測通過的微小金屬。
- The pigtailed type connector makes easy disconnection.  
/ 有端子式，讓您能夠迅速的更換。
- 12-turn sensitivity adjuster. Users can adjust the sensitivity more optimum according to different objects.  
/ 可調式旋鈕(12轉)，可依據感測物的大小而有所調整。
- Dual LED makes you easy to know the current operating situation.  
/ 後端雙LED顯示，能夠讓您在使用的時候容易判斷輸出的狀況。



SIR

電感式 / 靜電容近接開關

Ø3  
Ø4  
M5  
Ø6  
M8  
M12  
M18  
M30

JM  
JN  
KND  
PN  
PND  
RN  
SN

SID  
SIR  
SIA

KC  
KCT  
KCP

Model / 型號	出線式 Ø4.2	SIR15-KP2	SIR22-KP2	SIR30-KP2
	M12出線式接頭型	SIR15-KP2K1	SIR22-KP2K1	SIR30-KP2K1
Sensing hole diameter / 檢測孔直徑		D=15mm	D=22mm	D=30mm
Min. detecting object / 最小檢測物		2mm min.	3mm min.	3mm min.
Operating voltage / 工作電壓		DC 12 ~ 24V		
Current consumption / 消耗電流		25 mA Max.		
Load current / 負載電流		100 mA Max. at DC 24V		
Output method / 輸出模式		NPN N.O./N.C. PNP N.C./N.O.		
Operating temperature / 工作溫度		-20°C ~ + 60°C		
Protection degree / 防水等級		IP 66		
Option / 選購配件		M124R-PVC-2M		
Wiring method / 出線方式	SIR-□KP2	Ø5.2 x 2M / 4 wires		
	SIR-□KP2K1	M12 plug in connector type / M12 接頭型		
Weight / 重量	SIR-□KP2	86g	85g	81g
	SIR-□KP2K1	30g	29g	25g

※ 不適用於高速計數模式

## Dimensions / 尺寸圖 (mm)

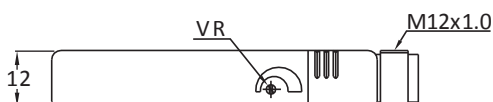
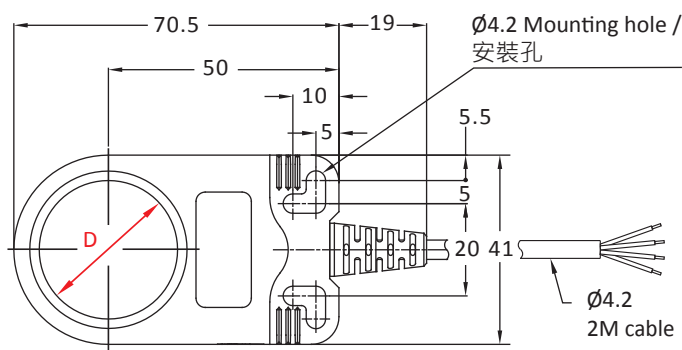

## Wiring diagrams / 接線圖

-KP2

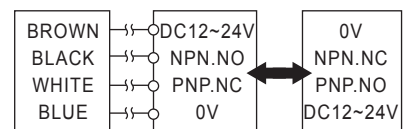

-KP2K1

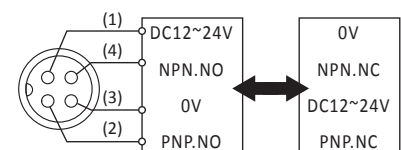

(1) BROWN (3) BLUE  
(2) WHITE (4) BLACK

## 感測器與金屬物質最小距離 (最小檢測物)

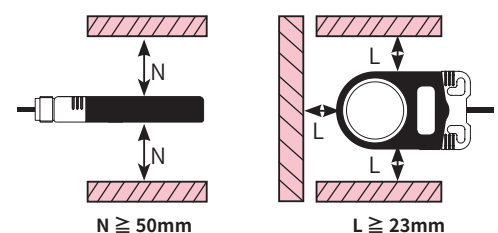

# 環形近接開關

# Ring Inductive Proximity Sensor

## Output method of KP2 series. / KP2的輸出

SIR□-KP2 includes PNP and NPN two output types. Not only available used on PNP type and NPN type, but also NO/NC switching available.

SIR□-KP2含有PNP與NPN兩種輸出狀態，並且能夠NO/NC切換。

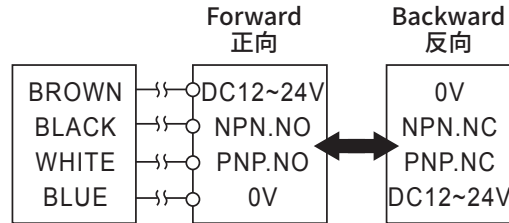

## High brightness dual LED. / 高亮度雙LED燈

The transparent design of rear cover and high brightness dual LED makes you easy to know the current operating situation.

SIR尾蓋為透明狀，並使用高亮度雙LED顯示，能夠讓您在使用的時候容易判斷機體的感應狀況。

Non detecting / 未檢測時...



Detecting / 檢測中...



High brightness dual LED. / 高亮度雙LED指示燈

## Sensitivity adjuster. / 可調式旋鈕

12-turn Sensitivity adjuster. Users can adjust the sensitivity more optimum according to different objects.

可調式旋鈕(12轉)，可依據感測物的大小而有所調整。



VR 12-turn adjuster / 可調式旋鈕(12轉)

## Pre-wired type & Plug-in connector type. / 出線式 & 端子式

Pre-wired type or plug-in connector type available.

有出線式與端子式兩種選擇。

Pre-wired type / 出線式



Plug-in connector / 端子式



SIR

電感式 / 靜電容近接開關

Ø3  
Ø4  
M5  
Ø6  
M8  
M12  
M18  
M30

JM  
JN  
KND  
PN  
PND  
RN  
SN

SID  
SIR  
SIA

KC  
KCT  
KCP

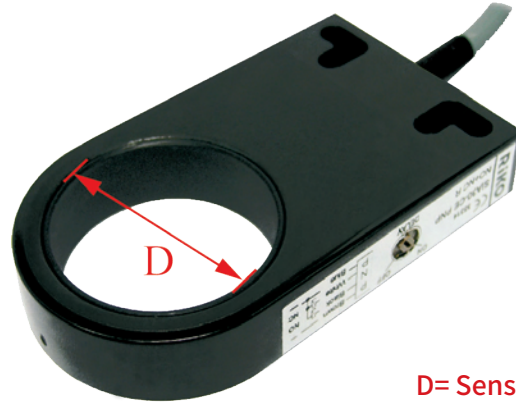

D= Sensing hole diameter (檢測孔直徑)

SIA

電感式 - 靜電容近接開關

Ø3  
Ø4  
M5  
Ø6  
M8  
M12  
M18  
M30

JM  
JN  
KND  
PN  
PND  
RN  
SN

SID  
SIR  
SIA

KC  
KCT  
KCP

Model / 型號	NPN N.O./N.C.	SIA05-N	SIA12-N	SIA15-N	SIA22-N	SIA30-N
	PNP N.O./N.C.	SIA05-P	SIA12-P	SIA15-P	SIA22-P	SIA30-N
Sensing hole diameter / 檢測孔直徑		D=5mm	D=12mm	D=15mm	D=22mm	D=30mm
Min. detecting object / 最小檢測物		0.7mm min.	1.2mm min.	2mm min.	3mm min.	
Operating voltage / 工作電壓	DC 10 ~ 30V					
Current consumption / 消耗電流	15 mA					
Load current / 負載電流	100 mA Max. at DC 24V					
Operating temperature / 工作溫度	-20°C ~ + 60°C					
Protection degree / 防水等級	IP 65					
Wiring method / 出線方式	Ø4.2 x 2 M / 4 wires					
Recommended power unit / 應用電源供給單元	ST - 1 . ST - T2					
Weight / 重量	100g					

## Dimensions / 尺寸圖 (mm)

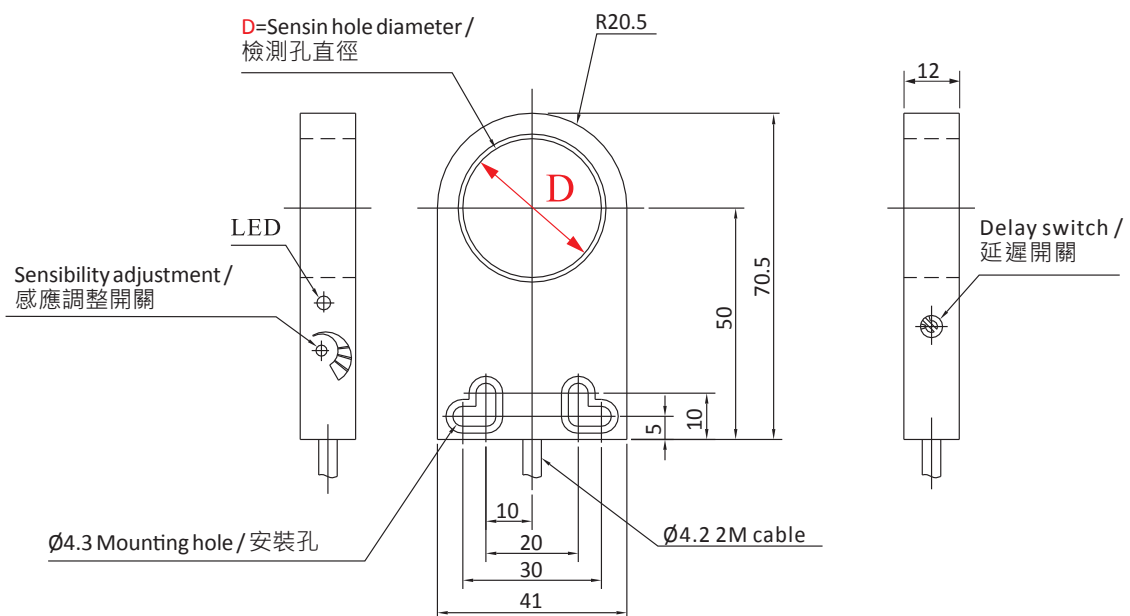

# 環形近接開關

# Ring Inductive Proximity Sensor

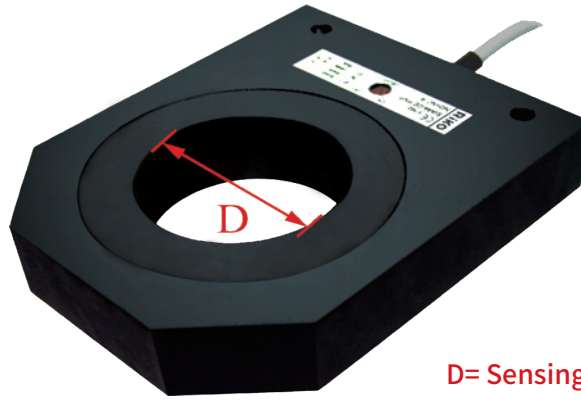

D= Sensing hole diameter (檢測孔直徑)

Model / 型號	NPN N.O./N.C.	SIA44-N	SIA63-N	SIA100-N
	PNP N.O./N.C.	SIA44-P	SIA63-P	SIA100-P
Sensing hole diameter / 檢測孔直徑		D=44mm	D=63mm	D=100mm
Min. detecting object / 最小檢測物		5mm min.		10mm min.
Operating voltage / 工作電壓		DC 10 ~ 30V		
Current consumption / 消耗電流		15 mA		
Load current / 負載電流		100 mA Max. at DC 24V		
Operating temperature / 工作溫度		-20°C ~ +60°C		
Protection degree / 防水等級		IP 65		
Wiring method / 出線方式		Ø4.2 x 2 M / 4 wires		
Recommended power unit / 應用電源供給單元		ST - 1. ST - T2		
Weight / 重量		260g	220g	710g

## Dimensions / 尺寸圖 (mm)

### SIA44-□ / SIA63-□

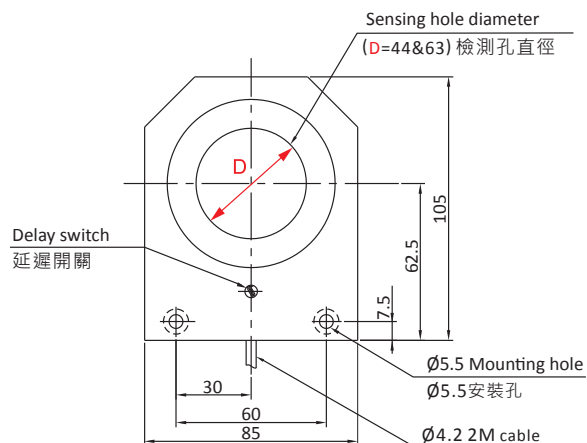

### SIA100-□

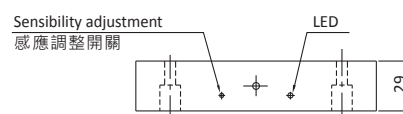
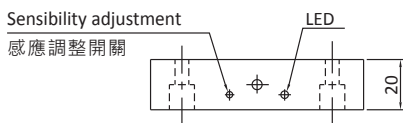
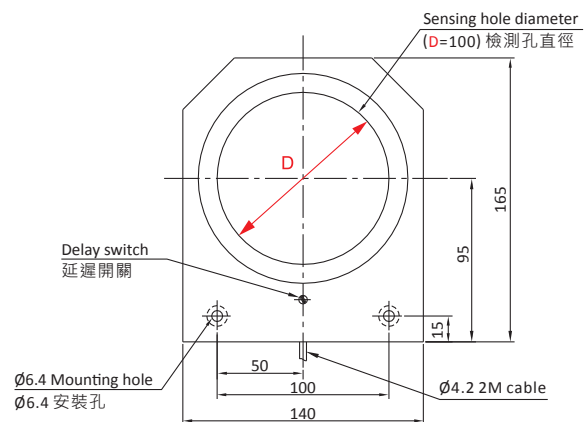

SIA

電感式 / 靜電容近接開關

Ø3  
Ø4  
M5  
Ø6  
M8  
M12  
M18  
M30

JM  
JN  
KND  
PN  
PND  
RN  
SN

SID  
SIR  
SIA

KC  
KCT  
KCP

## Inductive Ring Sensor / 環型近接感應器

SIA series

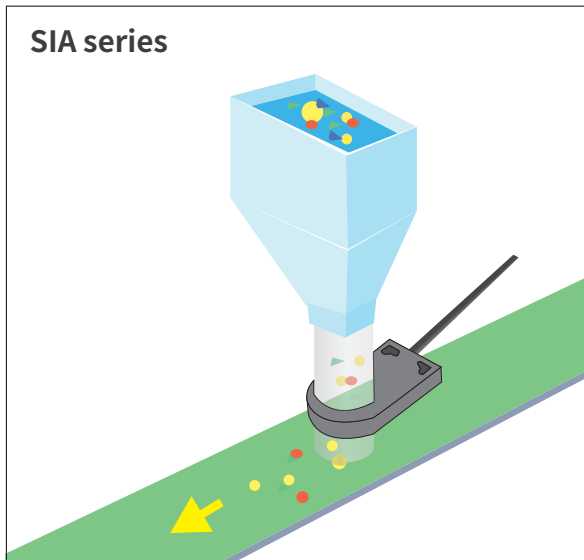

### Effects Of Metal In The Close Vicinity

If a moving metal part is closed to the sensing area the function can be disturbed. In order to avoid this, install the units some distance from metallic object. Ensure that this dose not away interfere the function.

### 金屬接近感應區域的影響

如果有移動的金屬零件靠近感應區域時，感應功能可能會被干擾。為了避免此情況發生，在裝置時，請與金屬物體保持一段距離，以確保不會干擾到感應功能。

### Selection Of Ring Sensor

Selection should be made based on the minimum hole diameter required. In this way the sensitivity adjustment can be made within normal parameters.

### 環型光電感應器的選擇

依據最小洞徑做選擇。如此敏銳性的調整可以在正常值內，而不會有不正當運作的風險。

Model	Length (mm)	Diameter (mm)
SIA05	1	0.7
SIA12	2	1.2
SIA44	9	5
SIA63	12	6
SIA100	20	12

## General Characteristics

In ring sensors, sensing is made within the ring itself. The sensors is activated when a metallic object is introduced within it. They are particularly suitable for applications where detection of small metal objects such as screws, nuts, washers etc...is requested and also for break detection of continuous metal wires that pass through it.

### 一般的特性

環型近接感應器的感應裝置就在其環形物中。當有金屬的物體通過此環形物時，感應器便產生作用。

特別適合用於檢測細小的金屬物體，例如螺絲釘、螺帽、墊圈等。以及連續金屬線的斷裂檢測。感應器的外罩是塑膠製。內徑為5、12、15、22、30、44、63、100 mm。

### Use With A Delayed Amplifiers

All types of ring sensors can work in combination with a delayed amplifier of the programmable ALTP series which ensures the sensing of small object in rapid movement.

### 與延遲輸出共同使用

所有形式的環型近接感應器，皆能用於可編程序的ALTP系列的延遲放大器，並可確保檢測快速移動的小物體。

### Use With A Delayed Amplifiers

A distance equal to the width of the sensor should be left between each objects that passes through the sensor. If more than one sensor is to be installed in close vicinity, the minimum distance indicated between sensors should be observed.

### 感應器的使用

通過感應器的每件物體，至少要有一個感應器寬度的間隔距離。如果超過一個以上的感應器，被裝置在鄰近區域，其相互間距離，必須遵守如附表所示的最小距離。

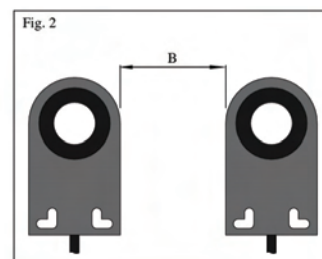
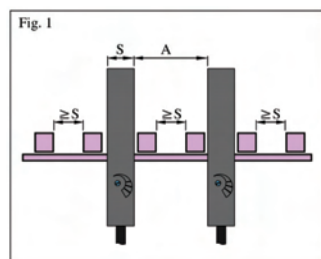

感應器間的最小距離

Model	SIA05	SIA12	SIA44	SIA63	SIA100
A(Fig.1) mm	25	30	300	300	600
B(Fig.2) mm	10	10	250	250	650

SIA

電感式 - 靜電容近接開關

Ø3  
Ø4  
Ø5  
Ø6  
Ø8  
Ø12  
Ø18  
Ø30

JM  
JN  
KND  
PN  
PND  
RN  
SN

SID  
SIR  
SIA

KC  
KCT  
KCP

## Sensitivity Adjustment

After having followed the instructions regarding the choice of the most suitable unit it is recommended that the sensitivity adjustment be carried out when the sensor is installed in the final position taking into account how much metal mass is close by which could alter its functioning. The sensitivity increases turning the trimmer clockwise.

### 靈敏度的調整

根據操作指南的指示，挑選最適合的型號後，強烈建議在最後安裝定位後，再做敏銳度的調整，並注意是否有任何的金屬物體會影響到它的正常功能。順時針方向旋轉可增加敏銳度。

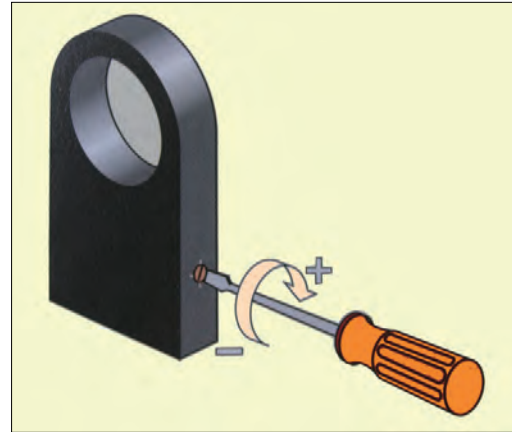

## Switching Frequency

The switch frequency of inductive ring sensors depends on delayed impulse time (when inserted) according to the formula:

$$\text{Switching frequency (Hz)} = \frac{1}{(T \text{ impulse} + 10) \text{ ms}}$$

Vice versa, switching frequency will be as per chart beside.

### 動作頻率

環型近接感應器的切換頻率取決於被測物通過時延遲的脈衝時間，並依據以下公式：

$$\text{切換頻率 (Hz)} = \frac{1}{(T \text{ 延遲輸出時間} + 10) \text{ ms}}$$

## Delay On De-energization

All our inductive ring sensors, NPN and PNP amplified versions, are supplied with an ON-OFF switch to activate and deactivate delay on de-energization 100ms. This delay allows the sensor to detect small metallic objects passing rapidly through the sensitivity area of the ring.

### 延遲輸出

所有我們的環型近接感應器(NPN和PNP放大型式)都備有ON-OFF開關，以控制輸出供給的延遲100ms。這個延遲提供感應器能夠檢測出金屬小物體快速的通過感應區域。

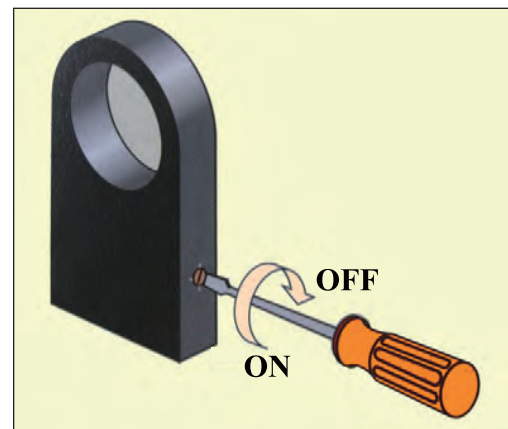

Model	開關動作頻率
SIA05	600~1500
SIA12	600~1000
SIA15	600~1000
SIA22	600~1000
SIA30	600~800
SIA44	250~600
SIA63	100~200
SIA100	≤100

SIA

電感式 - 靜電容近接開關

Ø3  
Ø4  
M5  
Ø6  
M8  
M12  
M18  
M30

JM  
JN  
KND  
PN  
PND  
RN  
SN

SID  
SIR  
SIA

KC  
KCT  
KCP

## Characteristic / 特點：

- Maximum distance to grounded metal target.  
/ 對有接地金屬，可獲得最大檢測距離。
- Sensitivity adjustment: 20-turn potentiometer (VR).  
/ 多轉式VR(20轉)，方便調整。
- Widely applied to detect metal, oil, glass, plastic, paper etc.  
/ 靜電容近接可廣泛應用於檢測金屬、水、油、玻璃、塑膠、紙等。



KC

電感式—靜電容近接開關

Ø3  
Ø4  
M5  
Ø6  
M8  
M12  
M18  
M30

JM  
JN  
KND  
PN  
PND  
RN  
SN

SID  
SIR  
SIA

KC  
KCT  
KCP

Model / 型號	NPN N.O./N.C. PNP N.C./N.O.	KC1820-KP2	KC1820-KP2K
Sensing distance / 檢出距離		1 ~ 16 mm	
Standard sensing object / 標準檢測物		Conducting Neutral / 導體電中性	
Description / 外型		Standard M18 / 標準M18	
Hysteresis / 遲滯		≤ 10 % of sensing distance	
Response time / 反應頻率		70 Hz	
Operating voltage / 工作電壓		DC 12 ~ 24V	
Current consumption / 消耗電流		≤ 22 mA no-load	
Load current / 負載電流		100 mA Max. at DC 24V	
Residual voltage / 殘餘電壓		≤ DC 1.5V	
Insulation resistance / 隔離阻抗		20M Ω min. (DC500V)	
Voltage withstandability / 絕緣耐壓		AC1000V 60Hz for 60 Sec.	
Operating temperature / 工作溫度		-20°C ~ + 60°C	
Protection degree / 防水等級		IP 66	
Wiring method / 出線方式		Per-wired Ø4.2 x 2M / 4 wires	M12 pigtailed type / M12 出線式接頭型
Option / 選購配件		Bracket / 固定架：MF-01 M124R-PVC-2M	
Weight / 重量		70g	35g
<b>Wiring diagrams / 接線圖</b>			
<b>-KP2</b>			
<b>-KP2K</b>			

# 靜電容式近接開關

# Capacitive Proximity Sensor

## Characteristic / 特點：

- Maximum distance to grounded metal target.  
/ 對有接地金屬，可獲得最大檢測距離。
- Sensitivity adjustment: 20-turn potentiometer (VR).  
/ 多轉式VR(20轉)，方便調整。
- Widely applied to detect metal, oil, glass, plastic, paper etc.  
/ 靜電容近接可廣泛應用於檢測金屬、水、油、玻璃、塑膠、紙等。



Model / 型號	NPN N.O./N.C. PNP N.C./N.O.	KC3035-KP2	KC3035-KP2K
Sensing distance / 檢出距離		2 ~ 30mm	
Standard sensing object / 標準檢測物		Conducting Neutral / 導體電中性	
Description / 外型		Standard M30 / 標準M30	
Hysteresis / 遲滯		≤ 10 % of sensing distance	
Response time / 反應頻率		50 Hz	
Operating voltage / 工作電壓		DC 12 ~ 24V	
Current consumption / 消耗電流		≤ 22 mA no-load	
Load current / 負載電流		100 mA Max. at DC 24V	
Residual voltage / 殘餘電壓		≤ DC 1.5V	
Insulation resistance / 隔離阻抗		20M Ω min. (DC500V)	
Voltage withstandability / 絕緣耐壓		AC1000V 60Hz for 60 Sec.	
Operating temperature / 工作溫度		- 20°C ~ + 60°C	
Protection degree / 防水等級		IP 66	
Option / 選購配件		MF-01 Bracket / 固定架 M124R-PVC-2M	
Wiring method / 出線方式		Per-wired Ø5.2 x 2M / 4 wires	M12 pigtailed type / M12 出線式接頭型
Weight / 重量		135g	80g
<b>Wiring diagrams / 接線圖</b>			
<b>-KP2</b>			
<b>-KP2K</b>			

KC

電感式  
靜電容  
近接開關

Ø3  
Ø4  
M5  
Ø6  
M8  
M12  
M18  
M30

JM  
JN  
KND  
PN  
PND  
RN  
SN

SID  
SIR  
SIA

KC  
KCT  
KCP

## Wiring diagrams / 接線圖

KC□-KP2 includes PNP and NPN two output types.  
Not only available used on PNP type and NPN type, but also NO/NC switching available.

KC□-KP2 包含 PNP 和 NPN 兩種輸出模式。  
不是只有PNP和NPN兩種輸出模式同時存在，也包含了NO/NC兩種開關模式。

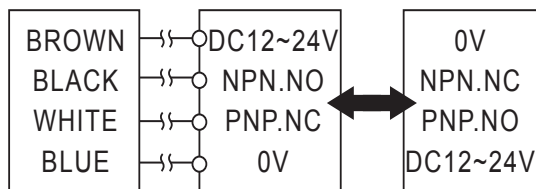

## Function introduction / 功能介紹

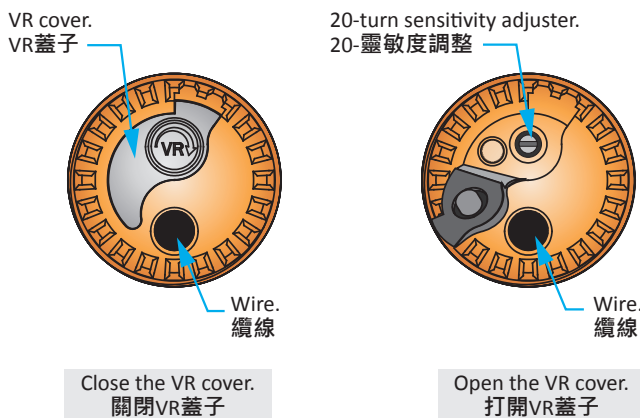

KC□-KP2 with 20-turn sensitivity adjuster. Users can adjust the sensitivity according to different objects. Special VR cover for water-proof and greasiness-proof.

KC□-KP2 為可調式旋鈕(20轉)，可依據感測物的不同，而有所調整。另外，在旋鈕上附有VR蓋，不但能夠防水還能防油污。

## Precautions proper installation / 安裝注意事項

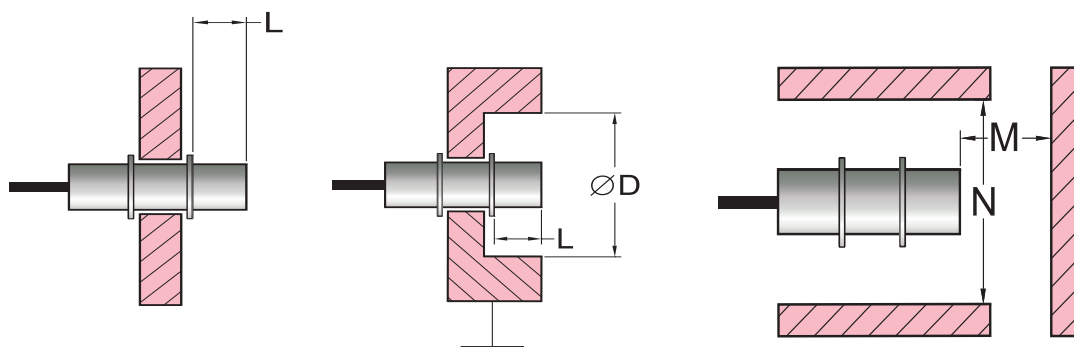

**KC1820**  $D \geq 40\text{mm}$   $M \geq 30\text{mm}$   $L \geq 30\text{mm}$   $N \geq 40\text{mm}$

**KC3035**  $D \geq 90\text{mm}$   $M \geq 50\text{mm}$   $L \geq 30\text{mm}$   $N \geq 90\text{mm}$

# 圓管形靜電容式近接開關

# Tubular Capacitive Proximity Sensor

## Characteristic / 特點：

- Maximum distance to grounded metal target.  
/ 對有接地金屬，可獲得最大檢測距離。
- Sensitivity adjustment：20-turn potentiometer (VR).  
/ 多轉式VR(20轉)，方便調整。
- Widely applied to detect metal, water, oil, glass, plastics, paper etc.  
/ 靜電容近接可廣泛應用於檢測金屬、水、油、玻璃、塑膠、紙等。



Model / 型號	NPN N.O./N.C. PNP N.O./N.C.	KCT1810-KP2	KCT1810-KP2K
Sensing distance / 檢出距離		1~10 mm	
Standard sensing object / 標準檢測物		Conducting Neutral / 導體電中性	
Description / 外型		Standard M18 / 標準M18	
Hysteresis / 遲滯		≤ 10 % of sensing distance	
Response time / 反應頻率		70 Hz	
Operating voltage / 工作電壓		DC 12 ~ 24V	
Current consumption / 消耗電流		≤ 22 mA no-load	
Load current / 負載電流		100 mA Max. at DC 24V	
Residual voltage / 殘餘電壓		≤ DC 1.5V	
Insulation resistance / 隔離阻抗		20M Ω min. (DC500V)	
Voltage withstandability / 絕緣耐壓		AC1000V 60Hz for 60 Sec.	
Operating temperature / 工作溫度		-20°C ~ +60°C	
Protection degree / 防水等級		IP66	
Option / 選購配件		M124R-PVC-2M	
Wiring method / 出線方式		Ø4.2 x 2M / 4 wires	M12 pigtailed type / M12 接頭型
Weight / 重量		78g	40g
<b>Wiring diagrams / 接線圖</b>			
<b>-KP2</b>			
<b>-KP2K</b>			

KCT

電感式 / 靜電容式近接開關

Ø3  
Ø4  
M5  
Ø6  
M8  
M12  
M18  
M30

JM  
JN  
KND  
PN  
PND  
RN  
SN

SID  
SIR  
SIA

KC  
KCT  
KCP

## Characteristic / 特點：

- Slim housing only 7mm.  
/ 薄型厚度僅 7 mm。
- Sensitivity adjustment : multi-turn potentiometer.  
/ 多轉式VR方便調整。
- IP67 protection degree.  
/ IP67 防護等級。
- Widely applied to detect metal, water, oil, glass, plastic, solar panel.  
/ 可廣泛應用於 金屬, 水, 油, 玻璃, 塑膠, 太陽能板。



Model / 型號	KCP10-N	KCP10-N2
Operating distance / 檢測距離	10 mm	
Current consumption / 消耗電流	<9 mA	
Load current / 負載電流	200 mA	
Operating voltage / 工作電壓	10~ 30 VDC	
Output / 輸出模式	NPN.NO	NPN.NC
Voltage drop / 壓降	<2 V @ 200 mA	
Switching frequency / 反應頻率	100 Hz	
Operating temperature / 工作溫度	-25°C ~ 75°C	
Protection degree / 防護等級	IP67	
Casing material / 外殼材料	PBT	
Connection / 連接方式	PVC, ultra-flex	

KCP

電感式 / 靜電容式近接開關

Ø3  
Ø4  
M5  
Ø6  
M8  
M12  
M18  
M30

JM  
JN  
KND  
PN  
PND  
RN  
SN

SID  
SIR  
SIA

KC  
KCT  
KCP

## Dimensions / 尺寸圖 (mm)

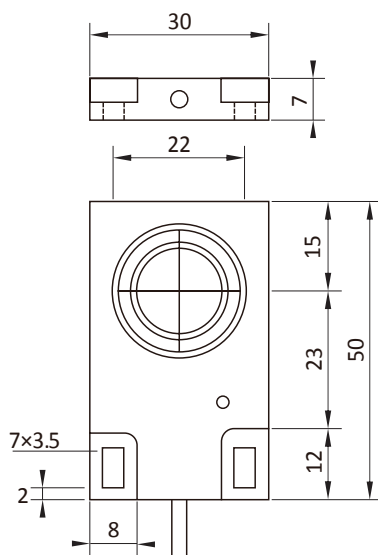

## Wiring diagrams / 接線圖

-N

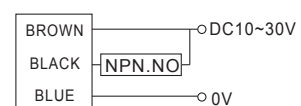

-N2

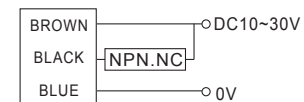

# 方形靜電容式近接開關

## Rectangular Capacitive Proximity Sensor

### Characteristic / 特點：

- Detecting non-metal targets: water, oil, glass, plastic.  
/ 可檢測：水、油、玻璃、塑膠等非金屬物。
- Setted sensing distance for installation.  
/ 固定檢測距離，適合特別安裝。



Model / 型號	NPN N.O. / N.C.	KCP16-N3	KCP16-N3K1
	PNP N.O. / N.C.	KCP16-P3	KCP16-P3K1
Sensing distance / 檢出距離	16 mm		
Standard sensing object / 標準檢測物	導體電中性		
Description / 外型	上方		
Hysteresis / 遲滯	檢測距離的 10 % 以下		
Response time / 反應頻率	100 Hz		
Operating voltage / 工作電壓	DC 12 ~ 24V		
Current consumption / 消耗電流	無負載 22 mA 以下		
Load current / 負載電流	最大 100 mA at DC 24V		
Residual voltage / 殘餘電壓	≤ DC 1.5V		
Insulation resistance / 隔離阻抗	最小 20M Ω (DC500V)		
Voltage withstandability / 絕緣耐壓	AC1000V 60Hz 持續 60 Sec.		
Operating temperature / 工作溫度	-20°C ~ +60°C		
Protection degree / 防水等級	IP66		
Option / 選購配件	M124R-PVC-2M		
Wiring method / 出線方式	Ø5.2 x 2M / 4 線	M12 接頭型	
Weight / 重量	106g	36g	

### Dimensions / 尺寸圖 (mm)

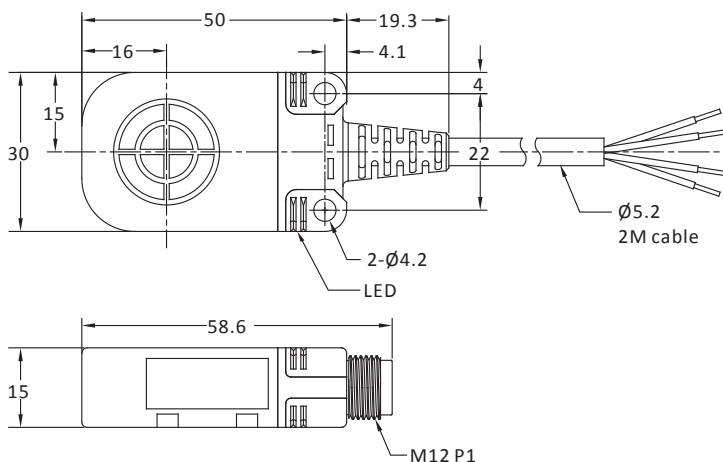

### Wiring diagrams / 接線圖

#### -N3

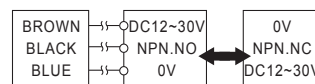

#### -P3K1

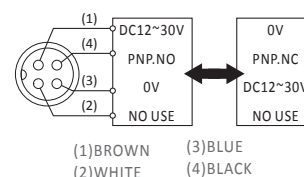

KCP

電感式 / 靜電容式近接開關

Ø3  
Ø4  
M5  
Ø6  
M8  
M12  
M18  
M30

JM  
JN  
KND  
PN  
PND  
RN  
SN

SID  
SIR  
SIA

KC  
KCT  
KCP

# Others

## 其他

Controller 控制器	ST-1 ST-T2	151 151
Rechargeable Multi-function Sensor Tester 可充電式多功能測試器	ST-7	153
Accessories 配件	固定架 鏡片 接頭線 多功能固定架	154 156 157 159

## Characteristic / 特點：

- 12VDC / 50mA external power supply.  
/ 提供電源輸出DC12V / 50mA。
- Available in NPN or PNP, ON / OFF-delay, One-shot, functions.  
/ 可接受NPN 或 PNP輸入方式。
- ON / OFF-Delay (0~10sec).  
/ ON / OFF延遲 (0~10sec)。
- Easy for operating.  
/ 操作容易簡便。



Model / 型號	ST-1	ST-T2
Adop controller / 控制選擇	Power Source with Relay Out / "電源供給" 及 "繼電器輸出"	Power Source with Timer Function / "電源供給" 及 "計時功能"
Input voltage / 輸入電壓	AC 110 V or AC 220V 50 / 60 Hz (±10%)	
Current consumption / 消耗電流	≤ 8mA NO-Load	
DC Output voltage / 直流輸出電壓	DC 12V ± 10%	
Load current / 負載電流	50 mA Max	
Delay timer functions / 延遲動作時間	-	ON / OFF - Delay Out (0 ~ 10 sec) One - Shot Out (0 ~ 10 sec)
Relay output / 輸出接點容量	AC 250V 3A	
Operation temperature / 工作時溫度	- 25°C ~ + 60°C	
Weight / 重量	135g	240g
Remark / 備註	This product is used with 8PFAW, but the pedestal is extra purchase. /此項產品須配座8PFAW使用,但座需另外購買	

ST

其他

ST-1

ST-T2

ST-7

ACC.

## Order Information / 訂貨索引

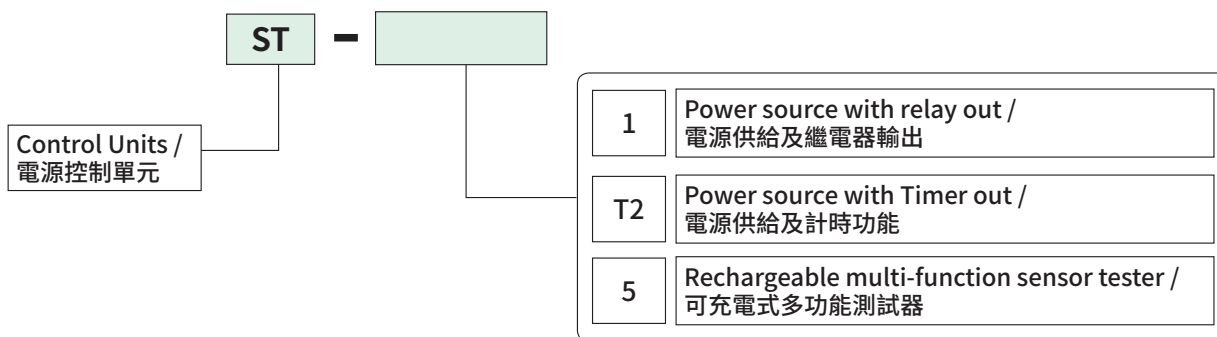

## Dimensions / 尺寸圖 (mm)

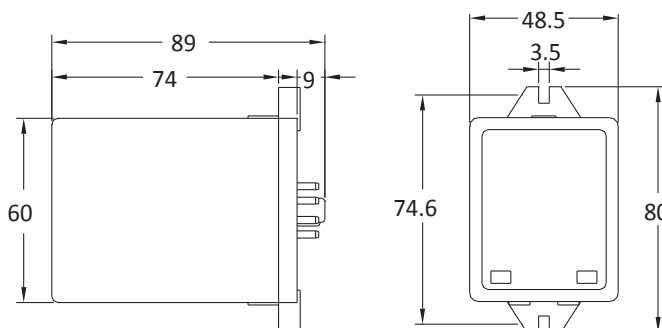

## ST-T2 Timing Chart / ST-T2 時序圖

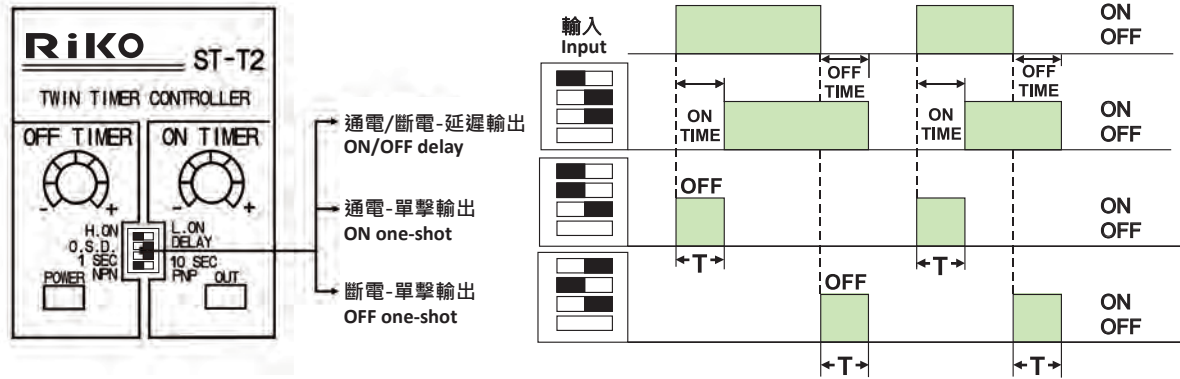

- The timer functions are selected by 4-DIP switches / 功能設定由面板指撥開關變更
- "T" is the TIME of the Off Timer Range. / T: 延遲時間範圍
- The knob of ON TIMER must be at 0 sec. position during ON one-shot and OFF one-shot operations. / 如果使用O.S.D.(通電/斷電單擊輸出)之功能，請將ON TIMER旋鈕調至0 sec，指撥開關切換至O.S.D.

## Connection / 接腳圖

Sensor Combination / 組合應用		
系列 Series	Photoelectric Sensor	Proximity Sensor
	MF	PSC
	RMF	TSC
	SU	SN
	PTQ18	TSN
	PK3	JND
	PK5	SIA
	PM6	SIR

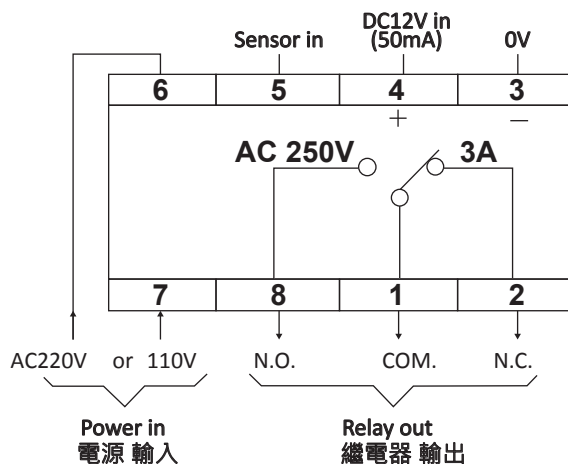

ST

其他

ST-1  
ST-T2

ST-7

ACC.

# 可充電式多功能測試器

## Rechargeable Multifunction Sensor Tester

### Characteristic / 特點：

- Static capacitance button (operation interface). / 靜電容式按鍵(操作介面)。
- Power supply: 24VDC output, load current (100mA max) for the sensor. / 電源提供: 24VDC輸出,負載電流(100mA max)給感測器使用。
- Two groups of NPN / PNP input test. / 兩組NPN/PNP 輸入測試。
- battery reverse protection. / 電池反裝保護。
- External power supply USB connector (Type C) for power supply. / 外部電源USB接頭(Type C)進行供電。
- Set the memory function. / 設定記憶功能。
- Sleep mode, it will automatically turn off after 5 minuts. / 休眠模式(省電模式),5分鐘未動作,將會自動關閉。
- buzzer sound indication. / 蜂鳴器聲音指示。
- The battery is low. The reminder function, the indicator light will flash. / 電池電量不足: 提醒功能,指示燈會閃爍。
- Lighting and fiber optic line sources. / 照明燈和光纖線燈源。

### Panel description / 功能位置：(unit:mm)



### Dimensions / 尺寸圖 (mm)

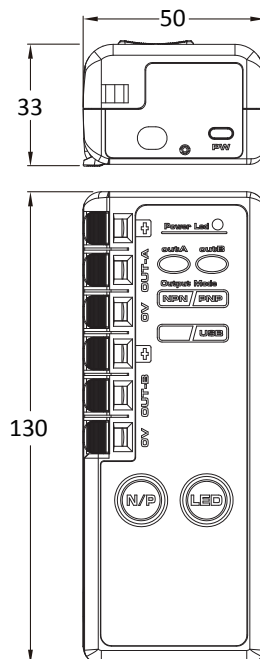

ST-7

其他

ST-1

ST-T2

ST-7

ACC.

• PN05-M001 Mounting Bracket  
PN05-M001 (180度) 固定架

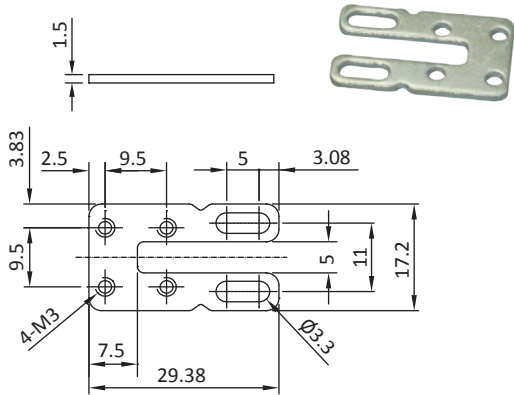

• PN05-M002 Mounting Bracket  
PN05-M002 (90度) 固定架

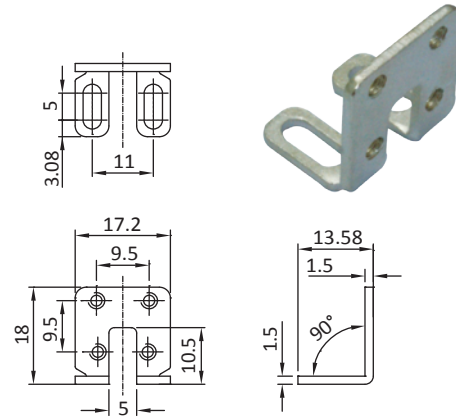

• PN10-M001 Mounting Bracket  
PN10-M001 (180度) 固定架

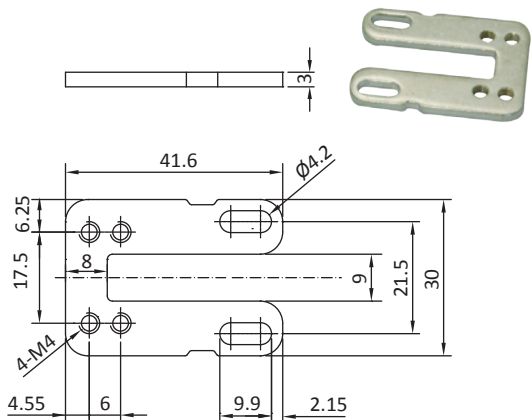

• PN10-M002 Mounting Bracket  
PN10-M002 (90度) 固定架

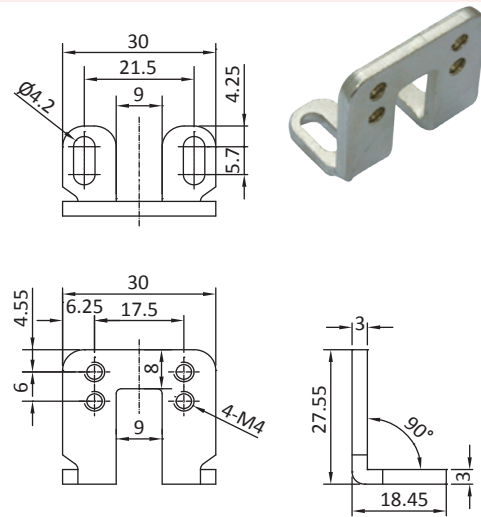

• PN20-M001 Mounting Bracket  
PN20-M001 (180度) 固定架

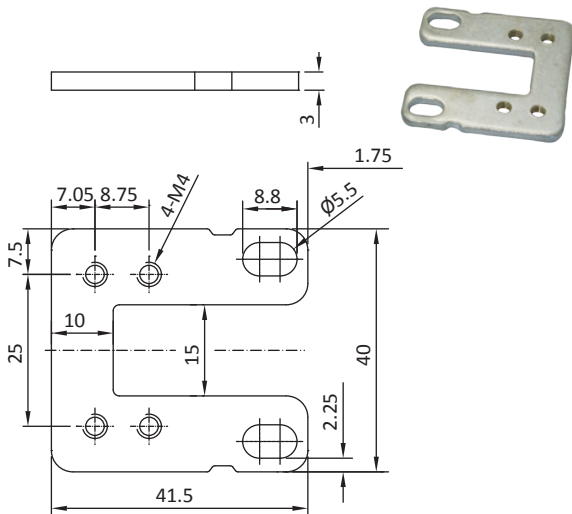

• PN20-M002 Mounting Bracket  
PN20-M002 (90度) 固定架

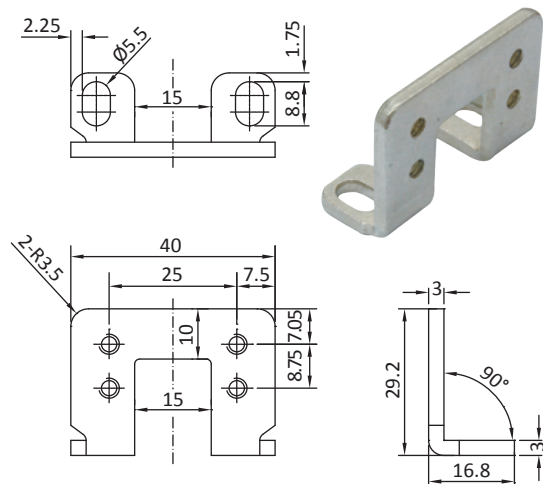

• MF- 01 Mounting Bracket  
MF-01 固定架

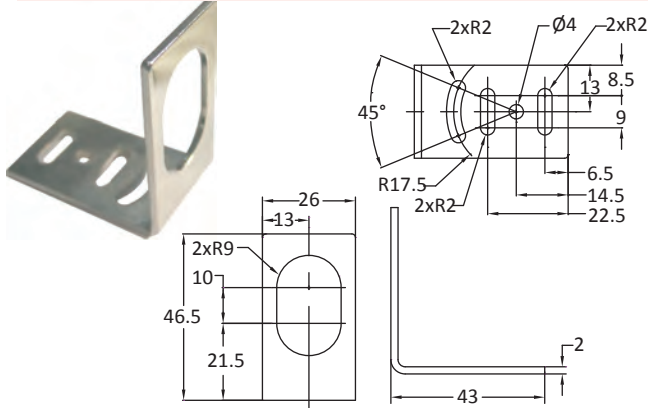

• R3JK-M001 Mounting Bracket  
R3JK-M001 固定架

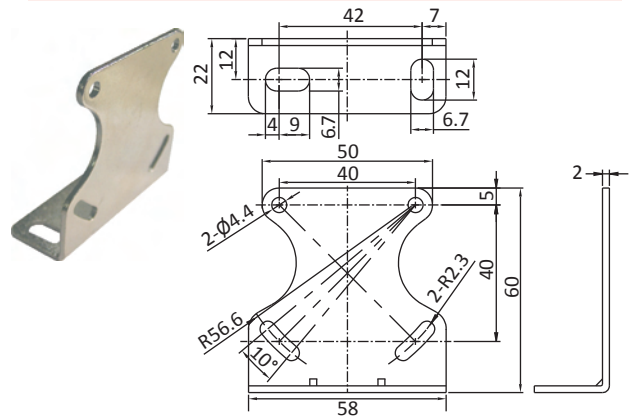

• PK-M001 Mounting Bracket  
PK-M001 固定架

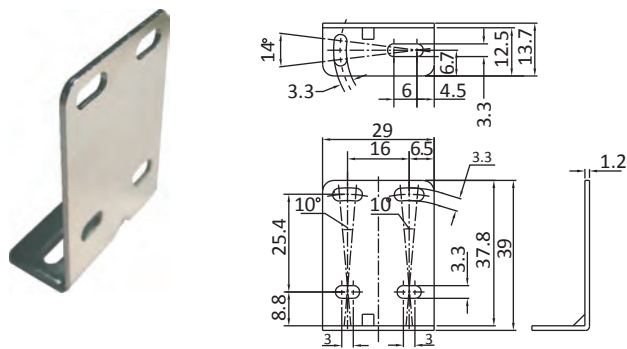

• PK5/PM6 Mounting Bracket  
PK5/PM6 固定架

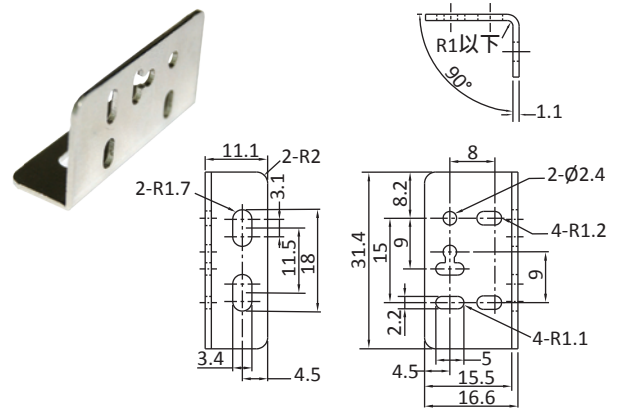

• OAP-M008 Mounting Bracket / OAP-M008 固定架

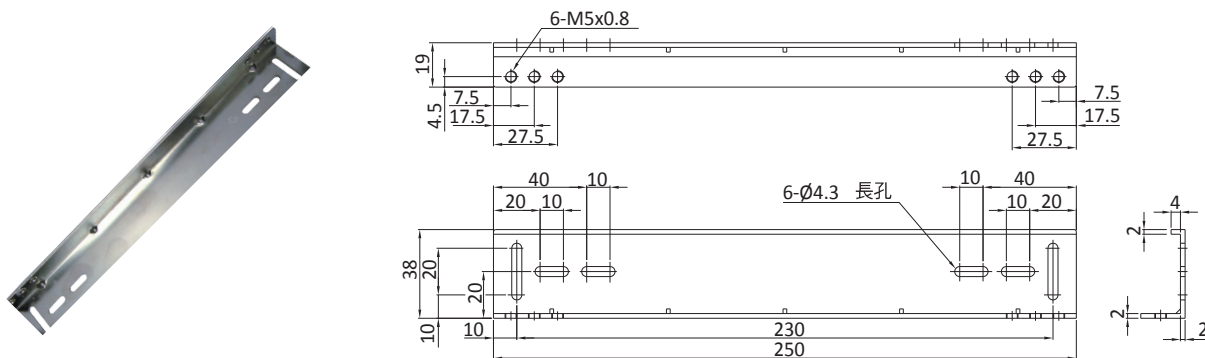

• OAP-M016 Mounting Bracket / OAP-M016 固定架

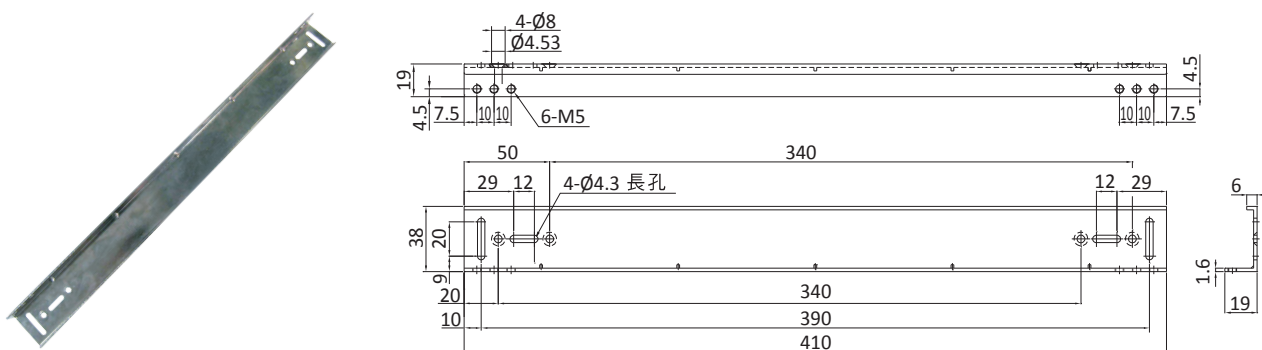

- RR- 03 Reflectors  
RR- 03 鏡片 (厚度 8 mm)

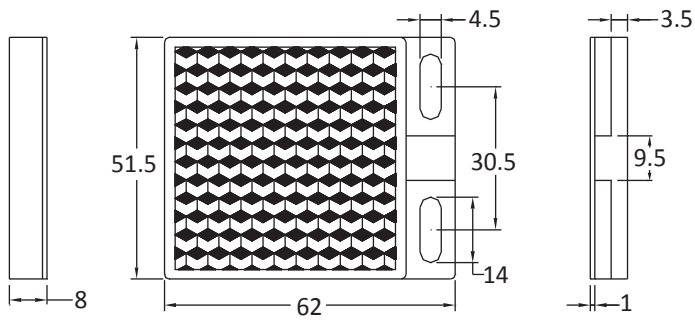

- RR- 03-01 Reflectors  
RR- 03-01 (厚度 8.5 mm)

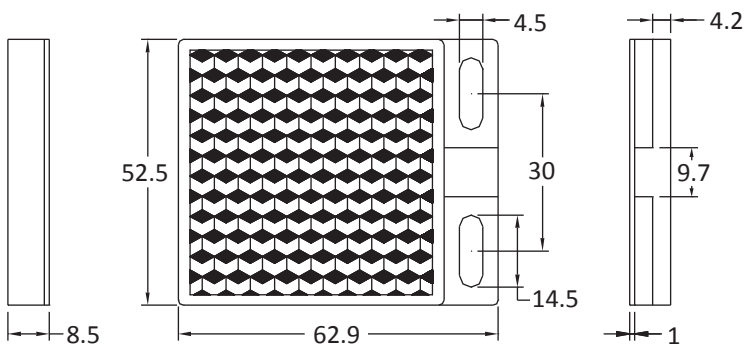

Offers a wide range of connectors that comply with the reliability and application requirement in the field of industrial automation. /

提供多樣化接頭線的選擇，可符合工業自動化領域對可靠性的基本要求，適用大部份客戶的應用場合。

## • M84R-PUR-2M

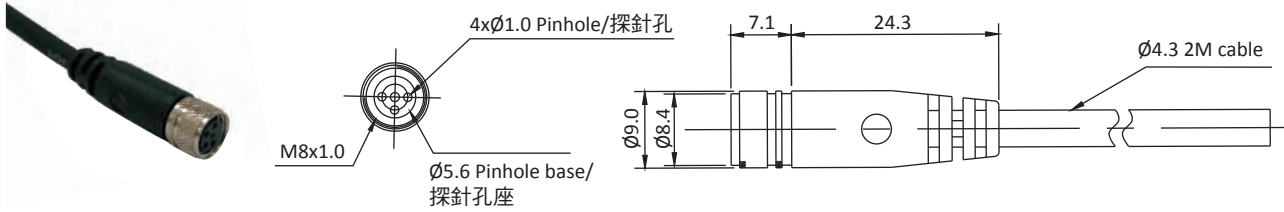

## • R84P-015 (4.2)

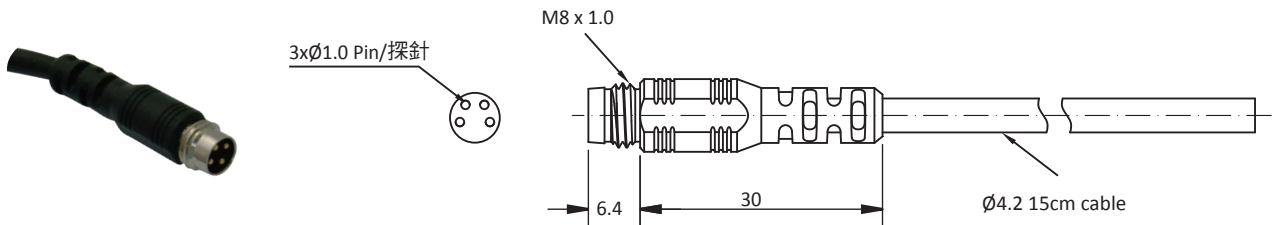

## • M124R-PVC-2M

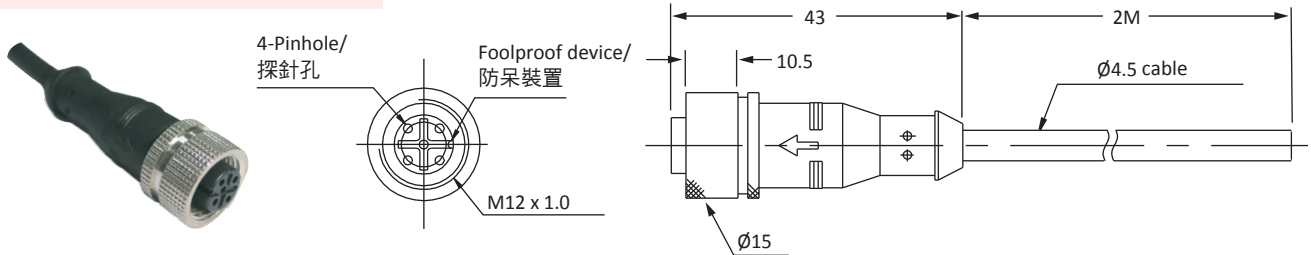

## • M124RL-PVC-2M

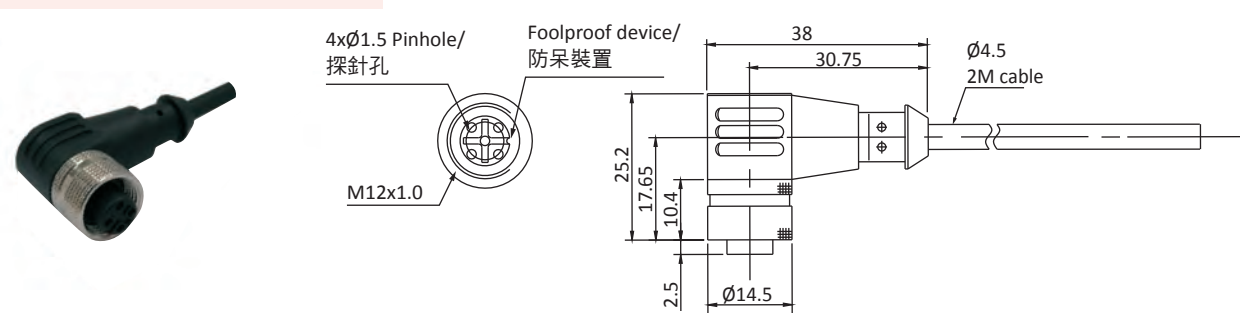

## • M125R-PUR-2M / M125R-PUR-5M

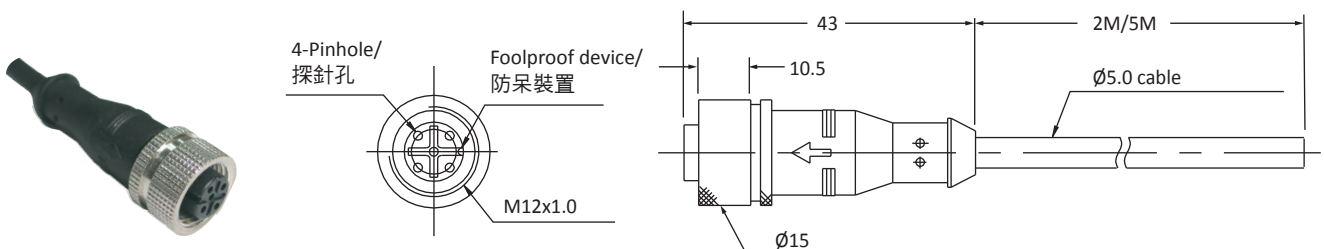

## • R124P-20

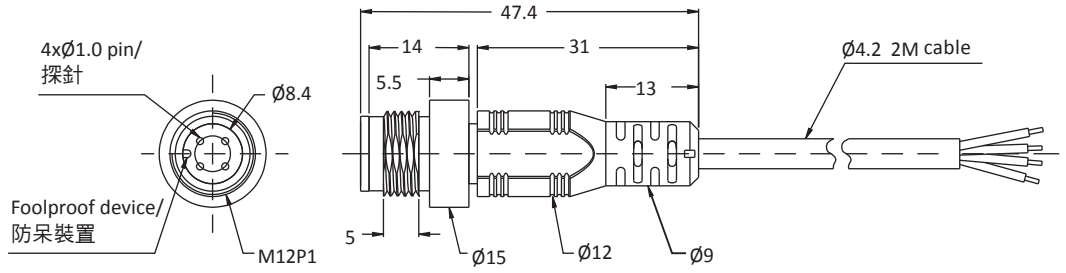

## • R125P-20

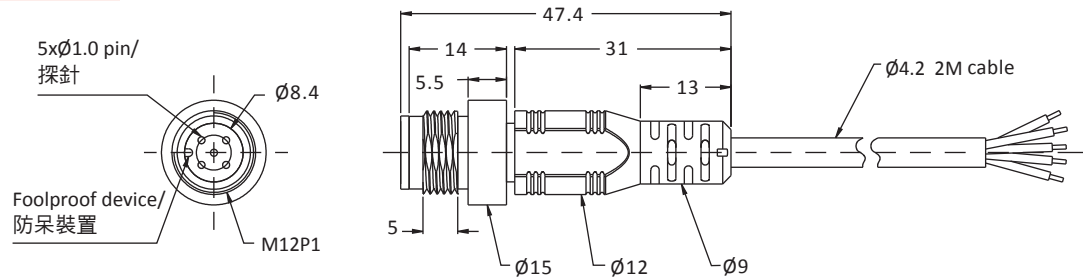

## • RM125-T3

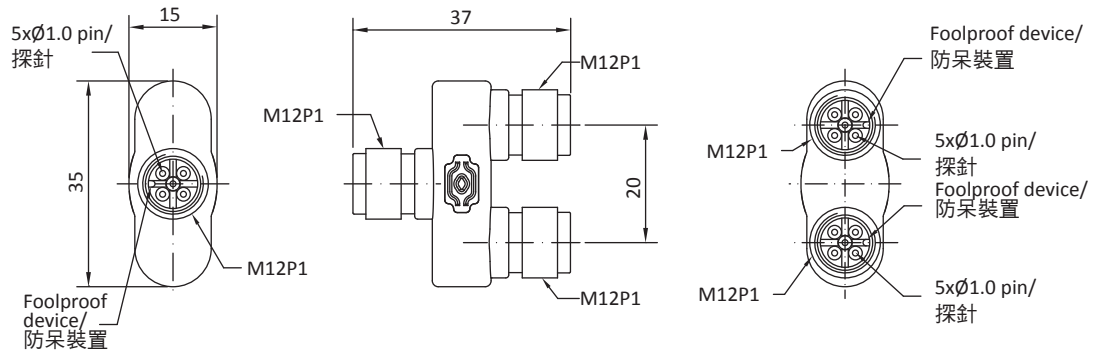

## • EE-1001

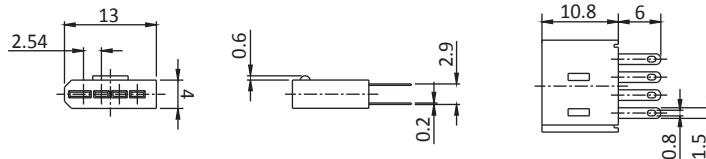

## • RE-1103-PVC-2M

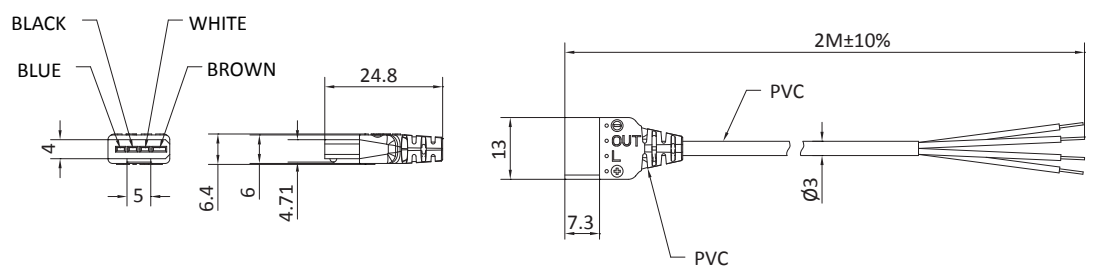

# 多功能固定支架

# Multifunctional Bracket



Model / 型號	
RP015-A001	轉接器
RP015-A002	雙轉接器
RP015-A003	T型座
RP015-A004	螺牙條M4x100mm
RP015-A005	螺牙條M4x150mm

勝特力電材超市-龍山店 886-3-5773766  
 勝特力電材超市-光復店 886-3-5729570  
 勝特力電子(上海) 86-21-34970699  
 勝特力電子(深圳) 86-755-83298787  
<http://www.100y.com.tw>

• RP015-A001

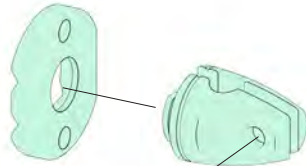

• RP015-A004  
L:100mm



• RP015-A002

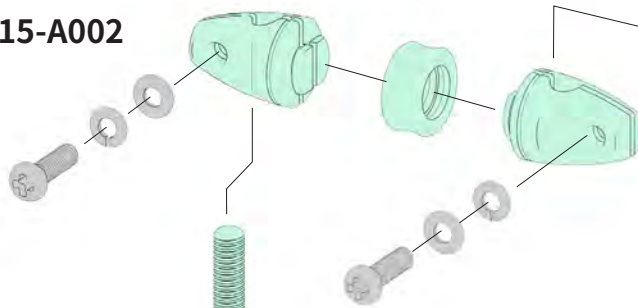

• RP015-A005  
L:150mm



• RP015-A003

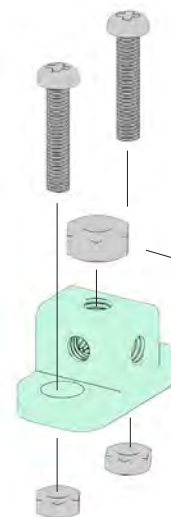

PR015

其他

ST-1  
ST-T2

ST-7

ACC.