



SE97B

DDR memory module temp sensor with integrated SPD

Rev. 01 — 27 January 2010

Product data sheet

1. General description

Meets JEDEC Specification 42.4 TSE2002B1, 3 Jun 2009. The NXP Semiconductors SE97B measures temperature from $-40\text{ }^{\circ}\text{C}$ to $+125\text{ }^{\circ}\text{C}$ with JEDEC Grade B $\pm 1\text{ }^{\circ}\text{C}$ maximum accuracy between $+75\text{ }^{\circ}\text{C}$ and $+95\text{ }^{\circ}\text{C}$ critical zone and also provide 256 bytes of EEPROM memory communicating via the I²C-bus/SMBus. It is typically mounted on a DDR3 Dual In-Line Memory Module (DIMM) measuring the DRAM temperature in accordance with the new JEDEC (JC-42.4) *Mobile Platform Memory Module Temperature Sensor Component* specification and also replacing the Serial Presence Detect (SPD) which is used to store memory module and vendor information.

The SE97B thermal sensor and EEPROM operates over the V_{DD} range of 3.0 V to 3.6 V.

The TS consists of a $\Delta\Sigma$ Analog to Digital Converter (ADC) that monitors and updates its own temperature readings 10 times per second, converts the reading to a digital data, and latches them into the data temperature register. User-programmable registers, the specification of upper/lower alarm and critical temperature trip points, EVENT output control, and temperature shutdown, provide flexibility for DIMM temperature-sensing applications.

When the temperature changes beyond the specified boundary limits, the SE97B outputs an EVENT signal using an open-drain output that can be pulled up between 0.9 V and 3.6 V. The user has the option of setting the EVENT output signal polarity as either an active LOW or active HIGH comparator output for thermostat operation, or as a temperature event interrupt output for microprocessor-based systems. The EVENT output can also be configured as only a critical temperature output.

The EEPROM is designed specifically for DRAM DIMMs SPD. The lower 128 bytes (address 00h to 7Fh) can be Permanent Write Protected (PWP) or Reversible Write Protected (RWP) by software. This allows DRAM vendor and product information to be stored and write protected. The upper 128 bytes (address 80h to FFh) are not write protected and can be used for general purpose data storage.

The SE97B has a single die for both the temp sensor and EEPROM for higher reliability and supports the industry-standard 2-wire I²C-bus/SMBus serial interface. The SMBus TIMEOUT function is supported to prevent system lock-ups. Manufacturer and Device ID registers provide the ability to confirm the identity of the device. Three address pins allow up to eight devices to be controlled on a single bus.

The SE98B is available as the SE97B thermal sensor only.

勝特力材料 886-3-5753170
勝特力电子(上海) 86-21-34970699
勝特力电子(深圳) 86-755-83298787
[Http://www.100y.com.tw](http://www.100y.com.tw)

Table 1. Comparison of SE97 versus SE97B features

Feature	SE97	SE97B
JEDEC specification	old JEDEC specification	new JEDEC specification
Bit 8 '1' Thermal Sensor shutdown	no SMBus Timeout	SMBus Timeout 25 ms to 35 ms
Bit 8 '0' Thermal Sensor active	SMBus Timeout 25 ms to 35 ms	
I ² C-bus maximum frequency	400 kHz	
I ² C SCL and SDA V _{IL} /V _{IH} voltage levels	V _{IL(max)} = 0.3 × V _{DD} ; V _{IH(min)} = 0.7 × V _{DD}	
Capabilities bit 6 SMBus Timeout	set to 0	set to 1
EVENT pin operation	frozen	de-assert
Capabilities bit 7 $\overline{\text{EVENT}}$ pin	set to 0	set to 1
A0 pin is 10 V tolerant	yes	
Capabilities bit 5 VHV	set to 0	set to 1
I ² C spike suppression	50 ns	
I ² C input hysteresis	-	0.05 × V _{DD}
SE97 Device ID register	1010 0010	
Revision ID register	0000 0001	0000 0011
Temperature Sensor accuracy	Grade B	Improved Grade B
Power-On Reset (POR)	0.6 V	1.8 V
Temperature Sensor voltage range	3.0 V to 3.6 V	
EEPROM Write voltage range	3.0 V to 3.6 V	
EEPROM Read voltage range	1.7 V to 3.6 V	3.0 V to 3.6 V
2 mm × 3 mm × 0.8 mm package	assembly plant Hong Kong	assembly plant Bangkok (thicker die and leadframe)

2. Features

2.1 General features

- JEDEC (JC-42.4) DIMM temperature sensor plus 256-byte serial EEPROM for Serial Presence Detect (SPD)
- SDA open-drain output design for best operation in distributed multi-point applications
- Shutdown current: 0.1 μA (typ.) and 5.0 μA (max.)
- Power-on reset: 1.8 V (typ.)
- 2-wire interface: I²C-bus/SMBus compatible, 0 Hz to 400 kHz
- SMBus Alert Response Address and TIMEOUT 25 ms to 35 ms (programmable)
- ESD protection exceeds 2500 V HBM per JESD22-A114, 250 V MM per JESD22-A115, and 1000 V CDM per JESD22-C101
- Latch-up testing is done to JEDEC Standard JESD78 which exceeds 100 mA
- Available in HWSON8 package

2.2 Temperature sensor features

- 11-bit ADC Temperature-to-Digital converter with 0.125 °C resolution
- Voltage range: 3.0 V to 3.6 V
- Operating current: 250 μA (typ.) and 400 μA (max.)

- Programmable hysteresis threshold: off, 0 °C, 1.5 °C, 3 °C, 6 °C
- Over/under/critical temperature EVENT output
- B-grade accuracy:
 - ◆ ±0.5 °C/±1 °C (typ./max.) → +75 °C to +95 °C
 - ◆ ±1.0 °C/±2 °C (typ./max.) → +40 °C to +125 °C
 - ◆ ±2.0 °C/±3 °C (typ./max.) → -40 °C to +125 °C

2.3 Serial EEPROM features

- Read and write voltage range: 3.0 V to 3.6 V
- Operating current:
 - ◆ Write → 0.6 mA (typ.) for 3.5 ms (typ.)
 - ◆ Read → 100 µA (typ.)
- Organized as 1 block of 256 bytes (256 × 8)
- 100,000 write/erase cycles and 10 years of data retention
- Permanent and Reversible Software Write Protect
- Software Write Protection for the lower 128 bytes

3. Applications

- DDR2 and DDR3 memory modules
- Laptops, personal computers and servers
- Enterprise networking
- Hard disk drives and other PC peripherals

4. Ordering information

Table 2. Ordering information

Type number	Topside mark	Package		
		Name	Description	Version
SE97BTP ^[1]	97B	HWSON8	plastic thermal enhanced very very thin small outline package; no leads; 8 terminals; body 2 × 3 × 0.8 mm	SOT1069-2

[1] Industry standard 2 mm × 3 mm × 0.8 mm package to JEDEC WCE-3, PSON8 in 8 mm × 4 mm pitch tape 4 k quantity reels.

勝特力材料 886-3-5753170
 勝特力电子(上海) 86-21-34970699
 勝特力电子(深圳) 86-755-83298787
 Http://www.100y.com.tw

5. Block diagram

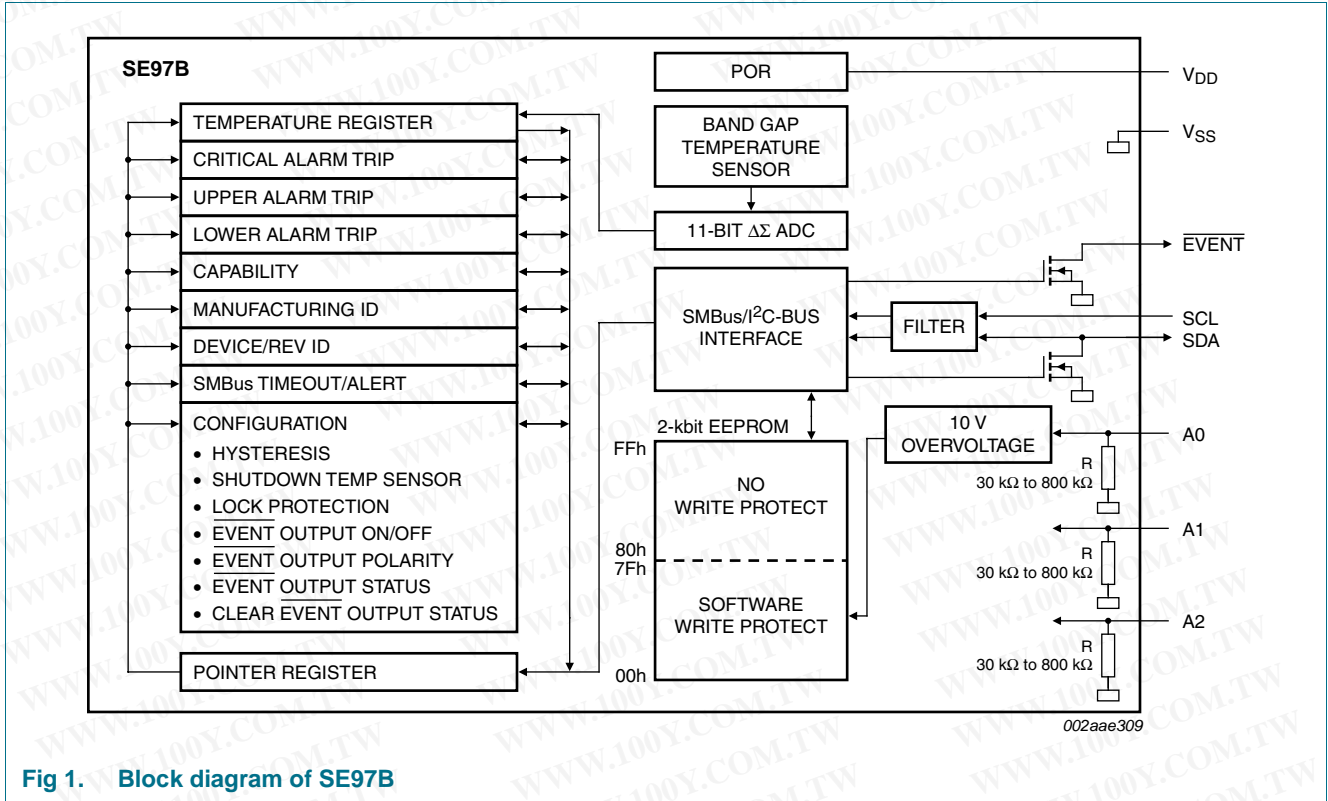
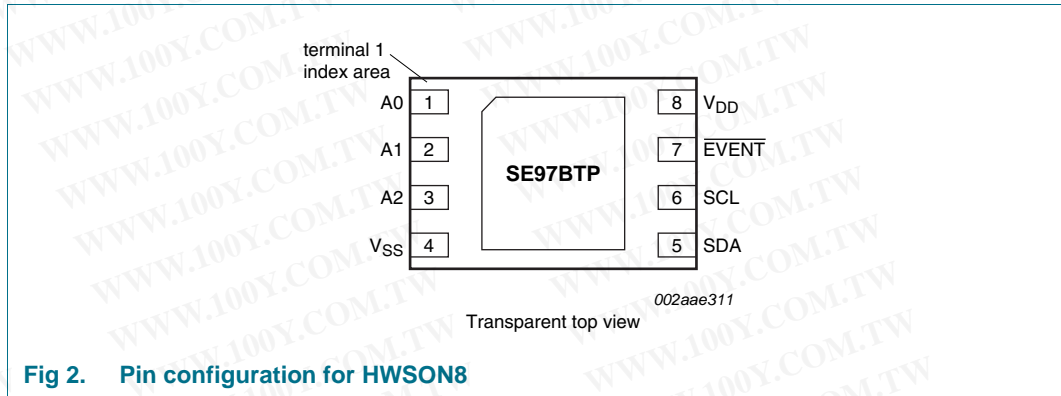

Fig 1. Block diagram of SE97B

勝特力材料 886-3-5753170
 勝特力电子(上海) 86-21-34970699
 勝特力电子(深圳) 86-755-83298787
[Http://www.100y.com.tw](http://www.100y.com.tw)

6. Pinning information

6.1 Pinning



6.2 Pin description

Table 3. Pin description

Symbol	Pin	Type	Description
A0	1	I	I ² C-bus/SMBus slave address bit 0 with internal pull-down. This input is overvoltage tolerant to support software write protection.
A1	2	I	I ² C-bus/SMBus slave address bit 1 with internal pull-down
A2	3	I	I ² C-bus/SMBus slave address bit 2 with internal pull-down
V _{SS}	4	ground	device ground
SDA	5	I/O	SMBus/I ² C-bus serial data input/output (open-drain). Must have external pull-up resistor.
SCL	6	I	SMBus/I ² C-bus serial clock input/output (open-drain). Must have external pull-up resistor.
EVENT	7	O	Thermal alarm output for high/low and critical temperature limit (open-drain). Must have external pull-up resistor.
V _{DD}	8	power	device power supply (3.0 V to 3.6 V)

勝特力材料 886-3-5753170
 勝特力电子(上海) 86-21-34970699
 勝特力电子(深圳) 86-755-83298787
[Http://www.100y.com.tw](http://www.100y.com.tw)

7. Functional description

7.1 Serial bus interface

The SE97B communicates with a host controller by means of the 2-wire serial bus (I²C-bus/SMBus) that consists of a serial clock (SCL) and serial data (SDA) signals. The device supports SMBus, I²C-bus Standard-mode and Fast-mode. The I²C-bus standard speed is defined to have bus speeds from 0 Hz to 100 kHz, I²C-bus fast speed from 0 Hz to 400 kHz, and the SMBus is from 10 kHz to 100 kHz. The host or bus master generates the SCL signal, and the SE97B uses the SCL signal to receive or send data on the SDA line. Data transfer is serial, bidirectional, and is one byte at a time with the Most Significant Bit (MSB) transferred first. Since SCL and SDA are open-drain, pull-up resistors must be installed on these pins.

7.2 Slave address

The SE97B uses a 4-bit fixed and 3-bit programmable (A0, A1 and A2) 7-bit slave address that allows a total of eight devices to coexist on the same bus. The A0, A1 and A2 pins are pulled LOW internally. The A0 pin is also overvoltage tolerant supporting 10 V software write protect. When it is driven higher than 7.0 V, writing a special command would put the EEPROM in reversible write protect mode (see [Section 7.10.2 "Memory Protection"](#)). Each pin is sampled at the start of each I²C-bus/SMBus access. The temperature sensor's fixed address is '0011b'. The EEPROM's fixed address for the normal EEPROM read/write is '1010b', and for EEPROM software protection command is '0110b'. Refer to [Figure 3](#).

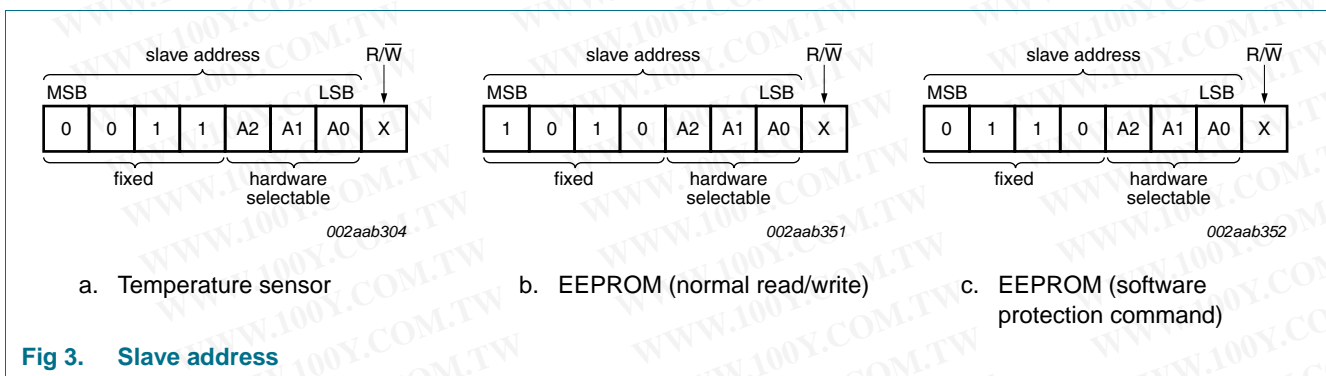

Fig 3. Slave address

勝特力材料 886-3-5753170
 勝特力电子(上海) 86-21-34970699
 勝特力电子(深圳) 86-755-83298787
[Http://www.100y.com.tw](http://www.100y.com.tw)

7.3 $\overline{\text{EVENT}}$ output condition

The $\overline{\text{EVENT}}$ output indicates conditions such as the temperature crossing a predefined boundary. The $\overline{\text{EVENT}}$ modes are very configurable and selected using the configuration register (CONFIG). The interrupt mode or comparator mode is selected using CONFIG[0], using either TCrit/UPPER/LOWER or TCrit only temperature bands (CONFIG[2]) as modified by hysteresis (CONFIG[10:9]). The UPPER/LOWER (CONFIG[6]) and TCrit (CONFIG[7]) bands can be locked. Figure 4 shows an example of the measured temperature versus time, with the corresponding behavior of the $\overline{\text{EVENT}}$ output in each of these modes.

Upon device power-up, the default condition for the $\overline{\text{EVENT}}$ output is high-impedance to prevent spurious or unwanted alarms, but can be later enabled (CONFIG[3]). CONFIG[3] does not have to be cleared (e.g., set back to (0)) before changing CONFIG[2] or CONFIG[0]. $\overline{\text{EVENT}}$ output polarity can be set to active HIGH or active LOW (CONFIG[1]). $\overline{\text{EVENT}}$ status can be read (CONFIG[4]) and cleared (CONFIG[5]).

If the $\overline{\text{EVENT}}$ output is enabled (CONFIG[3] = 1) and the part is switched between Interrupt mode and Comparator mode or vice versa, the $\overline{\text{EVENT}}$ output may glitch during the change.

If the device enters Shutdown mode (CONFIG[8]) with asserted $\overline{\text{EVENT}}$ output, the output either de-asserts (default) or remains asserted (frozen) depending on SMBUS[4].

7.3.1 $\overline{\text{EVENT}}$ pin output voltage levels and resistor sizing

The $\overline{\text{EVENT}}$ open-drain output is typically pulled up to a voltage level from 0.9 V to 3.6 V with an external pull-up resistor, but there is no real lower limit on the pull-up voltage for the $\overline{\text{EVENT}}$ pin since it is simply an open-drain NMOS pull-down output. It could be pulled up to 0.1 V and would not affect the output. From the system perspective, there will be a practical limit. That limit will be the voltage necessary for the device monitoring the interrupt pin to detect a HIGH on its input. A possible practical limit for a CMOS input would be 0.4 V. Another thing to consider is the value of the pull-up resistor. When a low supply voltage is applied to the drain (through the pull-up resistor) it is important to use a higher value pull-up resistor, to allow a larger maximum signal swing on the $\overline{\text{EVENT}}$ pin.

勝特力材料 886-3-5753170
勝特力电子(上海) 86-21-34970699
勝特力电子(深圳) 86-755-83298787
[Http://www.100y.com.tw](http://www.100y.com.tw)

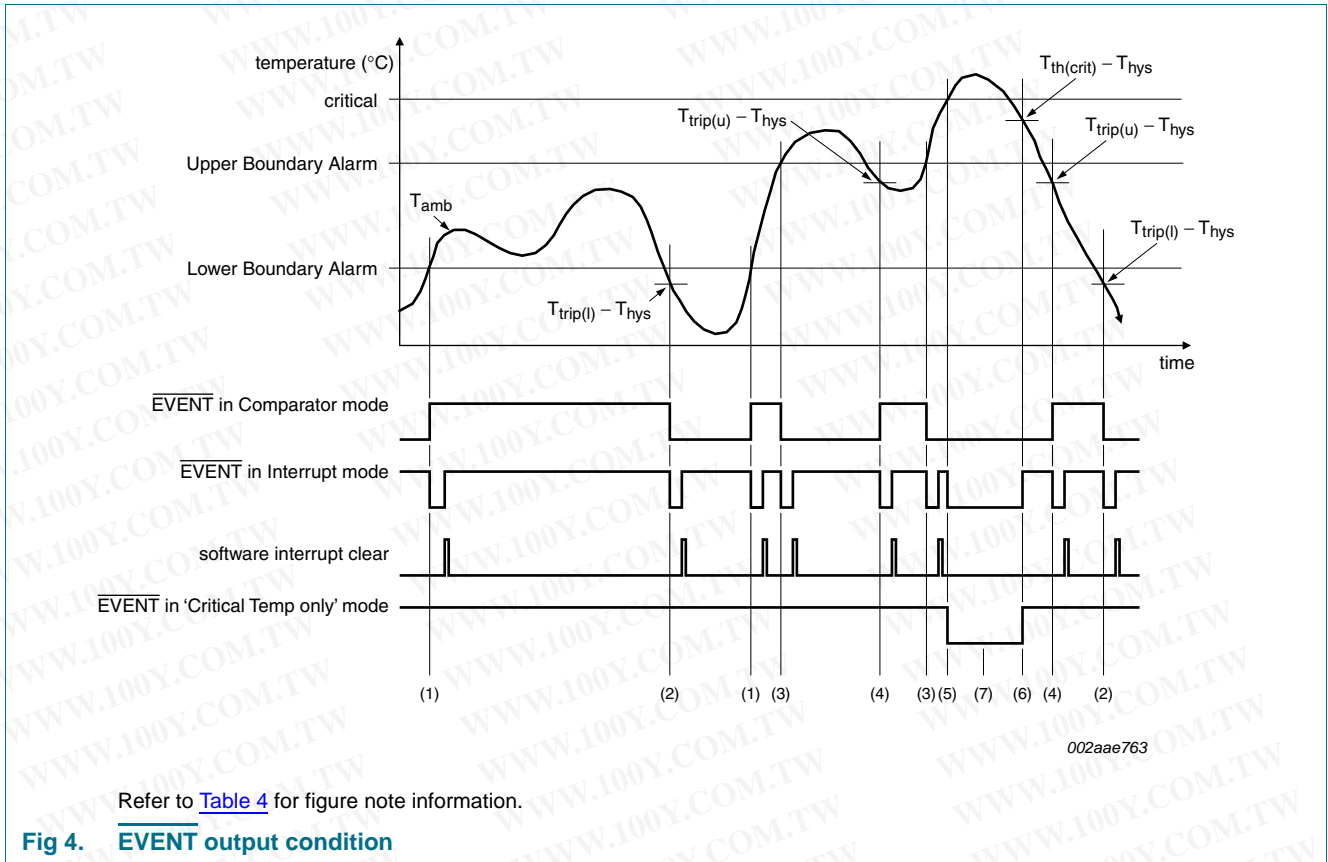

Table 4. EVENT output condition

Figure note	EVENT output boundary conditions	EVENT output			Temperature Register Status bits		
		Comparator mode	Interrupt mode	Critical Temp only mode	Bit 15 Above Critical Trip	Bit 14 Above Alarm Window	Bit 13 Below Alarm Window
(1)	$T_{amb} \geq T_{trip(l)}$	H	L	H	0	0	0
(2)	$T_{amb} < T_{trip(l)} - T_{hys}$	L	L	H	0	0	1
(3)	$T_{amb} > T_{trip(u)}$	L	L	H	0	1	0
(4)	$T_{amb} \leq T_{trip(u)} - T_{hys}$	H	L	H	0	0	0
(5)	$T_{amb} \geq T_{th(crit)}$	L	L	L	1	1	0
(6)	$T_{amb} < T_{th(crit)} - T_{hys}$	L	H	H	0	1	0
(7)	Table note [1]						

[1] Between $T_{amb} \geq T_{th(crit)}$ and $T_{amb} < T_{th(crit)} - T_{hys}$ the $\overline{\text{EVENT}}$ output is in Comparator mode and bit 0 of CONFIG ($\overline{\text{EVENT}}$ output mode) is ignored.

勝特力材料 886-3-5753170
 勝特力电子(上海) 86-21-34970699
 勝特力电子(深圳) 86-755-83298787
[Http://www.100y.com.tw](http://www.100y.com.tw)

7.3.2 $\overline{\text{EVENT}}$ thresholds

7.3.2.1 Alarm window

The device provides a comparison window with an UPPER trip point and a LOWER trip point, programmed through the Upper Boundary Alarm Trip register (02h), and Lower Boundary Alarm Trip register (03h). The Upper Boundary Alarm Trip register holds the upper temperature trip point, while the Lower Boundary Alarm Trip register holds the lower temperature trip point as modified by hysteresis as programmed in the Configuration register. When enabled, the $\overline{\text{EVENT}}$ output triggers whenever entering or exiting (crossing above or below) the alarm window.

- **Advisory note:**

- NXP device: The $\overline{\text{EVENT}}$ output can be cleared through the clear EVENT bit or SMBus Alert Response Address (ARA).
- Competitor device: The $\overline{\text{EVENT}}$ output can be cleared only through the clear EVENT bit.
- Work-around: Only clear $\overline{\text{EVENT}}$ output using the EVENT bit if both NXP and competitor devices are used.

The Upper Boundary Alarm Trip should always be set above the Lower Boundary Alarm Trip.

The alarm window limit is immediately compared with the temperature register even if it has not been recently updated (e.g., device has been in standby) when the $\overline{\text{EVENT}}$ is turned on (CONFIG[3]).

Consider waiting one conversion cycle (125 ms) after setting the alarm window limit before enabling the $\overline{\text{EVENT}}$ output/comparing the alarm window limit with the temperature register to ensure that there is correct data in the temperature register.

If SMBUS[2] is set, then the alarm window limit will only be compared to the Temperature register after it has been updated when $\overline{\text{EVENT}}$ is turned on.

7.3.2.2 Critical trip

The $T_{th(crit)}$ temperature setting is programmed in the Critical Alarm Trip register (04h) as modified by hysteresis as programmed in the Configuration register. When the temperature reaches the critical temperature value in this register (and $\overline{\text{EVENT}}$ is enabled), the $\overline{\text{EVENT}}$ output asserts and cannot be de-asserted until the temperature drops below the critical temperature threshold. The Event cannot be cleared through the clear EVENT bit or SMBus Alert.

The Critical Alarm Trip should always be set above the Upper Boundary Alarm Trip.

The critical trip limit is immediately compared with the temperature register even if it has not been recently updated (e.g., device has been in standby) when the $\overline{\text{EVENT}}$ is turned on (CONFIG[3]).

Consider waiting one conversion cycle (125 ms) after setting the critical trip limit before enabling the $\overline{\text{EVENT}}$ output/comparing the critical trip limit with the temperature register to ensure that there is correct data in the temperature register.

If SMBUS[2] is set, then the alarm window limit will only be compared to the Temperature register after it has been updated when $\overline{\text{EVENT}}$ is turned on.

7.3.3 $\overline{\text{EVENT}}$ operation modes

7.3.3.1 Comparator mode

In comparator mode, the $\overline{\text{EVENT}}$ output behaves like a window-comparator output that asserts when the temperature is outside the window (e.g., above the value programmed in the Upper Boundary Alarm Trip register or below the value programmed in the Lower Boundary Alarm Trip register or above the Critical Alarm Trip register if $T_{th(crit)}$ only is selected). Reads/writes on these registers do not affect the $\overline{\text{EVENT}}$ output in comparator mode. The $\overline{\text{EVENT}}$ signal remains asserted until the temperature goes inside the alarm window or the window thresholds are reprogrammed so that the current temperature is within the alarm window.

The comparator mode is useful for thermostat-type applications, such as turning on a cooling fan or triggering a system shutdown when the temperature exceeds a safe operating range.

7.3.3.2 Interrupt mode

In interrupt mode, $\overline{\text{EVENT}}$ asserts whenever the temperature crosses an alarm window threshold. After such an event occurs, writing a 1 to the clear event bit in the configuration register de-asserts the $\overline{\text{EVENT}}$ output until the next trigger condition occurs.

In interrupt mode, $\overline{\text{EVENT}}$ asserts when the temperature crosses the alarm upper boundary. If the $\overline{\text{EVENT}}$ output is cleared and the temperature continues to increase until it crosses the critical temperature threshold, $\overline{\text{EVENT}}$ asserts again. Because the temperature is greater than the critical temperature threshold, a clear event command does not clear the $\overline{\text{EVENT}}$ output. Once the temperature drops below the critical temperature, $\overline{\text{EVENT}}$ de-asserts immediately.

If the $\overline{\text{EVENT}}$ output is not cleared before or when the temperature is in the critical temperature threshold, $\overline{\text{EVENT}}$ will remain asserted after the temperature drops below the critical temperature until a clear event command.

7.3.3.3 Switching between Comparator mode and Interrupt mode

When the part is in Comparator mode and the temperature windows are set such that the BAW bit is set and the $\overline{\text{EVENT}}$ pin asserted (EventOutputControl = 1) and the part is switched to Interrupt mode, the $\overline{\text{EVENT}}$ is de-asserted.

勝特力材料 886-3-5753170
勝特力电子(上海) 86-21-34970699
勝特力电子(深圳) 86-755-83298787
[Http://www.100y.com.tw](http://www.100y.com.tw)

7.4 Conversion rate

The conversion time is the amount of time required for the ADC to complete a temperature measurement for the local temperature sensor. The conversion rate is the inverse of the conversion period which describes the number of cycles the temperature measurement completes in one second—the faster the conversion rate, the faster the temperature reading is updated. The SE97B's conversion rate is at least 8 Hz or 125 ms.

7.4.1 What temperature is read when conversion is in progress

The SE97B has been designed to ensure a valid temperature is always available. When a read to the temperature register is initiated through the SMBus, the device checks to see if the temperature conversion process (Analog-to-Digital conversion) is complete and a new temperature is available:

- If the temperature conversion process is complete, then the new temperature value is sent out on the SMBus.
- If the temperature conversion process is **not** complete, then the previous temperature value is sent out on the SMBus.

It is possible that while SMBus Master is reading the temperature register, a new temperature conversion completes. However, this will not affect the data (MSB or LSB) that is being shifted out. On the next read of the temperature register, the new temperature value will be shifted out.

7.5 Power-up default condition

After power-on, the SE97B is initialized to the following default condition:

- Starts monitoring local sensor
- $\overline{\text{EVENT}}$ register is cleared; $\overline{\text{EVENT}}$ output is pulled HIGH by external pull-ups
- $\overline{\text{EVENT}}$ hysteresis is defaulted to 0 °C
- Command pointer is defaulted to '00h'
- Critical Temp, Alarm Temperature Upper and Lower Boundary Trip register are defaulted to 0 °C
- Capability register is defaulted to '00F7h' for the B-grade and VHV capability, $\overline{\text{EVENT}}$ de-asserted and SMBus TIMEOUT between 25 ms and 35 ms enabled.
- Operational mode: comparator
- SMBus register is defaulted to '21h'

7.6 Device initialization

SE97B temperature sensors have programmable registers, which, upon power-up, default to zero. The open-drain $\overline{\text{EVENT}}$ output is default to being disabled, comparator mode and active LOW. The alarm trigger registers default to being unprotected. The configuration registers, upper and lower alarm boundary registers and critical temperature window are defaulted to zero and need to be programmed to the desired values. SMBus TIMEOUT feature defaults to being enabled and can be programmed to disable. These registers are required to be initialized before the device can properly function. Except for the SPD, which does not have any programmable registers, and does not need to be initialized.

Table 5 shows the default values and the example value to be programmed to these registers.

Table 5. Registers to be initialized

Register	Default value	Example value	Description
01h	0000h	0209h	Configuration register <ul style="list-style-type: none"> • hysteresis = 1.5 °C • $\overline{\text{EVENT}}$ output = Interrupt mode • $\overline{\text{EVENT}}$ output is enabled
02h	0000h	0550h	Upper Boundary Alarm Trip register = 85 °C
03h	0000h	1F40h	Lower Boundary Alarm Trip register = -20 °C
04h	0000h	05F0h	Critical Alarm Trip register = 95 °C
22h	21h	21h	SMBus register = no change

7.7 SMBus TIMEOUT

The SE97B supports SMBus TIMEOUT feature. If the host holds SCL LOW more than 35 ms, the SE97B would reset its internal state machine to the bus IDLE state to prevent a system bus hang-up. This feature is turned on by default and release SDA. The SMBus TIMEOUT can be disabled by writing a '1' to SMBUS[7].

Remark: When SMBus TIMEOUT is enabled, the I²C-bus minimum bus speed is limited by the SMBus TIMEOUT specification limit of 10 kHz.

The SE97B has no SCL driver, so it cannot hold the SCL line LOW.

7.8 SMBus Alert Response Address (ARA)

The SE97B supports SMBus ALERT when it is programmed for the Interrupt mode and when the $\overline{\text{EVENT}}$ polarity bit is set to '0'. In Comparator mode or when the $\overline{\text{EVENT}}$ polarity bit is set to '1', the SMBus ALERT address is not acknowledged. The $\overline{\text{EVENT}}$ pin can be ANDed with other $\overline{\text{EVENT}}$ or interrupt signals from other slave devices to signal their intention to communicate with the host controller. When the host detects $\overline{\text{EVENT}}$ or other interrupt signal LOW, it issues an ARA to which a slave device would respond with its address. When there are multiple slave devices generating an ALERT the SE97B performs bus arbitration with the other slaves. If it wins the bus, it responds to the ARA and then clears the $\overline{\text{EVENT}}$ pin. This feature is turned off by default and can be enabled by writing a '0' to SMBUS[0].

Remark: Either in comparator mode or when the SE97B crosses the critical temperature, the host must also read the $\overline{\text{EVENT}}$ status bit and provide remedy to the situation by bringing the temperature to within the alarm window or below the critical temperature if that bit is set. Otherwise, the $\overline{\text{EVENT}}$ pin will not get de-asserted.

勝特力材料 886-3-5753170
 勝特力电子(上海) 86-21-34970699
 勝特力电子(深圳) 86-755-83298787
[Http://www.100y.com.tw](http://www.100y.com.tw)

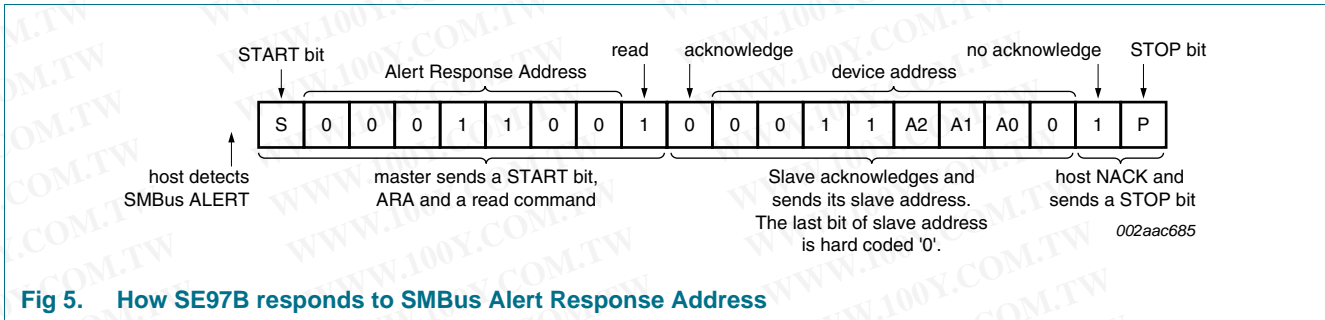

Fig 5. How SE97B responds to SMBus Alert Response Address

7.9 SMBus/I²C-bus interface

The data registers in this device are selected by the Pointer Register. At power-up, the Pointer Register is set to '00h', the location for the Capability Register. The Pointer Register latches the last location to which it was set. Each data register falls into one of three types of user accessibility:

- Read only
- Write only
- Write/Read same address

A 'write' to this device will always include the address byte and the pointer byte. A write to any register other than the Pointer register requires two data bytes.

Reading this device can take place either of two ways:

- If the location latched in the Pointer register is correct (most of the time it is expected that the Pointer register will point to one of the Temperature register (as it will be the data most frequently read), then the read can simply consist of an address byte, followed by retrieving the two data bytes.
- If the Pointer register needs to be set, then an address byte, pointer byte, repeat START, and another address byte will accomplish a read.

The data byte has the most significant bit first. At the end of a read, this device can accept either Acknowledge (ACK) or No Acknowledge (NACK) from the Master (No Acknowledge is typically used as a signal for the slave that the Master has read its last byte). It takes this device 125 ms to measure the temperature. Refer to timing diagrams [Figure 6](#) to [Figure 9](#) for how to program the device.

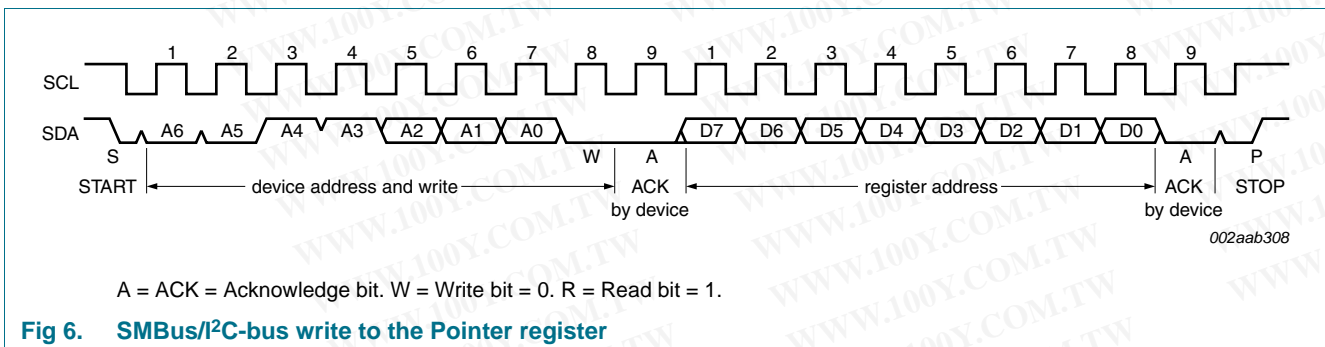

A = ACK = Acknowledge bit. W = Write bit = 0. R = Read bit = 1.

Fig 6. SMBus/I²C-bus write to the Pointer register

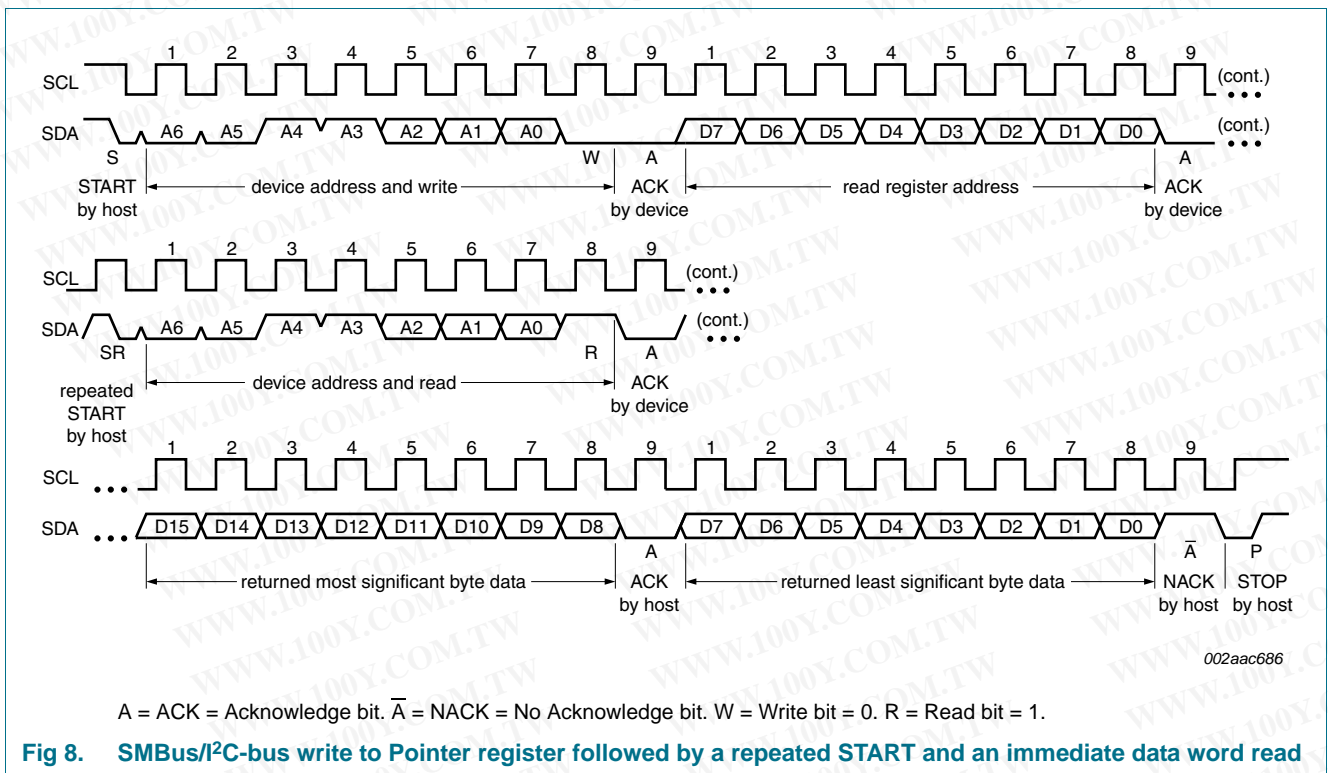
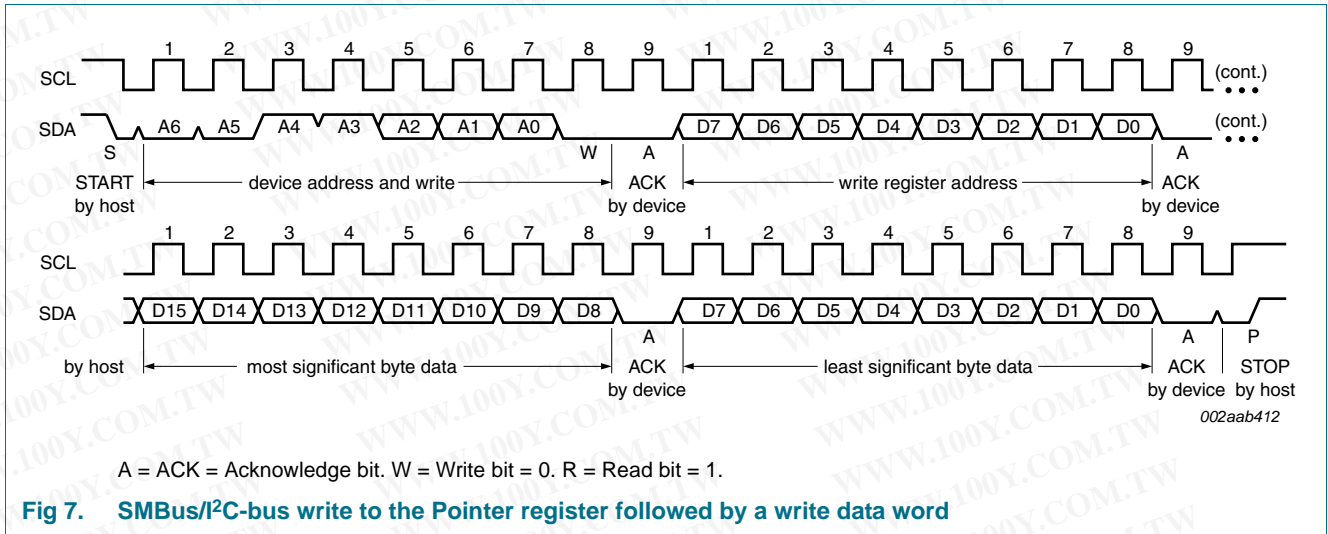

勝特力材料 886-3-5753170
 勝特力电子(上海) 86-21-34970699
 勝特力电子(深圳) 86-755-83298787
[Http://www.100y.com.tw](http://www.100y.com.tw)

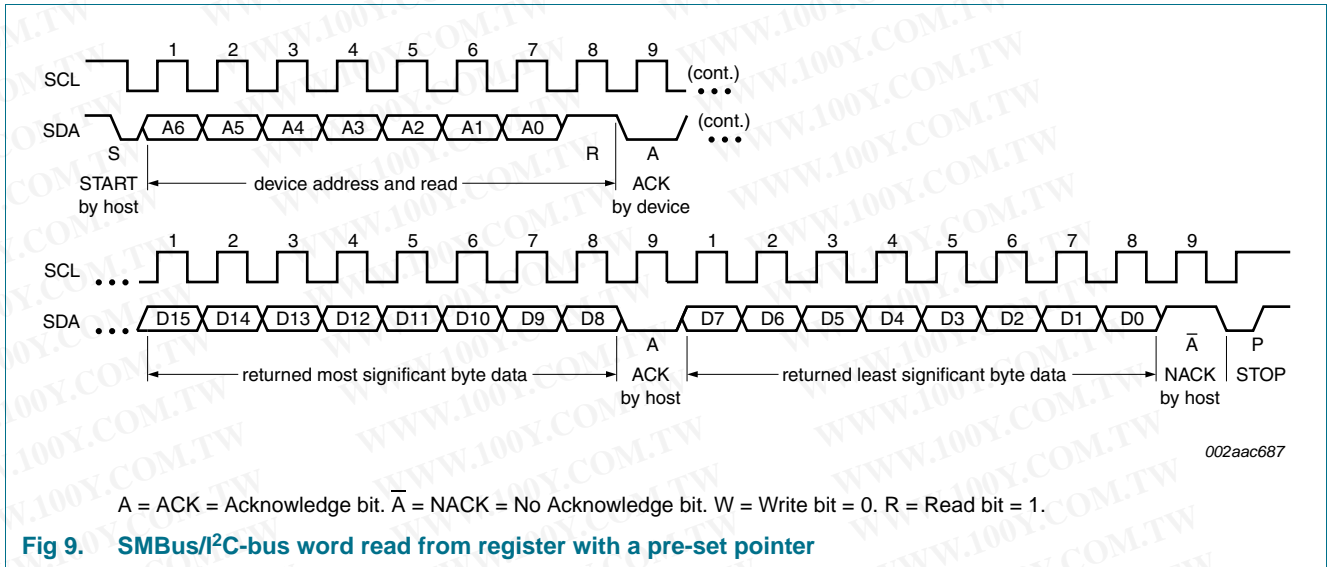

7.10 EEPROM operation

The 2-kbit EEPROM is organized as either 256 bytes of 8 bits each (byte mode), or 16 pages of 16 bytes each (page mode). Accessing the EEPROM in byte mode or page mode is automatic; partial page write of 2 bytes, 4 bytes, or 8 bytes is also supported. Communication with the EEPROM is via the 2-wire serial I²C-bus or SMBus. [Figure 10](#) provides an overview of the EEPROM partitioning.

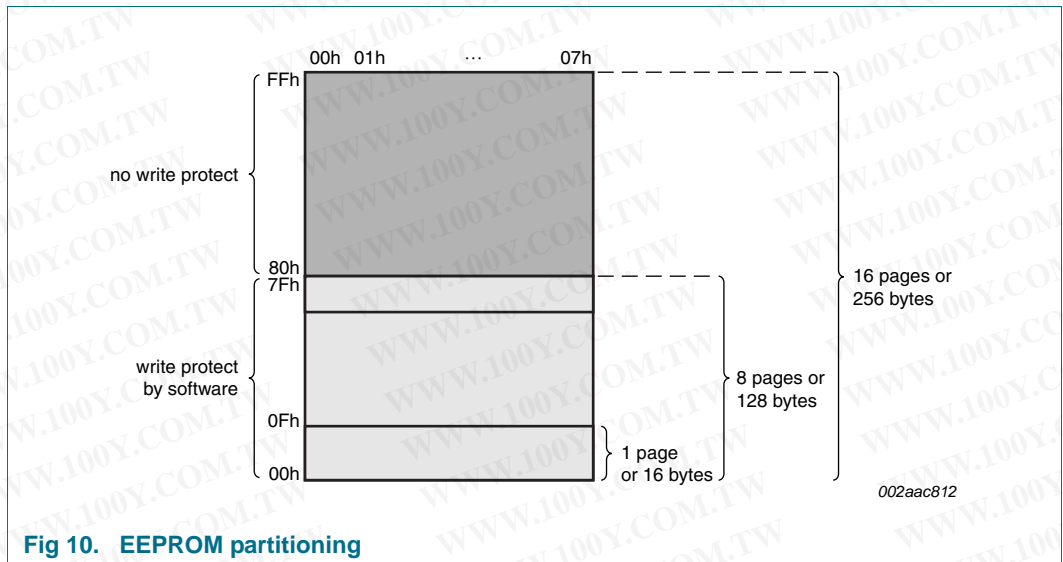

勝特力材料 886-3-5753170
 勝特力电子(上海) 86-21-34970699
 勝特力电子(深圳) 86-755-83298787
[Http://www.100y.com.tw](http://www.100y.com.tw)

7.10.1 Write operations

7.10.1.1 Byte Write

In Byte Write mode the master creates a START condition and then broadcasts the slave address, byte address, and data to be written. The slave acknowledges all 3 bytes by pulling down the SDA line during the ninth clock cycle following each byte. The master creates a STOP condition after the last ACK from the slave, which then starts the internal write operation (see Figure 11). During internal write, the slave will ignore any read/write request from the master.

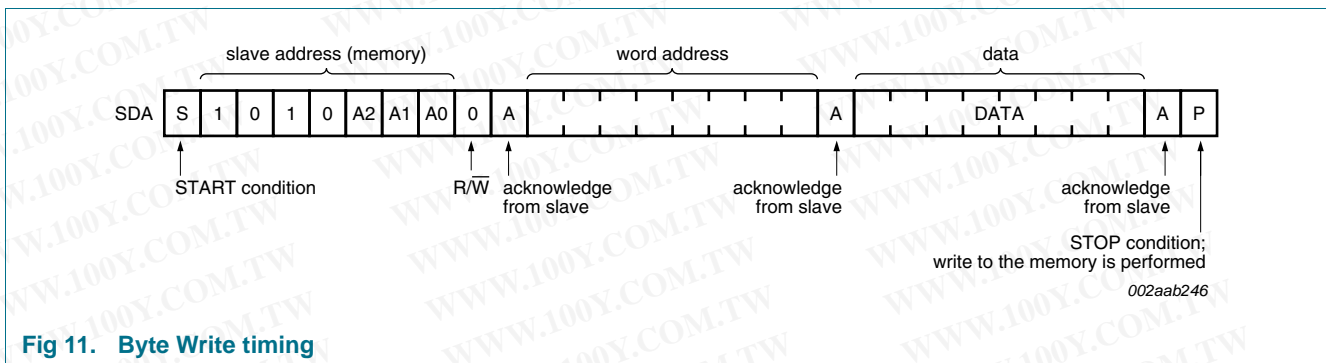

Fig 11. Byte Write timing

7.10.1.2 Page Write

The SE97B contains 256 bytes of data, arranged in 16 pages of 16 bytes each. The page is selected by the four Most Significant Bits (MSB) of the address byte presented to the device after the slave address, while the four Least Significant Bits (LSB) point to the byte within the page. By loading more than one data byte into the device, up to an entire page can be written in one write cycle (see Figure 12). The internal byte address counter will increment automatically after each data byte. If the master transmits more than 16 data bytes, then earlier bytes will be overwritten by later bytes in a wrap-around fashion within the selected page. The internal write cycle is started following the STOP condition created by the master.

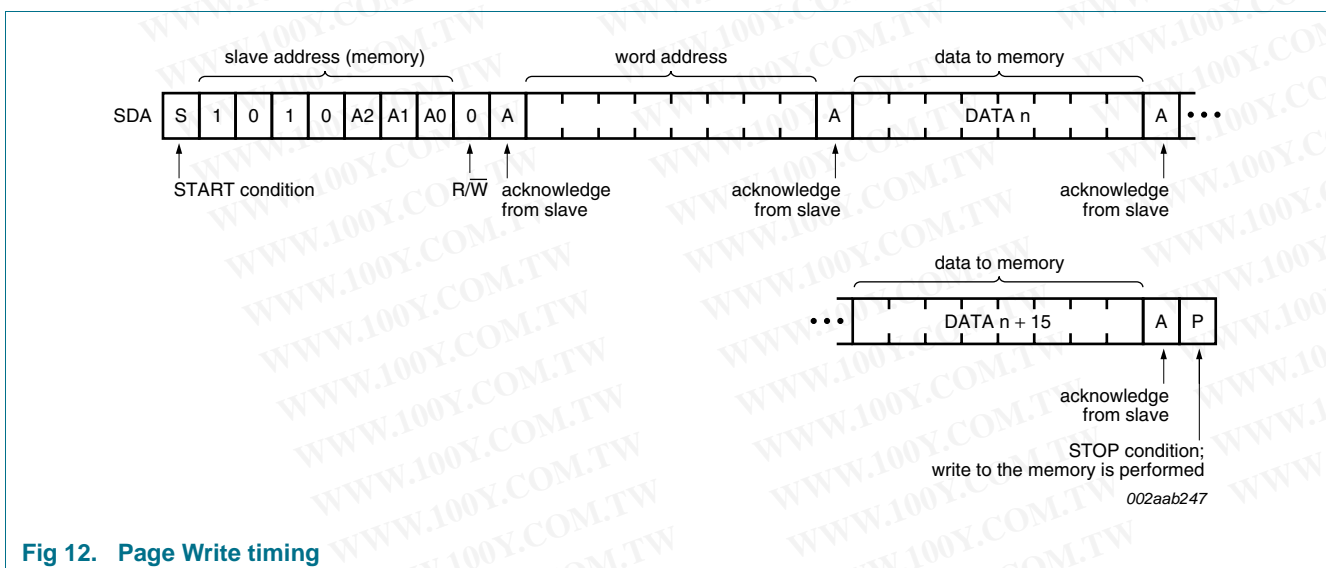

Fig 12. Page Write timing

7.10.1.3 Acknowledge polling

Acknowledge polling can be used to determine if the SE97B is busy writing or is ready to accept commands. Polling is implemented by sending a 'Selective Read' command (described in [Section 7.10.3 "Read operations"](#)) to the device. The SE97B will not acknowledge the slave address as long as internal write is in progress.

7.10.2 Memory Protection

The lower half (the first 128 bytes) of the memory can be write protected by special EEPROM commands without an external control pin. The SE97B features three types of memory write protection instructions, and three respective read Protection instructions. The level of write-protection (set or clear) that has been defined using these instructions remained defined even after power cycle.

The memory protection commands are:

- Permanent Write Protection (PWP)
- Reversible Write Protection (RWP)
- Clear Write Protection (CWP)
- Read Permanent Write Protection (RPWP)
- Read Reversible Write Protection (RRWP)
- Read Clear Write Protection (RCWP)

[Table 6](#) is the summary for normal and memory protection instructions.

Table 6. EEPROM commands summary

Command	Fixed address				Hardware selectable address			R/W
	Bit 7 ^[1]	Bit 6	Bit 5	Bit 4	Bit 3	Bit 2	Bit 1	
Normal EEPROM read/write	1	0	1	0	A2	A1	A0	R/W
Reversible Write Protection (RWP)	0	1	1	0	V _{SS}	V _{SS}	V _{I(ov)} ^[2]	0
Clear Reversible Write Protection (CRWP)	0	1	1	0	V _{SS}	V _{DD}	V _{I(ov)} ^[2]	0
Permanent Write Protection (PWP) ^[3]	0	1	1	0	A2	A1	A0	0
Read RWP	0	1	1	0	V _{SS}	V _{SS}	V _{I(ov)} ^[2]	1
Read CRWP	0	1	1	0	V _{SS}	V _{DD}	V _{I(ov)} ^[2]	1
Read PWP	0	1	1	0	A2	A1	A0	1

[1] The most significant bit, bit 7, is sent first.

[2] V_{I(ov)} ranges from 7.0 V to 10 V.

[3] A0, A1, and A2 are compared against the respective external pins on the SE97B. Do not apply V_{I(ov)} to the A0 pin during Normal EEPROM read/write, Permanent Write Protection (PWP) and Read PWP.

This special EEPROM command consists of a unique 4-bit fixed address (0110b) and the voltage level applied on the 3-bit hardware address. Normally, to address the memory array, the 4-bit fixed address is '1010b'. To access the memory protection settings, the 4-bit fixed address is '0110b'. [Figure 13](#) and [Figure 14](#) show the write and read protection sequence, respectively.

Up to eight memory devices can be connected on a single I²C-bus. Each one is given a 3-bit on the hardware selectable address (A2, A1, A0) inputs. The device only responds when the 4-bit fixed and hardware selectable bits are matched. The 8th bit is the read/write bit. This bit is set to 1 or 0 for read and write protection, respectively.

The corresponding device acknowledges during the ninth bit time when there is a match on the 7-bit address.

The device does not acknowledge when there is no match on the 7-bit address or when the device is already in permanent write protection mode and is programmed with any write protection instructions (i.e., PWP, RWP, CWP).

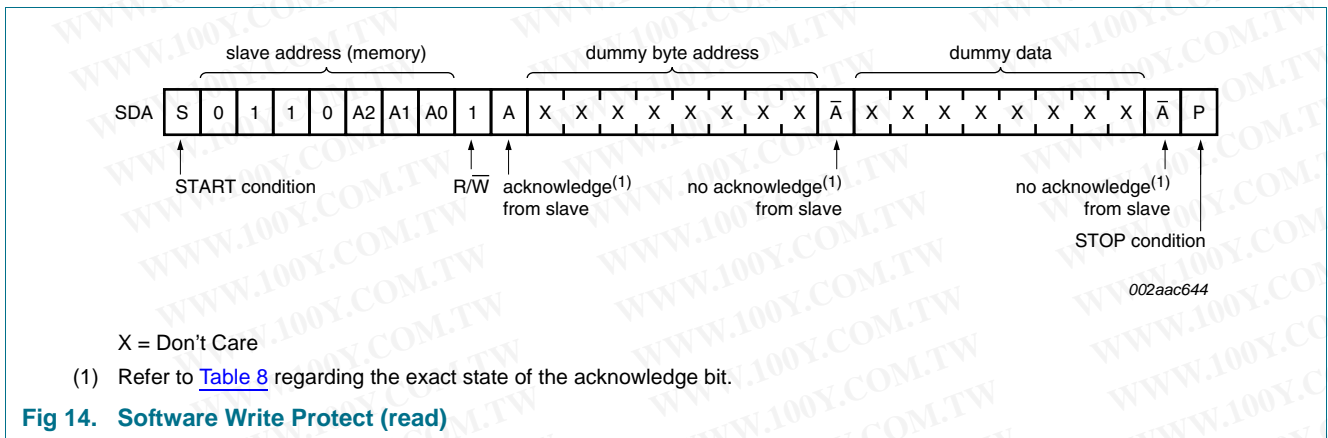
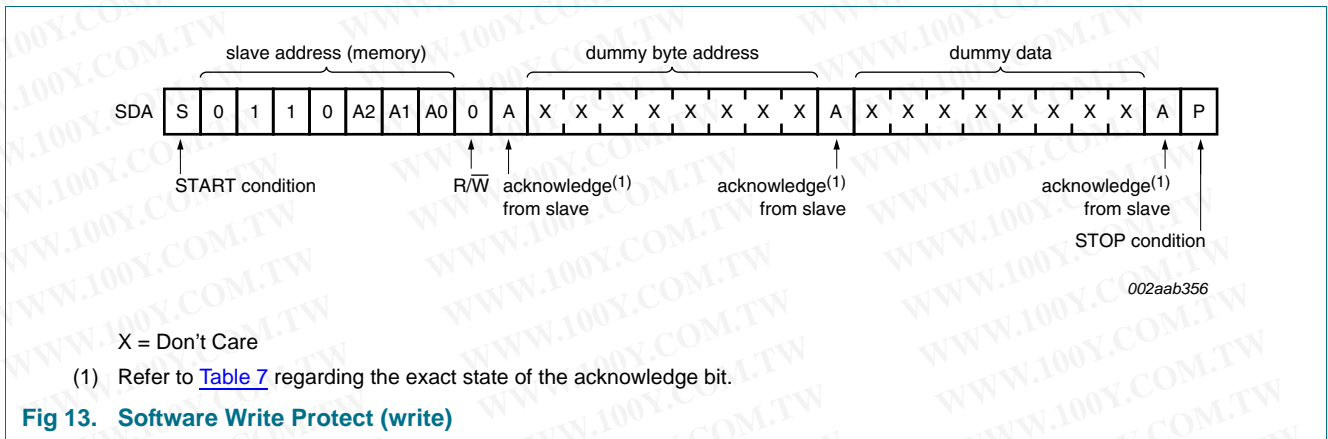

7.10.2.1 Permanent Write Protection (PWP)

If the software write-protection has been set with the PWP instruction, the first 128 bytes of the memory are permanently write-protected. This write-protection cannot be cleared by any instruction, or by power-cycling the device. Also, once the PWP instruction has been successfully executed, the device no longer acknowledges any instruction (with 4-bit fixed address of 0110b) to access the write-protection settings.

勝特力材料 886-3-5753170
 勝特力电子(上海) 86-21-34970699
 勝特力电子(深圳) 86-755-83298787
 Http://www.100y.com.tw

7.10.2.2 Reversible Write Protection (RWP) and Clear Reversible Write Protection (CRWP)

If the software write-protection has been set with the RWP instruction, it can be cleared again with a CRWP instruction.

The two instructions, RWP and CRWP have the same format as a Byte Write instruction, but with a different setting for the hardware address pins (as shown in Table 6). Like the Byte Write instruction, it is followed by an address byte and a data byte, but in this case the contents are all 'Don't Care' (Figure 13). Another difference is that the voltage, $V_{I(ov)}$, must be applied on the A0 pin, and specific logical levels must be applied on the other two (A1 and A2), as shown in Table 6.

Table 7. Acknowledge when writing data or defining write protection
Instructions with R/\overline{W} bit = 0.

Status	Instruction	ACK	Address	ACK	Data byte	ACK	Write cycle (t_w)
Permanently protected	PWP, RWP or CRWP	NACK	not significant	NACK	not significant	NACK	no
	page or byte write in lower 128 bytes	ACK	address	ACK	data	NACK	no
Protected with RWP	RWP	NACK	not significant	NACK	not significant	NACK	no
	CRWP	ACK	not significant	ACK	not significant	ACK	yes
	PWP	ACK	not significant	ACK	not significant	ACK	yes
	page or byte write in lower 128 bytes	ACK	address	ACK	data	NACK	no
Not protected	PWP or RWP	ACK	not significant	ACK	not significant	ACK	yes
	CRWP	ACK	not significant	ACK	not significant	ACK	no
	page or byte write	ACK	address	ACK	data	ACK	yes

7.10.2.3 Read Permanent Write Protection (RPWP), Read Reversible Write Protection (RRWP), and Read Clear Reversible Write Protection (RCRWP)

Read PWP, RWP, and CRWP allow the SE97B to be read in write protection mode. The instruction format is the same as that of the write protection except that the 8th bit, R/\overline{W} , is set to 1. Figure 14 shows the instruction format, while Table 8 shows the responses when the instructions are issued.

Table 8. Acknowledge when reading the write protection
Instructions with R/\overline{W} bit = 1.

Status	Instruction	ACK	Address	ACK	Data byte	ACK
Permanently protected	RPWP, RRWP or RCRWP	NACK	not significant	NACK	not significant	NACK
Protected with RWP	RRWP	NACK	not significant	NACK	not significant	NACK
	RCRWP	ACK	not significant	NACK	not significant	NACK
	RPWP	ACK	not significant	NACK	not significant	NACK
Not protected	RPWP, RRWP or RCRWP	ACK	not significant	NACK	not significant	NACK

勝特力材料 886-3-5753170
 勝特力电子(上海) 86-21-34970699
 勝特力电子(深圳) 86-755-83298787
[Http://www.100y.com.tw](http://www.100y.com.tw)

7.10.3 Read operations

7.10.3.1 Current address read

In Standby mode, the SE97B internal address counter points to the data byte immediately following the last byte accessed by a previous operation. If the 'previous' byte was the last byte in memory, then the address counter will point to the first memory byte, and so on. If the SE97B decodes a slave address with a '1' in the R/W bit position (Figure 15), it will issue an Acknowledge in the ninth clock cycle and will then transmit the data byte being pointed at by the address counter. The master can then stop further transmission by issuing a No Acknowledge on the ninth bit then followed by a STOP condition.

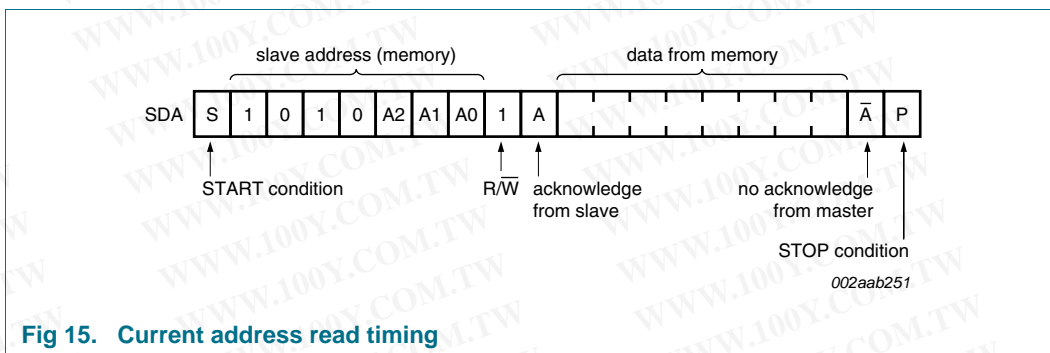

Fig 15. Current address read timing

7.10.3.2 Selective read

The read operation can also be started at an address different from the one stored in the address counter. The address counter can be 'initialized' by performing a 'dummy' write operation (Figure 16). The START condition is followed by the slave address (with the R/W bit set to '0') and the desired byte address. Instead of following-up with data, the master then issues a second START, followed by the 'Current Address Read' sequence, as described in Section 7.10.3.1.

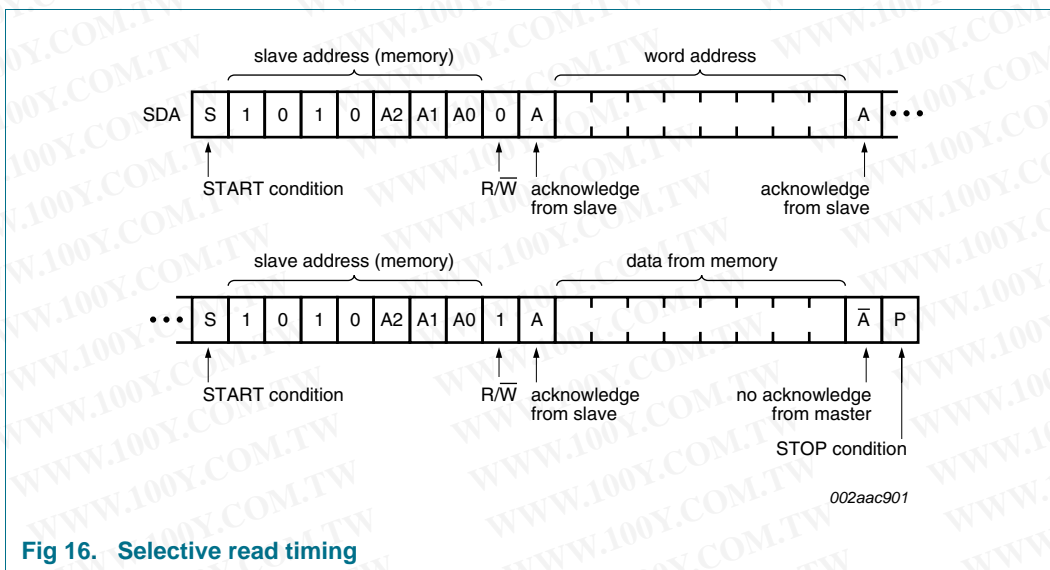

Fig 16. Selective read timing

7.10.3.3 Sequential read

If the master acknowledges the first data byte transmitted by the SE97B, then the device will continue transmitting as long as each data byte is acknowledged by the master (Figure 17). If the end of memory is reached during sequential Read, the address counter will 'wrap around' to the beginning of memory, and so on. Sequential Read works with either 'Immediate Address Read' or 'Selective Read', the only difference being the starting byte address.

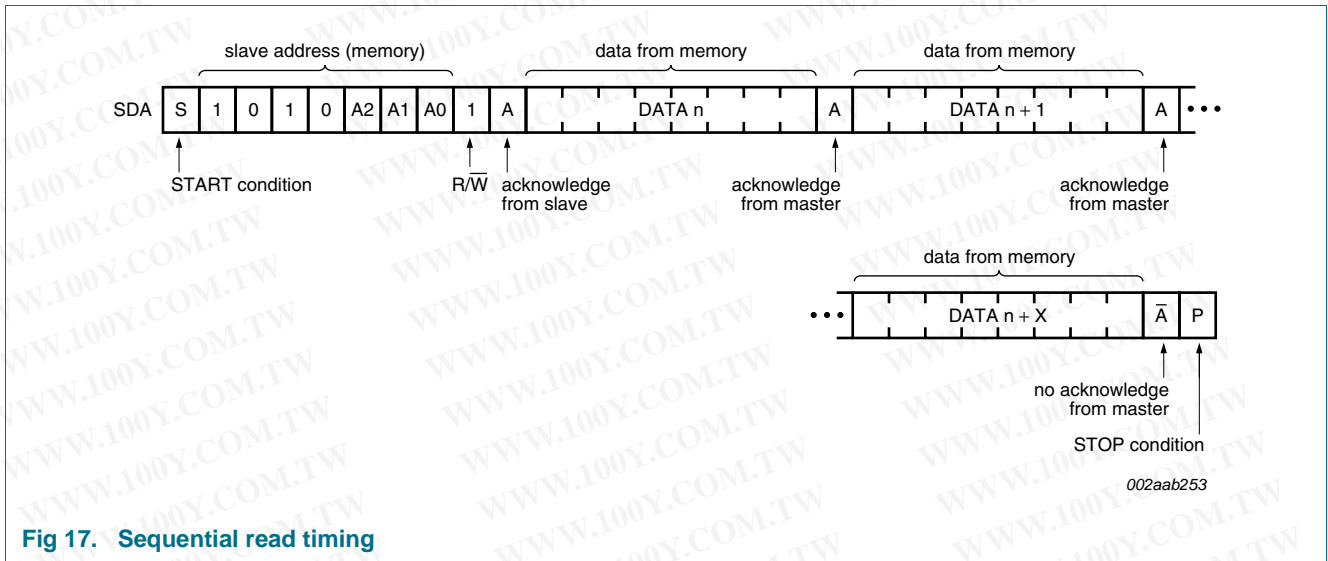

Fig 17. Sequential read timing

勝特力材料 886-3-5753170
 勝特力电子(上海) 86-21-34970699
 勝特力电子(深圳) 86-755-83298787
[Http://www.100y.com.tw](http://www.100y.com.tw)

8. Register descriptions

8.1 Register overview

This section describes all the registers used in the SE97B. The registers are used for latching the temperature reading, storing the low and high temperature limits, configuring, the hysteresis threshold of the ADC, as well as reporting status. The device uses the pointer register to access these registers. Read registers, as the name implies, are used for read only, and the write registers are for write only. Any attempt to read from a write-only register will result in reading '0's. Writing to a read-only register will have no effect on the read even though the write command is acknowledged. The Pointer register is an 8-bit register. All other registers are 16-bit.

Table 9. Register summary

Address (hex)	Default state (hex)	Register name	Short name	JEDEC name
n/a	n/a	Pointer register		
00h	F7h	Capability register	CAP	Capabilities
01h	0000h	Configuration register	CONFIG	Configuration
02h	0000h	Upper Boundary Alarm Trip register	UPPER	High Limit
03h	0000h	Lower Boundary Alarm Trip register	LOWER	Low Limit
04h	0000h	Critical Alarm Trip register	CRITICAL	TCRIT Limit
05h	n/a	Temperature register	TEMP	Ambient Temperature
06h	1131h	Manufacturer ID register	MANID	Manufacturer ID
07h	A203h	Device ID/Revision register	DEVICEID	Device/Revision
08h to 21h	0000h	reserved registers		
22h	21h	SMBus register	SMBUS	
23h to FFh	0000h	reserved		Vendor-defined

A write to reserved registers may cause unexpected results which may result in requiring a reset by removing and re-applying its power.

勝特力材料 886-3-5753170
 勝特力电子(上海) 86-21-34970699
 勝特力电子(深圳) 86-755-83298787
[Http://www.100y.com.tw](http://www.100y.com.tw)

8.2 CAP — Capability register (00h, 16-bit read-only)

Table 10. CAP - Capability register (address 00h) bit allocation

Bit	15	14	13	12	11	10	9	8
Symbol	RFU							
Default	0	0	0	0	0	0	0	0
Access	R	R	R	R	R	R	R	R
Bit	7	6	5	4	3	2	1	0
Symbol	EVSD	TMOUT	VHV	TRES	TRES	WRNG	HACC	BCAP
Default	1	1	1	1	0	1	1	1
Access	R	R	R	R	R	R	R	R

Table 11. Capability register (address 00h) bit description

Bit	Symbol	Description
15:8	RFU	Reserved for future use; must be zero.
7	EVSD	<p>$\overline{\text{EVENT}}$ with shutdown action.</p> <p>0 — The $\overline{\text{EVENT}}$ output freezes in its current state when entering shutdown. Upon exiting shutdown, the $\overline{\text{EVENT}}$ output remains in the previous state until the next thermal sample is taken.</p> <p>1 (default) — The $\overline{\text{EVENT}}$ output is de-asserted (not driven) when entering shutdown, and remains de-asserted upon exit from shutdown until the next thermal sample is taken.</p> <p>Remark: Bit 7 follows the state of SMBUS[4] which can change $\overline{\text{EVENT}}$ output to freeze.</p>
6	TMOUT	<p>Bus time-out period for thermal sensor access during normal operation. Note that bus time-out support is operational in shutdown mode, or for access to the EEPROM portion of the device.</p> <p>1 — Parameter $t_{10}(\text{SMBus})$ is supported within the range of 25 ms to 35 ms (SMBus compatible).</p>
5	VHV	<p>High voltage standoff for pin A0.</p> <p>1 — Supports a voltage up to 10 V on the A0 pin.</p>
4:3	TRES	<p>Temperature resolution.</p> <p>10 — 0.125 °C LSB (11-bit)</p>
2	WRNG	<p>Wider range.</p> <p>1 — can read temperatures below 0 °C and set sign bit accordingly</p>
1	HACC	<p>Higher accuracy (set during manufacture).</p> <p>1 — B grade accuracy</p>
0	BCAP	<p>Basic capability.</p> <p>1 — has Alarm and Critical Trips interrupt capability</p>

勝特力材料 886-3-5753170
 勝特力电子(上海) 86-21-34970699
 勝特力电子(深圳) 86-755-83298787
[Http://www.100y.com.tw](http://www.100y.com.tw)

8.3 CONFIG — Configuration register (01h, 16-bit read/write)

Table 12. CONFIG - Configuration register (address 01h) bit allocation

Bit	15	14	13	12	11	10	9	8
Symbol	RFU			HEN			SHMD	
Default	0	0	0	0	0	0	0	0
Access	R	R	R	R	R	R/W	R/W	R/W
Bit	7	6	5	4	3	2	1	0
Symbol	CTLB	AWLB	CEVNT	ESTAT	EOCTL	CVO	EP	EMD
Default	0	0	0	0	0	0	0	0
Access	R/W	R/W	W	R	R/W	R/W	R/W	R/W

Table 13. Configuration register (address 01h) bit description

Bit	Symbol	Description
15:11	RFU	reserved for future use; must be '0'.
10:9	HEN	Hysteresis Enable. 00 — disable hysteresis (default) 01 — enable hysteresis at 1.5 °C 10 — enable hysteresis at 3 °C 11 — enable hysteresis at 6 °C

When enabled, hysteresis is applied to temperature movement around trigger points. For example, consider the behavior of the 'Above Alarm Window' bit (bit 14 of the Temperature register) when the hysteresis is set to 3 °C. As the temperature rises, bit 14 will be set to '1' (temperature is above the alarm window) when the Temperature register contains a value that is greater than the value in the Alarm Temperature Upper Boundary Register. If the temperature decreases, bit 14 will remain set until the measured temperature is less than or equal to the value in the Alarm Temperature Upper Boundary register minus 3 °C. (Refer to [Figure 4](#) and [Table 14](#)).

Similarly, the 'Below Alarm Window' bit (bit 13 of the Temperature register) will be set to '0' (temperature is equal to or above the Alarm Window Lower Boundary Trip register) when the value in the Temperature register is equal to or greater than the value in the Alarm Temperature Lower Boundary register. As the temperature decreases, bit 13 will be set to '1' when the value in the Temperature register is equal to or less than the value in the Alarm Temperature Lower Boundary register minus 3 °C. Note that hysteresis is also applied to EVENT pin functionality.

When either of the Critical Trip or Alarm Window lock bits is set, these bits cannot be altered until unlocked.

勝特力材料 886-3-5753170
 勝特力电子(上海) 86-21-34970699
 勝特力电子(深圳) 86-755-83298787
[Http://www.100y.com.tw](http://www.100y.com.tw)

Table 13. Configuration register (address 01h) bit description ...continued

Bit	Symbol	Description
8	SHMD	<p>Shutdown Mode.</p> <p>0 — Temperature Sensor is active and converting (default). 1 — disabled Temperature Sensor will not generate interrupts or update the temperature data.</p> <p>When shut down, the thermal sensor diode and ADC are disabled to save power, no events will be generated. When either of the Critical Trip or Alarm Window lock bits is set, this bit cannot be set until unlocked. However, it can be cleared at any time. When in shutdown mode, the SE97B will still respond to commands normally.</p> <p>When coming out of shutdown, the $\overline{\text{EVENT}}$ output remains de-asserted as a new temperature conversion is done. Hysteresis is subtracted from the alarm thresholds if the temperature is falling but not used if the temperature is rising. The temperature trend will not be determined until at least two temperature conversions are done. Since all the alarm threshold flags (TEMP bits 13, 14, 15) are cleared with coming out of shutdown, it was decided to only apply hysteresis to the lower alarm threshold calculations when determining after the initial temperature conversion if the EVENT should assert. After the second temperature conversion the direction of temperature is known and TEMP bits 13, 14 or 15 are changed as required and the $\overline{\text{EVENT}}$ is asserted as required.</p>
7	CTLB	<p>Critical Trip Lock bit.</p> <p>0 — Critical Alarm Trip register is not locked and can be altered (default) 1 — Critical Alarm Trip register settings cannot be altered</p> <p>This bit is initially cleared. When set, this bit will return a '1', and remains locked until cleared by internal Power-on reset. This bit can be written with a single write and does not require double writes.</p>
6	AWLB	<p>Alarm Window Lock bit.</p> <p>0 — Upper and Lower Alarm Trip registers are not locked and can be altered (default) 1 — Upper and Lower Alarm Trip registers setting cannot be altered</p> <p>This bit is initially cleared. When set, this bit will return a '1' and remains locked until cleared by internal power-on reset. This bit can be written with a single write and does not require double writes.</p>
5	CEVNT	<p>Clear $\overline{\text{EVENT}}$ (write only).</p> <p>0 — no effect (default) 1 — clears active $\overline{\text{EVENT}}$ in Interrupt mode. Writing to this register has no effect in Comparator mode.</p> <p>If SMBUS[0] is a logic 0, the SMBus Alert Response Address (ARA) command can be sent to also clear the $\overline{\text{EVENT}}$ output. When read, this register always returns zero.</p>
4	ESTAT	<p>$\overline{\text{EVENT}}$ Status (read only).</p> <p>0 — $\overline{\text{EVENT}}$ output condition is not being asserted by this device (default) 1 — $\overline{\text{EVENT}}$ output pin is being asserted by this device due to Alarm Window or Critical Trip condition</p> <p>The actual event causing the event can be determined from the Read Temperature register. Interrupt Events can be cleared by writing to the 'Clear $\overline{\text{EVENT}}$' bit (CEVNT) or SMBus Alert Response. Writing to this bit will have no effect.</p>

Table 13. Configuration register (address 01h) bit description ...continued

Bit	Symbol	Description
3	EOCTL	<p>$\overline{\text{EVENT}}$ Output Control.</p> <p>0 — $\overline{\text{EVENT}}$ output disabled (default)</p> <p>1 — $\overline{\text{EVENT}}$ output enabled</p> <p>When either of the Critical Trip or Alarm Window lock bits is set, this bit cannot be altered until unlocked.</p>
2	CVO	<p>Critical Event Only.</p> <p>0 — $\overline{\text{EVENT}}$ output on Alarm or Critical temperature event (default)</p> <p>1 — $\overline{\text{EVENT}}$ only if temperature is above the value in the critical temperature register</p> <p>When the alarm window lock bit is set, this bit cannot be altered until unlocked.</p>
1	EP	<p>$\overline{\text{EVENT}}$ Polarity.</p> <p>0 — active LOW (default)</p> <p>1 — active HIGH. When either of the Critical Trip or Alarm Window lock bits is set, this bit cannot be altered until unlocked.</p> <p>When the EP ($\overline{\text{EVENT}}$ Polarity) bit is changed, the $\overline{\text{EVENT}}$ output would immediately change state on the SE97B. A new Shutdown mode has been added on the SE97B with two states defined by the SMBus register EventSleepState = 0. Freeze state of $\overline{\text{EVENT}}$ output and EventSleepState = 1: de-asserted state of $\overline{\text{EVENT}}$ output. So now if the EP bit changes, the $\overline{\text{EVENT}}$ output state will change immediately even during shutdown. It will not wait for the part to do a new temperature conversion after coming out of shutdown. Changes to all other bits in the CONFIG register and the SMBus register take effect after a new temperature conversion happens when the part comes out of shutdown. The EP bit is not related to temperature conversion or readings or if the part is in shutdown or active.</p> <p>Remark: In Shutdown mode, when DisableTimeout = 1 or if DisableTimeout = 0 and Enable SDIO = 0, the $\overline{\text{EVENT}}$ Polarity bit will not take effect immediately, but will updated after it comes out of shutdown.</p>
0	EMD	<p>$\overline{\text{EVENT}}$ Mode.</p> <p>0 — comparator output mode (default)</p> <p>1 — interrupt mode</p> <p>When either of the Critical Trip or Alarm Window lock bits is set, this bit cannot be altered until unlocked.</p>

勝特力材料 886-3-5753170
 勝特力电子(上海) 86-21-34970699
 勝特力电子(深圳) 86-755-83298787
[Http://www.100y.com.tw](http://www.100y.com.tw)

Table 14. Hysteresis Enable

Action	Below Alarm Window bit (bit 13)		Above Alarm Window bit (bit 14)		Above Critical Trip bit (bit 15)	
	Temperature slope	Threshold temperature	Temperature slope	Threshold temperature	Temperature slope	Threshold temperature
sets	falling	$T_{trip(l)} - T_{hys}$	rising	$T_{trip(u)}$	rising	$T_{th(crit)}$
clears	rising	$T_{trip(l)}$	falling	$T_{trip(u)} - T_{hys}$	falling	$T_{th(crit)} - T_{hys}$

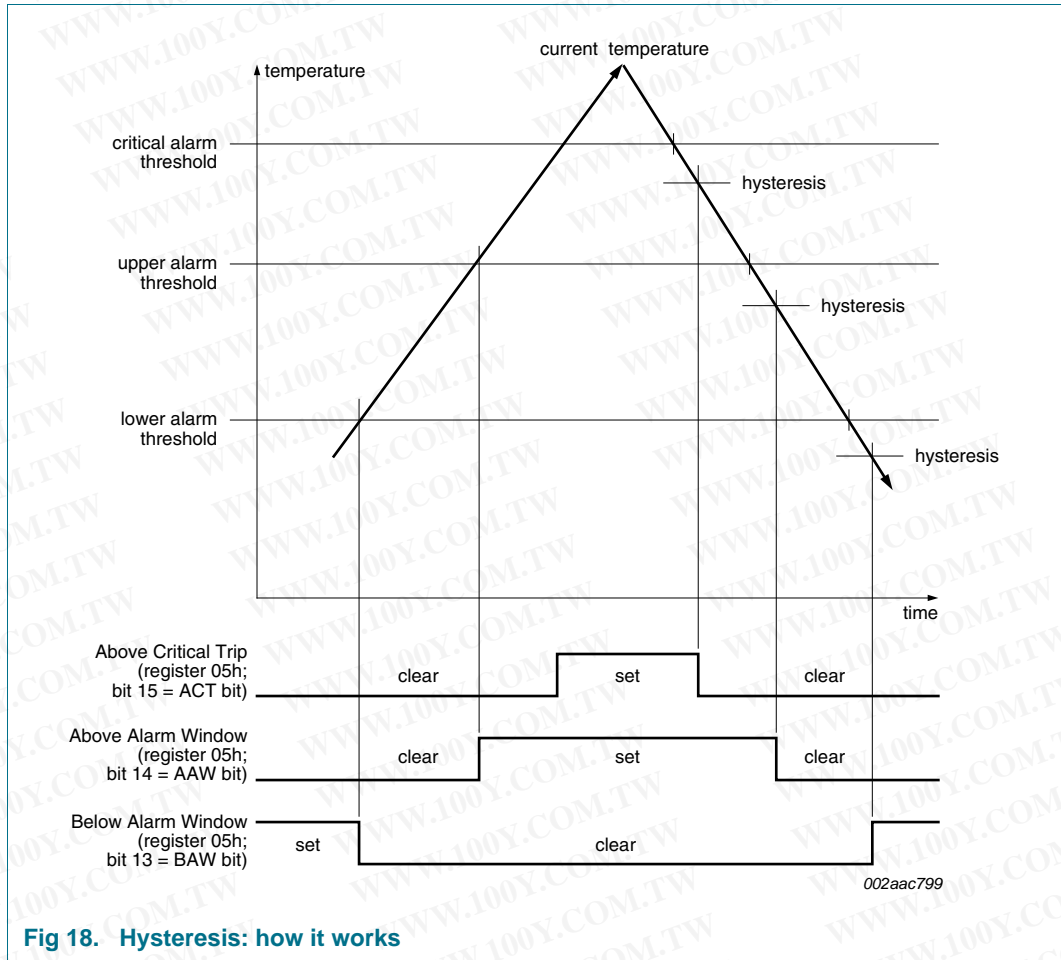

Fig 18. Hysteresis: how it works

勝特力材料 886-3-5753170
 勝特力电子(上海) 86-21-34970699
 勝特力电子(深圳) 86-755-83298787
[Http://www.100y.com.tw](http://www.100y.com.tw)

8.4 Temperature format

The temperature data from the temperature read back register is an 11-bit 2's complement word with the least significant bit (LSB) equal to 0.125 °C (resolution).

- A value of 019Ch will represent 25.75 °C
- A value of 07C0h will represent 124 °C
- A value of 1E64h will represent -25.75 °C.

The unused LSB (bit 0) is set to '0'. Bit 11 will have a resolution of 128 °C.

The upper 3 bits of the temperature register indicate Trip Status based on the current temperature, and are not affected by the status of the EVENT output.

One of the ways to calculate the Temperature, Upper Boundary, Lower Boundary, and Critical Alarm Trip values in °C from the 12-bit Temp data is:

- If the SIGN bit = 0, then the temperature is positive,
(°C) = +(Temp data) × 0.125 °C (0.250 °C for alarm registers).
- If the SIGN bit = 1, then the temperature is negative,
(°C) = -(2's complement of Temp data) × 0.125 °C (0.250 °C for alarm registers).

Table 15 lists the examples of the content of the temperature data register for positive and negative temperature for two scenarios of status bits: status bits = 000b and status bits = 111b.

Table 15. Degree Celsius and Temperature Data register

Temperature	Content of Temperature Data register			
	Status bits = 000b		Status bits = 111b	
	Binary	Hex	Binary	Hex
+125 °C	000 0 01111101 000 0	07D0h	111 0 01111101 000 0	E7D0h
+25 °C	000 0 00011001 000 0	0190h	111 0 00011001 000 0	E190h
+1 °C	000 0 00000001 000 0	0010h	111 0 00000001 000 0	E010h
+0.25 °C	000 0 00000000 010 0	0004h	111 0 00000000 010 0	E004h
+0.125 °C	000 0 00000000 001 0	0002h	111 0 00000000 001 0	E002h
0 °C	000 0 00000000 000 0	0000h	111 0 00000000 000 0	E000h
-0.125 °C	000 1 11111111 111 0	1FFEh	111 1 11111111 111 0	FFFEh
-0.25 °C	000 1 11111111 110 0	1FFCh	111 1 11111111 110 0	FFCh
-1 °C	000 1 11111111 000 0	1FF0h	111 1 11111111 000 0	FFF0h
-20 °C	000 1 11110100 000 0	1F40h	111 1 11110100 000 0	FF40h
-25 °C	000 1 11100111 000 0	1E70h	111 1 11100111 000 0	FE70h
-55 °C	000 1 11001001 000 0	1C90h	111 1 11001001 000 0	FC90h

勝特力材料 886-3-5753170
 勝特力电子(上海) 86-21-34970699
 勝特力电子(深圳) 86-755-83298787
[Http://www.100y.com.tw](http://www.100y.com.tw)

8.5 Temperature Trip Point registers

While writing to the 16-bit Upper, Lower, or Critical Boundary Alarm Trip registers, please ensure that both bytes get written before doing a new START or STOP to ensure that a valid temperature value gets written into the registers.

8.5.1 UPPER — Upper Boundary Alarm Trip register (02h, 16-bit read/write)

The value is the upper threshold temperature value for Alarm mode. The data format is 2’s complement with bit 2 = 0.25 °C. ‘RFU’ bits will always report zero. Interrupts will respond to the presently programmed boundary values. If boundary values are being altered in-system, it is advised to turn off interrupts until a known state can be obtained to avoid superfluous interrupt activity.

Table 16. UPPER - Upper Boundary Alarm Trip register bit allocation

Bit	15	14	13	12	11	10	9	8
Symbol	RFU	RFU	RFU	SIGN	128 °C	64 °C	32 °C	16 °C
Default	0	0	0	0	0	0	0	0
Access	R	R	R	R/W	R/W	R/W	R/W	R/W
Bit	7	6	5	4	3	2	1	0
Symbol	8 °C	4 °C	2 °C	1 °C	0.5 °C	0.25 °C	RFU	RFU
Default	0	0	0	0	0	0	0	0
Access	R/W	R/W	R/W	R/W	R/W	R/W	R	R

Table 17. Upper Boundary Alarm Trip register bit description

Bit	Symbol	Description
15:13	RFU	reserved; always ‘0’
12	SIGN	Sign (MSB)
11:2	-	Upper Boundary Alarm Trip Temperature (LSB = 0.25 °C)
1:0	RFU	reserved; always ‘0’

勝特力材料 886-3-5753170
 勝特力电子(上海) 86-21-34970699
 勝特力电子(深圳) 86-755-83298787
[Http://www.100y.com.tw](http://www.100y.com.tw)

8.5.2 LOWER — Lower Boundary Alarm Trip register (03h, 16-bit read/write)

The value is the lower threshold temperature value for Alarm mode. The data format is 2's complement with bit 2 = 0.25 °C. RFU bits will always report zero. Interrupts will respond to the presently programmed boundary values. If boundary values are being altered in-system, it is advised to turn off interrupts until a known state can be obtained to avoid superfluous interrupt activity.

Table 18. LOWER - Lower Boundary Alarm Trip register bit allocation

Bit	15	14	13	12	11	10	9	8
Symbol	RFU	RFU	RFU	SIGN	128 °C	64 °C	32 °C	16 °C
Default	0	0	0	0	0	0	0	0
Access	R	R	R	R/W	R/W	R/W	R/W	R/W
Bit	7	6	5	4	3	2	1	0
Symbol	8 °C	4 °C	2 °C	1 °C	0.5 °C	0.25 °C	RFU	RFU
Default	0	0	0	0	0	0	0	0
Access	R/W	R/W	R/W	R/W	R/W	R/W	R	R

Table 19. Lower Boundary Alarm Trip register bit description

Bit	Symbol	Description
15:13	RFU	reserved; always '0'
12	SIGN	Sign (MSB)
11:2	-	Lower Boundary Alarm Trip Temperature (LSB = 0.25 °C)
1:0	RFU	reserved; always '0'

8.5.3 CRITICAL — Critical Alarm Trip register (04h, 16-bit read/write)

The value is the critical temperature. The data format is 2's complement with bit 2 = 0.25 °C. RFU bits will always report zero.

Table 20. CRITICAL - Critical Alarm Trip register bit allocation

Bit	15	14	13	12	11	10	9	8
Symbol	RFU	RFU	RFU	SIGN	128 °C	64 °C	32 °C	16 °C
Default	0	0	0	0	0	0	0	0
Access	R	R	R	R/W	R/W	R/W	R/W	R/W
Bit	7	6	5	4	3	2	1	0
Symbol	8 °C	4 °C	2 °C	1 °C	0.5 °C	0.25 °C	RFU	RFU
Default	0	0	0	0	0	0	0	0
Access	R/W	R/W	R/W	R/W	R/W	R/W	R	R

Table 21. Critical Alarm Trip register bit description

Bit	Symbol	Description
15:13	RFU	reserved; always '0'
12	SIGN	Sign (MSB)
11:2	-	Critical Alarm Trip Temperature (LSB = 0.25 °C)
1:0	RFU	reserved; always '0'

8.6 TEMP — Temperature register (05h, 16-bit read-only)

Table 22. TEMP - Temperature register bit allocation

Bit	15	14	13	12	11	10	9	8
Symbol	ACT	AAW	BAW	SIGN	128 °C	64 °C	32 °C	16 °C
Default	0	0	0	0	0	0	0	0
Access	R	R	R	R	R	R	R	R
Bit	7	6	5	4	3	2	1	0
Symbol	8 °C	4 °C	2 °C	1 °C	0.5 °C	0.25 °C	0.125 °C	RFU
Default	0	0	0	0	0	0	0	0
Access	R	R	R	R	R	R	R	R

Table 23. Temperature register bit description

Bit	Symbol	Description
15	ACT	Above Critical Trip. Increasing T_{amb} : 0 — $T_{amb} < T_{th(crit)}$ 1 — $T_{amb} \geq T_{th(crit)}$ Decreasing T_{amb} : 0 — $T_{amb} < T_{th(crit)} - T_{hys}$ 1 — $T_{amb} \geq T_{th(crit)} - T_{hys}$
14	AAW	Above Alarm Window. Increasing T_{amb} : 0 — $T_{amb} \leq T_{trip(u)}$ 1 — $T_{amb} > T_{trip(u)}$ Decreasing T_{amb} : 0 — $T_{amb} \leq T_{trip(u)} - T_{hys}$ 1 — $T_{amb} > T_{trip(u)} - T_{hys}$
13	BAW	Below Alarm Window. Increasing T_{amb} : 0 — $T_{amb} \geq T_{trip(l)}$ 1 — $T_{amb} < T_{trip(l)}$ Decreasing T_{amb} : 0 — $T_{amb} \geq T_{trip(l)} - T_{hys}$ 1 — $T_{amb} < T_{trip(l)} - T_{hys}$
12	SIGN	Sign bit. 0 — positive temperature value 1 — negative temperature value
11:1	-	Temperature Value (2's complement). (LSB = 0.125 °C)
0	RFU	reserved; always '0'

勝特力材料 886-3-5753170
 勝特力电子(上海) 86-21-34970699
 勝特力电子(深圳) 86-755-83298787
[Http://www.100y.com.tw](http://www.100y.com.tw)

8.7 MANID — Manufacturer’s ID register (06h, 16-bit read-only)

The SE97B Manufacturer’s ID register is intended to match NXP Semiconductors PCI SIG (1131h).

Table 24. MANID - Manufacturer’s ID register bit allocation

Bit	15	14	13	12	11	10	9	8
Symbol	Manufacturer ID							
Default	0	0	0	1	0	0	0	1
Access	R	R	R	R	R	R	R	R
Bit	7	6	5	4	3	2	1	0
Symbol	(cont.)							
Default	0	0	1	1	0	0	0	1
Access	R	R	R	R	R	R	R	R

8.8 DEVICEID — Device ID register (07h, 16-bit read-only)

The SE97B device ID is A2h. The device revision is 03h.

Table 25. DEVICEID - Device ID register bit allocation for SE97B

Bit	15	14	13	12	11	10	9	8
Symbol	Device ID							
Default	1	0	1	0	0	0	1	0
Access	R	R	R	R	R	R	R	R
Bit	7	6	5	4	3	2	1	0
Symbol	Device revision							
Default	0	0	0	0	0	0	1	1
Access	R	R	R	R	R	R	R	R

勝特力材料 886-3-5753170
 勝特力电子(上海) 86-21-34970699
 勝特力电子(深圳) 86-755-83298787
[Http://www.100y.com.tw](http://www.100y.com.tw)

8.9 SMBUS — SMBus register (22h, 8-bit read/write)

Table 26. SMBUS - SMBus Time-out register bit allocation

Bit	15	14	13	12	11	10	9	8
Symbol	RFU							
Default	0	0	0	0	0	0	0	0
Access	R	R	R	R	R	R	R	R
Bit	7	6	5	4	3	2	1	0
Symbol	Disable Timeout	RFU	Enable SDTO	Event Sleep State	IntrClear Mode	Flag Update Mode	RFU	Disable ARA
Default	0	0	1	1	0	0	0	1
Access	R/W	R	R/W	R/W	R/W	R/W	R	R/W

Table 27. SMBus Time-out register bit description

Bit	Symbol	Description
15:8	RFU	reserved; always '0'
7	DisableTimeout	Disable SMBus time-out. 0 — SMBus time-out is enabled (default) 1 — SMBus time-out is disabled When either of the Critical Trip or Alarm Window lock bits is set, this bit cannot be altered until unlocked.
6	RFU	reserved; always '0'
5	EnableSDTO	SMBus time-out during Shutdown (CONFIG[8]). 0 — disable SMBus time-out 1 — enable SMBus time-out (default) Remark: DisableTimeout bit must be a logic 0 to enable this feature. When either Critical Trip or Alarm Window lock bits are set, this bit cannot be altered until unlocked.
4	EventSleep State ^[1]	State of $\overline{\text{EVENT}}$ output when SHMD bit is set. 0 — $\overline{\text{EVENT}}$ pin state is frozen 1 — $\overline{\text{EVENT}}$ pin is de-asserted, state based on Polarity bit (default) When either Critical Trip or Alarm Window lock bits are set, this bit cannot be altered until unlocked.
3	IntrClear Mode ^[2]	Interrupt Flop Clearing Mode. 0 — allow clearing interrupt flop while in comparator mode (default) 1 — disable clearing interrupt flow while in comparator mode When either Critical Trip or Alarm Window lock bits are set, this bit cannot be altered until unlocked.
2	FlagUpdate Mode	Update AAW, BAW and ACT flags after each new temperature conversion. 0 — update AAW, BAW and ACT flags continuously (default) 1 — update flags with new temperature conversion When either Critical Trip or Alarm Window lock bits are set, this bit cannot be altered until unlocked.

Table 27. SMBus Time-out register bit description ...continued

Bit	Symbol	Description
1	RFU	reserved; always '0'
0	DisableARA	Disable SMBus Alert Response Address (ARA). 0 — SMBus ARA is enabled 1 — disable SMBus ARA (default) When either of the Critical Trip or Alarm Window lock bits is set, this bit cannot be altered until unlocked.

- [1] When the part comes out of shutdown, the state of the $\overline{\text{EVENT}}$ pin will not change until after the first temperature conversion. When the part enters shutdown, the ACT (TEMP[15]), AAW (TEMP[14]) and BAW (TEMP[13]) bits (flip-flops) will be cleared.
- [2] The STTS424E02 allows clearing the interrupt when in comparator mode, but the other competitors do not.

Table 28. SMBus register setting guide

Disable Timeout ^[1]	Enable SDTO ^[2]	SHMD ^[3]	Thermal sensor behavior	SPD behavior	Power mode	Use
0	X	0	TS is active and SMBus TO is on	SPD read/write and SMBus TO is on	Full power, oscillator is running	JEDEC - SMBus for TS and SPD (like SE97 if TS is on)
1	X	0	TS is active and SMBus TO is off	SPD read/write and SMBus TO is off	Full power, oscillator is running	I ² C-bus - no SMBus TO
0	1	1	TS is disabled and SMBus TO is on	SPD read/write and SMBus TO is on	Lower power, oscillator is off unless bus active or write to SPD	JEDEC - SMBus for TS and SPD
1	1	1	TS is disabled and SMBus TO is off	SPD low power read/write and SMBus TO is off	Lower power, oscillator is off unless write to the SPD	I ² C-bus - no SMBus TO
X	0	1	TS is disabled and SMBus TO is off	SPD low power read-only and SMBus TO is off	Lowest power, oscillator is off all the time	I ² C-bus - no SMBus TO (like SE97 if TS is off)

- [1] SMBus Time-out.
0 — enabled (default)
1 — disabled
- [2] Shutdown time-out.
0 — SMBus Time-out disabled when SHMD = 1
1 — SMBus Time-out enabled when SHMD = 1 (default)
- [3] Thermal Sensor Shutdown mode.
0 — active (default)
1 — shutdown

勝特力材料 886-3-5753170
 勝特力电子(上海) 86-21-34970699
 勝特力电子(深圳) 86-755-83298787
[Http://www.100y.com.tw](http://www.100y.com.tw)

9. Application design-in information

In a typical application, the SE97B behaves as a slave device and interfaces to a bus master (or host) via the SCL and SDA lines. The $\overline{\text{EVENT}}$ output is monitored by the host, and asserts when the temperature reading exceeds the programmed values in the alarm registers. The A0, A1 and A2 pins are directly connected to V_{DD} or V_{SS} without any pull-up resistors. The SDA and SCL serial interface pins are open-drain I/Os that require pull-up resistors, and are able to sink a maximum of 3 mA with a voltage drop less than 0.4 V. Typical pull-up values for SCL and SDA are 10 k Ω , but the resistor values can be changed in order to meet the rise time requirement if the capacitance load is too large due to routing, connectors, or multiple components sharing the same bus.

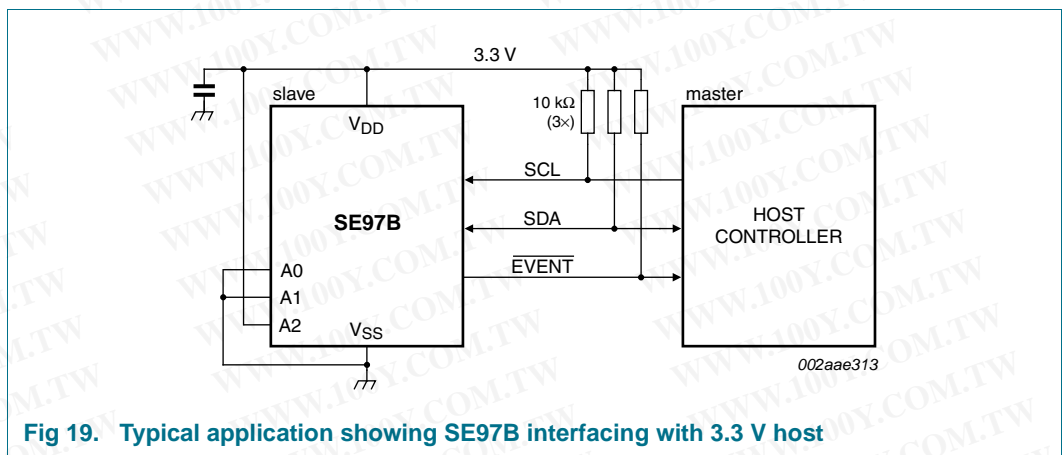

Fig 19. Typical application showing SE97B interfacing with 3.3 V host

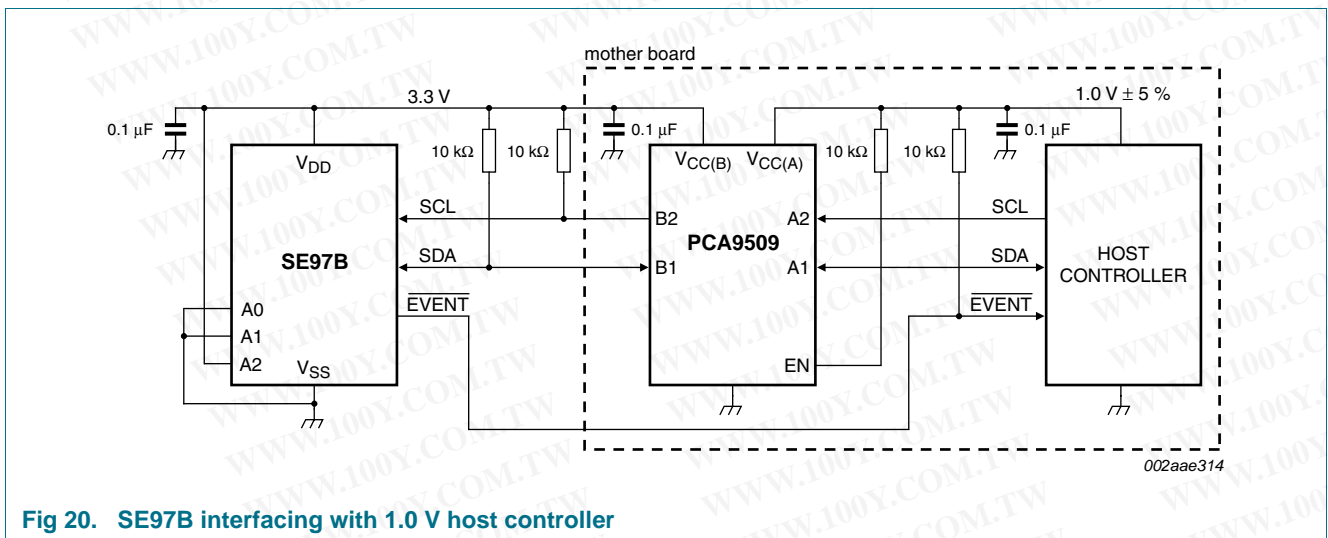

Fig 20. SE97B interfacing with 1.0 V host controller

勝特力材料 886-3-5753170
 勝特力电子(上海) 86-21-34970699
 勝特力电子(深圳) 86-755-83298787
[Http://www.100y.com.tw](http://www.100y.com.tw)

9.1 SE97B in memory module application

Figure 21 shows the SE97B being placed in the memory module application. The SE97B is centered in the memory module to monitor the temperature of the DRAM and also to provide a 2-kbit EEPROM as the Serial Presence Detect (SPD). In the event of overheating, the SE97B triggers the EVENT output and the memory controller throttles the memory bus to slow the DRAM. The memory controller can also read the SE97B and watch the DRAM thermal behavior, taking preventive measures when necessary.

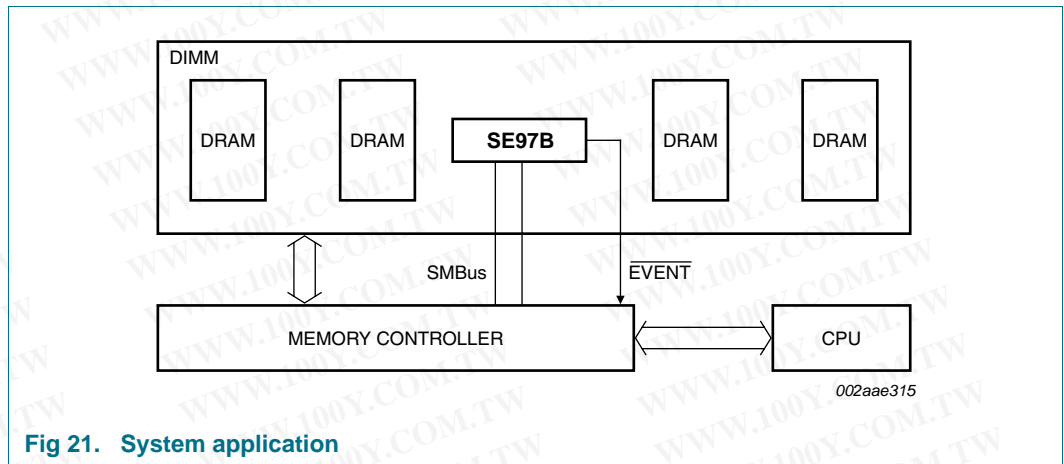

Fig 21. System application

9.2 Layout consideration

The SE97B does not require any additional components other than the host controller to read its temperature. It is recommended that a 0.1 μF bypass capacitor between the V_{DD} and V_{SS} pins is located as close as possible to the power and ground pins for noise protection.

9.3 Thermal considerations

In general, self-heating is the result of power consumption and not a concern, especially with the SE97B, which consumes very low power. In the event the SDA and EVENT pins are heavily loaded with small pull-up resistor values, self-heating affects temperature accuracy by approximately 0.5 °C.

Equation 1 is the formula to calculate the effect of self-heating:

$$\Delta T = R_{th(j-a)} \times [(V_{DD} \times I_{DD(AV)}) + (V_{OL(SDA)} \times I_{OL(sink)(SDA)}) + (V_{OL(EVENT)} \times I_{OL(sink)EVENT})] \quad (1)$$

where:

$$\Delta T = T_j - T_{amb}$$

T_j = junction temperature

T_{amb} = ambient temperature

R_{th(j-a)} = package thermal resistance

V_{DD} = supply voltage

I_{DD(AV)} = average supply current

勝特力材料 886-3-5753170
 勝特力电子(上海) 86-21-34970699
 勝特力电子(深圳) 86-755-83298787
[Http://www.100y.com.tw](http://www.100y.com.tw)

$V_{OL(SDA)}$ = LOW-level output voltage on pin SDA

$V_{OL(EVENT)}$ = LOW-level output voltage on pin \overline{EVENT}

$I_{OL(sink)(SDA)}$ = SDA output current LOW

$I_{OL(sink)EVENT}$ = \overline{EVENT} output current LOW

Calculation example:

T_{amb} (typical temperature inside the notebook) = 50 °C

$I_{DD(AV)}$ = 400 μ A

V_{DD} = 3.6 V

Maximum $V_{OL(SDA)}$ = 0.4 V

$I_{OL(sink)(SDA)}$ = 1 mA

$V_{OL(EVENT)}$ = 0.4 V

$I_{OL(sink)EVENT}$ = 3 mA

$R_{th(j-a)}$ = 56 °C/W

Self heating due to power dissipation is:

$$\Delta T = 56 \times [(3.6 \times 0.4) + (0.4 \times 3) + (0.4 \times 1)] = 56 \text{ } ^\circ\text{C/W} \times 3.04 \text{ mW} = 0.17 \text{ } ^\circ\text{C} \quad (2)$$

9.4 Hot plugging

The SE97B can be used in hot plugging applications. Internal circuitry prevents damaging current backflow through the device when it is powered down, but with the I²C-bus, \overline{EVENT} or address pins still connected. The open-drain SDA and \overline{EVENT} pins (SCL and address pins are input only) effectively places the outputs in a high-impedance state during power-up and power-down, which prevents driver conflict and bus contention. The 50 ns noise filter will filter out any insertion glitches from the state machine, which is very robust and not prone to false operation.

The device needs a proper power-up sequence to reset itself, not only for the device I²C-bus and I/O initial states, but also to load specific pre-defined data or calibration data into its operational registers. The power-up sequence should occur correctly with a fast ramp rate and the I²C-bus active. The SE97B might not respond immediately after power-up, but it should not damage the part if the power-up sequence is abnormal. If the SCL line is held LOW, the part will not exit the power-on reset mode since the part is held in reset until SCL is released.

勝特力材料 886-3-5753170
 勝特力电子(上海) 86-21-34970699
 勝特力电子(深圳) 86-755-83298787
[Http://www.100y.com.tw](http://www.100y.com.tw)

10. Limiting values

Table 29. Limiting values

In accordance with the Absolute Maximum Rating System (IEC 60134).

Symbol	Parameter	Conditions	Min	Max	Unit
V_{DD}	supply voltage		-0.5	+4.3	V
V_n	voltage on any other pin	SDA, SCL, A1, A2, EVENT pins	-0.5	+4.3	V
V_{A0}	voltage on pin A0	overvoltage input; A0 pin	-0.5	+12.5	V
I_{sink}	sink current	SDA, EVENT pins	-1	+10	mA
$T_{j(max)}$	maximum junction temperature		-	150	°C
T_{stg}	storage temperature		-65	+165	°C

11. Characteristics

Table 30. Thermal sensor characteristics

$V_{DD} = 3.0\text{ V to }3.6\text{ V}$; $T_{amb} = -40\text{ °C to }+125\text{ °C}$; unless otherwise specified.

Symbol	Parameter	Conditions	Min	Typ	Max	Unit
$T_{lim(acc)}$	temperature limit accuracy	B-grade; $V_{DD} = 3.0\text{ V to }3.6\text{ V}$				
		$T_{amb} = 75\text{ °C to }95\text{ °C}$	-1.0	< ±0.5	+1.0	°C
		$T_{amb} = 40\text{ °C to }125\text{ °C}$	-2.0	< ±1.0	+2.0	°C
		$T_{amb} = -40\text{ °C to }+125\text{ °C}$	-3.0	< ±2	+3.0	°C
T_{res}	temperature resolution		-	0.125	-	°C
T_{conv}	conversion period		-	100	120	ms
$E_f(conv)$	conversion rate error	percentage error in programmed data	-30	-	30	%

勝特力材料 886-3-5753170
 勝特力电子(上海) 86-21-34970699
 勝特力电子(深圳) 86-755-83298787
[Http://www.100y.com.tw](http://www.100y.com.tw)

Table 31. DC characteristics

$V_{DD} = 3.0\text{ V to }3.6\text{ V}$; $T_{amb} = -40\text{ }^{\circ}\text{C to }+125\text{ }^{\circ}\text{C}$; unless otherwise specified. These specifications are guaranteed by design.

Symbol	Parameter	Conditions	Min	Typ	Max	Unit
V_{DD}	supply voltage		3.0	-	3.6	V
$I_{DD(AV)}$	average supply current	SMBus inactive	[1] -	210	320	μA
I_{DD}	supply current	$f_{SCL} = 400\text{ kHz}$	-	250	400	μA
$I_{sd(VDD)}$	supply voltage shutdown mode current	SMBus inactive	-	0.1	10	μA
V_{IH}	HIGH-level input voltage	SCL, SDA	$0.7 \times V_{DD}$	-	$V_{DD} + 1$	V
V_{IL}	LOW-level input voltage	SCL, SDA	-0.5	-	$+0.3 \times V_{DD}$	V
$V_{I(ov)}$	overvoltage input voltage	pin A0; $V_{I(ov)} - V_{DD} > 4.8\text{ V}$	[2] 7.0	-	10	V
V_{OL}	LOW-level output voltage	SDA, $\overline{\text{EVENT}}$				
		$I_{OL} = 0.7\text{ mA}$	-	-	0.2	V
		$I_{OL} = 2.1\text{ mA}$	-	-	0.4	V
		$I_{OL} = 3.0\text{ mA}$	-	-	0.5	V
$V_{I(hys)}$	hysteresis of input voltage	$V_{DD} \geq 2.2\text{ V}$	$0.05 \times V_{DD}$	-	-	V
		$V_{DD} \leq 2.2\text{ V}$	$0.10 \times V_{DD}$	-	-	V
$V_{th(POR)H}$	HIGH-level power-on reset threshold voltage	device operation voltage increase	-	-	2.9	V
$V_{th(rec)POR}$	power-on reset recovery threshold voltage	device reset voltage decrease	1.2	1.8	-	V
I_{LOH}	HIGH-level output leakage current	$\overline{\text{EVENT}}$; $V_{OH} = V_{DD}$	-1.0	-	+1.0	μA
I_{LIH}	HIGH-level input leakage current	SDA, SCL; $V_I = V_{DD}$	-1.0	-	+1.0	μA
I_{LIL}	LOW-level input leakage current	SDA, SCL; $V_I = V_{SS}$	-1.0	-	+1.0	μA
		A0, A1, A2; $V_I = V_{SS}$	-1.0	-	+1.0	μA
$C_{i(SCL/SDA)}$	SCL and SDA input capacitance		-	5	8	pF
$C_{i(addr)}$	address input capacitance		-	5	10	pF
I_{pd}	pull-down current	internal; A0, A1, A2 pins; $V_I = 0.3V_{DD}$ to V_{DD}	-	-	4.0	μA
Z_{IL}	LOW-level input impedance	pins A0, A1, A2; $V_I < 0.3V_{DD}$	30	-	-	k Ω
Z_{IH}	HIGH-level input impedance	pins A0, A1, A2; $V_I \geq 0.3V_{DD}$	800	-	-	k Ω

[1] If the temperature sensor is not needed it should be placed in standby, which will reduce $I_{DD(AV)}$ to 0.1 μA typical at room temperature or 3.0 μA typical at 125 $^{\circ}\text{C}$.

[2] High-voltage input voltage applied to pin A0 during RWP and CRWP operations. The JEDEC specification is 7 V (min.) and 10 V (max.). When V_{DD} is 3.6 V, then $I_{I(ov)} > 4.8\text{ V} + V_{DD}$ or $> 4.8\text{ V} + 3.6\text{ V}$ then the minimum voltage is 8.4 V.

勝特力材料 886-3-5753170
 勝特力电子(上海) 86-21-34970699
 勝特力电子(深圳) 86-755-83298787
[Http://www.100y.com.tw](http://www.100y.com.tw)

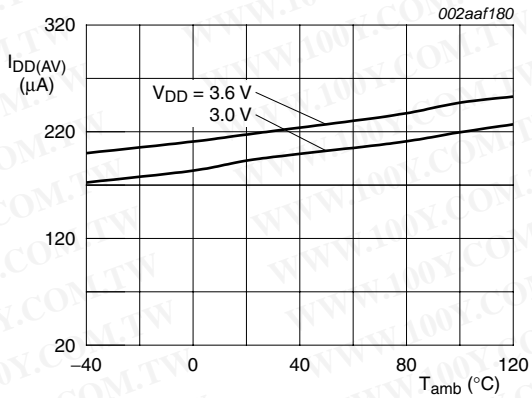

I²C-bus inactive.

Fig 22. Average supply current

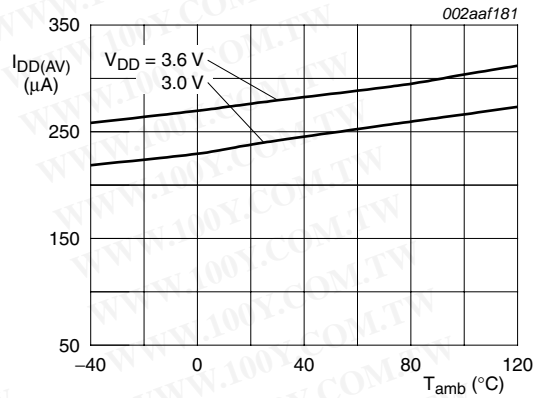

f_{SCL} = 400 kHz.

Fig 23. Average supply current

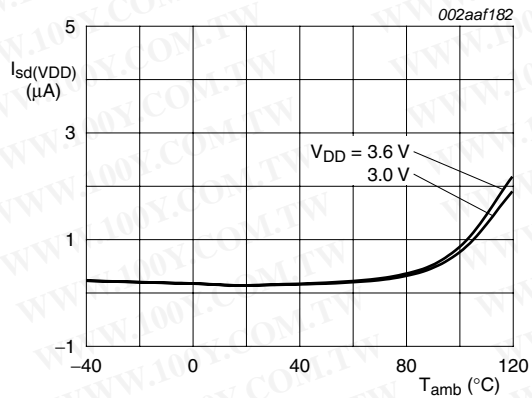

Fig 24. Shutdown supply current

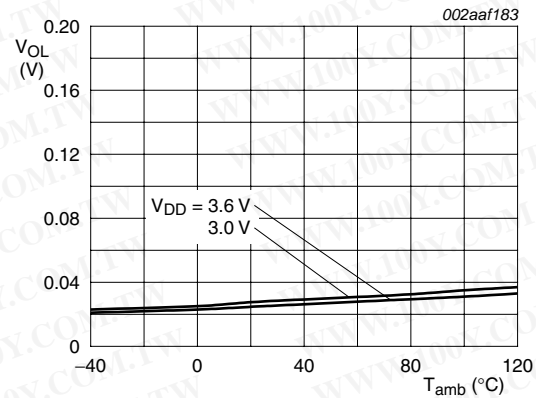

Fig 25. SDA output V_{OL} at I_{OL} = 0.7 mA

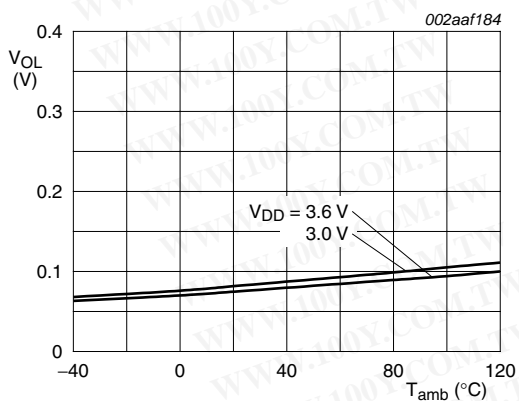

Fig 26. SDA output V_{OL} at I_{OL} = 2.1 mA

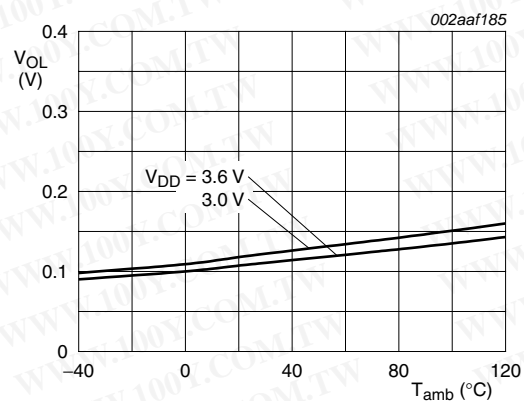

Fig 27. SDA output V_{OL} at I_{OL} = 3.0 mA

勝特力材料 886-3-5753170
 勝特力电子(上海) 86-21-34970699
 勝特力电子(深圳) 86-755-83298787
[Http://www.100y.com.tw](http://www.100y.com.tw)

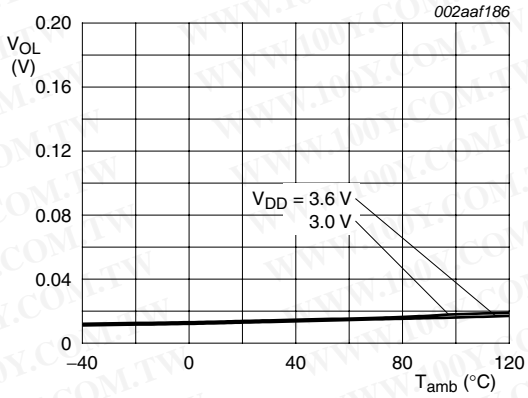

Fig 28. $\overline{\text{EVENT}}$ output V_{OL} at $I_{OL} = 0.7 \text{ mA}$

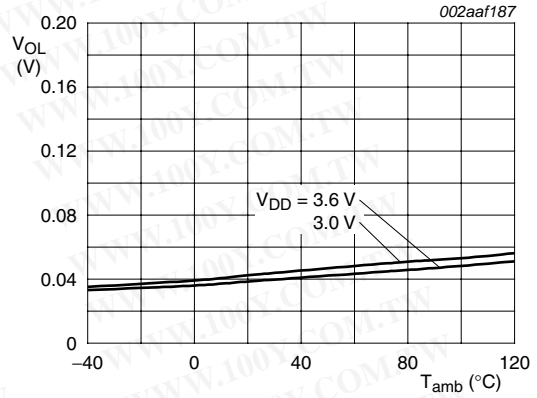

Fig 29. $\overline{\text{EVENT}}$ output V_{OL} at $I_{OL} = 2.1 \text{ mA}$

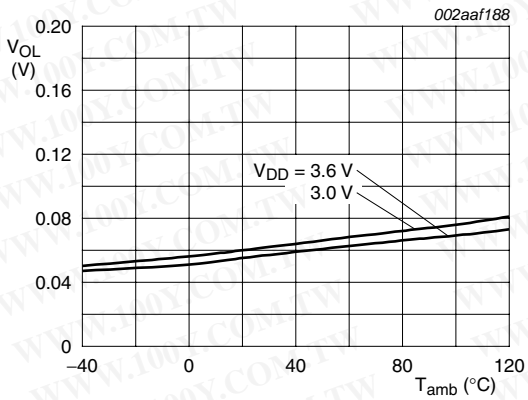

Fig 30. $\overline{\text{EVENT}}$ output V_{OL} at $I_{OL} = 3.0 \text{ mA}$

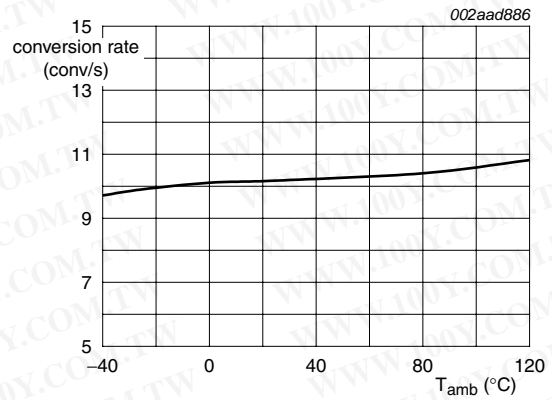

Fig 31. Conversion rate

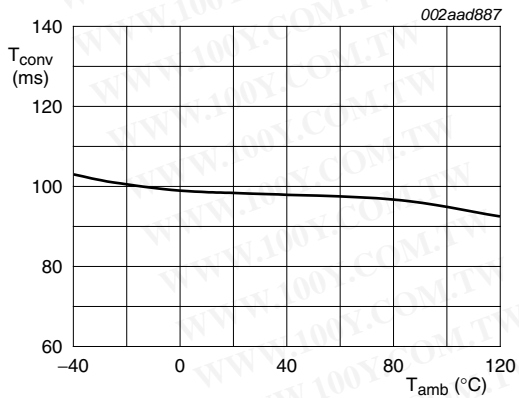

Fig 32. Conversion period

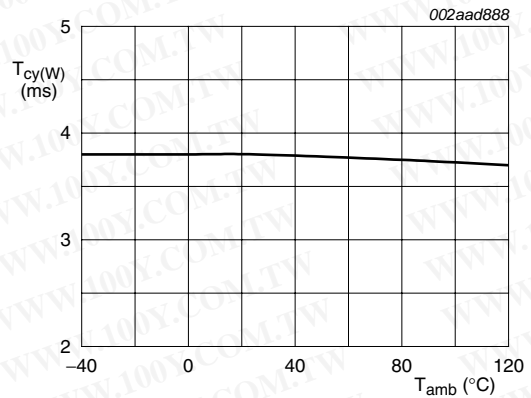
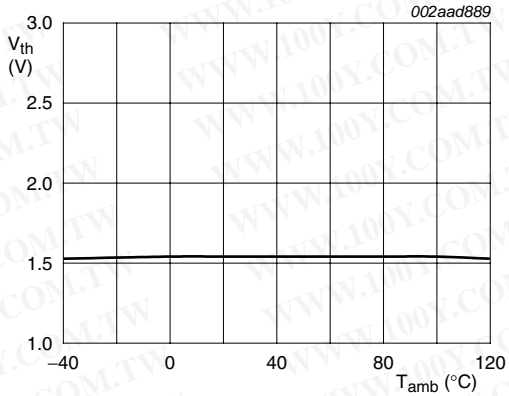

Fig 33. EEPROM write cycle time

勝特力材料 886-3-5753170
 勝特力电子(上海) 86-21-34970699
 勝特力电子(深圳) 86-755-83298787
[Http://www.100y.com.tw](http://www.100y.com.tw)



For temp sensor conversion.

Fig 34. Average power-on threshold voltage

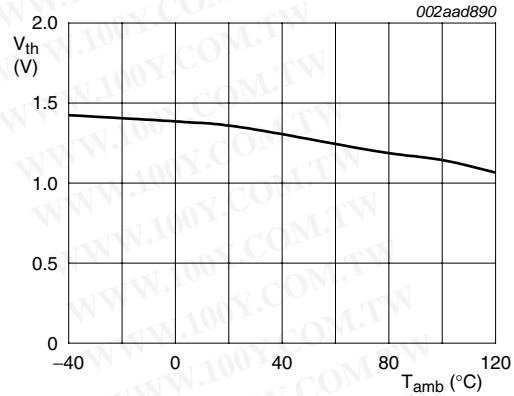

For EEPROM read operation.

Fig 35. Average power-on threshold voltage

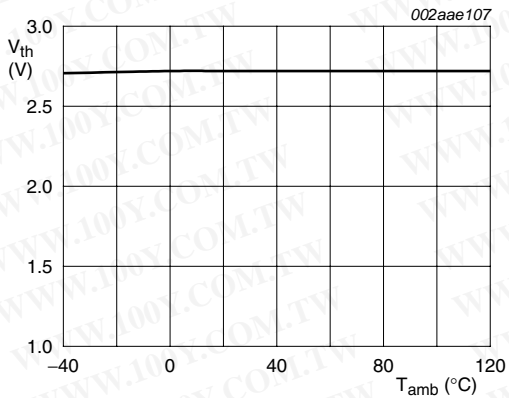

For EEPROM write operation.

Fig 36. Average power-on threshold voltage

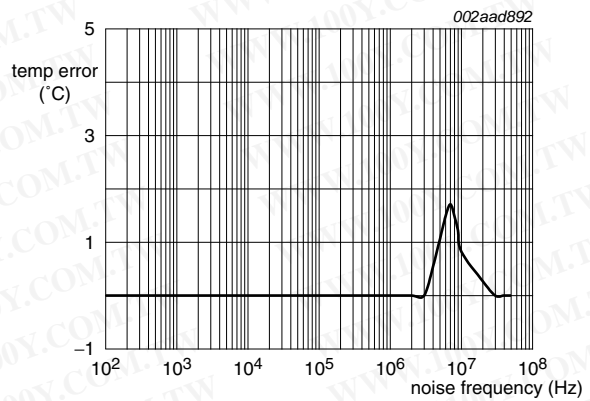

V_{DD} = 3.3 V + 150 mV (p-p); 0.1 μF AC coupling capacitor; no decoupling capacitor; T_{amb} = 25 °C.

Fig 37. Temperature error versus power supply noise frequency

勝特力材料 886-3-5753170
 勝特力电子(上海) 86-21-34970699
 勝特力电子(深圳) 86-755-83298787
[Http://www.100y.com.tw](http://www.100y.com.tw)

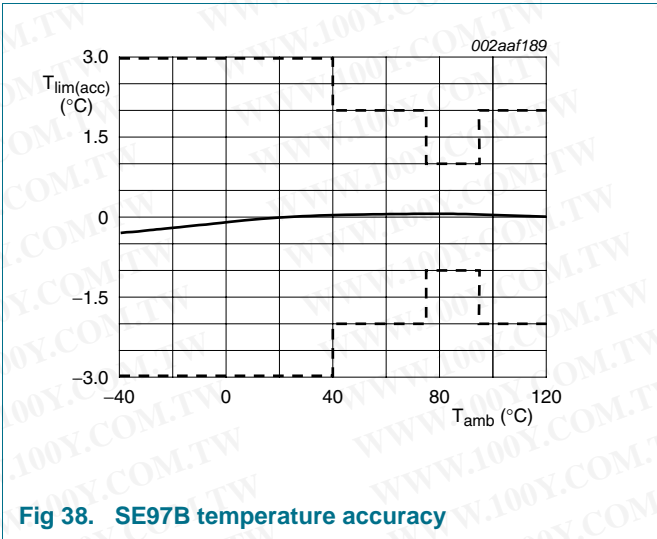

Fig 38. SE97B temperature accuracy

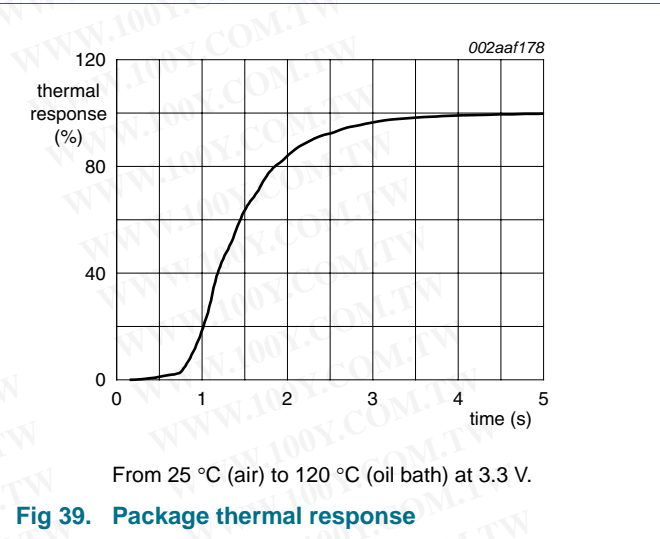

Fig 39. Package thermal response

勝特力材料 886-3-5753170
 勝特力电子(上海) 86-21-34970699
 勝特力电子(深圳) 86-755-83298787
[Http://www.100y.com.tw](http://www.100y.com.tw)

Table 32. SMBus AC characteristics

$V_{DD} = 3.0\text{ V to }3.6\text{ V}$; $T_{amb} = -40\text{ }^{\circ}\text{C to }+125\text{ }^{\circ}\text{C}$; unless otherwise specified. These specifications are guaranteed by design. The AC specifications fully meet or exceed SMBus 2.0 specifications, but allow the bus to interface with the I²C-bus from DC to 400 kHz.

Symbol	Parameter	Conditions	Standard mode		Fast mode		Unit
			Min	Max	Min	Max	
f _{SCL}	SCL clock frequency		10 ^[1]	100	10 ^[1]	400	kHz
t _{HIGH}	HIGH period of the SCL clock	70 % to 70 %	4000	-	600	-	ns
t _{LOW}	LOW period of the SCL clock	30 % to 30 %	4700	-	1300	-	ns
t _{to(SMBus)}	SMBus time-out time	LOW period to reset SMBus	25	35	25	35	ms
t _r	rise time of both SDA and SCL signals		-	1000	20	300	ns
t _f	fall time of both SDA and SCL signals		-	300	-	300	ns
t _{SU,DAT}	data set-up time		250	-	100	-	ns
t _{h(i)(D)}	data input hold time		^{[2][3]} 0	-	0	-	ns
t _{HD,DAT}	data hold time		^[4] 200	3450	200	900	ns
t _{SU,STA}	set-up time for a repeated START condition		^[5] 4700	-	600	-	ns
t _{HD,STA}	hold time (repeated) START condition	30 % of SDA to 70 % of SCL	^[6] 4000	-	600	-	ns
t _{SU,STO}	set-up time for STOP condition		4000	-	600	-	ns
t _{BUF}	bus free time between a STOP and START condition		^[2] 4700	-	1300	-	ns
t _{SP}	pulse width of spikes that must be suppressed by the input filter		-	50	-	50	ns
t _{VD,DAT}	data valid time	from clock	200	-	200	-	ns
t _{f(o)}	output fall time		-	-	-	250	ns
t _{POR}	power-on reset pulse time	power supply falling	0.5	-	0.5	-	μs
EEPROM power-up timing^[7]							
t _{pu(R)}	read power-up time		^[8] -	1	-	1	ms
t _{pu(W)}	write power-up time		^[8] -	1	-	1	ms
Write cycle limits							
T _{cy(W)}	write cycle time		^[9] -	10	-	10	ms

- [1] Minimum clock frequency is 0 kHz if SMBus Timeout is disabled.
- [2] Delay from SDA STOP to SDA START.
- [3] A device must internally provide a hold time of at least 200 ns for SDA signal (referenced to the V_{IH(min)} of the SCL signal) to bridge the undefined region of the falling edge of SCL.
- [4] Delay from SCL HIGH-to-LOW transition to SDA edges.
- [5] Delay from SCL LOW-to-HIGH transition to restart SDA.
- [6] Delay from SDA START to first SCL HIGH-to-LOW transition.
- [7] These parameters tested initially and after a design or process change that affects the parameter.
- [8] t_{pu(R)} and t_{pu(W)} are the delays required from the time V_{DD} is stable until the specified operation can be initiated.

[9] The write cycle time is the time elapsed between the STOP command (following the write instruction) and the completion of the internal write cycle. During the internal write cycle, SDA is released by the slave and the device does not acknowledge external commands.

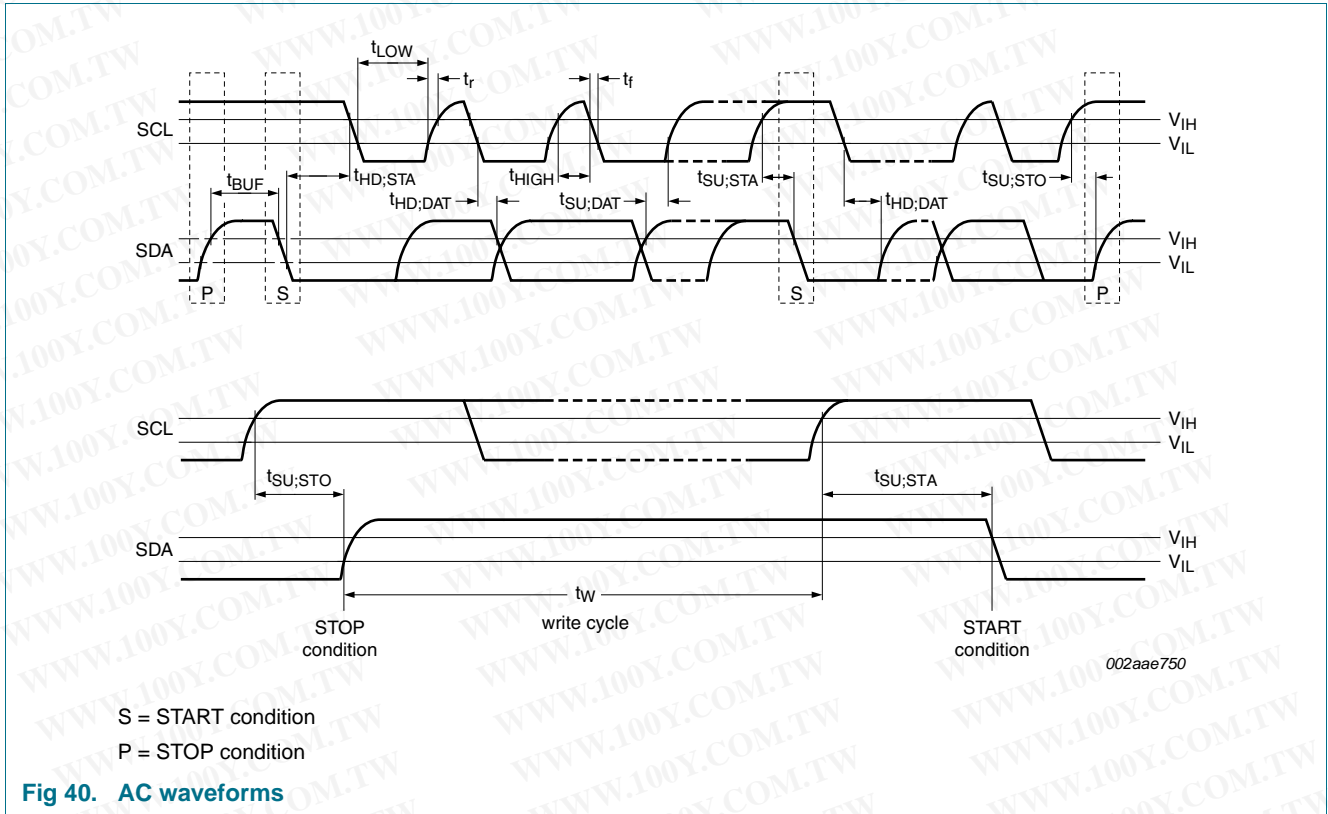

勝特力材料 886-3-5753170
 勝特力电子(上海) 86-21-34970699
 勝特力电子(深圳) 86-755-83298787
[Http://www.100y.com.tw](http://www.100y.com.tw)

12. Package outline

HWSON8: plastic thermal enhanced very very thin small outline package; no leads;
 8 terminals; body 2 x 3 x 0.8 mm

SOT1069-2

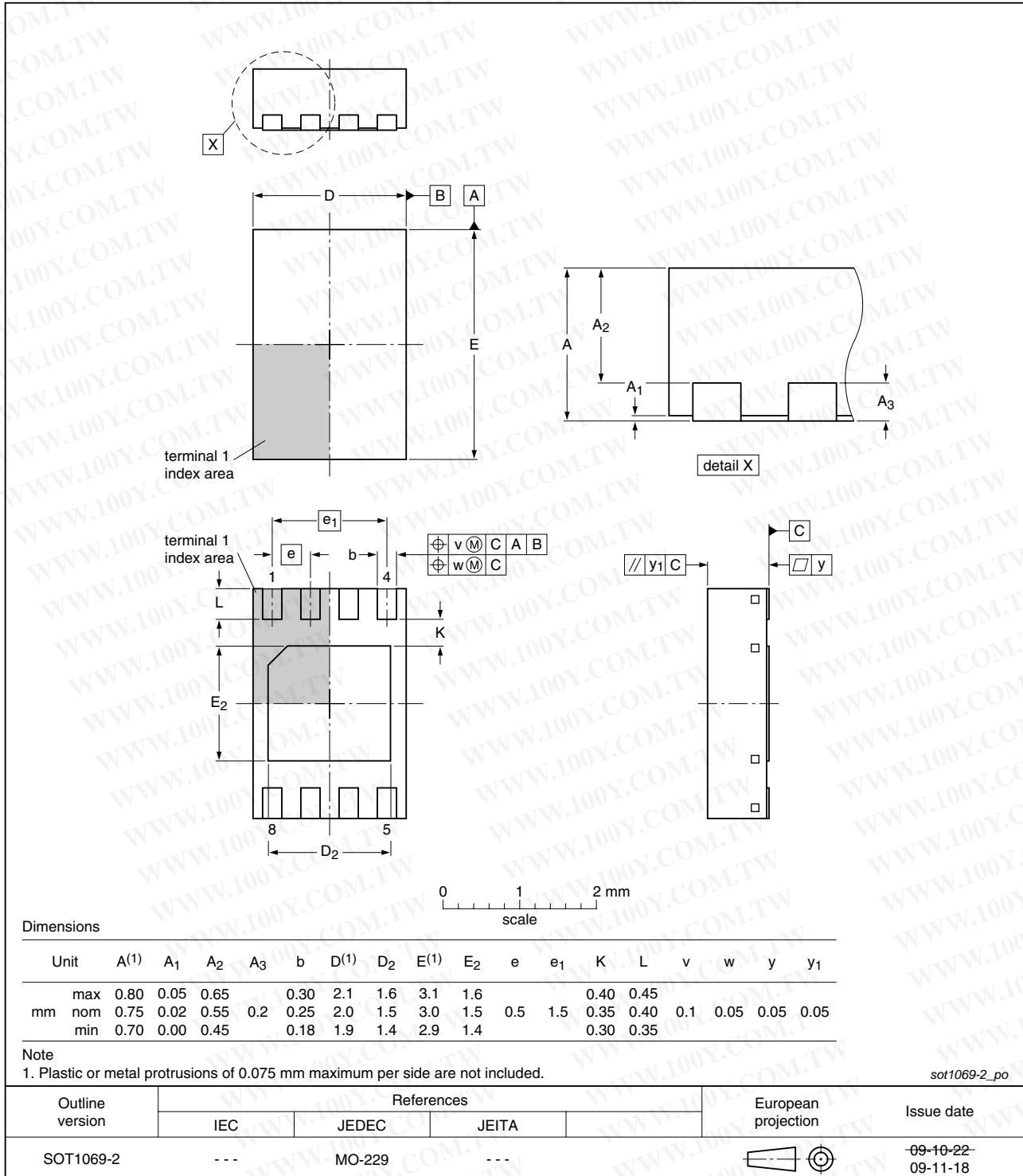

Fig 41. Package outline SOT1069-2 (HWSON8)

13. Soldering of SMD packages

This text provides a very brief insight into a complex technology. A more in-depth account of soldering ICs can be found in Application Note AN10365 "Surface mount reflow soldering description".

13.1 Introduction to soldering

Soldering is one of the most common methods through which packages are attached to Printed Circuit Boards (PCBs), to form electrical circuits. The soldered joint provides both the mechanical and the electrical connection. There is no single soldering method that is ideal for all IC packages. Wave soldering is often preferred when through-hole and Surface Mount Devices (SMDs) are mixed on one printed wiring board; however, it is not suitable for fine pitch SMDs. Reflow soldering is ideal for the small pitches and high densities that come with increased miniaturization.

13.2 Wave and reflow soldering

Wave soldering is a joining technology in which the joints are made by solder coming from a standing wave of liquid solder. The wave soldering process is suitable for the following:

- Through-hole components
- Leaded or leadless SMDs, which are glued to the surface of the printed circuit board

Not all SMDs can be wave soldered. Packages with solder balls, and some leadless packages which have solder lands underneath the body, cannot be wave soldered. Also, leaded SMDs with leads having a pitch smaller than ~0.6 mm cannot be wave soldered, due to an increased probability of bridging.

The reflow soldering process involves applying solder paste to a board, followed by component placement and exposure to a temperature profile. Leaded packages, packages with solder balls, and leadless packages are all reflow solderable.

Key characteristics in both wave and reflow soldering are:

- Board specifications, including the board finish, solder masks and vias
- Package footprints, including solder thieves and orientation
- The moisture sensitivity level of the packages
- Package placement
- Inspection and repair
- Lead-free soldering versus SnPb soldering

13.3 Wave soldering

Key characteristics in wave soldering are:

- Process issues, such as application of adhesive and flux, clinching of leads, board transport, the solder wave parameters, and the time during which components are exposed to the wave
- Solder bath specifications, including temperature and impurities

13.4 Reflow soldering

Key characteristics in reflow soldering are:

- Lead-free versus SnPb soldering; note that a lead-free reflow process usually leads to higher minimum peak temperatures (see [Figure 42](#)) than a SnPb process, thus reducing the process window
- Solder paste printing issues including smearing, release, and adjusting the process window for a mix of large and small components on one board
- Reflow temperature profile; this profile includes preheat, reflow (in which the board is heated to the peak temperature) and cooling down. It is imperative that the peak temperature is high enough for the solder to make reliable solder joints (a solder paste characteristic). In addition, the peak temperature must be low enough that the packages and/or boards are not damaged. The peak temperature of the package depends on package thickness and volume and is classified in accordance with [Table 33](#) and [34](#)

Table 33. SnPb eutectic process (from J-STD-020C)

Package thickness (mm)	Package reflow temperature (°C)	
	Volume (mm ³)	
	< 350	≥ 350
< 2.5	235	220
≥ 2.5	220	220

Table 34. Lead-free process (from J-STD-020C)

Package thickness (mm)	Package reflow temperature (°C)		
	Volume (mm ³)		
	< 350	350 to 2000	> 2000
< 1.6	260	260	260
1.6 to 2.5	260	250	245
> 2.5	250	245	245

Moisture sensitivity precautions, as indicated on the packing, must be respected at all times.

Studies have shown that small packages reach higher temperatures during reflow soldering, see [Figure 42](#).

勝特力材料 886-3-5753170
勝特力电子(上海) 86-21-34970699
勝特力电子(深圳) 86-755-83298787
[Http://www.100y.com.tw](http://www.100y.com.tw)

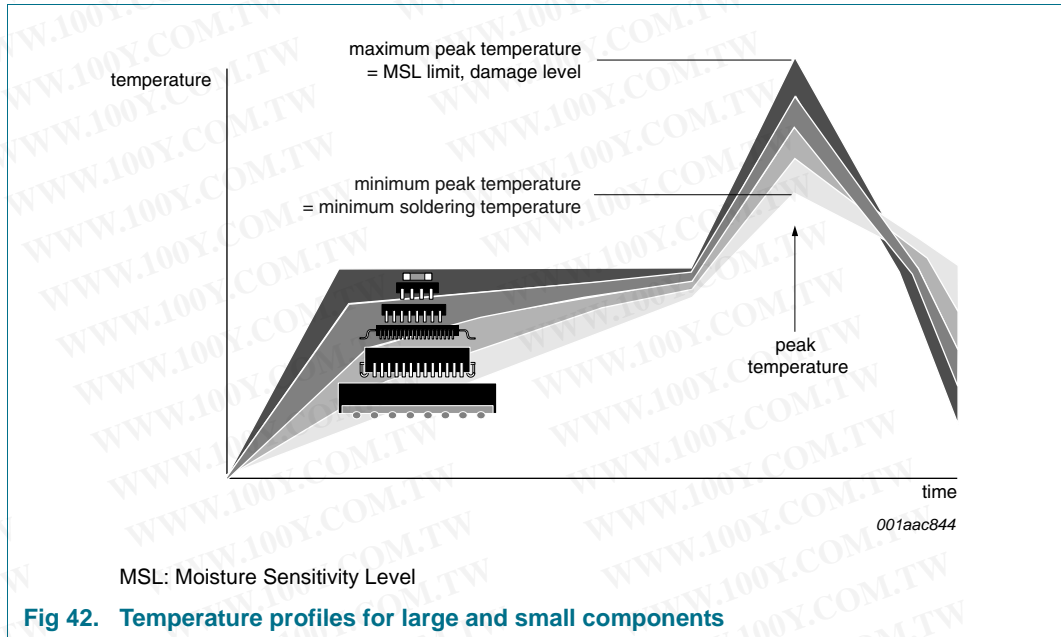

Fig 42. Temperature profiles for large and small components
 For further information on temperature profiles, refer to Application Note AN10365 “Surface mount reflow soldering description”.

14. Abbreviations

Table 35. Abbreviations

Acronym	Description
ADC	A-to-D Converter
ARA	Alert Response Address
CDM	Charged Device Model
CPU	Central Processing Unit
DDR	Double Data Rate
DIMM	Dual In-line Memory Module
DRAM	Dynamic Random Access Memory
EEPROM	Electrically Erasable Programmable Read-Only Memory
ESD	ElectroStatic Discharge
HBM	Human Body Model
I ² C-bus	Inter-Integrated Circuit bus
LSB	Least Significant Bit
MM	Machine Model
MSB	Most Significant Bit
PC	Personal Computer
PCB	Printed-Circuit Board
POR	Power-On Reset

勝特力材料 886-3-5753170
 勝特力电子(上海) 86-21-34970699
 勝特力电子(深圳) 86-755-83298787
[Http://www.100y.com.tw](http://www.100y.com.tw)

Table 35. Abbreviations ...continued

Acronym	Description
SMBus	System Management Bus
SO-DIMM	Small Outline Dual In-line Memory Module
SPD	Serial Presence Detect

15. Revision history

Table 36. Revision history

Document ID	Release date	Data sheet status	Change notice	Supersedes
SE97B_1	20100127	Product data sheet	-	-

勝特力材料 886-3-5753170
 勝特力电子(上海) 86-21-34970699
 勝特力电子(深圳) 86-755-83298787
[Http://www.100y.com.tw](http://www.100y.com.tw)

16. Legal information

16.1 Data sheet status

Document status ^{[1][2]}	Product status ^[3]	Definition
Objective [short] data sheet	Development	This document contains data from the objective specification for product development.
Preliminary [short] data sheet	Qualification	This document contains data from the preliminary specification.
Product [short] data sheet	Production	This document contains the product specification.

[1] Please consult the most recently issued document before initiating or completing a design.

[2] The term 'short data sheet' is explained in section "Definitions".

[3] The product status of device(s) described in this document may have changed since this document was published and may differ in case of multiple devices. The latest product status information is available on the Internet at URL <http://www.nxp.com>.

16.2 Definitions

Draft — The document is a draft version only. The content is still under internal review and subject to formal approval, which may result in modifications or additions. NXP Semiconductors does not give any representations or warranties as to the accuracy or completeness of information included herein and shall have no liability for the consequences of use of such information.

Short data sheet — A short data sheet is an extract from a full data sheet with the same product type number(s) and title. A short data sheet is intended for quick reference only and should not be relied upon to contain detailed and full information. For detailed and full information see the relevant full data sheet, which is available on request via the local NXP Semiconductors sales office. In case of any inconsistency or conflict with the short data sheet, the full data sheet shall prevail.

16.3 Disclaimers

General — Information in this document is believed to be accurate and reliable. However, NXP Semiconductors does not give any representations or warranties, expressed or implied, as to the accuracy or completeness of such information and shall have no liability for the consequences of use of such information.

Right to make changes — NXP Semiconductors reserves the right to make changes to information published in this document, including without limitation specifications and product descriptions, at any time and without notice. This document supersedes and replaces all information supplied prior to the publication hereof.

Suitability for use — NXP Semiconductors products are not designed, authorized or warranted to be suitable for use in medical, military, aircraft, space or life support equipment, nor in applications where failure or malfunction of an NXP Semiconductors product can reasonably be expected to result in personal injury, death or severe property or environmental

damage. NXP Semiconductors accepts no liability for inclusion and/or use of NXP Semiconductors products in such equipment or applications and therefore such inclusion and/or use is at the customer's own risk.

Applications — Applications that are described herein for any of these products are for illustrative purposes only. NXP Semiconductors makes no representation or warranty that such applications will be suitable for the specified use without further testing or modification.

Limiting values — Stress above one or more limiting values (as defined in the Absolute Maximum Ratings System of IEC 60134) may cause permanent damage to the device. Limiting values are stress ratings only and operation of the device at these or any other conditions above those given in the Characteristics sections of this document is not implied. Exposure to limiting values for extended periods may affect device reliability.

Terms and conditions of sale — NXP Semiconductors products are sold subject to the general terms and conditions of commercial sale, as published at <http://www.nxp.com/profile/terms>, including those pertaining to warranty, intellectual property rights infringement and limitation of liability, unless explicitly otherwise agreed to in writing by NXP Semiconductors. In case of any inconsistency or conflict between information in this document and such terms and conditions, the latter will prevail.

No offer to sell or license — Nothing in this document may be interpreted or construed as an offer to sell products that is open for acceptance or the grant, conveyance or implication of any license under any copyrights, patents or other industrial or intellectual property rights.

Export control — This document as well as the item(s) described herein may be subject to export control regulations. Export might require a prior authorization from national authorities.

16.4 Trademarks

Notice: All referenced brands, product names, service names and trademarks are the property of their respective owners.

I²C-bus — logo is a trademark of NXP B.V.

17. Contact information

For more information, please visit: <http://www.nxp.com>

For sales office addresses, please send an email to: salesaddresses@nxp.com

勝特力材料 886-3-5753170
 勝特力电子(上海) 86-21-34970699
 勝特力电子(深圳) 86-755-83298787
[Http://www.100y.com.tw](http://www.100y.com.tw)

18. Contents

1	General description	1	7.10.3	Read operations	20
2	Features	2	7.10.3.1	Current address read	20
2.1	General features	2	7.10.3.2	Selective read	20
2.2	Temperature sensor features	2	7.10.3.3	Sequential read	21
2.3	Serial EEPROM features	3	8	Register descriptions	22
3	Applications	3	8.1	Register overview	22
4	Ordering information	3	8.2	CAP — Capability register (00h, 16-bit read-only)	23
5	Block diagram	4	8.3	CONFIG — Configuration register (01h, 16-bit read/write)	24
6	Pinning information	5	8.4	Temperature format	28
6.1	Pinning	5	8.5	Temperature Trip Point registers	29
6.2	Pin description	5	8.5.1	UPPER — Upper Boundary Alarm Trip register (02h, 16-bit read/write)	29
7	Functional description	6	8.5.2	LOWER — Lower Boundary Alarm Trip register (03h, 16-bit read/write)	30
7.1	Serial bus interface	6	8.5.3	CRITICAL — Critical Alarm Trip register (04h, 16-bit read/write)	30
7.2	Slave address	6	8.6	TEMP — Temperature register (05h, 16-bit read-only)	31
7.3	EVENT output condition	7	8.7	MANID — Manufacturer's ID register (06h, 16-bit read-only)	32
7.3.1	EVENT pin output voltage levels and resistor sizing	7	8.8	DEVICEID — Device ID register (07h, 16-bit read-only)	32
7.3.2	EVENT thresholds	9	8.9	SMBUS — SMBus register (22h, 8-bit read/write)	33
7.3.2.1	Alarm window	9	9	Application design-in information	35
7.3.2.2	Critical trip	9	9.1	SE97B in memory module application	36
7.3.3	EVENT operation modes	10	9.2	Layout consideration	36
7.3.3.1	Comparator mode	10	9.3	Thermal considerations	36
7.3.3.2	Interrupt mode	10	9.4	Hot plugging	37
7.3.3.3	Switching between Comparator mode and Interrupt mode	10	10	Limiting values	38
7.4	Conversion rate	11	11	Characteristics	38
7.4.1	What temperature is read when conversion is in progress	11	12	Package outline	46
7.5	Power-up default condition	11	13	Soldering of SMD packages	47
7.6	Device initialization	11	13.1	Introduction to soldering	47
7.7	SMBus TIMEOUT	12	13.2	Wave and reflow soldering	47
7.8	SMBus Alert Response Address (ARA)	12	13.3	Wave soldering	47
7.9	SMBus/I ² C-bus interface	13	13.4	Reflow soldering	48
7.10	EEPROM operation	15	14	Abbreviations	49
7.10.1	Write operations	16	15	Revision history	50
7.10.1.1	Byte Write	16	16	Legal information	51
7.10.1.2	Page Write	16	16.1	Data sheet status	51
7.10.1.3	Acknowledge polling	17	16.2	Definitions	51
7.10.2	Memory Protection	17	16.3	Disclaimers	51
7.10.2.1	Permanent Write Protection (PWP)	18	16.4	Trademarks	51
7.10.2.2	Reversible Write Protection (RWP) and Clear Reversible Write Protection (CRWP)	19			
7.10.2.3	Read Permanent Write Protection (RPWP), Read Reversible Write Protection (RRWP), and Read Clear Reversible Write Protection (RCRWP)	19			

continued >>

勝特力材料 886-3-5753170
 勝特力电子(上海) 86-21-34970699
 勝特力电子(深圳) 86-755-83298787
[Http://www.100y.com.tw](http://www.100y.com.tw)

17 Contact information..... 51
 18 Contents..... 52

勝特力材料 886-3-5753170
 胜特力电子(上海) 86-21-34970699
 胜特力电子(深圳) 86-755-83298787
 Http://www.100y.com.tw



Please be aware that important notices concerning this document and the product(s) described herein, have been included in section 'Legal information'.

© NXP B.V. 2010. All rights reserved.

For more information, please visit: <http://www.nxp.com>
 For sales office addresses, please send an email to: salesaddresses@nxp.com

Date of release: 27 January 2010
 Document identifier: SE97B_1