

Current Transducer HTFS 200..800-P/SP2

$I_{PN} = 200 - 400 - 800 A$

For the electronic measurement of currents : DC, AC, pulsed, mixed, with a galvanic isolation between the primary circuit (high power) and the secondary circuit (electronic circuit).



All Data are given with a $R_L = 10\text{ k}\Omega$



Electrical data

Primary nominal r.m.s. current I_{PN} (A)	Primary current measuring range I_p (A)	Type
200	± 300	HTFS 200-P/SP2
400	± 600	HTFS 400-P/SP2
800	± 1200	HTFS 800-P/SP2
V_{OUT}	Analog output voltage @ I_p $I_p = 0$	$V_{REF} \pm (1.25 \cdot I_p / I_{PN})$ V $V_{REF} \pm 0.025$ V
V_{REF}	Internal Reference ¹⁾ - Output voltage	$1/2 V_C \pm 0.025$ V
	V_{REF} Output impedance	typ. 200 Ω
	V_{REF} Load impedance	≥ 200 k Ω
R_L	Output load resistance	≥ 2 k Ω
R_{OUT}	Output impedance	< 10 Ω
C_L	Max. output capacitive load	< 1 μ F
V_C	Supply voltage ($\pm 5\%$)	5 V
I_C	Current consumption @ $V_C = 5$ V	22 mA

Features

- Hall effect measuring principle
- Galvanic isolation between primary and secondary circuit
- Low power consumption
- Single power supply +5V
- Ratiometric offset
- $T_A = -40..+105\text{ }^\circ\text{C}$
- PCB fixation by 4 $\varnothing 1$ pins

Advantages

- Small size and space saving
- Only one design for wide current ratings range
- High immunity to external interference.
- V_{REF} IN/OUT

Accuracy - Dynamic performance data

X	Accuracy ²⁾ @ $I_{PN}, T_A = 25^\circ\text{C}$	$\leq \pm 1$	% of I_{PN}
e_L	Linearity $0 \dots 1.5 \times I_{PN}$	$\leq \pm 0.5$	% of I_{PN}
TCV_{OUT}	Thermal drift of V_{OUT} @ $I_p = 0$	$\leq \pm 0.3$	mV/K
TCV_{REF}	Thermal drift of V_{REF}	$\leq \pm 0.01$	%/K
TCV_{OUT}/V_{REF}	Thermal drift of V_{OUT}/V_{REF} @ $I_p = 0$	$\leq \pm 0.2$	mV/K
TCE_G	Thermal drift of the gain	$\leq \pm 0.05\%$	of reading/K
V_{OM}	Residual voltage @ $I_p = 0$, after an overload of $3 \times I_{PNDC}$	$< \pm 0.5$	% of I_{PN}
t_{ra}	Reaction time @ 10 % of I_{PN}	< 3	μ s
t_r	Response time @ 90 % of I_{PN}	< 7	μ s
di/dt	di/dt accurately followed	> 100	A/ μ s
	Output noise (DC .. 10 kHz)	< 15	mVpp
	(DC .. 1 MHz)	< 40	mVpp
f	Frequency bandwidth (-3 dB) ³⁾	DC .. 20	kHz

Applications

- Forklift drives
- AC variable speed drives
- Static converters for DC motor drives
- Battery supplied applications
- Uninterruptible Power Supplies (UPS)
- Switched Mode Power Supplies (SMPS)
- Power supplies for welding applications.

General data

T_A	Ambient operating temperature	- 40 .. + 105	$^\circ\text{C}$
T_S	Ambient storage temperature	- 40 .. + 105	$^\circ\text{C}$
dCp	Creepage distance	> 4	mm
dCI	Clearance distance	> 4	mm
CTI	Comparative tracking index (Group IIIa)	220	V
	UL94 classification	V0	
m	Mass	60	g
	Standards	EN50178 (97-10-01)	

勝特力材料 886-3-5753170
 勝特力电子(上海) 86-21-34970699
 勝特力电子(深圳) 86-755-83298787
[Http://www.100y.com.tw](http://www.100y.com.tw)

041222/2

Current Transducer HTFS 200..800-P/SP2

Insulation category

V_b	Nominal Voltage with IEC 61010-1 standards and following conditions	150	V r.m.s.
	<ul style="list-style-type: none"> - Single insulation - Over voltage category III - Pollution degree 2 - Heterogeneous field 		
V_b	Nominal Voltage with EN 50178 standards and following conditions	150	V r.m.s.
	<ul style="list-style-type: none"> - Reinforced insulation - Over voltage category III - Pollution degree 2 - Heterogeneous field 		
V_d	R.m.s. voltage for AC isolation test, 50/60 Hz, 1 mn	2.5	kV
V_e	R.m.s. voltage for partial discharge extinction @ 10pC	> 1	kV
V_w	Impulse withstand voltage 1.2/50µs	4	kV

If insulated cable is used for the primary circuit, the voltage category could be improved with the following table :

Cable insulation (primary)	Category
HAR 03	300V CAT III
HAR 05	400V CAT III
HAR 07	500V CAT III

Notes : ¹⁾ It is possible to overdrive V_{REF} with an external reference voltage between 2 - 2.8 V providing its ability to sink or source approx. 2.5 mA.

²⁾ Excluding offset.

³⁾ Small signal only to avoid excessive heatings of the magnetic core.

Safety :



Caution, risk of danger



Caution, risk of electrical shock

This transducer shall be used in accordance with manufacturer instruction. Power supply shall be a low voltage source and shall have an efficient protective system against over current. Power supply must incorporate a circuit breaker. This transducer shall be used in an electric/electronic equipment in respect of standards rules and applicable safety requirements. Primary bar and output terminals can provide hazardous voltage. This transducer is a built in device, of which conducting parts must be inaccessible by installation. Protective envelope or additional shield must be used.

HTFS 200..800-P/SP2

Dimensions (in mm)

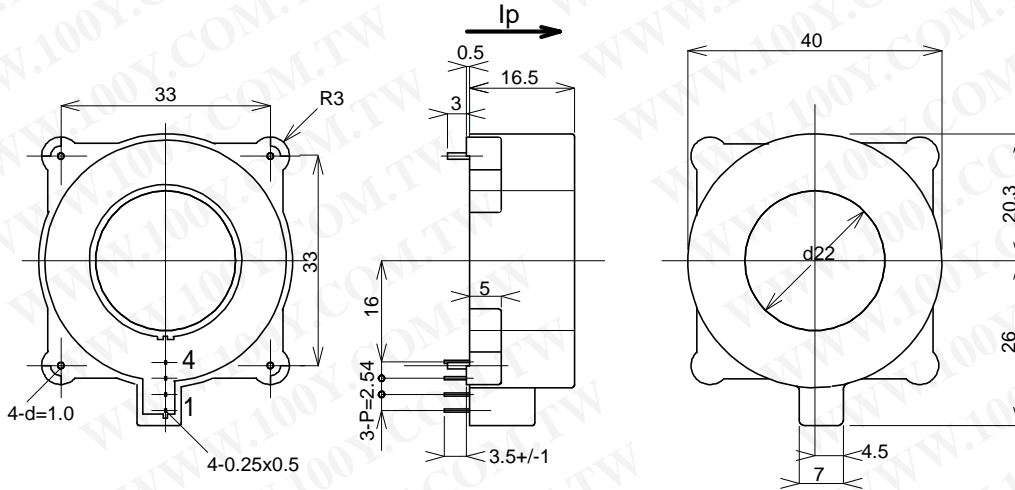

Required Connection Circuit

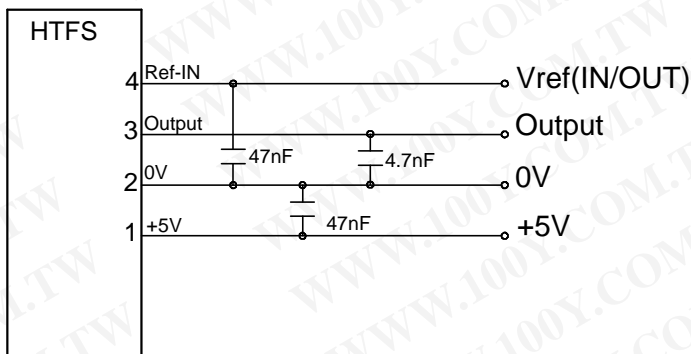

Terminal Pin

- 1...+5V
- 2...0V
- 3...Output
- 4...Vref(IN/OUT)

Operation Principle

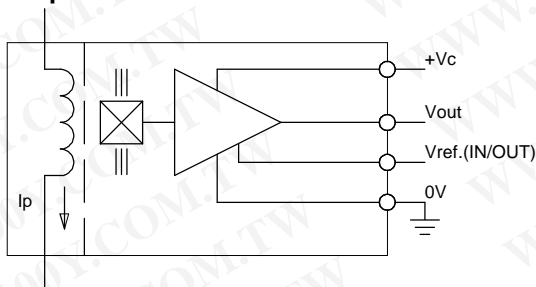

Mechanical characteristics

- General tolerance ± 0.2 mm
- Fixation 4 pins x $\varnothing 1.0$
- Recommended PCB hole $\varnothing 1.2$ mm
- Fastening & connection of secondary 4 pins 0.5 x 0.25
- Recommended PCB hole $\varnothing 0.7$ mm

Remarks

- V_{OUT} is positive when I_p flows in the direction of the arrow.
- Temperature of the primary conductor should not exceed 120°C.