

Uni- and Bipolar Hall IC Switches for Magnetic Field Applications

TLE4905L, TLE4935L, TLE4945L, TLE4945-2L

勝特力材料 886-3-5753170
勝特力电子(上海) 86-21-34970699
勝特力电子(深圳) 86-755-83298787
[Http://www.100y.com.tw](http://www.100y.com.tw)

Sensors



Never stop thinking.

Edition 2007-11

**published by Infineon Technologies AG,
Am Campeon 1-12,
81726 München, Germany**

**© Infineon Technologies AG 2007.
All Rights Reserved.**

Attention please!

The information herein is given to describe certain components and shall not be considered as a guarantee of characteristics.

Terms of delivery and rights to technical change reserved.

We hereby disclaim any and all warranties, including but not limited to warranties of non-infringement, regarding circuits, descriptions and charts stated herein.

Information

For further information on technology, delivery terms and conditions and prices please contact your nearest Infineon Technologies Office (www.infineon.com).

Warnings

Due to technical requirements components may contain dangerous substances. For information on the types in question please contact your nearest Infineon Technologies Office.

Infineon Technologies Components may only be used in life-support devices or systems with the express written approval of Infineon Technologies, if a failure of such components can reasonably be expected to cause the failure of that life-support device or system, or to affect the safety or effectiveness of that device or system. Life support devices or systems are intended to be implanted in the human body, or to support and/or maintain and sustain and/or protect human life. If they fail, it is reasonable to assume that the health of the user or other persons may be endangered.

Uni- and Bipolar Hall IC Switches for Magnetic Field Applications

**TLE4905L, TLE4935L,
TLE4945L, TLE4945-2L**

Features

- Digital output signal
- For unipolar and alternating magnetic fields
- Large temperature range
- Temperature compensated magnetic performance
- Protection against reversed polarity
- Output protection against electrical disturbances

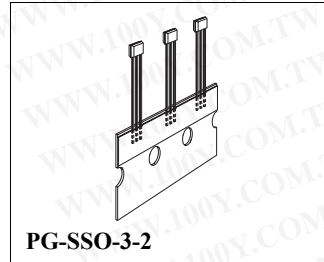

| Type | Marking | Package |
|------------|---------|------------|
| TLE4905L | 05 L | PG-SSO-3-2 |
| TLE4935L | 35 L | PG-SSO-3-2 |
| TLE4935-2L | 35 2 | PG-SSO-3-2 |
| TLE4945L | 45 L | PG-SSO-3-2 |
| TLE4945-2L | 45 2 | PG-SSO-3-2 |

TLE4905/35/45/45-2 L (Unipolar/Bipolar Magnetic Field Switches) have been designed specifically for automotive and industrial applications. Reverse polarity protection is included on-chip as is output protection against negative voltage transients.

Typical applications are position/proximity indicators, brushless DC motor commutation, rotational indexing etc.

Pin Configuration

(view on branded side of component)

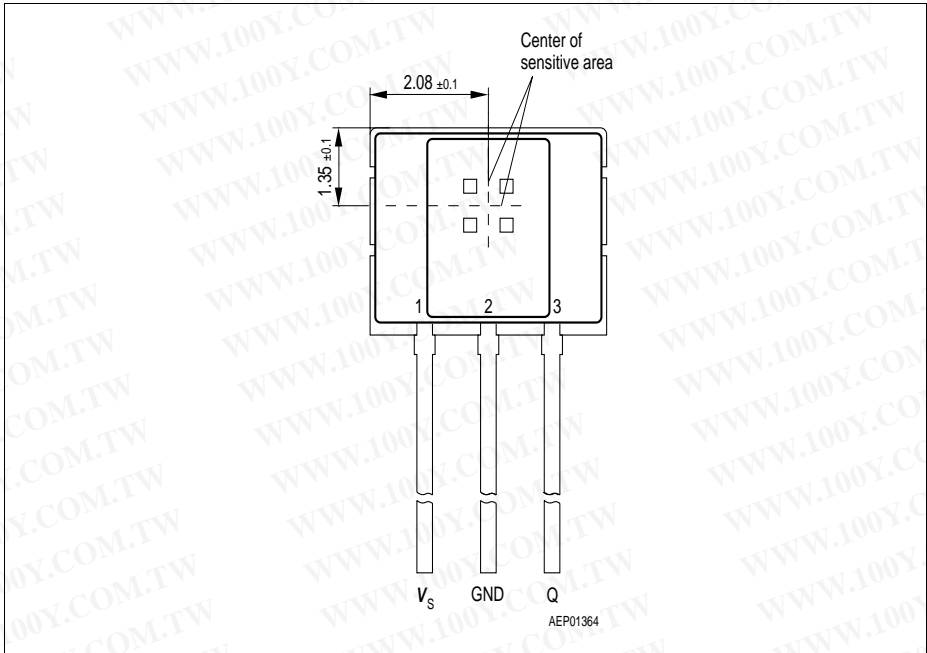

Figure 1

Pin Definitions and Functions

| Pin No. | Symbol | Function |
|---------|--------|----------------|
| 1 | V_s | Supply voltage |
| 2 | GND | Ground |
| 3 | Q | Output |

Circuit Description

The circuit includes Hall generator, amplifier and Schmitt-Trigger on one chip. The internal reference provides the supply voltage for the components. A magnetic field perpendicular to the chip surface induces a voltage at the hall probe. This voltage is amplified and switches a Schmitt-trigger with open-collector output. A protection diode against reverse power supply is integrated. The output is protected against electrical disturbances.

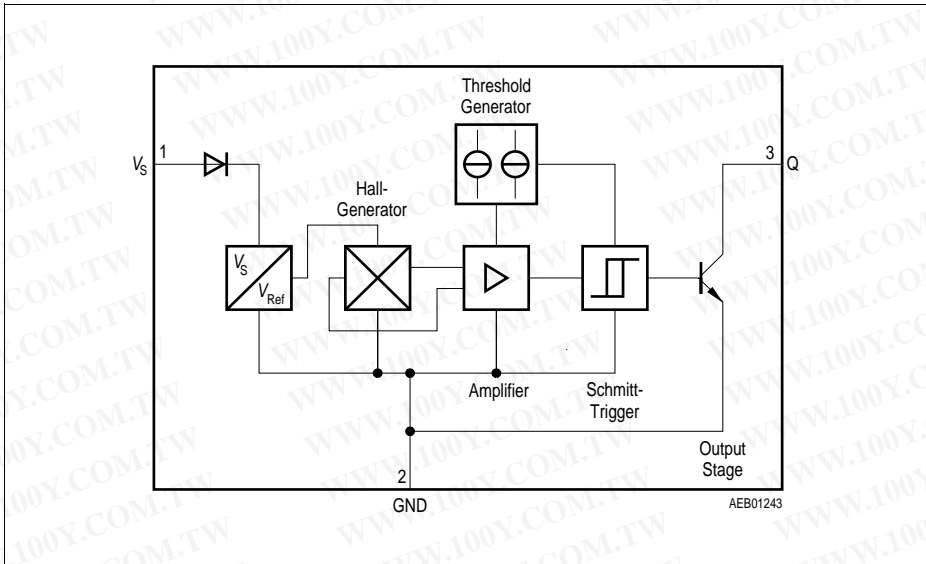

Figure 2 Block Diagram

Functional Description Unipolar Type TLE4905 (Figure 3 and 4)

When a positive magnetic field is applied in the indicated direction (**Figure 3**) and the turn-on magnetic induction B_{OP} is exceeded, the output of the Hall-effect IC will conduct (Operate Point). When the current is reduced, the output of the IC turns off (Release Point; **Figure 4**).

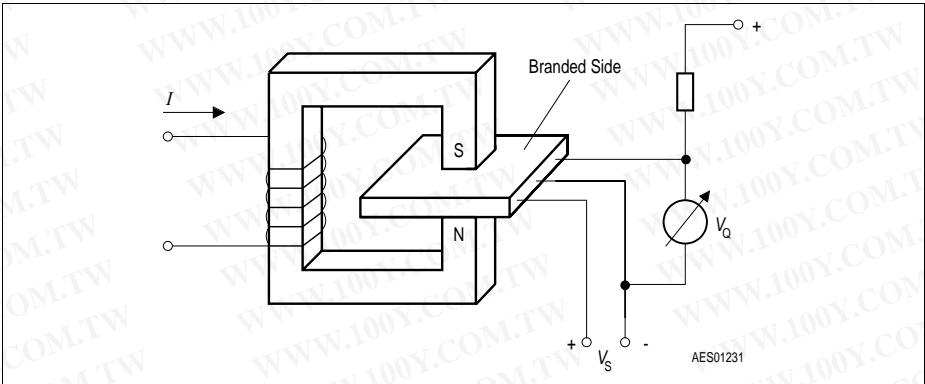

Figure 3 Sensor/Magnetic-Field Configuration

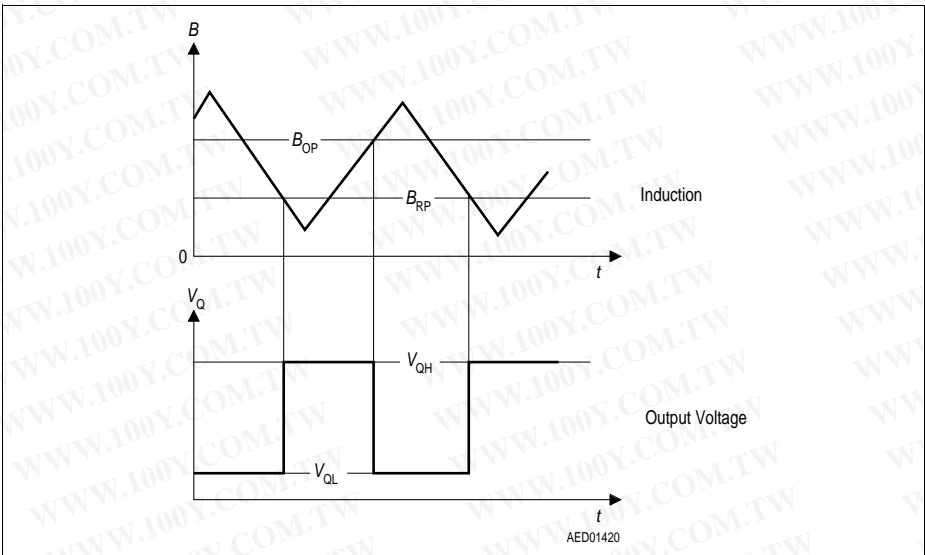

Figure 4 Switching Characteristics Unipolar Type

Functional Description Bipolar Type TLE4935/45/45-2 (Figure 5 and 6)

When a positive magnetic field is applied in the indicated direction (**Figure 5**) and the turn-on magnetic induction B_{OP} is exceeded, the output of the Hall-effect IC will conduct (Operate Point). The output state does not change unless a reverse magnetic field exceeding the turn-off magnetic induction B_{RP} is exceeded. In this case the output will turn off (Release Point; **Figure 6**).

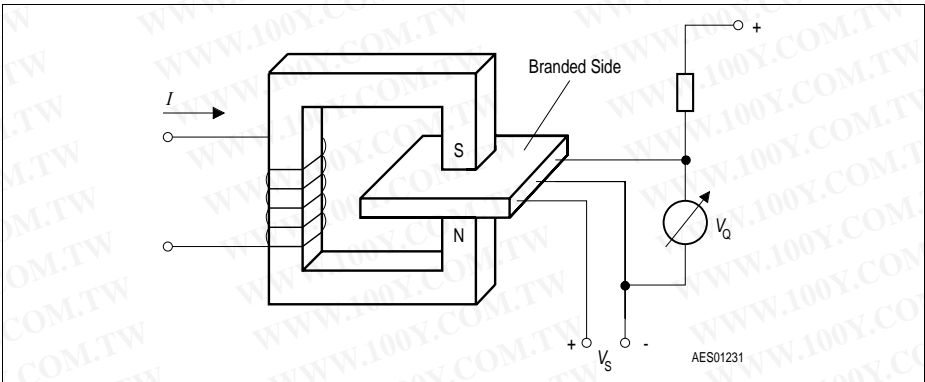

Figure 5 Sensor/Magnetic-Field Configuration

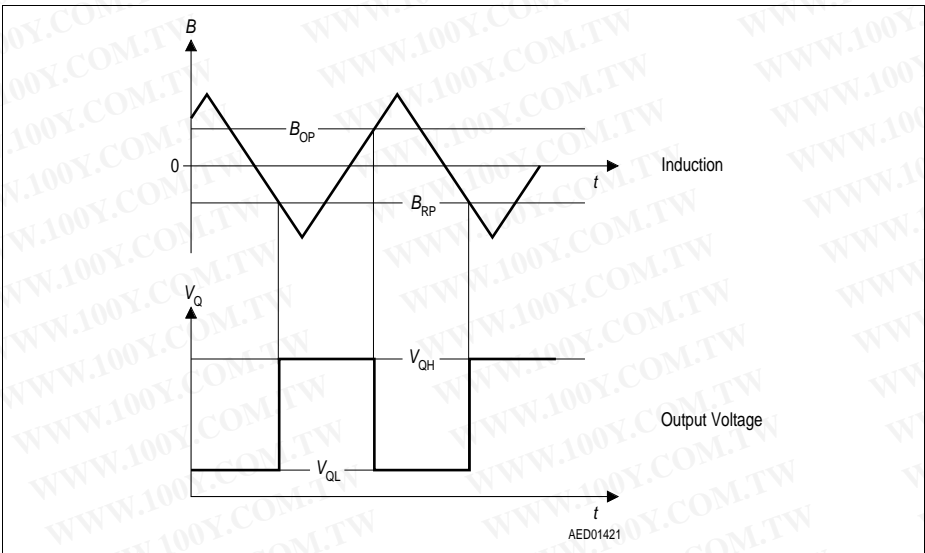

Figure 6 Switching Characteristics Bipolar Type

Absolute Maximum Ratings
 $T_j = -40$ to 150 °C

| Parameter | Symbol | Limit Values | | Unit | Remarks |
|------------------------|-------------|--------------|------|------|-------------------------|
| | | min. | max. | | |
| Supply voltage | V_S | -40 | 32 | V | - |
| Supply voltage | V_S | - | 40 | V | $t < 400$ ms; $v = 0.1$ |
| Output voltage | V_Q | - | 32 | V | - |
| Output current | I_Q | - | 100 | mA | - |
| Output reverse current | $-I_Q$ | - | 100 | mA | - |
| Junction temperature | T_j | -40 | 150 | °C | - |
| Junction temperature | T_j | - | 170 | °C | 1000 h |
| Junction temperature | T_j | - | 210 | °C | 40 h |
| Storage temperature | T_{stg} | -50 | 150 | °C | - |
| Thermal resistance | $R_{th JA}$ | - | 190 | K/W | - |

Note: Stresses above those listed here may cause permanent damage to the device. Exposure to absolute maximum rating conditions for extended periods may affect device reliability.

Operating Range

| Parameter | Symbol | Limit Values | | Unit | Remarks |
|----------------------|--------|--------------|------|------|---------|
| | | min. | max. | | |
| Supply voltage | V_S | 3.8 | 24 | V | - |
| Junction temperature | T_j | -40 | 150 | °C | - |
| | | - | 170 | | |

Note: In the operating range the functions given in the circuit description are fulfilled.

AC/DC Characteristics
 $3.8\text{ V} \leq V_S \leq 24\text{ V}; -40\text{ }^\circ\text{C} \leq T_j \leq 150\text{ }^\circ\text{C}$

| Parameter | Symbol | Limit Values | | | Unit | Test Condition | Test Circuit |
|---------------------------|--------------------|--------------|------|------|---------------|---|--------------|
| | | min. | typ. | max. | | | |
| Supply current | I_{SHigh} | – | 3 | 7 | mA | $B < B_{\text{RP}}$ | 1 |
| | I_{SLow} | – | 4 | 8 | mA | $B > B_{\text{OP}}$ | 1 |
| Output saturation voltage | V_{QSat} | – | 0.25 | 0.5 | V | $I_{\text{Q}} = 40\text{ mA}$ | 1 |
| Output leakage current | I_{QL} | – | – | 10 | μA | $V_{\text{Q}} = 24\text{ V}$ | 1 |
| Rise/fall time | t_r / t_f | – | – | 1 | μs | $R_L = 1.2\text{ k}\Omega$ $C_L \leq 33\text{ pF}$ | 1 |

Note: Typical characteristics specify mean values expected over the production spread. If not otherwise specified, typical characteristics apply at $T_j = 25\text{ }^\circ\text{C}$ and the given supply voltage.

Magnetic Characteristics
 $3.8 \text{ V} \leq V_S \leq 24 \text{ V}$

| Parameter | Symbol | Limit Values | | | | | | | | Unit |
|-----------|--------|------------------|------|-----------------------|------|------------------------|------|--------------------------|------|------|
| | | TLE4905 unipolar | | TLE4935 bipolar latch | | TLE4945 bipolar switch | | TLE4945-2 bipolar switch | | |
| | | min. | max. | min. | max. | min. | max. | min. | max. | |

Junction Temperature $T_j = -40 \text{ }^\circ\text{C}$

| | | | | | | | | | | |
|----------------------------------|--------------|-----|-----|-----|-----|-----|----|----|---|----|
| Turn-ON induction | B_{OP} | 7.5 | 19 | 10 | 20 | -6 | 10 | -3 | 6 | mT |
| Turn-OFF induction | B_{RP} | 5.5 | 17 | -20 | -10 | -10 | 6 | -6 | 3 | mT |
| Hysteresis ($B_{OP} - B_{RP}$) | ΔB_H | 2 | 6.5 | 20 | 40 | 2 | 10 | 1 | 5 | mT |

Junction Temperature $T_j = 25 \text{ }^\circ\text{C}$

| | | | | | | | | | | |
|----------------------------------|--------------|---|----|-----|-----|-----|----|----|---|----|
| Turn-ON induction | B_{OP} | 7 | 18 | 10 | 20 | -6 | 10 | -3 | 6 | mT |
| Turn-OFF induction | B_{RP} | 5 | 16 | -20 | -10 | -10 | 6 | -6 | 3 | mT |
| Hysteresis ($B_{OP} - B_{RP}$) | ΔB_H | 2 | 6 | 20 | 40 | 2 | 10 | 1 | 5 | mT |

Junction Temperature $T_j = 85 \text{ }^\circ\text{C}$

| | | | | | | | | | | |
|----------------------------------|--------------|-----|------|-----|-----|-----|----|----|---|----|
| Turn-ON induction | B_{OP} | 6.5 | 17.5 | 10 | 20 | -6 | 10 | -3 | 6 | mT |
| Turn-OFF induction | B_{RP} | 4.5 | 15 | -20 | -10 | -10 | 6 | -6 | 3 | mT |
| Hysteresis ($B_{OP} - B_{RP}$) | ΔB_H | 2 | 5.5 | 20 | 40 | 2 | 10 | 1 | 5 | mT |

Magnetic Characteristics (cont'd)
 $3.8 \text{ V} \leq V_S \leq 24 \text{ V}$

| Parameter | Symbol | Limit Values | | | | | | | | Unit |
|-----------|--------|------------------|------|-----------------------|------|------------------------|------|--------------------------|------|------|
| | | TLE4905 unipolar | | TLE4935 bipolar latch | | TLE4945 bipolar switch | | TLE4945-2 bipolar switch | | |
| | | min. | max. | min. | max. | min. | max. | min. | max. | |

Junction Temperature $T_j = 150 \text{ }^\circ\text{C}$

| | | | | | | | | | | |
|----------------------------------|--------------|---|----|-----|-----|-----|----|----|---|----|
| Turn-ON induction | B_{OP} | 6 | 17 | 10 | 20 | -6 | 10 | -3 | 6 | mT |
| Turn-OFF induction | B_{RP} | 4 | 14 | -20 | -10 | -10 | 6 | -6 | 3 | mT |
| Hysteresis ($B_{OP} - B_{RP}$) | ΔB_H | 2 | 5 | 20 | 40 | 2 | 10 | 1 | 5 | mT |

Note: The listed magnetic characteristics are ensured over the operating range of the integrated circuit. Typical characteristics specify mean values expected over the production spread. If not otherwise specified, typical characteristics apply at $T_j = 25 \text{ }^\circ\text{C}$ and the given supply voltage.

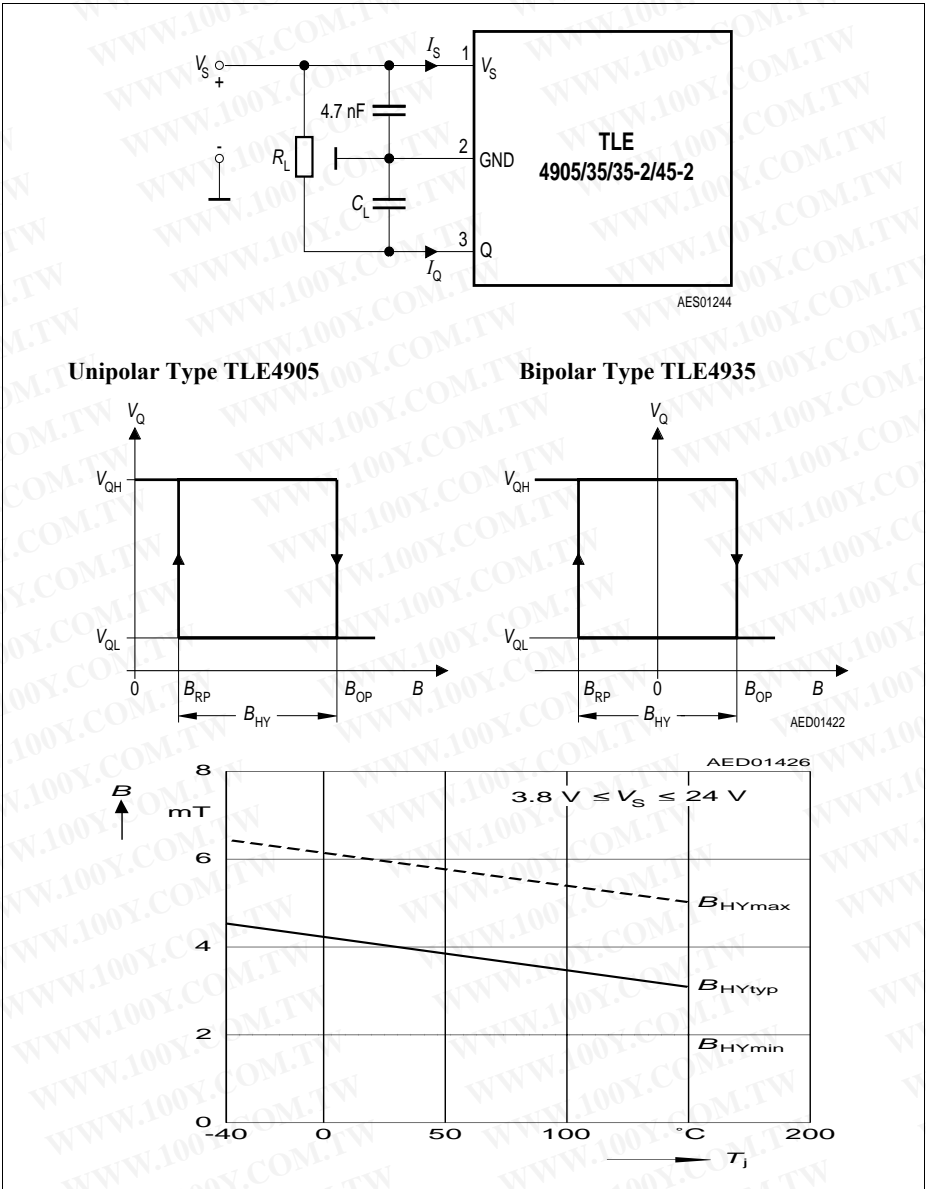

Figure 7 Test Circuit 1

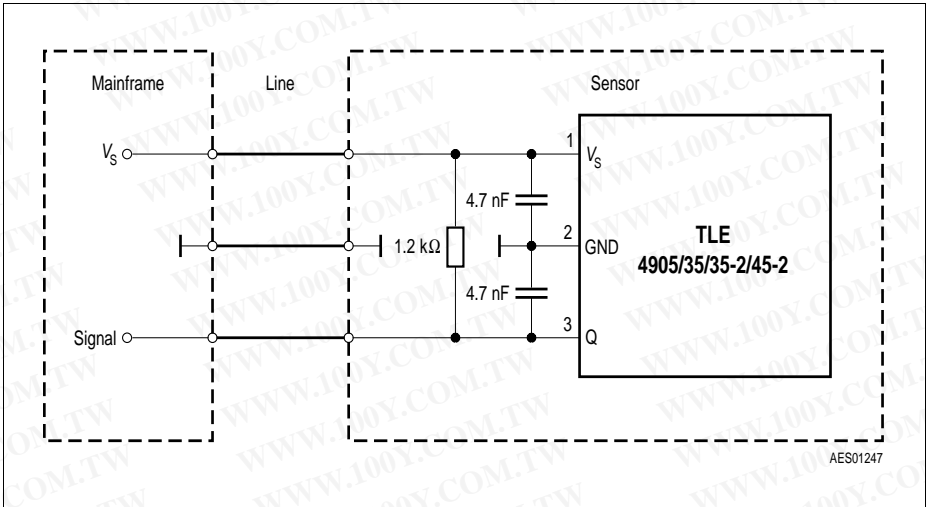
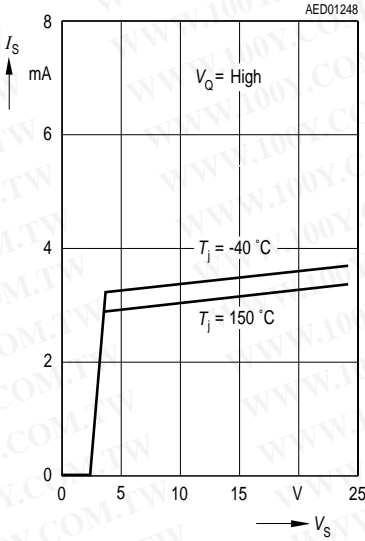

Figure 8 Application Circuit

If not otherwise specified, all curves reflect typical values at $T_j = 25^\circ\text{C}$ and $V_S = 12\text{ V}$

Quiescent Current versus Supply Voltage



Quiescent Current versus Junction Temperature

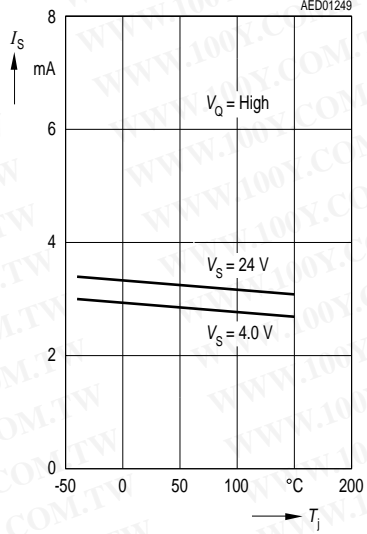

Quiescent Current Difference versus Temperature

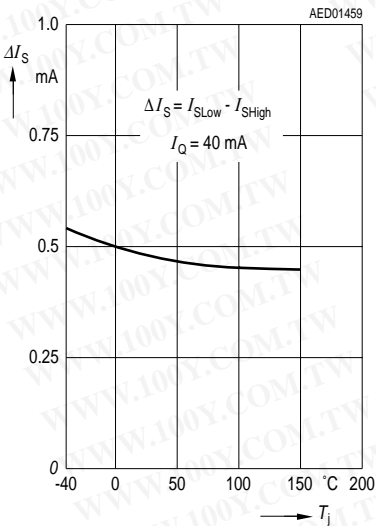

Saturation Voltage versus Output Current

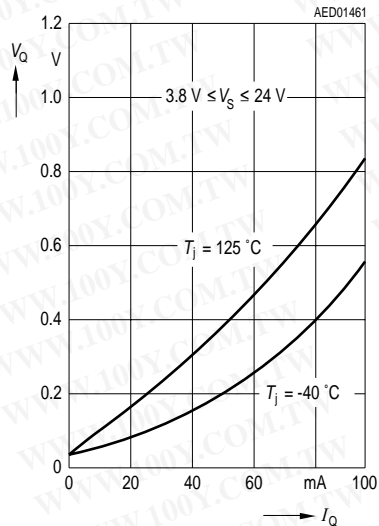

TLE4905 Operate-and Release-Point versus Junction Temperature

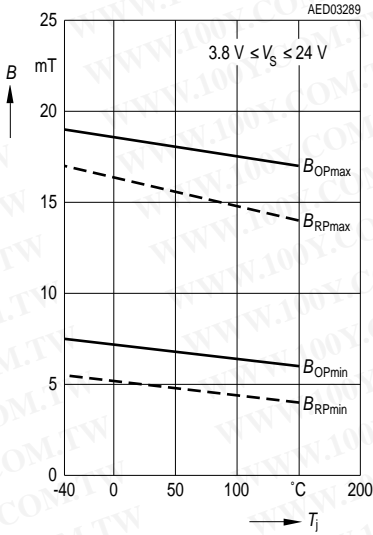

TLE4905 Hysteresis versus Junction Temperature

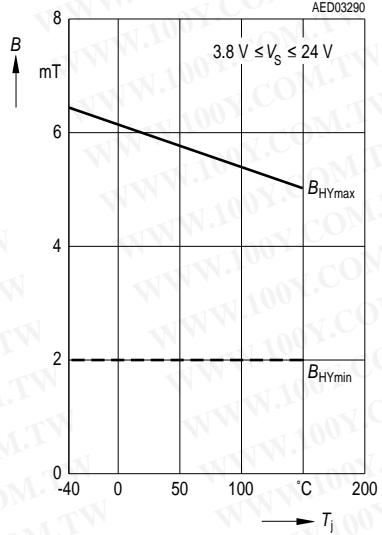

TLE4935 Operate-and Release-Point versus Junction Temperature

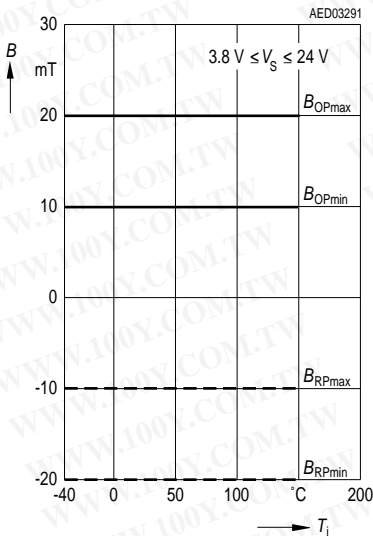

TLE4945 Operate-and Release-Point versus Junction Temperature

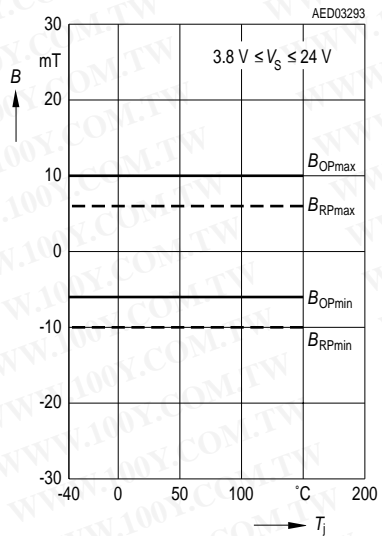

TLE4945-2 Operate-and Release-Point versus Junction Temperature

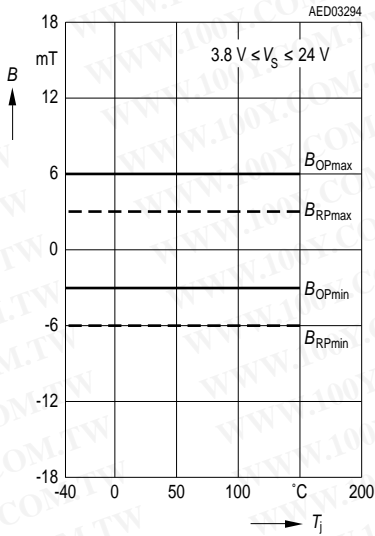

Package Outlines

PG-SSO-3-2

(Plastic Single Small Outline Package)

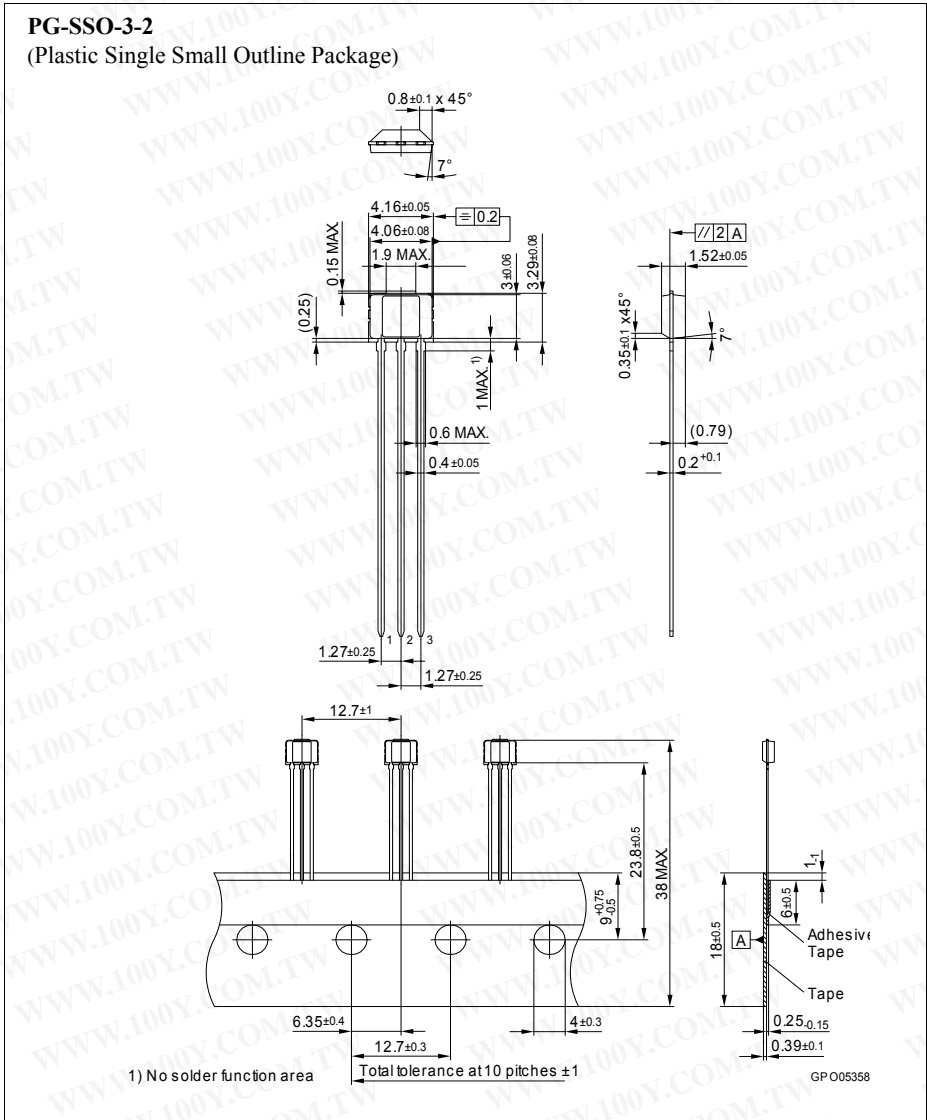

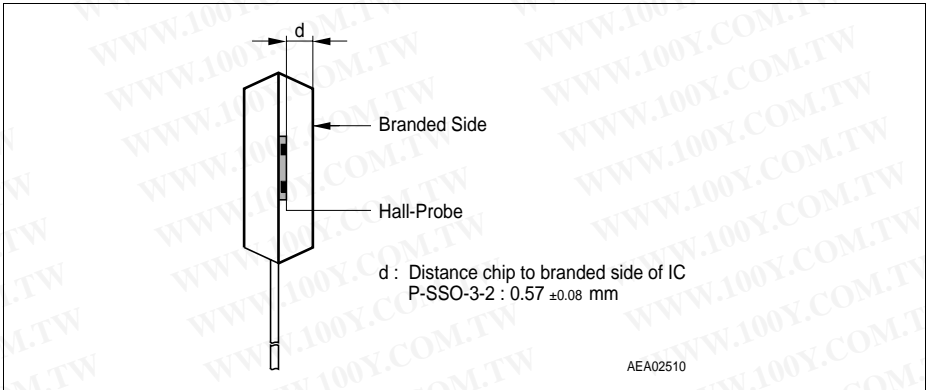

勝特力材料 886-3-5753170
勝特力电子(上海) 86-21-34970699
勝特力电子(深圳) 86-755-83298787
Http://www.100y.com.tw