

勝特力材料 886-3-5753170
 勝特力电子(上海) 86-21-34970699
 勝特力电子(深圳) 86-755-83298787
 Http://www.100y.com.tw

efector100

ifm electronic



Inductive sensors

IGS209

IGKC012-ASKG/M/US
 Inductive sensor
 Metal thread M18 x 1
 Connector
 Operation as 3-wire or 2-wire
 possible
 Increased sensing range
 Optical setting aid (2 LED)
 gold-plated contacts

Sensing range 12 mm [nf]
 non-flush mountable

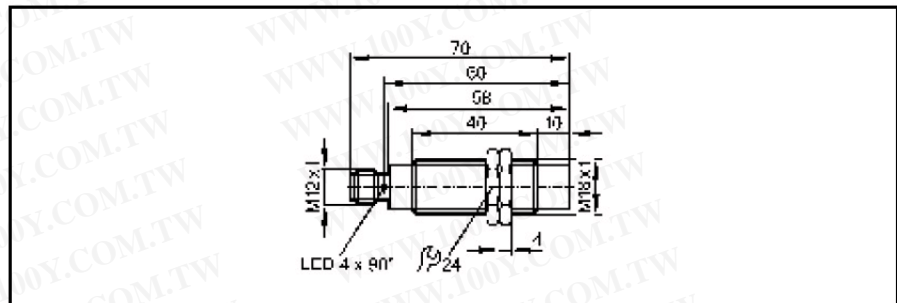

Made in Germany

Electrical design	3-wire DC PNP; 2-wire DC PNP/NPN
Output	normally open
Operating voltage [V]	10...30 DC
Current rating [mA]	100
Minimum load current [mA]	2 *)
Short-circuit protection	pulsed
Reverse polarity protection	yes
Overload protection	yes
Overload protection	yes
Voltage drop [V]	< 2.8
Leakage current [mA]	< 0.5 *)
Current consumption [mA]	< 12 (24 V)
Real sensing range [mm]	12 ± 10 %
Operating distance [mm]	0...9.7
Switch-point drift [% of Sr]	-10...10
Hysteresis [% of Sr]	3...15
Switching frequency [Hz]	300
Correction factors	mild steel = 1 / stainless steel approx. 0.7 / brass approx. 0.5 / Al approx. 0.4 / Cu approx. 0.3
Ambient temperature [°C]	-25...70
Protection	IP 67, II
EMC	EN 61000-4-2 ESD: 4 kV CD / 8 kV AD EN 61000-4-3 HF radiated: 10 V/m (80...1000 MHz) EN 61000-4-4 Burst: 2 kV EN 61000-4-6 HF conducted: 10 V (0.15...80 MHz) EN 55011: class B
Housing materials	brass white bronze coated; active face: PBT (Pocan)
Function display	
Switching status	LED yellow (4 x 90°)
Setting aid	LED red
Connection	M12 connector; gold-plated contacts
Weight [kg]	0.054
Remarks	suitable for PLC type 1 according to IEC 61131-2 *) only in 2-wire operation
Accessories (included)	2 lock nuts

Wiring

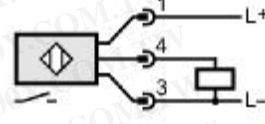
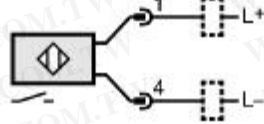

ifm electronic gmbh • Friedrichstraße 1 • 45128 Essen — We reserve the right to make technical alterations without prior notice. — GB — IGS209-00 — 18/02.2008

勝特力材料 886-3-5753170
 勝特力电子(上海) 86-21-34970699
 勝特力电子(深圳) 86-755-83298787
[Http://www.100y.com.tw](http://www.100y.com.tw)