

**NEW**

PHOTO IC

勝特力材料 886-3-5753170  
 勝特力电子(上海) 86-21-54151736  
 勝特力电子(深圳) 86-755-83298787  
[Http://www.100y.com.tw](http://www.100y.com.tw)



# Photo IC diode S9648-100

Plastic package shaped the same as metal package

The S9648-100 photo IC has spectral response close to human eye sensitivity. Two active areas are made on a single chip. Almost only the visible range can be measured by finding the difference between the two output signals in the internal current amplifier circuit. Compared to the conventional type, the S9648-100 offers lower output fluctuations for light sources producing the same illuminance at different color temperatures. The S9648-100 is encapsulated in a plastic package having the same shape as to metal packages. The shape of the S9648-100 also resembles our 5R type visible sensors (CdS photoconductive cells), so the S9648-100 can be used as a replacement for those visible sensors.

### Features

- Spectral response close to human eye sensitivity is attained without using visual-compensated filter.
- Operation just as easy to use as a photodiode
- Lower output-current fluctuations compared with phototransistors and CdS photoconductive cells.
- Excellent linearity
- Low output fluctuations for light sources producing the same illuminance at different color temperatures

### Applications

- Energy-saving sensor for TVs, etc.
- Light dimmers for liquid crystal panels
- Various types of light level measurement

#### ■ Absolute maximum ratings (Ta=25 °C)

Parameter	Symbol	Value	Unit
Maximum reverse voltage	VR Max.	-0.5 to 12	V
Photocurrent	IL	5	mA
Forward current	IF	5	mA
Power dissipation *1	P	250	mW
Operating temperature	Topr	-30 to +80	°C
Storage temperature	Tstg	-40 to +85	°C

\*1: Derate power dissipation at a rate of -3.3 mW/°C above Ta=25 °C.

#### ■ Electrical and optical characteristics (Ta=25 °C, unless otherwise noted.)

Parameter	Symbol	Condition	Min.	Typ.	Max.	Unit
Spectral response range	$\lambda$		-	300 to 820	-	nm
Peak sensitivity wavelength	$\lambda_p$		-	560	-	nm
Dark current	ID	VR=5 V	-	1.0	50	nA
Photocurrent	IL	VR=5 V, 2856 K, 100 lx	0.18	0.26	0.34	mA
Rise time *2	tr	10 to 90 %, VR=7.5 V RL=10 k $\Omega$ , $\lambda$ =560 nm	-	6.0	-	ms
Fall time *2	tf	90 to 10 %, VR=7.5 V RL=10 k $\Omega$ , $\lambda$ =560 nm	-	2.5	-	ms

\*2: Rise/fall time measurement method

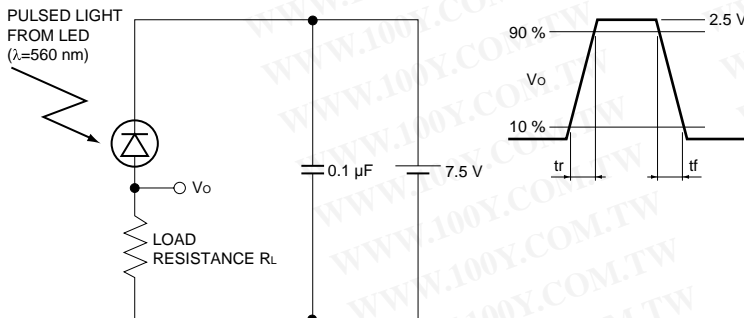

KPIC0041EA

**SOLID STATE DIVISION**

■ Spectral response

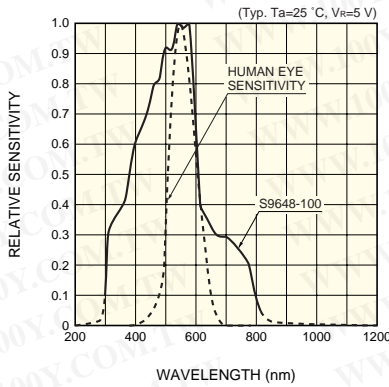

■ Linearity

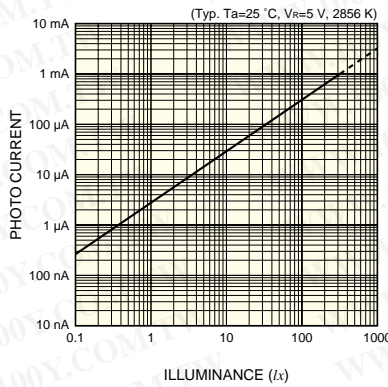

■ Rise/fall times vs. load resistance

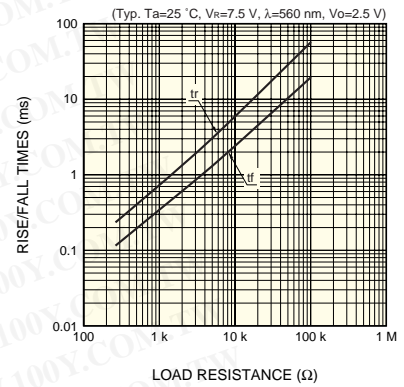

■ Operating circuit example

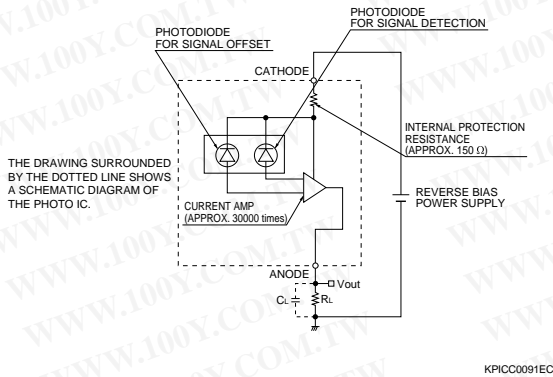

The photo IC diode must be reverse-biased so that a positive potential is applied to the cathode. To eliminate high-frequency components, we recommend placing a load capacitance  $C_L$  in parallel with load resistance  $R_L$  as a low-pass filter.

$$\text{Cut-off frequency } f_c \doteq \frac{1}{2\pi C_L R_L}$$

■ Dimensional outline (unit: mm)

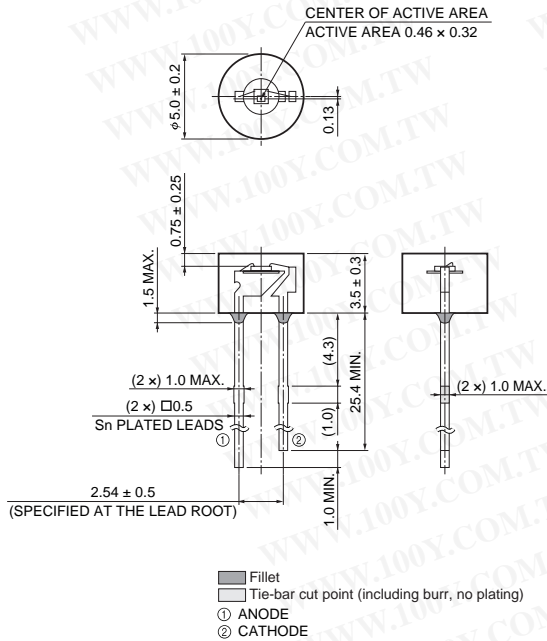

勝特力材料 886-3-5753170  
 勝特力电子(上海) 86-21-54151736  
 勝特力电子(深圳) 86-755-83298787  
[Http://www.100y.com.tw](http://www.100y.com.tw)

**HAMAMATSU**

Information furnished by HAMAMATSU is believed to be reliable. However, no responsibility is assumed for possible inaccuracies or omissions. Specifications are subject to change without notice. No patent rights are granted to any of the circuits described herein. ©2008 Hamamatsu Photonics K.K.

HAMAMATSU PHOTONICS K.K., Solid State Division

1126-1 Ichino-cho, Hamamatsu City, 435-8558 Japan, Telephone: (81) 53-434-3311, Fax: (81) 53-434-5184, www.hamamatsu.com

U.S.A.: Hamamatsu Corporation: 360 Foothill Road, P.O.Box 6910, Bridgewater, N.J. 08807-0910, U.S.A., Telephone: (1) 908-231-0960, Fax: (1) 908-231-1218

Germany: Hamamatsu Photonics Deutschland GmbH: Arzbergerstr. 10, D-82211 Herrsching am Ammersee, Germany, Telephone: (49) 08152-3750, Fax: (49) 08152-2658

France: Hamamatsu Photonics France S.A.R.L.: 19, Rue du Saule Trépu, Parc du Moulin de Massy, 91882 Massy Cedex, France, Telephone: 33-(1) 69 53 71 00, Fax: 33-(1) 69 53 71 10

United Kingdom: Hamamatsu Photonics UK Limited: 2 Howard Court, 10 Tevin Road, Welwyn Garden City, Hertfordshire AL7 1BW, United Kingdom, Telephone: (44) 1707-294888, Fax: (44) 1707-325777

North Europe: Hamamatsu Photonics Norden AB: Smidsvågen 12, SE-171 41 Solna, Sweden, Telephone: (46) 8-509-031-00, Fax: (46) 8-509-031-01

Italy: Hamamatsu Photonics Italia S.R.L.: Strada della Moia, 1/E, 20020 Arese, (Milano), Italy, Telephone: (39) 02-935-81-733, Fax: (39) 02-935-81-741